

Project Manual For:

**Napaskiak RPSU Project
On Site Construction
Project No. 24078**



**State of Alaska
Alaska Energy Authority
813 W Northern Lights Blvd, Anchorage, Alaska 99503**

Advertising Date: November 14, 2023

This page is blank intentionally.

Table of Contents

Project Manual

DIVISION 00 – BIDDING AND CONTRACT REQUIREMENTS

<u>Section No.</u>		<u>Form</u>	<u>Date</u>
<u>Invitation</u>			
00 02 00	INVITATION TO BID	25D-7	(8/01)
<u>Bid Notices</u>			
00 10 00	INFORMATION TO BIDDERS	25D-3	(7/88)
00 10 10	SUPPLEMENTARY INFORMATION TO BIDDERS		(11/92)
00 11 50A	SPECIAL NOTICE TO BIDDERS		
00 12 00	REQUIRED DOCUMENTS	25D-4	(4/12)
<u>Forms</u>			
00 12 90	FEDERAL EEO BID CONDITIONS	25A-301	(8/01)
00 31 00	PROPOSAL	25D-9A	(07/03)
00 32 00	BID SCHEDULE		
00 41 00	BID BOND	25D-14	(8/01)
00 42 00	BID MODIFICATION	25D-16	(8/01)
00 43 00	SUBCONTRACTOR LIST	25D-5	(10/12)
00 51 00	CONSTRUCTION CONTRACT	25D-10A	(8/01)
00 61 00	PERFORMANCE BOND	25D-13	(8/01)
00 62 00	PAYMENT BOND	25D-12	(8/01)
00 67 00	CONTRACTOR'S QUESTIONNAIRE	25D-8	(8/01)
<u>Contract Provisions and Specifications</u>			
00 70 00	GENERAL CONDITIONS		
00 80 00	SUPPLEMENTARY CONDITIONS		
00 90 00	FEDERAL TERMS AND CONDITIONS		

DIVISION 01 – GENERAL REQUIREMENTS

Section 01 11 13 - Summary of Work

Section 01 12 19 - Contractors Certification of Subcontracts

Section 01 12 19A - Sub Cert Form

Section 01 26 63 - Change Procedures
Section 01 26 63A - RFI Form
Section 01 26 63B - CO Request Form
Section 01 26 63C - Directive Form
Section 01 29 73 - Schedule of Values
Section 01 29 76 - Application for Payment
Section 01 31 19 - Project Meetings
Section 01 32 16 - Construction Progress Schedule
Section 01 32 26 - Construction Progress Reporting
Section 01 33 00 - Submittal Procedures
Section 01 33 23 - Shop Drawings, Product Data, and Samples
Section 01 42 19 - Reference Standards
Section 01 43 10 - Contractor Qualifications
Section 01 45 00 - Quality Control
Section 01 51 00 - Construction Facilities
Section 01 60 00 - Material and Equipment
Section 01 60 00A - Substitution Request Form
Section 01 64 00 - Receipt of Owner Furnished Materials
Section 01 71 13 - Mobilization and Demobilization
Section 01 71 23.16 - Construction Surveying
Section 01 73 00 - Execution Requirements
Section 01 74 00 - Cleaning and Waste Management
Section 01 77 00 - Contract Closeout Procedures
Section 01 77 00A - Certificate of Substantial Completion
Section 01 78 39 - Project Record Documents

DIVISION 02 - 33 - TECHNICAL SPECIFICATIONS

Section 02 32 00 - Geotechnical Investigations
Section 02 41 00 - Demolition
Section 02 61 13 - Excavation and Handling of Contaminated Material
Section 03 30 00 - Cast-In Place Concrete
Section 05 12 10 - Structural Steel Framing and Fabrications
Section 06 10 00 - Rough Carpentry
Section 06 17 53 - Shop Fabricated Wood Trusses
Section 07 21 00 - Thermal Insulation
Section 07 41 13 - Formed Metal Roof Panels

Section 07 42 13 - Formed Metal Wall Panels
Section 07 43 13 - Formed Vented Soffit Panels
Section 07 92 00 - Joint Sealant
Section 09 91 00 - Painting
Section 21 13 30 - High Pressure Water Mist Fire Suppression
Section 23 05 00 - Common Work Results for Mechanical
Section 23 05 29 - Hangers and Supports for Piping and Equipment
Section 23 07 19 - Piping Insulation
Section 23 09 00 - Instrumentation and Control Devices
Section 23 11 13 - Power Plant Fuel-Oil Piping
Section 23 12 13 - Power Plant Fuel-Oil Equipment and Specialties
Section 23 21 13 - Hydronic Piping
Section 23 21 16 - Hydronic Equipment and Specialties
Section 23 31 13 - Metal Ducts and Ventilation Equipment
Section 23 35 17 - Engine Exhaust Crank Vent and Charge Air Systems
Section 26 05 00 - Common Work Results for Electrical
Section 26 05 02 - Basic Electrical Materials and Methods
Section 26 05 26 - Grounding and Bonding for Electrical Systems
Section 26 05 29 - Hangers and Supports for Electrical Systems
Section 26 05 33 - Raceway and Boxes for Electrical Systems
Section 31 11 00 - Clearing and Grubbing
Section 31 23 00 - Excavation and Fill
Section 31 23 19 - Dewatering and Control of Surface Water
Section 31 23 33 - Trenching and Backfill For Utilities
Section 33 05 00 - Common Work Results for Utilities
Section 33 61 14 - PEX Arctic Pipe
Section 33 61 24 - Steel Arctic Pipe
Section 33 61 25 – Exterior Insulated Steel Pipe
Section 33 71 01 - Overhead Electrical Distribution
Section 33 71 16 - Wood Electrical Utility Poles
Section 33 73 01 - Overhead Liquid-Filled Transformers

DRAWINGS (Bound Separately)

Napaskiak Power System Upgrade Drawings

END TABLE OF CONTENTS

ALASKA ENERGY AUTHORITY

INVITATION TO BID

for Construction Contract

Date November 14, 2023

Napaskiak RPSU Project On Site Construction, Project No. 24078

Location of Project: Napaskiak, Alaska
Contract Administrator: Selwin Ray
Issuing Office: Alaska Energy Authority (Authority)
State Funded [] Federal Aid []

Description of Work: This Rural Utilities Service and State appropriation funded contract is for the installation of a new owner furnished modular power plant, installation of a new heat recovery system, and upgrade of an existing overhead electrical power distribution system in the community of Napaskiak, Alaska as described herein and shown in the Drawings. The Contractor shall furnish all labor, materials, supervision, equipment, tools, transportation, quality control, and supplies required to complete the work.

The Engineer's Estimate is between **\$2,000,000 and \$3,000,000**

All portions of the work shall be substantially completed by dates indicated in Section 01 11 13 - Summary of Work.

Bidders are invited to submit single bid, for furnishing all labor, equipment, and materials and for performing all work for the project described above. Bids will be opened publicly on **December 12, 2023** at **2:00 PM** local time. The bid opening will be conducted telephonically. Potential bidders may attend telephonically by calling **1-888-585-9008** and when prompted enter **351 122 943 #**.

SUBMISSION OF BIDS

ALL BIDS INCLUDING ANY AMENDMENTS OR WITHDRAWALS MUST BE RECEIVED PRIOR TO BID OPENING. BIDS SHALL BE SUBMITTED ON THE FORMS FURNISHED AND MUST BE MARKED AS FOLLOWS:

Bid for Project: Napaskiak RPSU Project On Site Construction Project No. 24078	ATTN: Selwin Ray, Contract Officer Alaska Energy Authority 813 West Northern Lights Blvd. Anchorage, AK 99503
---	--

Mailed Bids, amendments or withdrawals transmitted must be received in the above specified post office box no later than 4 hours prior to the scheduled time of bid opening. **Hand-delivered bids**, amendments or withdrawals must be received in the **Bid Drop Box in front of the Alaska Energy Authority**, prior to the scheduled time of bid opening. **Emailed bid** amendments or withdrawals must be received in the email inbox prior to the scheduled time of bid opening, addressed to, Email: AEAProcurement@akenergyauthority.org

A bid guaranty is required with each bid in the amount of 5% of the amount bid. (Alternate bid items as well as supplemental bid items appearing on the bid schedule shall be included as part of the total amount bid when determining the amount of bid guaranty required for the project.)

The Authority hereby notifies all bidders that it will affirmatively insure that in any contract entered into pursuant to this Invitation, Disadvantaged Business Enterprises (DBEs) will be afforded full opportunity to submit bids and will not be discriminated against on the grounds of race, color, national origin, or sex in consideration for an award.

NOTICE TO BIDDERS

Bidders are hereby notified that data to assist in preparing bids is available as follows:

See attached Special Notice to Bidders for this project.

Electronic Plans and Specifications may be ordered, for the price of \$0.00 from:

Alaska Energy Authority
813 West Northern Lights Blvd.
Anchorage, AK 99503

Phone: (907) 771-3035

All questions relating to design features, constructability, quantities, or other technical aspects of the project should be directed to the following. Bidders requesting assistance in viewing the project must make arrangements at least 48 hours in advance with:

Rebecca Garrett, Project Manager Phone: (907) 771- 3042 Email: rgarrett@akenergyauthority.org

All questions relating to bidding procedures should be directed to:

Selwin Ray
Contract Officer
813 West Northern Lights Blvd.
Anchorage, AK 99503
Phone: (907) 771-3035 Email: sray@akenergyauthority.org

The Bid Calendar, Planholder lists, and Bid Results information are available on the Internet at:
<http://www.akenergyauthority.org/> under Procurement Opportunities.

Reminder: 3 AAC 109.220 requires all Bidders to have a valid Alaska Business License and an Alaska Contractor's Certificate of Registration prior to award.

ALASKA ENERGY AUTHORITY
INFORMATION TO BIDDERS

The Authority is concerned over the manner in which bids are submitted. Bidders are requested to study and follow the bid assembly instructions as to the method and form for submitting bids so there will be no reason to reject a bid.

EXAMINATION OF CONTRACT REQUIREMENTS

Bidders are expected to examine carefully the plans, specifications and all other documents incorporated in the contract to determine the requirements thereof before preparing bids.

Any explanation desired by bidders regarding the meaning or interpretation of drawings and specifications must be requested in writing and with sufficient time allowed for a reply to reach them before the submission of their bids. Oral explanations or instructions given before the award of the contract will not be binding. Any interpretation made will be in the form of an addendum to the specifications or drawings and will be furnished to all bidders and its receipt by the bidder shall be acknowledged.

CONDITIONS AT SITE OF WORK

Bidders are expected to visit the site to ascertain pertinent local conditions such as the location, accessibility and character of the site, labor conditions, the character and extent of the existing work within or adjacent thereto, and any other work being performed thereon.

PREPARATION OF BIDS

- (a) Bids shall be submitted on the forms furnished, and must be manually signed in ink. The person signing the proposal must initial any erasures or changes made to the bid.
- (b) The bid schedule will provide for quotation of a price or prices for one or more pay items which may include unit price or lump sum items and alternative, optional or supplemental price schedules or a combination thereof which will result in a total bid amount for the proposed construction.

Where required on the bid form, bidders must quote on all items and **THEY ARE WARNED** that failure to do so will disqualify them. When quotations on all items are not required, bidders should insert the words "no bid" in the space provided for any item not requiring a quotation and for which no quotation is made.

- (c) The bidder shall specify the price or prices bid in figures. On unit price contracts the bidder shall also show the products of the respective unit prices and quantities written in figures in the column provided for the purpose and the total amount of the proposal obtained by adding the amounts of the several items. All the figures shall be in ink or typed.
- (d) Neither conditional nor alternative bids will be considered unless called for.
- (e) Unless specifically called for, telegraphic or telefacsimile bids will not be considered.
- (f) Bid Schedule form should be enclosed in a separate sealed envelope and enclosed with all other bidding forms required at the opening.

BID SECURITY

All bids shall be accompanied by a bid security in the form of an acceptable Bid Bond (Form 25D-14), or a certified check, cashier's check or money order made payable to the Alaska Energy Authority. The amount of the bid security is specified on the Invitation To Bid.

Bid Bonds must be accompanied by a legible Power of Attorney.

If the bidder fails to furnish an acceptable bid security with the bid, the bid shall be rejected as non-responsive. Telegraphic notification of execution of Bid Bond does not meet the requirements of bid security accompanying the bid. An individual surety will not be accepted as a bid security.

The Authority will hold the bid securities of the two lowest bidders until the Contract has been executed, after which they will be returned. All other bid securities will be returned as soon as practicable.

BIDDERS QUALIFICATIONS

Before a bid is considered for award, the bidder may be requested by the Authority to submit a statement of facts, in detail, as to his previous experience in performing comparable work, his business and technical organization, financial resources, and plant available to be used in performing the contemplated work.

SUBMISSION OF BIDS

Bids must be submitted as directed on the Invitation To Bid. Do not include in the envelope any bids for other work.

ADDENDA REQUIREMENTS

The bid documents provide for acknowledgement individually of all addenda to the drawings and/or specifications on the signature page of the Proposal. All addenda shall be acknowledged on the Proposal or by telegram prior to the scheduled time of bid opening. If the bidder received no addenda, the word "None" should be shown as specified.

Every effort will be made by the Authority to insure that Contractors receive all addenda when issued. Addenda will be issued to the individual or company to whom bidding documents were issued. Addenda may be issued by any reasonable method such as hand delivery, mail, telefacsimile, telegraph, courier, and in special circumstances by phone. Addenda will be issued to the address, telefacsimile number or phone number as stated on the planholder's list unless picked up in person or included with the bid documents. It is the bidder's responsibility to insure that he has received all addenda affecting the Invitation To Bid. No claim or protest will be allowed based on the bidder's allegation that he did not receive all of the addenda for an Invitation To Bid.

All questions must be received 72 hours before the bid opening. Questions submitted after the deadline may be rejected by the Authority.

WITHDRAWAL OR REVISION OF BIDS

A bidder may withdraw or revise a bid after it has been deposited with the Authority, provided that the request for such withdrawal or revision is received by the designated office, in writing, by telegram, or by telefacsimile, before the time set for opening of bids.

Emailed or telefacsimile modifications shall include both the modification of the unit bid price and the total modification of each item modified, but shall not reveal the amount of the total original or revised bids. Form 25D-16 shall be used to submit such modifications.

RECEIPT AND OPENING OF BIDS

- (a) The Authority must receive all bids, including any amendment or withdrawal prior to the scheduled time of bid opening. Any bid, amendment, or withdrawal that has not actually been received by the Authority prior to the time of the scheduled bid opening will not be considered.
- (b) No responsibility will be attached to any officer or employee of the Authority for the premature opening of, or failure to open, a bid improperly addressed or identified.
- (c) The Authority reserves the right to waive any technicality in bids received when such waiver is in the interest of the State.

BIDDERS PRESENT

At the time fixed for bid opening, bids will be publicly opened and read for the information of bidders and others properly interested, who may be present either in person or by representative. The amount of the bid and the name of the bidder shall be compiled and distributed as soon as possible after bid opening. Bids are not open for public inspection until after the Notice of Intent to Award is issued.

BIDDERS INTERESTED IN MORE THAN ONE BID

If more than one bid is offered by any one party, by or in the name of his or their clerk or partner, all such bids will be rejected. A party who has quoted prices to a bidder is not thereby disqualified from quoting prices to other bidders or from submitting a bid directly for the work.

REJECTION OF BIDS

The Authority reserves the right to reject any and all bids when such rejection is in the best interest of the State; to reject the bid of a bidder who has previously failed to perform properly, or complete on time, contracts of a similar nature; to reject the bid of a bidder who is not, in the opinion of the Contracting Officer, in a position to perform the contract; and to reject a bid as non-responsive where the bidder fails to furnish the required documents, fails to complete required documents in the manner directed, or makes unauthorized alterations to the bid documents.

AWARD OF CONTRACT

- (a) The letter of award, if the contract is to be awarded, will be issued to the lowest responsible and responsive bidder as soon as practical and usually within 40 calendar days after opening of proposals.
- (b) The successful bidder will be notified of the Authority's intent to award the contract and requested to execute certain documents, including the contract form and bonds.
- (c) The contract will be awarded to the successful bidder following receipt by the Authority of all required documents, properly executed, within the time specified in the intent to award. Failure to enter into a contract within the specified time shall be grounds for forfeiture of the bid security and consideration of the second low bidder for award.

ALASKA ENERGY AUTHORITY

SUPPLEMENTARY INFORMATION TO BIDDERS

This document modifies or adds to the provisions of Alaska Energy Authority's form 25D-3, INFORMATION TO BIDDERS.

Following subject area "REJECTION OF BIDS", add the following subject area:

"CONSIDERATION OF PROPOSALS

After the Proposals are opened and read, they will be compared on the basis identified on the bid schedule and the apparent low Bidder announced. The apparent low Bidder shall, within 5 working days following identification as the apparent low Bidder, submit a list of all firms with which the prime CONTRACTOR intends to execute subcontracts for the performance of the Contract. The list shall include the name, business address, Alaska business license number, and contractor's registration number of each proposed Subcontractor.

Upon confirmation of the contents of the proposal the low Bidder will be identified by the AUTHORITY in writing. If the low Bidder differs from the apparent low Bidder then the requirements for Subcontractor listing, as noted above, shall become effective upon the low Bidder at the time of identification.

If a Bidder fails to list a Subcontractor or lists more than one Subcontractor for the same portion of Work and the value of that Work is in excess of one-half of one percent of the total bid, the Bidder agrees that it shall be considered to have agreed to perform that portion of Work without the use of a Subcontractor and to have represented that the Bidder is qualified to perform the Work.

A Bidder who attempts to circumvent the requirements of this section by listing as a Subcontractor another contractor who, in turn, sublets the majority of the Work required under the Contract, violates this section.

If a Contract is awarded to a Bidder who violates this section, the Bidder agrees that the Contracting Officer may:

- (1) cancel the Contract without any damages accruing to the State; or
- (2) after notice and a hearing, assess a penalty on the Bidder in an amount that does not exceed 10 percent of the value of the Subcontract at issue.

A Bidder may replace a listed Subcontractor who:

- (1) fails to comply with AS 08.18;
- (2) files for bankruptcy or becomes insolvent;
- (3) fails to execute a contract with the Bidder involving performance of the Work for which the Subcontractor was listed and the Bidder acted in good faith;
- (4) fails to obtain bonding;
- (5) fails to obtain insurance acceptable to the State;
- (6) fails to perform the Contract with the Bidder involving Work for which the Subcontractor was listed;
- (7) must be substituted in order for the prime CONTRACTOR to satisfy required State and Federal affirmative action requirements;
- (8) refuses to agree or abide with the bidder's labor agreement; or
- (9) is determined by the Contracting Officer to be nonresponsive."

Modify subject area "AWARD OF CONTRACT" as follows:

Subparagraph (a) substitute the word "generally" for the phrase "as soon as practical and"

Subparagraph (b) delete and substitute the following:

"All Bidders will be notified of the AUTHORITY's intent to Award the Contract and the successful Bidder will be requested to execute certain documents, including the Contract form and bonds."

Special Notice to Bidders

1. A non-mandatory pre-bid meeting is scheduled for **November 21, 2023, 10:00 AM. The pre-bid meeting will be conducted telephonically.** Potential bidders may attend telephonically by calling **1-888-585-9008**, when prompted enter **351 122 943 #**. If calling in, please be respectful of other callers and call from a phone that can be muted so as to cancel out background noise and the possibility of feedback. Contact the Contract Officer, Selwin Ray, at (907) 771-3035 for more information. This is not a mandatory meeting, and there will not be a scheduled site visit prior to the bid opening.

REQUIRED DOCUMENTS

REQUIRED FOR BID. Bids will not be considered if the following documents are not completely filled out and submitted at the time of bidding:

1. **Bid Form (Form 25D-9)**
 2. **Bid Schedule**
 3. **Bid Security**
 4. Any bid revisions must be submitted by the bidder prior to bid opening on the following form:
Bid Modification (Form 25D-16)
-

REQUIRED AFTER NOTICE OF APPARENT LOW BIDDER. The apparent low bidder is required to complete and submit the following document within 5 working days after receipt of written notification:

1. **Subcontractor List (Form 25D-5)**
-

REQUIRED FOR AWARD. In order to be awarded the contract, the successful bidder must completely fill out and submit the following documents within the time specified in the intent to award letter:

1. **Construction Contract (Form 25D-10A)**
2. **Payment Bond (Form 25D-12)**
3. **Performance Bond (Form 25D-13)**
4. **Contractor's Questionnaire (Form 25D-8)**
5. **Certificate of Insurance (from carrier)**

FEDERAL EEO BID CONDITIONS

STANDARD FEDERAL EQUAL EMPLOYMENT OPPORTUNITY CONSTRUCTION CONTRACT SPECIFICATIONS (EXECUTIVE ORDER 11246). FOR ALL NON-EXEMPT FEDERAL AND FEDERALLY-ASSISTED CONSTRUCTION CONTRACTS TO BE AWARDED IN THE STATE OF ALASKA

1. Definitions. As used in these specifications:
 - a. “**Covered area**” means the geographical area described in the solicitation from which this contract resulted;
 - b. “**Director**” means Director, Office of Federal Contract Compliance Programs (OFCCP), United States Department of Labor (DOL), or any persons to whom the Director delegates authority;
 - c. “**Employer**” identification number” means the Federal Social Security number used on the Employer’s Quarterly Federal Tax Return, U.S. Treasury Department Form 941.
 - d. “**Minority**” includes:
 - (1) Black (all persons having origins in any of the Black African racial groups not of Hispanic origin);
 - (2) Hispanic (all persons of Mexican, Puerto Rican, Cuban, Central or South American or other Spanish culture or origin, regardless of race);
 - (3) Asian and Pacific Islander (all persons having origins in any of the original peoples of the Far East, Southeast Asia, the Indian Subcontinent, or the Pacific Islands); and
 - (4) American Indian or Alaska Native (all persons having origins in any of the original peoples of North America and maintaining identifiable tribal affiliations through membership and participation or community identification).
2. Whenever the Contractor, or any subcontractor at any tier, subcontracts a portion of the work involving any construction trade, it shall physically include in each subcontract in excess of \$10,000 the provisions of these specifications and the Notice which contains the applicable goals for minority and female participation and which is set forth in the solicitations from which this contract resulted.
3. If the Contractor is participating (pursuant to 41 CFR 60-4.5) in a Hometown Plan approved by the DOL in the covered area, either individually or through an association, its affirmative action obligations on all work in the Plan area (including goals and timetables) shall be in accordance with that Plan for those trades that have unions participating in the Plan. Contractors must be able to demonstrate their participation in and compliance with the provisions of any such Hometown Plan. Each Contractor or subcontractor participating in an approved Plan is individually required to comply with its obligations under the EEO clause, and to make good faith effort to achieve each goal under the Plan in each trade in which it has employees. The overall good faith performance by other Contractors or subcontractors toward a goal in an approved Plan does not excuse any covered Contractor’s or subcontractor’s failure to make good faith efforts to achieve the Plan goals and timetables.
4. The Contractor shall implement the specific affirmative action standards provided in paragraphs 7(a) through 7(p) of these specifications. The goals set forth in the solicitation from which this contract resulted are expressed as percentages of the total hours of employment and training of minority and female utilization the Contractor should reasonably be able to achieve in each construction trade in which it has employees in the covered area. The Contractor is expected to make substantially uniform progress toward its goals in each craft during the period specified.

Covered construction contractors performing construction work in geographical areas where they do not have a federal or federally-assisted construction contract shall apply the minority and female goals established for the geographical area where the work is being performed. Goals are published periodically in the Federal Register in notice form, and such notices may be obtained from any OFCCP office or from federal procurement contracting officers.

5. Neither the provisions of any collective bargaining agreement, nor the failure by a union with whom the Contractor has a collective bargaining agreement, to refer either minorities or women shall excuse the Contractor's obligations under these specifications, Executive Order 11246, or the regulations promulgated pursuant thereto.
6. In order for the non-working training hours of apprentices and trainees to be counted in meeting the goals, such apprentices and trainees must be employed by the Contractor during the training period of an approved training program and the Contractor must have made a commitment to employ the apprentices and trainees at the completion of their training, subject to the availability of employment opportunities.
7. The Contractor shall take specific affirmative actions to ensure equal employment opportunity. The evaluation of the Contractor's compliance with these specifications shall be based upon its effort to achieve maximum results from its actions. The Contractor shall document these efforts fully, and shall implement affirmative action steps at least as extensive as the following:
 - a. Ensure and maintain a working environment free of harassment, intimidation, and coercion at all sites, and in all facilities at which the Contractor's employees are assigned to work. The Contractor, where possible, will assign two or more women to each construction project. The Contractor shall specifically ensure that all foremen, superintendents, and other on-site supervisory personnel are aware of and carry out the Contractor's obligations to maintain such a working environment, with specific attention to minority or female individuals working at such sites or in such facilities.
 - b. Establish and maintain a current list of minority and female recruitment sources, provide written notification to minority and female recruitment sources and to community organizations when the Contractor or its unions have employment opportunities available, and maintain a record of the organizations' responses.
 - c. Maintain a current file of the names, addresses and telephone numbers of each minority and female off-the-street applicant and minority or female referral from a union, a recruitment source or community organization and of what action was taken with respect to each such individual. If such individual was sent to the union hiring hall for referral and was not referred back to the Contractor by the union or, if referred, not employed by the Contractor, this shall be documented in the file with the reason therefor, along with whatever additional actions the Contractor may have taken.
 - d. Provide immediate written notification to the Director when the union or unions with which the Contractor has a collective bargaining agreement has not referred to the Contractor a minority person or woman sent by the Contractor, or when the Contractor has other information that the union referral process has impeded the Contractor's efforts to meet its obligations.
 - e. Develop on-the-job training opportunities and/or participate in training programs for the area which expressly include minorities and women, including upgrading programs and apprenticeship and trainee programs relevant to the Contractor's employment needs, especially those programs funded or approved by the DOL. The Contractor shall provide notice of these programs to the sources compiled under 7(b) above.
 - f. Disseminate the Contractor's EEO policy by providing notice of the policy to unions and training programs and requesting their cooperation in assisting the Contractor in meeting its EEO obligations; by including it in any policy manual and collective bargaining agreement; by publicizing it in the company newspaper, annual report, etc.; by specific review of the policy with all management personnel and with all minority and female employees at least once a year; and by posting the company EEO policy on bulletin boards accessible to all employees at each location where construction work is performed.

- g. Review, at least annually, the company's EEO policy and affirmative action obligations under these specifications with all employees having any responsibility for hiring, assignment, layoff, termination or other employment decisions including specific review of these items with on-site supervisory personnel such as Superintendent, general foreman, etc., prior to the initiation of construction work at any job site. A written record shall be made and maintained identifying the time and place of these meetings, persons attending, subject matter discussed, and dispositions of the subject matter.
 - h. Disseminate the Contractor's EEO policy externally by including it in any advertising in the news media, specifically including minority and female news media, and providing written notification to and discussing the Contractor's EEO policy with other Contractors and Subcontractors with whom the Contractor does or anticipates doing business.
 - i. Direct its recruitment efforts, both oral and written, to minority, female and community organizations, to schools with minority and female students and to minority and female recruitment and training organizations serving the Contractor's recruitment area and employment needs. Not later than one month prior to the date for the acceptance of applications for apprenticeship or other training by any recruitment source, the Contractor shall send written notification to organizations such as the above, describing the openings, screening procedures, and tests to be used in the selection process.
 - j. Encourage present minority and female employees to recruit other minority persons and women and, where reasonable, provide after school, summer and vacation employment to minority and female youth both on the site and in other areas of a Contractor's workforce.
 - k. Validate all tests and other selection requirements where there is an obligation to do so under 41 CFR Part 60-3.
 - l. Conduct, at least annually, an inventory and evaluation at least of all minority and female personnel for promotional opportunities and encourage these employees to seek or to prepare for, through appropriate training, etc., such opportunities.
 - m. Ensure that seniority practices, job classifications, work assignments and other personnel practices do not have a discriminatory effect by continually monitoring all personnel and employment related activities to ensure that the EEO policy and the Contractor's obligations under these specifications are being carried out.
 - n. Ensure that all facilities and company activities are nonsegregated except that separate or single-used toilet, necessary changing facilities and necessary sleeping facilities shall be provided to assure privacy between the sexes.
 - o. Document and maintain a record of all solicitations of offers for subcontractors from minority and female construction contractors and suppliers, including circulations of solicitations to minority and female contractor associations and other business associations.
 - p. Conduct a review, at least annually, of all supervisors' adherence to and performance under the Contractor's EEO policies and affirmative action obligations.
8. Contractors are encouraged to participate in voluntary associations which assist in fulfilling one or more of their affirmative action obligations 7(a) through 7(p). The efforts of a contractor association, joint contractor-union, contractor-community, or other similar group of which the Contractor is a member and participant, may be asserted as fulfilling any or more of its obligations under 7(a) through 7(p) of these specifications provided that the Contractor actively participates in the group, makes every effort to assure that the group has a positive impact on the employment of minorities and women in the industry, ensures that the concrete benefits of the program are reflected in the Contractor's minority and female work force participation, makes a good faith effort to meet its individual goals and timetables, and can provide access to documentation which demonstrates the effectiveness of actions taken on behalf of the Contractor. The obligation to comply, however, is the Contractor's and failure of such a group to fulfill an obligation shall not be a defense for the Contractor's noncompliance.

9. A single goal for minorities and a separate goal for women have been established. The Contractor, however, is required to provide equal employment opportunity and to take affirmative action for all minority groups, both male and female, and all women, both minority and non-minority. Consequently, the Contractor may be in violation of the Executive Order if a particular group is employed in a substantially disparate manner (for example, even though the Contractor has achieved its goals for women generally, the Contractor may be in violation of the Executive Order if a specific minority group of women is underutilized.)
10. The Contractor shall not use the goals and timetables or affirmative action standards to discriminate against any person because of race, color, religion, sex, or national origin.
11. The Contractor shall not enter into any subcontract with any person or firm debarred from government contracts pursuant to Executive Order 11246.
12. The Contractor shall carry out such sanctions and penalties for violation of these specifications and of the Equal Opportunity Clause, including suspension, termination and cancellation of existing subcontracts as may be imposed or ordered pursuant to Executive Order 11246, as amended, and its implementing regulations, by the OFCCP. Any Contractor who fails to carry out such sanctions and penalties shall be in violation of these specifications and Executive Order 11246, as amended.
13. The Contractor, in fulfilling its obligations under these specifications, shall implement specific affirmative action steps, at least as extensive as those standards prescribed in paragraph 7 of these specifications, so as to achieve maximum results from its efforts to ensure equal employment opportunities. If the Contractor fails to comply with the requirements of the Executive Order, the implementing regulations or these specifications, the Director shall proceed in accordance with 41 CFR 60-4.8.
14. The Contractor shall designate a responsible official to monitor all employment related activity to ensure that the company EEO policy is being carried out, to submit reports relating to the provisions hereof as may be required by the Government and to keep records. Records shall at least include for each employee the name, address, telephone numbers, construction trade, union affiliation if any, employee identification number when assigned, social security number, race, sex, status (e.g., mechanic apprentice, trainees, helper, or laborer), dates of changes in status, hours worked per week in the indicated trade, rate of pay, and locations at which the work was performed. Records shall be maintained in an easily understandable and retrievable form; however, to the degree that the existing records satisfy this requirement, Contractors shall not be required to maintain separate records.
15. Nothing herein provided shall be construed as a limitation upon the application of other laws that establish different standards of compliance or upon the application of requirements for the hiring of local or other area residents (e.g., those under the Public Works Employment Act of 1977 and the Community Development Block Grant Programs).
16. The Bidder's attention is called to the "Equal Opportunity Clause" and the "Standard Federal Equal Employment Opportunity Construction Contract Specifications" set forth herein.
17. The Contractor shall provide written notification to the Department, for all subcontracts documents as follows: the name, address and telephone number of subcontractors and their employer identification number; the estimated dollar amount of the subcontracts; estimated starting and completion dates of the subcontracts; and the geographical area in which the contract is to be performed.

This written notification shall be required for all construction subcontracts in excess of \$10,000 at any tier for construction work under the contract resulting from this project's solicitation.
18. As used in the Bid Notice, and in the contract resulting from this project's solicitation, the "covered area" is the State of Alaska.

PROPOSAL
of

NAME _____

ADDRESS _____

To the CONTRACTING OFFICER, ALASKA ENERGY AUTHORITY:

In compliance with your Invitation To Bid dated **December 12, 2023**, the Undersigned proposes to furnish and deliver all the materials and do all the work and labor required in the construction of Project:

Project Name

Napaskiak RPSU Project On Site Construction
Project No. 24078

Located at **Napaskiak, Alaska**, according to the plans and specifications and for the amount and prices named herein as indicated on the Bid Schedule consisting of 2 sheet(s), which is made a part of this Bid.

The Undersigned declares that he has carefully examined the contract requirements and that he has made a personal examination of the site of the work; that he understands that the quantities, where such are specified in the Bid Schedule or on the plans for this project, are approximate only and subject to increase or decrease, and that he is willing to perform increased or decreased quantities of work at unit prices bid under the conditions set forth in the Contract Documents.

The Undersigned hereby agrees to execute the said contract and bonds within fifteen calendar days, or such further time as may be allowed in writing by the Contracting Officer, after receiving notification of the acceptance of this proposal, and it is hereby mutually understood and agreed that in case the Undersigned does not, the accompanying bid guarantee shall be forfeited to the Alaska Energy Authority, as liquidated damages, and the said Contracting officer may proceed to award the contract to others.

The Undersigned agrees to commence the work within 10 calendar days of the effective date of Notice to Proceed and to Substantially Complete the work by the **date(s) indicated in Section 01 11 13 - Summary of Work** unless extended in writing by the Contracting Officer.

The Undersigned proposes to furnish Payment Bond in the amount of 100% (of the contract) and Performance Bond in the amount of 100% (of the contract), as surety conditioned for the full, complete and faithful performance of this contract.

The Undersigned acknowledges receipt of the following addenda to the drawings and/or specifications (give number and date of each).

Addendum Number	Date Issued

Addendum Number	Date Issued

Addendum Number	Date Issued

NON-COLLUSION AFFIDAVIT

The Undersigned declares, under penalty of perjury under the laws of the United States, that neither he nor the firm, association, or corporation of which he is a member, has, either directly or indirectly, entered into any agreement, participated in any collusion, or otherwise taken any action in restraint of free competitive bidding in connection with this bid.

The Undersigned has read the foregoing proposal and hereby agrees to the conditions stated therein by affixing his signature below:

Signature

Name and Title of Person Signing

Telephone Number

Fax Number

BID SCHEDULE

**Napaskiak RPSU Project On Site Construction
Project No. 24078**

Bidders Please Note: Before preparing this bid schedule, read carefully, "Information to Bidders", and the following:

The Bidder shall insert a fixed price in figures opposite each pay item that appears on the bid schedule to furnish all labor, material, equipment, supervision and provide all work for each item listed. No price is to be entered or tendered for any item not appearing in the bid schedule. In case of error in the extension of prices in the bid, the unit prices will govern.

Contract award shall be made based on the Base Bid. AEA reserves the right to award none or any number of alternates in any order in the best interest of the State.

Bidders are required to bid on all bid items. Conditioned or qualified bids will be considered non-responsive.

Bid Item	Description	Lump Sum Price
1	Base Bid	\$
2	Additive Alternate #1	\$
3	Additive Alternate #2	\$
4	Additive Alternate #3	\$
5	Additive Alternate #4	\$

See Specification Section 01 11 13 Summary of Work and Drawings for detailed descriptions of each bid item.

2. Acknowledge all addenda

Addendum No	Date Issued	Addendum No	Date Issued	Addendum No	Date Issued

3. BIDDER’S NOTICE: By signature on this form, the Bidder certifies that:

- a. The price(s) submitted are independent and without collusion.**
- b. The Bidder will comply with the laws of the State of Alaska;**

- c. The Bidder will comply with applicable portions of the Federal Civil Rights Act of 1964;
- d. The Bidder will comply with the Equal Employment Opportunity Act and the regulations issued there under by the State and Federal Government; and
- e. The Bidder has reviewed all terms and conditions in this Invitation to Bid.

If any Bidder fails to comply with any of these requirements, the Authority may reject its bid, terminate the contract, or consider the Vendor in default.

Company Submitting Bid	Telephone Number
Address	Fax Number
Authorized Signature	E-mail Address
Print Name	Alaska Business License number: _____ EXPRES DATE: _____
	Alaska Contractor's Registration # _____ EXPRES DATE: _____

End of Bid Schedule.

ALASKA ENERGY AUTHORITY

BID BOND

For

Napaskiak RPSU Project On Site Construction

Project No. 24078

DATE BOND EXECUTED: _____

PRINCIPAL (Legal name and business address):

TYPE OF ORGANIZATION:

	[] Individual	[] Partnership
	[] Joint Venture	[] Corporation
STATE OF INCORPORATION:		

SURETY(IES) (Name and business address):

A.	B.	C.
PENAL SUM OF BOND:		DATE OF BID:

We, the PRINCIPAL and SURETY above named, are held and firmly bound to the State (State of Alaska), in the penal sum of the amount stated above, for the payment of which sum will be made, we bind ourselves and our legal representatives and successors, jointly and severally, by this instrument.

THE CONDITION OF THE FOREGOING OBLIGATION is that the Principal has submitted the accompanying bid in writing, date as shown above, on the above-referenced Project in accordance with contract documents filed in the office of the Contracting Officer, and under the Invitation To Bid therefore, and is required to furnish a bond in the amount stated above.

If the Principal's bid is accepted and he is offered the proposed contract for award, and if the Principal fails to enter into the contract, then the obligation to the State created by this bond shall be in full force and effect.

If the Principal enters into the contract, then the foregoing obligation is null and void.

PRINCIPAL

Signature(s)	1.	2.	3.
Name(s) & Title(s) (Typed)	1.	2.	3.

Corporate Seal

See Instructions on Reverse

CORPORATE SURETY(IES)

Surety A	Name of Corporation	State of Incorporation	Liability Limit \$
Signature(s)	1.	2.	Corporate Seal
Name(s) & Titles (Typed)	1.	2.	
Surety B	Name of Corporation	State of Incorporation	Liability Limit \$
Signature(s)	1.	2.	Corporate Seal
Name(s) & Titles (Typed)	1.	2.	
Surety C	Name of Corporation	State of Incorporation	Liability Limit \$
Signature(s)	1.	2.	Corporate Seal
Name(s) & Titles (Typed)	1.	2.	

INSTRUCTIONS

1. This form shall be used whenever a bid bond is submitted.
2. Insert the full legal name and business address of the Principal in the space designated. If the Principal is a partnership or joint venture, the names of all principal parties must be included (e.g., "Smith Construction, Inc. and Jones Contracting, Inc. DBA Smith/Jones Builders, a joint venture"). If the Principal is a corporation, the name of the state in which incorporated shall be inserted in the space provided.
3. Insert the full legal name and business address of the Surety in the space designated. The Surety on the bond may be any corporation or partnership authorized to do business in Alaska as an insurer under AS 21.09. Individual sureties will not be accepted.
4. The penal amount of the bond may be shown either as an amount (in words and figures) or as a percent of the contract bid price (a not-to-exceed amount may be included).
5. The scheduled bid opening date shall be entered in the space marked Date of Bid.
6. The bond shall be executed by authorized representatives of the Principal and Surety. Corporations executing the bond shall also affix their corporate seal.
7. Any person signing in a representative capacity (e.g., an attorney-in-fact) must furnish evidence of authority if that representative is not a member of the firm, partnership, or joint venture, or an officer of the corporation involved.
8. The states of incorporation and the limits of liability of each surety shall be indicated in the spaces provided.
9. The date that bond is executed must not be later than the bid opening date.

CONSTRUCTION CONTRACT
Napaskiak RPSU Project On Site Construction
Project No. 24078

This CONTRACT, between the ALASKA ENERGY AUTHORITY, herein called the Authority, acting by and through its Contracting Officer, and

Company Name

Company Address (Street or PO Box, City, State, Zip)

a/an Individual Partnership Joint Venture Sole Proprietorship Corporation incorporated under the laws of the State of _____, its successors and assigns, herein called the Contractor, is effective the date of the signature of the Contracting Officer on this document.

WITNESSETH: That the Contractor, for and in consideration of the payment or payments herein specified and agreed to by the Department, hereby covenants and agrees to furnish and deliver all the materials and to do and perform all the work and labor required in the construction of the above-referenced project at the prices bid by the Contractor for the respective estimated quantities aggregating approximately the sum of

Dollars (\$ _____), and such other items as are mentioned in the original Bid, which Bid and prices named, together with the Contract Documents are made a part of this Contract and accepted as such.

It is distinctly understood and agreed that no claim for additional work or materials, done or furnished by the Contractor and not specifically herein provided for, will be allowed by the Authority, nor shall the Contractor do any work or furnish any material not covered by this Contract, unless such work is ordered in writing by the Authority. In no event shall the Authority be liable for any materials furnished or used, or for any work or labor done, unless the materials, work, or labor are required by the Contract or on written order furnished by the Authority. Any such work or materials which may be done or furnished by the Contractor without written order first being given shall be at the Contractor's own risk, cost, and expense and the Contractor hereby covenants and agrees to make no claim for compensation for work or materials done or furnished without such written order.

The Contractor further covenants and agrees that all materials shall be furnished and delivered and all labor shall be done and performed, in every respect, to the satisfaction of the Authority, on or before,

Substantially Completed by: **Date(s) indicated in Section 01 11 13 - Summary of Work**
Final Completion: **Date(s) indicated in Section 01 11 13 - Summary of Work**

It is expressly understood and agreed that in case of the failure on the part of the Contractor, for any reason, except with the written consent of the Authority, to complete the furnishing and delivery of materials and the doing and performance of the work before the aforesaid date, the Authority shall have the right to deduct from any money due or which may become due the Contractor, or if no money shall be due, the Authority shall have the right to recover **Five Hundred Dollars (\$500.00)** per day for each calendar day elapsing between the time stipulated for the completion and the actual date of completion up to a maximum of **\$10,000 (20 days)** in accordance with the terms hereof; such deduction to be made, or sum to be recovered, not as a penalty but as liquidated damages.

The bonds given by the Contractor in the sum of \$ _____ Payment Bond, and \$ _____ Performance Bond, to secure the proper compliance with the terms and provisions of this Contract, are submitted herewith and made a part hereof.

IN WITNESS WHEREOF, the parties hereto have executed this Contract and hereby agree to its terms and conditions.

CONTRACTOR

Company Name

Signature of Authorized Company Representative

Typed Name and Title

Date

(Corporate Seal)

ALASKA ENERGY AUTHORITY

Signature of Contracting Officer

Typed Name

Date

ALASKA ENERGY AUTHORITY

PERFORMANCE BOND

Bond No. _____

For

**Napaskiak RPSU Project On Site Construction
Project No. 24078**

KNOW ALL WHO SHALL SEE THESE PRESENTS:

That _____
of _____ as Principal,
and _____
of _____ as Surety,
firmly bound and held unto the State of Alaska in the penal sum of _____ Dollars

(\$ _____) good and lawful money of the United States of America for the payment whereof, well and truly to be paid to the State of Alaska, we bind ourselves, our heirs, successors, executors, administrators, and assigns, jointly and severally, firmly by these presents.

WHEREAS, the said Principal has entered into a written contract with said State of Alaska, on the _____ of _____ A.D., 20____, for construction of the above-named project, said work to be done according to the terms of said contract.

Now, THEREFORE, the conditions of the foregoing obligation are such that if the said Principal shall well and truly perform and complete all obligations and work under said contract and if the Principal shall reimburse upon demand of the Alaska Energy Authority any sums paid him which exceed the final payment determined to be due upon completion of the project, then these presents shall become null and void; otherwise they shall remain in full force and effect.

IN WITNESS WHEREOF, we have hereunto set our hands and seals at _____, this _____ day of _____ A.D., 20____.

Principal: _____

Address: _____

By: _____

Contact Name: _____

Phone: () _____

Surety: _____

Address: _____

By: _____

Contact Name: _____

Phone: () _____

The offered bond has been checked for adequacy under the applicable statutes and regulations:

Alaska Energy Authority Authorized Representative

Date

See Instructions on Reverse

INSTRUCTIONS

1. This form shall be used whenever a performance bond is required. There shall be no deviation from this form without approval from the Contracting Officer.
2. The full legal name, business address, phone number, and point of contact of the Principal and Surety shall be typed on the face of the form. Where more than a single surety is involved, a separate form shall be executed for each surety.
3. The penal amount of the bond, or in the case of more than one surety the amount of obligation, shall be typed in words and in figures.
4. Where individual sureties are involved, a completed Affidavit of Individual Surety shall accompany the bond. Such forms are available upon request from the Contracting Officer.
5. The bond shall be signed by authorized persons. Where such person is signing in a representative capacity (e.g., an attorney-in-fact), but is not a member of the firm, partnership, or joint venture, or an officer of the corporation involved, evidence of authority must be furnished.

ALASKA ENERGY AUTHORITY

PAYMENT BOND

Bond No. _____

For
Napaskiak RPSU Project On Site Construction
Project No. 24078

NOW ALL WHO SHALL SEE THESE PRESENTS:

That _____
of _____ as Principal,
and _____
of _____ as Surety,
firmly bound and held unto the State of Alaska in the penal sum of _____ Dollars

(\$ _____) good and lawful money of the United States of America for the payment whereof, well and truly to be paid to the State of Alaska, we bind ourselves, our heirs, successors, executors, administrators, and assigns, jointly and severally, firmly by these presents.

WHEREAS, the said Principal has entered into a written contract with said State of Alaska, on the _____ of _____ A.D., 20____, for construction of the above-referenced project, said work to be done according to the terms of said contract.

Now, THEREFORE, the conditions of the foregoing obligation are such that if the said Principal shall comply with all requirements of law and pay, as they become due, all just claims for labor performed and materials and supplies furnished upon or for the work under said contract, whether said labor be performed and said materials and supplies be furnished under the original contract, any subcontract, or any and all duly authorized modifications thereto, then these presents shall become null and void; otherwise they shall remain in full force and effect.

IN WITNESS WHEREOF, we have hereunto set our hands and seals at _____, _____ this _____ day of _____ A.D., 20____.

Principal: _____

Address: _____

By: _____

Contact Name: _____

Phone: () _____

Surety: _____

Address: _____

By: _____

Contact Name: _____

Phone: () _____

The offered bond has been checked for adequacy under the applicable statutes and regulations:

Alaska Energy Authority Authorized Representative

Date

See Instructions on Reverse

INSTRUCTIONS

1. This form, for the protection of persons supplying labor and material, shall be used whenever a payment bond is required. There shall be no deviation from this form without approval from the Contracting Officer.
2. The full legal name, business address, phone number, and point of contact of the Principal and Surety shall be typed on the face of the form. Where more than a single surety is involved, a separate form shall be executed for each surety.
3. The penal amount of the bond, or in the case of more than one surety the amount of obligation, shall be typed in words and in figures.
4. Where individual sureties are involved, a completed Affidavit of Individual Surety shall accompany the bond. Such forms are available upon request from the Contracting Officer.
5. The bond shall be signed by authorized persons. Where such persons are signing in a representative capacity (e.g., an attorney-in-fact), but is not a member of the firm, partnership, or joint venture, or an officer of the corporation involved, evidence of authority must be furnished.

2. What percent of the total value of this contract do you intend to subcontract? _____ %

3. Do you propose to purchase any equipment for use on this project?
[] No [] Yes If YES, describe type, quantity, and approximate cost:

4. Do you propose to rent any equipment for this work?
[] No [] Yes If YES, describe type and quantity:

5. Is your bid based on firm offers for all materials necessary for this project?
[] Yes [] No If NO, please explain:

C. EXPERIENCE

1. Have you had previous construction contracts or subcontracts with the Authority?
[] Yes [] No

Describe the most recent or current contract, its completion date, and scope of work:

2. List, as an attachment to this questionnaire, other construction projects you have completed, the dates of completion, scope of work, and total contract amount for each project completed in the past 12 months.

I hereby certify that the above statements are true and complete.

Name of Contractor

Name and Title of Person Signing

Signature

Date

ALASKA ENERGY AUTHORITY
SECTION 00 70 00
GENERAL CONDITIONS

- ARTICLE 1 DEFINITIONS
- ARTICLE 2 AUTHORIZATION AND LIMITATIONS
- 2.1 Authorities and Limitations
- 2.2 Evaluations by Contracting Officer
- 2.3 Means and Methods
- 2.4 Visits to Site
- ARTICLE 3 CONTRACT DOCUMENTS: INTENT, AMENDING, REUSE
- 3.1 Incomplete Contract Documents
- 3.2 Copies of Contract Documents
- 3.3 Scope of Work
- 3.4 Intent of Contract Documents
- 3.5 Discrepancy in Contract Documents
- 3.6 Clarifications and Interpretations
- 3.7 Reuse of Documents
- ARTICLE 4 LANDS AND PHYSICAL CONDITIONS
- 4.1 Availability of Lands
- 4.2 Visit to Site
- 4.3 Explorations and Reports
- 4.4 Utilities
- 4.5 Damaged Utilities
- 4.6 Utilities Not Shown or Indicated
- 4.7 Survey Control
- ARTICLE 5 BONDS AND INSURANCE, AND INDEMNIFICATION
- 5.1 Delivery of Bonds
- 5.2 Bonds
- 5.3 Replacement of Bond and Surety
- 5.4 Insurance Requirements
- 5.5 Indemnification
- ARTICLE 6 CONTRACTOR'S RESPONSIBILITIES
- 6.1 Supervision of Work
- 6.2 Superintendence by CONTRACTOR
- 6.3 Character of Workers
- 6.4 CONTRACTOR to Furnish
- 6.5 Materials and Equipment
- 6.6 Anticipated Schedules
- 6.7 Finalizing Schedules
- 6.8 Adjusting Schedules
- 6.9 Substitutes or "Or-Equal" Items
- 6.10 Substitute Means and Methods
- 6.11 Evaluation of Substitution
- 6.12 Dividing the Work
- 6.13 Subcontractors

- 6.14 Use of Premises
- 6.15 Structural Loading
- 6.16 Record Documents
- 6.17 Safety and Protection
- 6.18 Safety Representative
- 6.19 Emergencies
- 6.20 Shop Drawings and Samples
- 6.21 Shop Drawing and Sample Review
- 6.22 Maintenance during Construction
- 6.23 Continuing the Work
- 6.24 Consent to Assignment
- 6.25 Use of Explosives
- 6.26 CONTRACTOR's Records
- 6.27 Load Restrictions

ARTICLE 7 LAWS AND REGULATIONS

- 7.1 Laws to be observed
- 7.2 Permits, Licenses, and Taxes
- 7.3 Patented Devices, Materials and Processes
- 7.4 Compliance of Specifications and Drawings
- 7.5 Accident Prevention
- 7.6 Sanitary Provisions
- 7.7 Business Registration
- 7.8 Professional Registration and Certification
- 7.9 Local Building Codes
- 7.10 Air Quality Control
- 7.11 Archaeological or Paleontological Discoveries
- 7.12 Applicable Alaska Preferences
- 7.13 Preferential Employment
- 7.14 Wages and Hours of Labor
- 7.15 Overtime Work Hours and Compensation
- 7.16 Covenants against Contingent Fees
- 7.17 Officials Not to Benefit
- 7.18 Personal Liability of Public Officials

ARTICLE 8 OTHER WORK

- 8.1 Related Work at Site
- 8.2 Access, Cutting, and Patching
- 8.3 Defective Work by Others
- 8.4 Coordination

ARTICLE 9 CHANGES

- 9.1 AUTHORITY's Right to Change
- 9.2 Authorization of Changes within the General Scope
- 9.3 Directive
- 9.4 Change Order
- 9.5 Shop Drawing Variations
- 9.6 Changes outside the General Scope; Supplemental Agreement
- 9.7 Unauthorized Work
- 9.8 Notification of Surety
- 9.9 Differing Site Conditions

9.10 Interim Work Authorization

ARTICLE 10 CONTRACT PRICE; COMPUTATION AND CHANGE

- 10.1 Contract Price
- 10.2 Claims for Price Change
- 10.3 Change Order Price Determination
- 10.4 Cost of the Work
- 10.5 Excluded Costs
- 10.6 CONTRACTOR's Fee
- 10.7 Cost Breakdown
- 10.8 Cash Allowances
- 10.9 Unit Price Work
- 10.10 Determinations for Unit Prices

ARTICLE 11 CONTRACT TIME, COMPUTATION AND CHANGE

- 11.1 Commencement of Contract Time; Notice to Proceed
- 11.2 Starting the Work
- 11.3 Computation of Contract Time
- 11.4 Time Change
- 11.5 Extension Due to Delays
- 11.6 Essence of Contract
- 11.7 Reasonable Completion Time
- 11.8 Delay Damages

ARTICLE 12 QUALITY ASSURANCE

- 12.1 Warranty and Guaranty
- 12.2 Access to Work
- 12.3 Tests and Inspections
- 12.4 Uncovering Work
- 12.5 AUTHORITY May Stop the Work
- 12.6 Correction or Removal of Defective Work
- 12.7 One Year Correction Period
- 12.8 Acceptance of Defective Work
- 12.9 AUTHORITY may Correct Defective Work

ARTICLE 13 PAYMENTS TO CONTRACTOR AND COMPLETION

- 13.1 Schedule of Values
- 13.2 Preliminary Payments
- 13.3 Application for Progress Payment
- 13.4 Review of Applications for Progress Payments
- 13.5 Stored Materials and Equipment
- 13.6 CONTRACTOR's Warranty of Title
- 13.7 Withholding of Payments
- 13.8 Retainage
- 13.9 Request for Release of funds
- 13.10 Substantial Completion
- 13.11 Access Following Substantial Completion
- 13.12 Final Inspection
- 13.13 Final Completion and Application for Payment
- 13.14 Final Payment

- 13.15 Final Acceptance
- 13.16 CONTRACTOR's Continuing Obligation
- 13.17 Waiver of Claims by CONTRACTOR
- 13.18 No Waiver of Legal Rights

ARTICLE 14 SUSPENSION OF WORK AND TERMINATION

- 14.1 AUTHORITY May Suspend Work
- 14.2 Default of Contract
- 14.3 Rights or Remedies
- 14.4 Convenience Termination

ARTICLE 15 CLAIMS AND DISPUTES

- 15.1 Notification
- 15.2 Presenting Claim
- 15.3 Claim Validity, Additional Information & Authority's Action
- 15.4 Contracting Officer's Decision
- 15.5 Appeals on a Contract Claim
- 15.6 Construction Contract Claim Appeal
- 15.7 Fraud and Misrepresentation in Making a Claim

ARTICLE 1 - DEFINITIONS

Wherever used in the Contract Documents the following terms, or pronouns in place of them, are used, the intent and meaning, unless a different intent or meaning is clearly indicated, shall be interpreted as set forth below.

The titles and headings of the articles, sections, and subsections herein are intended for convenience of reference.

Terms not defined below shall have their ordinary accepted meanings within the context which they are used. Words which have a well-known technical or trade meaning when used to describe work, materials or equipment shall be interpreted in accordance with such meaning. Words defined in Article 1 are to be interpreted as defined.

Addenda - All clarifications, corrections, or changes issued graphically or in writing by the AUTHORITY after the Advertisement but prior to the opening of Proposals.

Advertisement - The public announcement, as required by law, inviting bids for Work to be performed or materials to be furnished.

Application for Payment - The form provided by the AUTHORITY which is to be used by the CONTRACTOR in requesting progress or final payments and which is to include such supporting documentation as is required by the Contract Documents.

Approved or Approval - Means written approval by the Contracting Officer or his authorized representative as defined in Article 2.1. 'Approved' or 'Approval' as used in this contract document shall mean that the Authority has received a document, form or submittal from the Contractor and that the Authority has taken "No exceptions" to the item submitted. Unless the context clearly indicates otherwise, approved or approval shall not mean that the Authority approves of the methods or means, or that the item or form submitted meets the requirements of the contract or constitutes acceptance of the Contractor's work. Where approved or approval means acceptance, then such approval must be set forth in writing and signed by the contracting officer or his designee.

A.S - Initials which stand for Alaska Statute.

Authority - The Alaska Energy Authority (AEA). References to "Contracting Agency" means the AUTHORITY. The AUTHORITY is acting as an agent for Owner.

Award - The acceptance, by the AUTHORITY, of the successful bid.

Bid Bond - A type of Proposal Guaranty.

Bidder - Any individual, firm, corporation or any acceptable combination thereof, or joint venture submitting a bid for the advertised Work.

Calendar Day - Every day shown on the calendar, beginning and ending at midnight.

Change Order - A written order by the AUTHORITY directing changes to the Contract Documents, within their general scope.

Consultant - The person, firm, or corporation retained directly by the AUTHORITY to prepare Contract Documents, perform construction administration services, or other Project related services. References to Authority's Consultants shall include Engineer.

Contingent Sum Work Item - When the bid schedule contains a Contingent Sum Work Item, the Work covered shall be performed only upon the written Directive of the Project Manager. Payment shall be made as provided in the Directive.

Contract - The written agreement between the AUTHORITY and the CONTRACTOR setting forth the obligations of the parties and covering the Work to be performed, all as required by the Contract Documents.

Contract Documents - The Contract form, Addenda, the bidding requirements and CONTRACTOR's bid (including all appropriate bid tender forms), the bonds, the Conditions of the Contract and all other Contract requirements, the Specifications, and the Drawings furnished by the AUTHORITY to the CONTRACTOR, together with all Change Orders and documents approved by the Contracting Officer, for inclusion, modifications and supplements issued on or after the Effective Date of the Contract.

Contracting Officer - The person authorized by the Executive Director to enter into and administer the Contract on behalf of the AUTHORITY; who has authority to make findings, determinations and decisions with respect to the Contract and, when necessary, to modify or terminate the Contract. The Contracting Officer is identified on the construction Contract.

Contractor - The individual, firm, corporation or any acceptable combination thereof, contracts with the AUTHORITY for performance of the Work.

Contract Price - The total moneys payable by the AUTHORITY to the CONTRACTOR under the terms of the Contract Documents.

CONTRACTOR's Release – CONTRACTOR's written notification to the AUTHORITY specifying final payment due and releasing the AUTHORITY of any and all claims.

Contract Time - The number of Calendar Days following issuance of Notice-to-Proceed in which the project shall be rendered Substantially Complete, or if specified as a calendar date, the Substantial Completion date specified in the Contract Documents.

Controlling Item - Any feature of the Work on the critical path of a network schedule.

Defective - Work that is unsatisfactory, faulty or deficient, or does not conform to the Contract Documents.

Directive - A written communication to the CONTRACTOR from the Contracting Officer interpreting or enforcing a Contract requirement or ordering commencement of an item of Work.

Drawings - The Drawings which show the character and scope of the Work to be performed and which have been furnished by the AUTHORITY and are by reference made a part of the Contract Documents.

Engineer - The person, firm, or corporation retained directly by the AUTHORITY to prepare Contract Documents, perform construction administration services, or other Project related services.

Equipment - All machinery together with the necessary supplies for upkeep and maintenance, and also tools and apparatus necessary for the proper construction and acceptable completion of the work.

Final Completion - The Project has progressed to the point that all required Work is complete..

Furnish - To procure, transport, and deliver to the project site materials, labor, or equipment, for installation or use on the project.

General Requirements - Sections of Division 1 of the Specifications which contain administrative and procedural requirements as well as requirements for temporary facilities which apply to Specification Divisions 2 through 16.

Holidays - In the State of Alaska, Legal Holidays occur on:

1. New Years Day - January 1
2. Martin Luther King's Birthday - Third Monday in January
3. President's Day - Third Monday in February
4. Seward's Day - Last Monday in March
5. Memorial Day - Last Monday in May
6. Independence Day - July 4
7. Labor Day - First Monday in September
8. Alaska Day - October 18
9. Veteran's Day - November 11
10. Thanksgiving Day - Fourth Thursday in November
11. Christmas Day - December 25
12. Every Sunday
13. Every day designated by public proclamation by the President of the United States or the Governor of the State as a legal Holiday.

If any Holiday listed above falls on a Saturday, Saturday and the preceding Friday are both legal Holidays. If the Holiday should fall on a Sunday, except (12) above, Sunday and the following Monday are both legal Holidays. See Title 44, Alaska Statutes.

Install - Means to build into the Work, ready to be used in complete and operable condition and in compliance with Contract Documents.

Interim Work Authorization - A written order by the Project Manager initiating changes to the Contract within its general scope, until a subsequent Change Order is executed.

Invitation for Bids - A portion of the bidding documents soliciting bids for the Work to be performed.

Materials - Any substances specified for use in the construction of the project.

Notice of Intent to Award - The written notice by the AUTHORITY to all Bidders identifying the apparent successful Bidder and establishing the AUTHORITY's intent to execute the Contract when all conditions required for execution of the Contract are met.

Notice to Proceed - A written notice to the CONTRACTOR to begin the Work and establishing the date on which the Contract Time begins.

Onsite Project Representative - The Engineer's authorized representative assigned to make detailed observations relating to contract performance.

Owner – Means Grantee for whom the ALASKA ENERGY AUTHORITY is acting as an agent of.

Payment Bond - The security furnished by the CONTRACTOR and his Surety to guarantee payment of the debts covered by the bond.

Performance Bond - The security furnished by the CONTRACTOR and his Surety to guarantee performance and completion of the Work in accordance with the Contract.

Pre-construction Conference - A meeting between the CONTRACTOR, Project Manager and the Engineer, and other parties affected by the construction, to discuss the project before the CONTRACTOR begins work.

Project Manager - The authorized representative of the Contracting Officer who is responsible for administration of the Contract.

Procurement Manager/Officer - The person authorized by the Contracting Officer to administer the Contract on behalf of the AUTHORITY; who has authority to make findings, determinations and decisions with respect to the Contract and, when necessary present such to the Contracting Officer, to modify or terminate the Contract.

Project - The total construction, of which the Work performed under the Contract Documents, is the whole or a part, where such total construction may be performed by more than one CONTRACTOR.

Proposal - The offer of a Bidder, on the prescribed forms, to perform the Work at the prices quoted.

Proposal Guaranty - The security furnished with a Proposal to guarantee that the bidder will enter into a Contract if his Proposal is accepted by the AUTHORITY.

Quality Assurance (QA) - Where referred to in the technical specifications (Divisions 2 through 16), Quality Assurance refers to measures to be provided by the CONTRACTOR as specified.

Quality Control (QC) - Tests and inspections by the CONTRACTOR to insure the acceptability of materials incorporated into the work. QC test reports are used as a basis upon which to determine whether the Work conforms to the requirements of the Contract Documents and to determine its acceptability for payment.

Regulatory Requirements - Laws, rules, regulations, ordinances, codes and/or orders.

Schedule of Values - Document submitted by the CONTRACTOR and reviewed by the Contracting Officer, which shall serve as the basis for computing payment and for establishing the value of separate items of Work which comprise the Contract Price.

Shop Drawings - All drawings, diagrams, illustrations, schedules and other data which are specifically prepared by or for the CONTRACTOR to illustrate some portion of the Work and all illustrations, brochures, standard schedules, performance charts, instructions, diagrams and other information prepared by a Supplier and submitted by the CONTRACTOR to illustrate material, equipment, fabrication, or erection for some portion of the Work. Where used in the Contract Documents, "Shop Drawings" shall also mean "Submittals".

Specifications - Those portions of the Contract Documents consisting of written technical descriptions of materials, equipment, construction systems, standards and workmanship as applied to the Work and certain administrative and procedural details applicable thereto.

Subcontractor - An individual, firm, or corporation to whom the CONTRACTOR or any other Subcontractor sublets part of the Contract.

Substantial Completion - Although not fully completed, the Work (or a specified part thereof) has progressed to the point where it is sufficiently complete, in accordance with the Contract Documents, so that the Work (or specified part) can be utilized for the purposes for which it is intended. The terms "Substantially Complete" and "Substantially Completed" as applied to any Work refer to Substantial Completion thereof.

Supplemental Agreement - A written agreement between the CONTRACTOR and the AUTHORITY covering work that is not within the general scope of the Contract.

Supplementary Conditions - The part of the Contract Documents which amends or supplements these General Conditions.

Supplier - A manufacturer, fabricator, distributor, material man, or vendor of materials or equipment.

Surety - The corporation, partnership, or individual, other than the CONTRACTOR, executing a bond furnished by the CONTRACTOR.

Unit Price Work - Work to be paid for on the basis of unit prices.

Utility - The privately, publicly or cooperatively owned lines, facilities and systems for producing, transmitting or distributing communications, power, electricity, light, heat, gas, oil, crude products, water, steam, waste, storm water not connected with highway or street drainage, and other similar commodities, including publicly owned fire and police signal systems, street lighting systems, and railroads which directly or indirectly serve the public or any part thereof. The term "utility" shall also mean the utility company, inclusive of any wholly owned or controlled subsidiary."

Work - Work is the act of, and the result of, performing services, furnishing labor, furnishing and incorporating materials and equipment into the Project and performing other duties and obligations, all as required by the Contract Documents. Such Work, however incremental, will culminate in the entire completed Project, or the various separately identifiable parts thereof.

ARTICLE 2 – AUTHORIZATION AND LIMITATIONS

2.1 Authorities and Limitations

- 2.1.1 The Contracting Officer alone shall have the power to bind the AUTHORITY and to exercise the rights, responsibilities, authorities and functions vested in the Contracting Officer by the Contract Documents. The Contracting Officer shall have the right to designate in writing authorized representatives to act for him. Wherever any provision of the Contract Documents specifies an individual or organization, whether governmental or private, to perform any act on behalf of or in the interest of the AUTHORITY that individual or organization shall be deemed to be the Contracting Officer's authorized representative under this Contract but only to the extent so specified.
- 2.1.2 The CONTRACTOR shall perform the Work in accordance with any written order (including but not limited to instruction, direction, interpretation or determination) issued by an authorized representative in accordance with the authorized representative's authority to act for the Contracting Officer. The CONTRACTOR assumes all the risk and consequences of performing the Work in accordance with any order (including but not limited to instruction, direction, interpretation or determination) of anyone not authorized to issue such order, and of any order not in writing.
- 2.1.3 The performance or nonperformance of the Contracting Officer or his authorized representative, shall not give rise to any contractual obligation or duty to the CONTRACTOR, any Subcontractor, any Supplier, or any other organization performing any of the Work or any Surety representing them.

2.2 Evaluations by Contracting Officer:

- 2.2.1 The Contracting Officer or his authorized representative will decide all questions which may arise as to:
- a. Quality and acceptability of materials furnished;
 - b. Quality and acceptability of Work performed;
 - c. Compliance with the schedule of progress;
 - d. Interpretation of Contract Documents;
 - e. Acceptable fulfillment of the Contract on the part of the CONTRACTOR.
- 2.2.2 In order to avoid cumbersome terms and confusing repetition of expressions in the Contract Documents the terms "as ordered", "as directed", "as required", "as approved" or terms of like effect or import are used, or the adjectives "reasonable", "suitable", "acceptable", "proper" or "satisfactory" or adjectives of like effect or import are used it shall be understood as if the expression were followed by the words "the Contracting Officer".

When such terms are used to describe a requirement, direction, review or judgment of the Contracting Officer as to the Work, it is intended that such requirement, direction, review or judgment will be solely to evaluate the Work for compliance with the Contract Documents (unless there is a specific statement indicating otherwise).

- 2.2.3 The use of any such term or adjective shall not be effective to assign to the AUTHORITY any duty of authority to supervise or direct the furnishing or performance of the Work or any duty or authority to undertake responsibility contrary to the provisions of paragraphs 2.3 or 2.4.

2.3 Means & Methods:

The means, methods, techniques, sequences or procedures of construction, or safety precautions and the program incident thereto, and the failure to perform or furnish the Work in accordance with the Contract Documents are the sole responsibility of the CONTRACTOR.

2.4 Visits to Site/Place of Business:

The Contracting Officer will make visits to the site and approved remote storage sites at intervals appropriate to the various stages of construction to observe the progress and quality of the executed Work and to determine, in general, if the Work is proceeding in accordance with the Contract Documents. The Contracting Officer may, at reasonable times, inspect that part of the plant or place of business of the CONTRACTOR or Subcontractor that is related to the performance of the Contract. Such observations or the lack of such observations shall in no way relieve the CONTRACTOR from his duty to perform the Work in accordance with the Contract Documents.

ARTICLE 3 - CONTRACT DOCUMENTS: INTENT, AMENDING, REUSE

3.1 Incomplete Contract Documents:

The submission of a bid by the Bidder is considered a representation that the Bidder examined the Contract Documents to make certain that all sheets and pages were provided and that the Bidder is satisfied as to the conditions to be encountered in performing the Work. The AUTHORITY expressly denies any responsibility or liability for a bid submitted on the basis of an incomplete set of Contract Documents.

3.2 Copies of Contract Documents:

The AUTHORITY shall furnish to the CONTRACTOR up to six copies of the Contract Documents. Additional copies will be furnished, upon request, at the cost of reproduction.

3.3 Scope of Work:

The Contract Documents comprise the entire Contract between the AUTHORITY and the CONTRACTOR concerning the Work. The Contract Documents are complementary; what is called for by one is as binding as if called for by all. The Contract Documents will be construed in accordance with the Regulatory Requirements of the place of the Project.

It is specifically agreed between the parties executing this Contract that it is not intended by any of the provisions of the Contract to create in the public or any member thereof a third party benefit, or to authorize anyone not a party to this Contract to maintain a suit pursuant to the terms or provisions of the Contract.

3.4 Intent of Contract Documents:

- 3.4.1 It is the intent of the Contract Documents to describe a functionally complete Project to be constructed in accordance with the Contract Documents. Any Work, materials or equipment that may reasonably be inferred from the Contract Documents as being required to produce the

intended result will be supplied, without any adjustment in Contract Price or Contract Time, whether or not specifically called for.

- 3.4.2 Reference to standard specifications, manuals or codes of any technical society, organization or association, or to the Regulatory Requirements of any governmental authority, whether such reference be specific or by implication, shall mean the edition stated in the Contract Documents or if not stated the latest standard specification, manual, code or Regulatory Requirements in effect at the time of Advertisement for the Project (or, on the Effective Date of the Contract if there was no Advertisement). However, no provision of any referenced standard specification, manual or code (whether or not specifically incorporated by reference in the Contract Documents) shall be effective to change the duties and responsibilities of the AUTHORITY and the CONTRACTOR, or any of their consultants, agents or employees from those set forth in the Contract Documents, nor shall it be effective to assign to the AUTHORITY or any of the AUTHORITY's Consultants, agents or employees, any duty or authority to supervise or direct the furnishing or performance of the Work or any duty or authority to undertake responsibility contrary to the provisions of paragraphs 2.3.

3.5 Discrepancy in Contract Documents:

- 3.5.1 Before undertaking the Work, the CONTRACTOR shall carefully study and compare the Contract Documents and check and verify pertinent figures, and dimensions shown thereon and all applicable field measurements. Work in the area by the CONTRACTOR shall imply verification of figures, dimensions and field measurements. If, during the above study or during the performance of the Work, the CONTRACTOR finds a conflict, error, discrepancy or omission in the Contract Documents, or a discrepancy between the Contract Documents and any standard specification, manual, code, or Regulatory Requirement which affects the Work, the CONTRACTOR shall promptly report such discrepancy in writing to the Contracting Officer. The CONTRACTOR shall obtain a written interpretation or clarification from the Contracting Officer before proceeding with any Work affected thereby. Any adjustment made by the CONTRACTOR without this determination shall be at his own risk and expense. However, the CONTRACTOR shall not be liable to the AUTHORITY for failure to report any conflict, error or discrepancy in the Contract Documents unless the CONTRACTOR had actual knowledge thereof or should reasonably have known thereof.

3.5.2 Discrepancy - Order of Precedence:

When conflicts errors or discrepancies within the Contract Documents exist, the order of precedence from most governing to least governing will be as follows:

- Contents of Addenda
- Supplementary Conditions
- General Conditions
- General Requirements
- Technical Specifications
- Drawings
- Recorded dimensions will govern over scaled dimensions
- Large scale details over small scale details
- Schedules over plans
- Architectural drawings over structural drawings Structural drawings over mechanical and electrical drawings

3.6 Clarifications and Interpretations:

The Contracting Officer will issue with reasonable promptness such written clarifications or interpretations of the requirements of the Contract Documents as the Contracting Officer may determine necessary, which shall be consistent with or reasonably inferable from the overall intent of the Contract Documents.

3.7 Reuse of Documents:

Neither the CONTRACTOR nor any Subcontractor, or Supplier or other person or organization performing or furnishing any of the Work under a direct or indirect contract with the AUTHORITY shall have or acquire any title to or ownership rights in any of the Contract Documents (or copies thereof) prepared by or for the AUTHORITY and they shall not reuse any of the Contract Documents on extensions of the Project or any other project without written consent of the Contracting Officer.

Contract Documents prepared by the CONTRACTOR in connection with the Work shall become the property of the AUTHORITY.

ARTICLE 4 - LANDS AND PHYSICAL CONDITIONS

4.1 Availability of Lands:

The AUTHORITY shall furnish as indicated in the Contract Documents, the lands upon which the Work is to be performed, rights-of-way and easements for access thereto, and such other lands which are designated for use of the CONTRACTOR in connection with the Work. Easements for permanent structures or permanent changes in existing facilities will be obtained and paid for by the AUTHORITY, unless otherwise provided in the Contract Documents. The CONTRACTOR shall provide for all additional lands and access thereto that may be required for temporary construction facilities or storage of materials and equipment. The CONTRACTOR shall provide all waste and disposal areas, including disposal areas for hazardous or contaminated materials, at no additional cost to the AUTHORITY.

4.2 Visit to Site:

The submission of a bid by the CONTRACTOR is considered a representation that the CONTRACTOR has visited and carefully examined the site and is satisfied as to the conditions to be encountered in performing the Work and as to the requirements of the Contract Documents.

4.3 Explorations and Reports:

Reference is made to the Supplementary Conditions for identification of those reports of explorations and tests of subsurface conditions at the site that have been utilized by the AUTHORITY in preparation of the Contract Documents. The CONTRACTOR may for his purposes rely upon the accuracy of the factual data contained in such reports, but not upon interpretations or opinions drawn from such factual data contained therein or for the completeness or sufficiency thereof. Except as indicated in the immediately preceding sentence and in paragraphs 4.4 and 9.9, CONTRACTOR shall have full responsibility with respect to surface and subsurface conditions at the site.

4.4 Utilities:

- 4.4.1 The horizontal and vertical locations of known underground utilities as shown or indicated by the Contract Documents are approximate and are based on information and data furnished to the AUTHORITY by the owners of such underground utilities.
- 4.4.2 The CONTRACTOR shall have full responsibility for:
 - a. Reviewing and checking all information and data concerning utilities.
 - b. Locating all underground utilities shown or indicated in the Contract Documents which are affected by the Work.
 - c. Coordination of the Work with the owners of all utilities during construction.
 - d. Safety and protection of all utilities as provided in paragraph 6.17.
 - e. Repair of any damage to utilities resulting from the Work in accordance with 4.4.4 and 4.5.
- 4.4.3 If Work is to be performed by any utility owner, the CONTRACTOR shall cooperate with such owners to facilitate the Work.
- 4.4.4 In the event of interruption to any utility service as a result of accidental breakage or as result of being exposed or unsupported, the CONTRACTOR shall promptly notify the utility owner and the Project Manager. If service is interrupted, repair work shall be continuous until the service is restored. No Work shall be undertaken around fire hydrants until provisions for continued service has been approved by the local fire authority.

4.5 Damaged Utilities:

When utilities are damaged by the CONTRACTOR, the utility owner shall have the choice of repairing the utility or having the CONTRACTOR repair the utility. In the following circumstances, the CONTRACTOR shall reimburse the utility owner for repair costs or provide at no cost to the utility owner or the AUTHORITY, all materials, equipment and labor necessary to complete repair of the damage:

- a. When the utility is shown or indicated in the Contract Documents.
- b. When the utility has been located by the utility owner.
- c. When no locate was requested by the CONTRACTOR for utilities shown or indicated in the Contract Documents.
- d. All visible utilities.
- e. When the CONTRACTOR could have, otherwise, reasonably been expected to be aware of such utility.

4.6 Utilities Not Shown or Indicated:

If, while directly performing the Work, an underground utility is uncovered or revealed at the site which was not shown or indicated in the Contract Documents and which the CONTRACTOR could not reasonably have been expected to be aware of, the CONTRACTOR shall, promptly after

becoming aware thereof and before performing any Work affected thereby (except in an emergency as permitted by paragraph 6.19) identify the owner of such underground utility and give written notice thereof to that owner and to the Project Manager. The Project Manager will promptly review the underground utility to determine the extent to which the Contract Documents and the Work should be modified to reflect the impacts of the discovered utility. The Contract Documents will be amended or supplemented in accordance with paragraph 9.2 and to the extent necessary through the issuance of a change document by the Contracting Officer. During such time, the CONTRACTOR shall be responsible for the safety and protection of such underground utility as provided in paragraph 6.17. The CONTRACTOR may be allowed an increase in the Contract Price or an extension of the Contract Time, or both, to the extent that they are directly attributable to the existence of any underground utility that was not shown or indicated in the Contract Documents and which the CONTRACTOR could not reasonably have been expected to be aware of.

4.7 Survey Control:

The AUTHORITY will identify sufficient horizontal and vertical control data to enable the CONTRACTOR to survey and layout the Work. All survey work shall be performed under the direct supervision of a registered land surveyor when required by paragraph 7.8. Copies of all survey notes shall be provided to the AUTHORITY at an interval determined by the Project Manager. The Project Manager may request submission on a weekly or longer period at his discretion. Any variations between the Contract Documents and actual field conditions shall be identified in the survey notes. Survey notes are to be in a format acceptable to the AUTHORITY.

ARTICLE 5 - BONDS, INSURANCE, AND INDEMNIFICATION

5.1 Delivery of Bonds:

When the CONTRACTOR delivers the executed Contract to the Contracting Officer, the CONTRACTOR shall also deliver to the Contracting Officer such bonds as the CONTRACTOR may be required to furnish in accordance with paragraph 5.2.

5.2 Bonds:

5.2.1 The CONTRACTOR shall furnish Performance and Payment Bonds, each in an amount as shown on the Contract as security for the faithful performance and payment of all CONTRACTOR's obligations under the Contract Documents. These bonds shall remain in effect for one year after the date of Final Acceptance and until all obligations under this Contract, except special guarantees as per 12.7, have been met. All bonds shall be furnished on forms provided by the AUTHORITY (or copies thereof) and shall be executed by such Sureties as are authorized to do business in the State of Alaska. The Contracting Officer may at his option copy the Surety with notice of any potential default or liability.

5.3 Replacement of Bond and Surety:

If the Surety on any bond furnished in connection with this Contract is declared bankrupt or becomes insolvent or its right to do business is terminated in any state where any part of the Project is located or it ceases to meet the requirements of paragraph 5.2, or otherwise becomes unacceptable to the AUTHORITY, or if any such Surety fails to furnish reports as to his financial condition as requested by the AUTHORITY, the CONTRACTOR shall within five days thereafter substitute another bond and Surety, both of which must be acceptable to AUTHORITY.

An individual Surety may be replaced by a corporate Surety during the course of the Contract period. If the Surety desires to dispose of the collateral posted, the AUTHORITY may, at its option, accept substitute collateral.

5.4 Insurance Requirements:

5.4.1 The CONTRACTOR shall provide evidence of insurance with a carrier or carriers satisfactory to the AUTHORITY covering injury to persons and/or property suffered by the Alaska Energy Authority or a third party, as a result of operations which arise both out of and during the course of this Contract by the CONTRACTOR or by any Subcontractor. This coverage will also provide protection against injuries to all employees of the CONTRACTOR and the employees of any Subcontractor engaged in Work under this Contract.

5.4.2 The CONTRACTOR shall maintain in force at all times during the performance of Work under this agreement the following policies and minimum limits of liability. Where specific limits and coverages are shown, it is understood that they shall be the minimum acceptable. The requirements of this paragraph shall not limit the CONTRACTOR's responsibility to indemnify under paragraph 5.5. Additional insurance requirements specific to this Contract are contained in the Supplementary Conditions, when applicable.

a. Workers' Compensation Insurance: The Contractor shall provide and maintain, for all employees of the Contractor engaged in work under this contract, Workers' Compensation Insurance as required by AS 23.30.045. The Contractor shall be responsible for Workers' Compensation Insurance for any subcontractor who provides services under this contract, to include:

1. Waiver of subrogation against the Authority and Employer's Liability Protection in the amount of \$500,000 each accident/\$500,000 each disease.
2. If the Contractor directly utilizes labor outside of the State of Alaska in the prosecution of the work, "Other States" endorsement shall be required as a condition of the contract.
3. Whenever the work involves activity on or about navigable waters, the Workers' Compensation policy shall contain a United States Longshoreman's and Harbor Worker's Act endorsement, and when appropriate, a Maritime Employer's Liability (Jones Act) endorsement with a minimum limit of \$1,000,000.

b. Commercial General Liability Insurance: on an occurrence policy form covering all operations by or on behalf of the CONTRACTOR with combined single limits not less than:

1. If the CONTRACTOR carries a *Comprehensive General Liability* policy, the limits of liability shall not be less than a Combined Single Limit for bodily injury, property damage and Personal Injury Liability of:
\$1,000,000 each occurrence
\$2,000,000 aggregate
2. If the CONTRACTOR carries a *Commercial General Liability* policy, the limits of liability shall not be less than:
\$1,000,000 each occurrence (Combined Single Limit for bodily injury and property damage)

\$1,000,000 for Personal Injury Liability

\$2,000,000 aggregate for Products-Completed Operations

\$2,000,000 general aggregate

The Authority and the Owner shall be named as "Additional Insured" under all liability coverages listed above.

- c. Automobile Liability Insurance: covering all vehicles used by the Contractor in the performance of services under this agreement with combined single limits not less than:

\$1,000,000 each occurrence

- d. Builder's Risk Insurance: Coverage shall be on an "All Risk" completed value basis including "quake and flood" and protect the interests of the AUTHORITY, the CONTRACTOR and Subcontractors at all tiers. Coverage shall include all materials, supplies and equipment that are intended for specific installation in the Project while such materials, supplies and equipment are located at the Project site, in transit from port of arrival to job site, or while temporarily located away from the Project site.

In addition to providing the above coverages the CONTRACTOR shall require that all indemnities obtained from any SUBCONTRACTORS be extended to include the Authority and Owner as an additional named indemnitees. CONTRACTOR shall further require that the Authority and the Owner be named as additional insured on all liability insurance policies maintained by all SUBCONTRACTORS under their contracts with CONTRACTOR, and that an appropriate waiver of subrogation in favor of the Authority be obtained with respect to all other insurance policies.

- e. Other Coverages: As specified in the Supplementary Conditions, if required.

- 5.4.3 a. In addition to providing the above coverages the Contractor shall, in any contract or agreement with subcontractors performing work, require that all indemnities and waivers of subrogation it obtains, and that any stipulation to be named as an additional insured it obtains, also be extended to waive rights of subrogation against the AUTHORITY and the Owner and to add the ALASKA ENERGY AUTHORITY and the Owner as additional named indemnitees and as additional insured.
- b. Evidence of insurance shall be furnished to the AUTHORITY prior to the award of the contract. Such evidence, executed by the carrier's representative and issued to the AUTHORITY, shall consist of a certificate of insurance or the policy declaration page with required endorsements attached thereto which denote the type, amount, class of operations covered, effective (and retroactive) dates, and dates of expiration. Acceptance by the AUTHORITY of deficient evidence does not constitute a waiver of contract requirements.
- c. When a certificate of insurance is furnished, it shall contain the following statement: "This is to certify that the policies described herein comply with all aspects of the insurance requirements of (Project Name and Number)."

5.5 Indemnification:

The CONTRACTOR shall indemnify, save harmless, and defend the AUTHORITY, the

OWNER its agents and its employees from any and all claims, actions, or liabilities for injuries or damages sustained by any person or property arising directly or indirectly from the CONTRACTOR or SUBCONTRACTOR's performance of WORK under this Contract; however, this provision has no effect if, but only if, the sole proximate cause of the injury or damage is the AUTHORITY's negligence.

ARTICLE 6 - CONTRACTOR'S RESPONSIBILITIES

6.1 Supervision of Work:

The CONTRACTOR shall supervise and direct the Work competently and efficiently, devoting such attention thereto and applying such skills and expertise as may be necessary to perform the Work in accordance with the Contract Documents. All Work under this Contract shall be performed in a skillful and workmanlike manner. The CONTRACTOR shall be solely responsible for the means, methods, techniques, sequences and procedures of construction.

6.2 Superintendence by CONTRACTOR:

The CONTRACTOR shall keep on the Work at all times during its progress a competent resident superintendent. The Project Manager shall be advised in writing of the superintendent's name, local address, and telephone number. This written advice is to be kept current until Final Acceptance by the AUTHORITY. The superintendent will be the CONTRACTOR's representative at the site and shall have full authority to act and sign documents on behalf of the CONTRACTOR.

All communications given to the superintendent shall be as binding as if given to the CONTRACTOR. The CONTRACTOR shall cooperate with the Project Manager in every way possible.

6.3 Character of Workers:

The CONTRACTOR shall provide a sufficient number of competent, suitably qualified personnel to survey and lay out the Work and perform construction as required by the Contract Documents. The CONTRACTOR shall at all times maintain good discipline and order at the site. The Project Manager may, in writing, require the CONTRACTOR to remove from the Work any employee the Project Manager deems incompetent, careless, or otherwise detrimental to the progress of the Work, but the Project Manager shall have no duty to exercise this right.

6.4 CONTRACTOR to Furnish:

Unless otherwise specified in the General Requirements, the CONTRACTOR shall furnish and assume full responsibility for all materials, equipment and machinery, tools, appliances, fuel, power, light, heat, telephone, water, sanitary facilities, temporary facilities and all other facilities and incidentals necessary for the furnishing, performance testing, start-up and completion of the Work.

6.5 Materials and Equipment:

All materials and equipment shall be of specified quality and new, except as otherwise provided in the Contract Documents. If required by the Project Manager, the CONTRACTOR shall furnish satisfactory evidence (including reports of required tests) as to the kind and quality of materials and equipment. All materials and equipment shall be applied, installed, connected, erected, used, cleaned, and conditioned in accordance with the instructions of the applicable Supplier except as otherwise provided in the Contract Documents; but no provision of any such instructions will be

effective to assign to the AUTHORITY or any of the AUTHORITY's consultants, agents or employees, any duty or authority to supervise or direct the furnishing or performance of the Work or any duty or authority to undertake responsibility contrary to the provisions of paragraph 2.3.

6.6 Anticipated Schedules:

- 6.6.1 Prior to submitting the CONTRACTOR's first Application for Payment the CONTRACTOR shall submit to the Project Manager for review an anticipated progress schedule indicating the starting and completion dates of the various stages of the Work.
- 6.6.2 Prior to submitting the CONTRACTOR's first Application for Payment, the CONTRACTOR shall submit to the Project Manager for review:

Anticipated schedule of Shop Drawing submissions; and

Anticipated Schedule of Values for all of the Work which will include quantities and prices of items aggregating the Contract Price and will subdivide the Work into component parts in sufficient detail to serve as the basis for progress payments during construction. Such prices will include an appropriate amount of overhead and profit applicable to each item of Work which will be confirmed in writing by the CONTRACTOR at the time of submission.

6.7 Finalizing Schedules:

Prior to processing the first Application for Payment the Project Manager and the CONTRACTOR will finalize schedules required by paragraph 6.6. The finalized progress schedule will be acceptable to the AUTHORITY as providing information related to the orderly progression of the Work to completion within the Contract Time; but such acceptance will neither impose on the AUTHORITY nor relieve the CONTRACTOR from full responsibility for the progress or scheduling of the Work. If accepted, the finalized schedule of Shop Drawing and other required submissions will be acknowledgment by the AUTHORITY as providing a workable arrangement for processing the submissions. If accepted, the finalized Schedule of Values will be acknowledgment by the AUTHORITY as an approximation of anticipated value of Work accomplished over the anticipated Contract Time. Receipt and acceptance of a schedule submitted by the CONTRACTOR shall not be construed to assign responsibility for performance or contingencies to the AUTHORITY or relieve the CONTRACTOR of his responsibility to adjust his forces, equipment, and work schedules as may be necessary to insure completion of the Work within prescribed Contract Time. Should the prosecution of the Work be discontinued for any reason, the CONTRACTOR shall notify the Project Manager at least 24 hours in advance of resuming operations.

6.8 Adjusting Schedules:

Upon substantial changes to the schedule or upon request the CONTRACTOR shall submit to the Project Manager for acceptance (to the extent indicated in paragraph 6.7 and the General Requirements) adjustments in the schedules to reflect the actual present and anticipated progress of the Work.

6.9 Substitutes or "Or-Equal" Items:

- 6.9.1 Whenever materials or equipment are specified or described in the Contract Documents by using the name of a proprietary item or the name of a particular Supplier the naming of the item is intended to establish the type, function and quality required. Unless the name is followed by

words indicating that substitution is limited or not permitted, materials or equipment of other Suppliers may be accepted by the Project Manager only if sufficient information is submitted by the CONTRACTOR which clearly demonstrates to the Project Manager that the material or equipment proposed is equivalent or equal in all aspects to that named. The procedure for review by the Project Manager will include the following as supplemented in the General Requirements.

- 6.9.2 Requests for review of substitute items of material and equipment will not be accepted by the Project Manager from anyone other than the CONTRACTOR.
- 6.9.3 If the CONTRACTOR wishes to furnish or use a substitute item of material or equipment, the CONTRACTOR shall make written application to the Project Manager for Approval thereof, certifying that the proposed substitute will perform adequately the functions and achieve the results called for by the general design, be similar and of equal substance to that specified and be suited to the same use as the specified. The application will state that the evaluation and Approval of the proposed substitute will not delay the CONTRACTOR's timely achievement of Substantial or Final Completion, whether or not acceptance of the substitute for use in the Work will require a change in any of the Contract Documents (or in the provisions of any other direct contract with the AUTHORITY for Work on the Project) to adapt the design to the proposed substitute and whether or not incorporation or use of the substitute in connection with the Work is subject to payment of any license fee or royalty.
- 6.9.4 All variations of the proposed substitute from that specified will be identified in the application and available maintenance, repair and replacement service will be indicated. The application will also contain an itemized estimate of all costs that will result directly or indirectly from acceptance of such substitute, including costs of redesign and claims of other contractors affected by the resulting change, all of which shall be considered by the AUTHORITY in evaluating the proposed substitute. The AUTHORITY may require the CONTRACTOR to furnish at the CONTRACTOR's expense additional data about the proposed substitute. The Project Manager may reject any substitution request which the Project Manager determines is not in the best interest of the OWNER.
- 6.9.5 Substitutions shall be permitted during or after the bid period as allowed and in accordance with Document 00 02 00 - Invitation for Bids, Document 00 70 00 – General Conditions, and Document 01 60 00 – Materials and Equipment.

6.10 Substitute Means and Methods:

If a specific means, method, technique, sequence or procedure of construction is indicated in or required by the Contract Documents, the CONTRACTOR may furnish or utilize a substitute means, method, sequence, technique or procedure of construction acceptable to the Project Manager, if the CONTRACTOR submits sufficient information to allow the Project Manager to determine that the substitute proposed is equivalent to that indicated or required by the Contract Documents. The procedure for review by the Project Manager will be similar to that provided in paragraph 6.9 as applied by the Project Manager and as may be supplemented in the General Requirements.

6.11 Evaluation of Substitution:

The Project Manager will be allowed a reasonable time within which to evaluate each proposed substitute. The Project Manager will be the sole judge of acceptability, and no substitute will be ordered, installed or utilized without the Contracting Officer's prior written Approval which will be evidenced by either a Change Order or a Shop Drawing Approved in accordance with Sections 6.20 and 6.21. The Contracting Officer may require the CONTRACTOR to furnish at the

CONTRACTOR's expense a special performance guarantee or other Surety with respect to any substitute.

6.12 Dividing the Work:

The divisions and sections of the Specifications and the identifications of any Drawings shall not control the CONTRACTOR in dividing the Work among Subcontractors or Suppliers or delineating the Work to be performed by any specific trade.

6.13 Subcontractors:

The CONTRACTOR may utilize the services of appropriately licensed Subcontractors on those parts of the Work which, under normal contracting practices, are performed by Subcontractors, in accordance with the following conditions:

- 6.13.1 The CONTRACTOR shall not award any Work to any Subcontractor without prior written Approval of the Contracting Officer. This Approval will not be given until the CONTRACTOR submits to the Contracting Officer a written statement concerning the proposed award to the Subcontractor which shall contain required Equal Employment Opportunity documents, evidence of insurance whose limits are acceptable to the CONTRACTOR, and an executed copy of the subcontract. All subcontracts shall contain provisions for prompt payment, release of retainage, and interest on late payment amounts and retainage as specified in AS 36.90.210. Contracts between subcontractors, regardless of tier, must also contain these provisions.
- 6.13.2 The CONTRACTOR shall be fully responsible to the AUTHORITY for all acts and omissions of the Subcontractors, Suppliers and other persons and organizations performing or furnishing any of the Work under a direct or indirect contract with CONTRACTOR just as CONTRACTOR is responsible for CONTRACTOR's own acts and omissions.
- 6.13.3 All Work performed for CONTRACTOR by a Subcontractor will be pursuant to an appropriate written agreement between CONTRACTOR and the Subcontractor which specifically binds the Subcontractor to the applicable terms and conditions of the Contract Documents for the benefit of the AUTHORITY and contains waiver provisions as required by paragraph 13.17 and termination provisions as required by Article 14.
- 6.13.4 Nothing in the Contract Documents shall create any contractual relationship between the AUTHORITY and any such Subcontractor, Supplier or other person or organization, nor shall it create any obligation on the part of the AUTHORITY to pay or to see to the payment of any moneys due any such Subcontractor, Supplier or other person or organization except as may otherwise be required by Regulatory Requirements. The AUTHORITY will not undertake to settle any differences between or among the CONTRACTOR, Subcontractors, or Suppliers.
- 6.13.5 The CONTRACTOR and Subcontractors shall coordinate their work and cooperate with other trades so to facilitate general progress of Work. Each trade shall afford other trades every reasonable opportunity for installation of their work and storage of materials. If cooperative work of one trade must be altered due to lack of proper supervision or failure to make proper provisions in time by another trade, such conditions shall be remedied by the CONTRACTOR with no change in Contract Price or Contract Time.

6.13.6 The CONTRACTOR shall include on his own payrolls any person or persons working on this Contract who are not covered by written subcontract, and shall ensure that all Subcontractors include on their payrolls all persons performing Work under the direction of the Subcontractor.

6.14 Use of Premises:

The CONTRACTOR shall confine construction equipment, the storage of materials and equipment and the operations of workers to the Project limits and approved remote storage sites and lands and areas identified in and permitted by Regulatory Requirements, rights-of-way, permits and easements, and shall not unreasonably encumber the premises with construction equipment or other materials or equipment. The CONTRACTOR shall assume full responsibility for any damage to any such land or area, or to the owner or occupant thereof or of any land or areas contiguous thereto, resulting from the performance of the Work. Should any claim be made against the AUTHORITY by any such owner or occupant because of the performance of the Work, the CONTRACTOR shall hold the AUTHORITY harmless.

6.15 Structural Loading:

The CONTRACTOR shall not load nor permit any part of any structure to be loaded in any manner that will endanger the structure, nor shall the CONTRACTOR subject any part of the Work or adjacent property to stresses or pressures that will endanger it.

6.16 Record Documents:

The CONTRACTOR shall maintain in a safe place at the site one record copy of all Drawings, Specifications, Addenda, Directives, Change Orders, Supplemental Agreements, and written interpretations and clarifications (issued pursuant to paragraph 3.6) in good order and annotated to show all changes made during construction. These record documents together with all Approved samples and a counterpart of all Approved Shop Drawings will be available to the Project Manager for reference and copying. Upon completion of the Work, the annotated record documents, samples and Shop Drawings will be delivered to the Project Manager. Record documents shall accurately record variations in the Work which vary from requirements shown or indicated in the Contract Documents.

6.17 Safety and Protection:

The CONTRACTOR alone shall be responsible for initiating, maintaining and supervising all safety precautions and programs in connection with the Work. The CONTRACTOR shall take all necessary precautions for the safety of, and shall provide the necessary protection to prevent damage, injury or loss to:

6.17.1 All employees on the Work and other persons and organizations who may be affected thereby;

6.17.2 All the Work and materials and equipment to be incorporated therein, whether in storage on or off the site; and

6.17.3 Other property at the site or adjacent thereto, including trees, shrubs, lawns, walks, pavements, roadways, structures, and utilities not designated for removal, relocation or replacement in the course of construction.

The CONTRACTOR shall comply with all applicable Regulatory Requirements of any public body having jurisdiction for the safety of persons or property or to protect them from damage, injury or loss; and shall erect and maintain all necessary safeguards for such safety and protection. The

CONTRACTOR shall notify owners of adjacent property and utility owners when prosecution of the Work may affect them, and shall cooperate with them in the protection, removal, relocation and replacement of their property. All damage, injury or loss to any property caused, directly or indirectly, in whole or in part, by the CONTRACTOR, any Subcontractor, Supplier or any other person or organization directly or indirectly employed by any of them to perform or furnish any of the Work or anyone for whose acts any of them may be liable, shall be remedied by the CONTRACTOR with no change in Contract Price or Contract Time except as stated in 4.6, except damage or loss attributable to unforeseeable causes beyond the control of and without the fault or negligence of the CONTRACTOR, including but not restricted to acts of God, of the public enemy or governmental authorities. The CONTRACTOR's duties and responsibilities for the safety and protection of the Work shall continue until Final Acceptance (except as otherwise expressly provided in connection with Substantial Completion).

6.18 Safety Representative:

The CONTRACTOR shall designate a responsible safety representative at the site. This person shall be the CONTRACTOR's superintendent unless otherwise designated in writing by the CONTRACTOR to the Project Manager.

6.19 Emergencies:

In emergencies affecting the safety or protection of persons or the Work or property at the site or adjacent thereto, the CONTRACTOR, without special instruction or authorization from the AUTHORITY, is obligated to act to prevent threatened damage, injury or loss. The CONTRACTOR shall give the Project Manager prompt written notice if the CONTRACTOR believes that any significant changes in the Work or variations from the Contract Documents have been caused thereby. If the AUTHORITY determines that a change in the Contract Documents is required because of the action taken in response to an emergency, a change will be authorized by one of the methods indicated in Paragraph 9.2, as determined appropriate by the Project Manager.

6.20 Shop Drawings and Samples:

- 6.20.1 After checking and verifying all field measurements and after complying with applicable procedures specified in the General Requirements, the CONTRACTOR shall submit to the Project Manager for review and Approval in accordance with the accepted schedule of Shop Drawing submissions the required number of all Shop Drawings, which will bear a stamp or specific written indication that the CONTRACTOR has satisfied CONTRACTOR's responsibilities under the Contract Documents with respect to the review of the submission. All submissions will be identified as the Project Manager may require. The data shown on the Shop Drawings will be complete with respect to quantities, dimensions, specified performance and design criteria, materials and similar data to enable the Project Manager to review the information as required.
- 6.20.2 The CONTRACTOR shall also submit to the Project Manager for review and Approval with such promptness as to cause no delay in Work, all samples required by the Contract Documents. All samples will have been checked by and accompanied by a specific written indication that the CONTRACTOR has satisfied CONTRACTOR's responsibilities under the Contract Documents with respect to the review of the submission and will be identified clearly as to material, Supplier, pertinent data such as catalog numbers and the use for which intended.
- 6.20.3 Before submission of each Shop Drawing or sample the CONTRACTOR shall have determined and verified all quantities, dimensions, specified performance criteria, installation

requirements, materials, catalog numbers and similar data with respect thereto and reviewed or coordinated each Shop Drawing or sample with other Shop Drawings and samples and with the requirements of the Work and the Contract Documents.

6.20.4 At the time of each submission the CONTRACTOR shall give the Project Manager specific written notice of each variation that the Shop Drawings or samples may have from the requirements of the Contract Documents, and, in addition, shall cause a specific notation to be made on each Shop Drawing submitted to the Project Manager for review and Approval of each such variation. All variations of the proposed Shop Drawing from that specified will be identified in the submission and available maintenance, repair and replacement service will be indicated. The submittal will also contain an itemized estimate of all costs that will result directly or indirectly from acceptance of such variation, including costs of redesign and claims of other Contractors affected by the resulting change, all of which shall be considered by the AUTHORITY in evaluating the proposed variation. If the variation may result in a change of Contract Time or Price, or Contract responsibility, and is not minor in nature; the CONTRACTOR must submit a written request for Change Order with the variation to notify the AUTHORITY of his intent. The AUTHORITY may require the CONTRACTOR to furnish at the CONTRACTOR's expense additional data about the proposed variation. The Project Manager may reject any variation request which the Project Manager determines is not in the best interest of the AUTHORITY.

6.21 Shop Drawing and Sample Review:

- 6.21.1 The Project Manager will review with reasonable promptness Shop Drawings and samples, but the Project Manager's review will be only for conformance with the design concept of the Project and for compliance with the information given in the Contract Documents and shall not extend to means, methods, techniques, sequences or procedures of construction (except where a specific means, method, technique, sequence or procedure of construction is indicated in or required by the Contract Documents) or to safety precautions or programs incident thereto. The review of a separate item as such will not indicate acceptance of the assembly in which the item functions. The CONTRACTOR shall make corrections required by the Project Manager and shall return the required number of corrected copies of Shop Drawings and submit as required new samples for review. The CONTRACTOR shall direct specific attention in writing to revisions other than the corrections called for by the Project Manager on previous submittals.
- 6.21.2 The Project Manager's review of Shop Drawings or samples shall not relieve CONTRACTOR from responsibility for any variation from the requirements of the Contract Documents unless the CONTRACTOR has in writing advised the Project Manager of each such variation at the time of submission as required by paragraph 6.20.4. The Contracting Officer if he so determines, may give written Approval of each such variation by Change Order, except that, if the variation is minor and no Change Order has been requested a specific written notation thereof incorporated in or accompanying the Shop Drawing or sample review comments shall suffice as a modification. Approval by the Contracting Officer will not relieve the CONTRACTOR from responsibility for errors or omissions in the Shop Drawings or from responsibility for having complied with the provisions of paragraph 6.20.3.
- 6.21.3 The AUTHORITY shall be responsible for all AUTHORITY review costs resulting from the initial submission and the resubmittal. The CONTRACTOR shall, at the discretion of the AUTHORITY, pay all review costs incurred by the AUTHORITY as a result of any additional re-submittals.

6.21.4 Where a Shop Drawing or sample is required by the Specifications, any related Work performed prior to the Project Manager's review and Approval of the pertinent submission will be the sole expense and responsibility of the CONTRACTOR.

6.22 Maintenance During Construction:

The CONTRACTOR shall maintain the Work during construction and until Substantial Completion, at which time the responsibility for maintenance shall be established in accordance with paragraph 13.10.

6.23 Continuing the Work:

The CONTRACTOR shall carry on the Work and adhere to the progress schedule during all disputes or disagreements with the AUTHORITY. No Work shall be delayed or postponed pending resolution of any disputes, disagreements, or claims except as the CONTRACTOR and the Contracting Officer may otherwise agree in writing.

6.24 Consent to Assignment:

The CONTRACTOR shall obtain the prior written consent of the Contracting Officer to any proposed assignment of any interest in, or part of this Contract. The consent to any assignment or transfer shall not operate to relieve the CONTRACTOR or his Sureties of any of his or its obligations under this Contract or the Performance Bonds. Nothing herein contained shall be construed to hinder, prevent, or affect an assignment of monies due, or to become due hereunder, made for the benefit of the CONTRACTOR's creditors pursuant to law.

6.25 Use of Explosives:

6.25.1 When the use of explosives is necessary for the prosecution of the Work, the CONTRACTOR shall exercise the utmost care not to endanger life or property, including new Work and shall follow all Regulatory Requirements applicable to the use of explosives. The CONTRACTOR shall be responsible for all damage resulting from the use of explosives.

6.25.2 All explosives shall be stored in a secure manner in compliance with all Regulatory Requirements, and all such storage places shall be clearly marked. Where no Regulatory Requirements apply, safe storage shall be provided not closer than 1,000 feet from any building, camping area, or place of human occupancy.

6.25.3 The CONTRACTOR shall notify each public utility owner having structures in proximity to the site of his intention to use explosives. Such notice shall be given sufficiently in advance to enable utility owners to take such steps as they may deem necessary to protect their property from injury. However, the CONTRACTOR shall be responsible for all damage resulting from the use of the explosives, whether or not, utility owners act to protect their property.

6.26 CONTRACTOR's Records:

6.26.1 Records of the CONTRACTOR and Subcontractors relating to personnel, payrolls, invoices of materials, and any and all other data relevant to the performance of this Contract, must be kept on a generally recognized accounting system. Such records must be available during normal work hours to the Contracting Officer for purposes of investigation to ascertain compliance with Regulatory Requirements and provisions of the Contract Documents.

- 6.26.2 Payroll records must contain the name and address of each employee, his correct classification, rate of pay, daily and weekly number of hours of work, deductions made, and actual wages paid. The CONTRACTOR and Subcontractors shall make employment records available for inspection by the Contracting Officer and representatives of the U.S. and/or State Department of Labor and will permit such representatives to interview employees during working hours on the Project.
- 6.26.3 Records of all communications between the AUTHORITY and the CONTRACTOR and other parties, where such communications affected performance of this Contract, must be kept by the CONTRACTOR and maintained for a period of three years from Final Acceptance. The AUTHORITY or its assigned representative may perform an audit of these records during normal work hours after written notice to the CONTRACTOR.

6.27 Load Restrictions

The CONTRACTOR shall comply with all load restrictions as set forth in the "Administrative Permit Manual", and Title 17, Chapter 25, of the Alaska Administrative Code in the hauling of materials on public roads, beyond the limits of the project, and on all public roads within the project limits that are scheduled to remain in use upon completion of the project.

Overload permits may, at the discretion of the State, be issued for travel beyond the project limits for purposes of mobilization and/or demobilization. Issuance of such a permit will not relieve the CONTRACTOR of liability for damage which may result from the moving of equipment.

The operation of equipment of such weight or so loaded as to cause damage to any type of construction will not be permitted. No overloads will be permitted on the base course or surface course under construction. No loads will be permitted on a concrete pavement, base or structure before the expiration of the curing period. The CONTRACTOR shall be responsible for all damage done by his equipment.

ARTICLE 7 - LAWS AND REGULATIONS

7.1 Laws to be Observed

The CONTRACTOR shall keep fully informed of all federal and state Regulatory Requirements and all orders and decrees of bodies or tribunals having any jurisdiction or authority, which in any manner affect those engaged or employed on the Work, or which in any way affect the conduct of the Work. The CONTRACTOR shall at all times observe and comply with all such Regulatory Requirements, orders and decrees; and shall protect and indemnify the AUTHORITY and its representatives against claim or liability arising from or based on the violation of any such Regulatory Requirement, order, or decree whether by the CONTRACTOR, Subcontractor, or any employee of either. Except where otherwise expressly required by applicable Regulatory Requirements, the AUTHORITY shall not be responsible for monitoring CONTRACTOR's compliance with any Regulatory Requirements.

7.2 Permits, Licenses, and Taxes

- 7.2.1 The CONTRACTOR shall procure all permits and licenses, pay all charges, fees and taxes, and give all notices necessary and incidental to the due and lawful prosecution of the Work. As a condition of performance of this Contract, the CONTRACTOR shall pay all federal, state and local taxes incurred by the CONTRACTOR, in the performance of this Contract. Proof of

payment of these taxes is a condition precedent to final payment by the AUTHORITY under this Contract.

- 7.2.2 The CONTRACTOR's certification that taxes have been paid (as contained in the *Release of Contract*) will be verified with the Department of Revenue and Department of Labor, prior to final payment.
- 7.2.3 If any federal, state or local tax is imposed, charged, or repealed after the date of bid opening and is made applicable to and paid by the CONTRACTOR on the articles or supplies herein contracted for, then the Contract shall be increased or decreased accordingly by a Change Order.

7.3 Patented Devices, Materials and Processes

If the CONTRACTOR employs any design, device, material, or process covered by letters of patent, trademark or copyright, the CONTRACTOR shall provide for such use by suitable legal agreement with the patentee or owner. The CONTRACTOR and the Surety shall indemnify and save harmless the AUTHORITY, any affected third party, or political subdivision from any and all claims for infringement by reason of the use of any such patented design, device, material or process, or any trademark or copyright, and shall indemnify the AUTHORITY for any costs, expenses, and damages which it may be obliged to pay by reason of any infringement, at any time during the prosecution or after the completion of the Work.

7.4 Compliance of Specifications and Drawings:

If the CONTRACTOR observes that the Specifications and Drawings supplied by the AUTHORITY are at variance with any Regulatory Requirements, CONTRACTOR shall give the Project Manager prompt written notice thereof, and any necessary changes will be authorized by one of the methods indicated in paragraph 9.2. as determined appropriate by the Project Manager. If the CONTRACTOR performs any Work knowing or having reason to know that it is contrary to such Regulatory Requirements, and without such notice to the Project Manager, the CONTRACTOR shall bear all costs arising there from; however, it shall not be the CONTRACTOR's primary responsibility to make certain that the Specifications and Drawings supplied by the AUTHORITY are in accordance with such Regulatory Requirements.

7.5 Accident Prevention:

The CONTRACTOR shall comply with AS 18.60.075 and all pertinent provisions of the Construction Code Occupational Safety and Health Standards issued by the Alaska Department of Labor.

7.6 Sanitary Provisions:

The CONTRACTOR shall provide and maintain in a neat and sanitary condition such accommodations for the use of his employees and AUTHORITY representatives as may be necessary to comply with the requirements of the State and local Boards of Health, or of other bodies or tribunals having jurisdiction.

7.7 Business Registration:

Comply with AS 08.18.011, as follows: "it is unlawful for a person to submit a bid or work as a contractor until he has been issued a certificate of registration by the Department of Commerce. A

partnership or joint venture shall be considered registered if one of the general partners or ventures whose name appears in the name under which the partnership or venture does business is registered."

7.8 Professional Registration and Certification:

All craft trades, architects, engineers and land surveyors, electrical administrators, and explosive handlers employed under the Contract shall specifically comply with applicable provisions of AS 08.18, 08.48, 08.40, and 08.52. Provide copies of individual licenses within seven days following a request from the Contracting Officer.

7.9 Local Building Codes:

The CONTRACTOR shall comply with AS 35.10.025 which requires construction in accordance with applicable local building codes to include the obtaining of required permits.

7.10 Air Quality Control:

The CONTRACTOR shall comply with all applicable provisions of AS 46.03.04 as pertains to Air Pollution Control.

7.11 Archaeological or Paleontological Discoveries:

When the CONTRACTOR's operation encounters prehistoric artifacts, burials, remains of dwelling sites, or paleontological remains, such as shell heaps, land or sea mammal bones or tusks, the CONTRACTOR shall cease operations immediately and notify the Project Manager. No artifacts or specimens shall be further disturbed or removed from the ground and no further operations shall be performed at the site until so directed. Should the Contracting Officer order suspension of the CONTRACTOR's operations in order to protect an archaeological or historical finding, or order the CONTRACTOR to perform extra Work, such shall be covered by an appropriate Contract change document.

7.12 Applicable Alaska Preferences: Not Applicable.

7.13 Preferential Employment: Not Applicable.

7.14 Wages and Hours of Labor:

7.14.1 One certified copy of all payrolls shall be submitted weekly to the State Department of Labor and, upon request, to the Contracting Officer to assure to assure compliance with AS 36.05.040, *Filing Schedule of Employees Wages Paid and Other Information*. The CONTRACTOR shall be responsible for the submission of certified copies of payrolls of all Subcontractors. The certification shall affirm that the payrolls are current and complete, that the wage rates contained therein are not less than the applicable rates referenced in these Contract Documents, and that the classification set forth for each laborer or mechanic conforms to the Work performed. The CONTRACTOR and his Subcontractors shall attend all hearings and conferences and produce such books, papers, and documents all as requested by the Department of Labor. Should federal funds be involved, the appropriate federal agency shall also receive a copy of the CONTRACTOR's certified payrolls. Regardless of project funding source, copies of all certified payrolls supplied to the State Department of Labor by the CONTRACTOR shall be supplied also to the Project Manager upon request, including submittals made by, or on behalf of, subcontractors.

7.14.2 The following labor provisions shall also apply to this Contract:

- a. The CONTRACTOR and his Subcontractors shall pay all employees unconditionally and not less than once a week;
- b. wages may not be less than those stated under AS 36.05.010, regardless of the contractual relationship between the CONTRACTOR or Subcontractors and laborers, mechanics, or field surveyors;
- c. the scale of wages to be paid shall be posted by the CONTRACTOR in a prominent and easily accessible place at the site of the Work;
- d. the AUTHORITY shall withhold so much of the accrued payments as is necessary to pay to laborers, mechanics, or field surveyors employed by the CONTRACTOR or Subcontractors the difference between
 1. the rates of wages required by the Contract to be paid laborers, mechanics, or field surveyors on the Work, and
 2. the rates of wages in fact received by laborers, mechanics or field surveyors.

7.14.3 Within three calendar days of award of a construction contract, the CONTRACTOR shall file a "Notice of Work" with the Department of Labor and shall pay all related fees. The Contracting Officer will not issue Notice to Proceed to the CONTRACTOR until such notice and fees have been paid to the Department of Labor. Failure of the CONTRACTOR to file the Notice of Work and pay fees within this timeframe shall not constitute grounds for an extension of contract time or adjustment of contract price.

7.15 Overtime Work Hours and Compensation:

Pursuant to 40 *U.S.C.* 327-330 and AS 23.10.060 -.110, the CONTRACTOR shall not require nor permit any laborer or mechanic in any workweek in which he is employed on any Work under this Contract to work in excess of eight hours in any Calendar Day or in excess of forty hours in such workweek on Work subject to the provisions of the *Contract Work Hours and Safety Standards Act* unless such laborer or mechanic receives compensation at a rate not less than one and one half times his basic rate of pay for all such hours worked in excess of eight hours in any Calendar Day or in excess of forty hours in such workweek whichever is the greater number of overtime hours. In the event of any violation of this provision, the CONTRACTOR shall be liable to any affected employee for any amounts due and penalties and to the AUTHORITY for liquidated damages. Such liquidated damages shall be computed with respect to each individual laborer or mechanic employed in violation of this provision in the sum of \$10.00 for each Calendar Day on which such employee was required or permitted to be employed on such Work in excess of eight hours or in excess of the standard workweek of forty hours without payment of the overtime wages required by this paragraph.

7.16 Covenant Against Contingent Fees:

The CONTRACTOR warrants that no person or selling agent has been employed or retained to solicit or secure this Contract upon an agreement or understanding for a commission, percentage, brokerage, or contingent fee, excepting bona fide employees or bona fide established commercial or selling agencies maintained by the CONTRACTOR for the purpose of securing business. For breach or violation of this warrant, the AUTHORITY shall have the right to annul this Contract without liability or, in its discretion, to deduct price of consideration from the Contract or otherwise

recover the full amount of such commission, percentage, brokerage, or contingent fee.

7.17 Officials Not to Benefit:

No member of or delegate to the U.S. Congress, the Alaska State Legislature or other state official shall be admitted to any share or part of this Contract, nor to any benefit that may arise there from. However, this provision shall not be construed to extend to this Contract if made with a corporation for its general benefit.

7.18 Personal Liability of Public Officials:

In carrying out any of the provisions thereof, or in exercising any power or authority granted to the Contracting Officer by the Contract, there will be no liability upon the Contracting Officer nor upon AUTHORITY employees authorized as his representatives, either personally or as officials of the AUTHORITY, it being always understood that in such matters they act as agents and representatives of the AUTHORITY.

ARTICLE 8 - OTHER WORK

8.1 Related Work at Site:

8.1.1 The AUTHORITY reserves the right at any time to contract for and perform other or additional work on or near the Work covered by the Contract.

8.1.2 When separate contracts are let within the limits of the Project, the CONTRACTOR shall conduct his Work so as not to interfere with or hinder the work being performed by other contractors. The CONTRACTOR when working on the same Project with other contractors shall cooperate with such other contractors. The CONTRACTOR shall join his Work with that of the others in an acceptable manner and shall perform it in proper sequence to that of others.

8.1.3 If the fact that other such work is to be performed is identified or shown in the Contract Documents the CONTRACTOR shall assume all liability, financial or otherwise, in connection with this Contract and indemnify and save harmless the AUTHORITY from any and all damages or claims that may arise because of inconvenience, delay, or loss experienced by the CONTRACTOR because of the presence and operations of other contractors.

8.1.4 If the fact that such other work is to be performed was not identified or shown in the Contract Documents, written notice thereof will be given to the CONTRACTOR prior to starting any such other work. If the CONTRACTOR believes that such performance will require an increase in Contract Price or Contract Time, the CONTRACTOR shall notify the Project Manager of such required increase within fifteen (15) calendar days following receipt of the Contracting Officer's notice. Should the Project Manager find such increase(s) to be justified, a Change Order will be executed.

8.2 Access, Cutting, and Patching:

The CONTRACTOR shall afford each utility owner and any other contractor who is a party to such a direct contract with the AUTHORITY (or the AUTHORITY, if the AUTHORITY is performing the additional work with the AUTHORITY's employees) proper and safe access to the site and a reasonable opportunity for the introduction and storage of materials and equipment and the execution of such work, and shall properly connect and coordinate the Work with the work of others. The CONTRACTOR shall do all cutting, fitting and patching of the Work that may be required to make its several parts come together properly and integrate with such other work, the CONTRACTOR shall not endanger any work of others by cutting, excavating or otherwise altering

their work and will only cut or alter such other work with the written consent of the Project Manager. The duties and responsibilities of the CONTRACTOR under this paragraph are for the benefit of other contractors to the extent that there are comparable provisions for the benefit of the CONTRACTOR in said direct contracts between the AUTHORITY and other contractors.

8.3 Defective Work by Others:

If any part of the CONTRACTOR's Work depends for proper execution or results upon the work of any such other contractor, utility owner, or the AUTHORITY, the CONTRACTOR shall inspect and promptly report to the Project Manager in writing any delays, defects or deficiencies in such work that render it unavailable or unsuitable for such proper execution and results. The CONTRACTOR's failure to so report will constitute an acceptance of the other work as fit and proper for integration with CONTRACTOR's Work except for latent or non-apparent defects and deficiencies in the other work.

8.4 Coordination:

If the AUTHORITY contracts with others for the performance of other work at the site, Project Manager will have authority and responsibility for coordination of the activities among the various prime contractors.

ARTICLE 9 - CHANGES

9.1 AUTHORITY's Right to Change

Without invalidating the Contract and without notice to any Surety, the AUTHORITY may, at any time or from time to time, order additions, deletions or revisions in the Work within the general scope of the Contract, including but not limited to changes:

- 9.1.1 In the Contract Documents;
- 9.1.2 In the method or manner of performance of the Work;
- 9.1.3 In Authority-furnished facilities, equipment, materials, services, or site;
- 9.1.4 Directing acceleration in the performance of the Work.

9.2 Authorization of Changes within the General Scope.

Additions, deletions, or revisions in the Work within the general scope of the Contract as specified in 9.1 shall be authorized by one or more of following ways:

- 9.2.1 Directive (pursuant to paragraph 9.3)
- 9.2.2 A Change Order (pursuant to paragraph 9.4)
- 9.2.3 AUTHORITY's acceptance of Shop Drawing variations from the Contract Documents as specifically identified by the CONTRACTOR as required by paragraph 6.20.4.

9.3 Directive

- 9.3.1 The Contracting Officer shall provide written clarification or interpretation of the Contract Documents (pursuant to paragraph 3.6).
- 9.3.2 The Project Manager may authorize minor variations in the Work from the requirements of the Contract Documents which do not involve an adjustment in the Contract Price or the Contract Time and are consistent with the overall intent of the Contract Documents.
- 9.3.3 The Project Manager may order the Contractor to correct Defective Work or methods which are not in conformance with the Contract Documents.
- 9.3.4 The Project Manager may direct the commencement or suspension of Work or emergency related Work (as provided in paragraph 6.19).
- 9.3.5 Upon the issuance of a Directive to the CONTRACTOR by the Project Manager, the CONTRACTOR shall proceed with the performance of the Work as prescribed by such Directive.
- 9.3.6 If the CONTRACTOR believes that the changes noted in a Directive may cause an increase in the Contract Price or an extension of Contract Time, the CONTRACTOR shall immediately provide written notice to the Project Manager depicting such increases before proceeding with the Directive, except in the case of an emergency. If the Project Manager finds the increase in Contract Price or the extension of Contract Time justified, a Change Order will be issued. If however, the Project Manager does not find that a Change Order is justified, the Project Manager may direct the CONTRACTOR to proceed with the Work. The CONTRACTOR shall cooperate with the Project Manager in keeping complete daily records of the cost of such Work. If a Change Order is ultimately determined to be justified, in the absence of agreed prices and unit prices, payment for such Work will be made on a "cost of the work basis" as provided in 10.4

9.4 Change Order

A change in Contract Time, Contract Price, or responsibility may be made for changes within the scope of the Work by Change Order. Upon receipt of an executed Change Order, the CONTRACTOR shall promptly proceed with the Work involved which will be performed under the applicable conditions of the Contract Documents except as otherwise specifically provided. Changes in Contract Price and Contract Time shall be made in accordance with Articles 10 and 11. A Change Order shall be considered executed when it is signed by the AUTHORITY.

9.5 Shop Drawing Variations

Variations by shop drawings shall only be eligible for consideration under 9.4 when the conditions affecting the price, time, or responsibility are identified by the CONTRACTOR in writing and a request for a Change Order is submitted as per 6.20.4.

9.6 Changes Outside the General Scope; Supplemental Agreement

Any change which is outside the general scope of the Contract, as determined by the Project Manager, must be authorized by a Supplemental Agreement signed by the appropriate representatives of the AUTHORITY and the CONTRACTOR.

9.7 Unauthorized Work:

The CONTRACTOR shall not be entitled to an increase in the Contract Price or an extension of the Contract Time with respect to any work performed that is not required by the Contract Documents as amended, modified and supplemented as provided in this Article 9, except in the case of an emergency as provided in paragraph 6.19 and except in the case of uncovering Work as provided in paragraph 12.4.2.

9.8 Notification of Surety:

If notice of any change affecting the general scope of the Work or the provisions of the Contract Documents (including, but not limited to, Contract Price or Contract Time) is required by the provisions of any bond to be given to a Surety, the giving of any such notice will be the CONTRACTOR's responsibility, and the amount of each applicable bond will be adjusted accordingly.

9.9 Differing Site Conditions:

9.9.1 The CONTRACTOR shall promptly, and before such conditions are disturbed (except in an emergency as permitted by paragraph 6.19), notify the Project Manager in writing of: (1) subsurface or latent physical conditions at the site differing materially from those indicated in the Contract, and which could not have been discovered by a careful examination of the site, or (2) unknown physical conditions at the site, of an unusual nature, differing materially from those ordinarily encountered and generally recognized as inherent in work of the character provided for in this Contract. The Project Manager shall promptly investigate the conditions, and if the Project Manager finds that such conditions do materially so differ and cause an increase or decrease in the CONTRACTOR's cost of, or time required for, performance of this Contract, an equitable adjustment shall be made and the Contract modified in writing accordingly.

9.9.2 Any claim for additional compensation by the CONTRACTOR under this clause shall be made in accordance with Article 15. In the event that the Contracting Officer and the CONTRACTOR are unable to reach an agreement concerning an alleged differing site condition, the CONTRACTOR will be required to keep an accurate and detailed record which will indicate the actual "cost of the work" done under the alleged differing site condition. Failure to keep such a record shall be a bar to any recovery by reason of such alleged differing site conditions. The Project Manager shall be given the opportunity to supervise and check the keeping of such records.

9.10 Interim Work Authorization

An Interim Work Authorization may be used to establish a change within the scope of the Work; however, only a Change Order shall establish associated changes in Contract Time and Price. Work authorized by Interim Work Authorization shall be converted to a Change Order. The basis of payment shall be as stated in the Interim Work Authorization, unless it states that the basis of payment has not been established and is to be negotiated, in which case the Cost of the Work shall be documented pursuant to Article 10.4, to establish a basis for negotiating a lump sum price for the Change Order.

ARTICLE 10 - CONTRACT PRICE; COMPUTATION AND CHANGE

10.1 Contract Price:

The Contract Price constitutes the total compensation (subject to authorized adjustments) payable to the CONTRACTOR for performing the Work. All duties, responsibilities and obligations assigned to or undertaken by the CONTRACTOR shall be at his expense without change in the Contract Price. The Contract Price may only be changed by a Change Order or Supplemental Agreement.

10.2 Claim for Price Change:

Any claim for an increase or decrease in the Contract Price shall be submitted in accordance with the terms of Article 15, and shall not be allowed unless notice requirements of this Contract have been met.

10.3 Change Order Price Determination:

The value of any Work covered by a Change Order for an increase or decrease in the Contract Price shall be determined in one of the following ways:

10.3.1 Where the Work involved is covered by unit prices contained in the Contract Documents, by application of unit prices to the quantities of the items involved (subject to the provisions of subparagraphs 10.9.1 through 10.9.3, inclusive).

10.3.2 By mutual acceptance of a lump sum price that includes overhead and profit. The following maximum rates of cost markup (to cover both overhead and profit of the CONTRACTOR) shall be used in the negotiation of a Lump Sum Change Order:

- a. 17% - where a cost is borne directly by prime contractor (first tier contractor).
- b. 10% - where a cost is borne by a subcontractor (lower tier contractor).

Where the cost is borne by a subcontractor acting as a first tier contractor, the allowable overhead and profit markup for lump sum change orders shall not exceed 17%. Any lower tier subcontractors, including the CONTRACTOR in this case, for whom the first tier subcontractor performs the work, shall be allowed an overhead and profit markup that does not exceed 10%.

10.3.3 When 10.3.1 and 10.3.2 are inapplicable, on the basis of the "cost of the work" (determined as provided in paragraphs 10.4 and 10.5) plus a CONTRACTOR's fee for overhead and profit (determined as provided in paragraph 10.6).

10.3.4 Before a Change Order or Supplemental Agreement is approved, the CONTRACTOR shall submit cost or pricing data regarding the changed or extra Work. The CONTRACTOR shall certify that the data submitted is, to his best knowledge and belief, accurate, complete and current as of a mutually determined specified date and that such data will continue to be accurate and complete during the performance of the changed or extra Work.

10.4 Cost of the Work:

The term "cost of the work" means the sum of all costs necessarily incurred and paid by the CONTRACTOR in the proper performance of the Work. Except as otherwise may be agreed to in writing by the AUTHORITY, such costs shall be in amount no higher than those prevailing in the locality of the Project, shall include only the following items and shall not include any of the costs itemized in subparagraph 10.5:

- 10.4.1 Payroll costs for employees in the direct employ of the CONTRACTOR in the performance of the Work under schedules of job classifications agreed upon by the AUTHORITY and the CONTRACTOR. Payroll costs for employees not employed full time on the Work shall be apportioned on the basis of their time spent on the Work. Payroll costs shall include, but not be limited to, salaries and wages plus the cost of fringe benefits which shall include social security contributions, unemployment, excise and payroll taxes, workers' or workmen's compensation, health and retirement benefits, bonuses, sick leave, vacation and holiday pay applicable thereto. Such employees shall include manual workers up through the level of foreman but shall not include general foremen, superintendents, and non-manual employees. The expenses of performing Work after regular working hours, on Saturday, Sunday or legal holidays shall be included in the above to the extent authorized by the AUTHORITY.
- 10.4.2 Cost of all materials and equipment furnished and incorporated or consumed in the Work, including costs of transportation and storage thereof, and Suppliers' field services required in connection therewith. All cash discounts shall accrue to the CONTRACTOR unless the AUTHORITY deposits funds with the CONTRACTOR with which to make payments, in which case the cash discounts shall accrue to the AUTHORITY. All trade discounts, rebates and refunds and all returns from sale of surplus materials and equipment shall accrue to the AUTHORITY, and the CONTRACTOR shall make provisions so that they may be obtained.
- 10.4.3 Payments made by the CONTRACTOR to Subcontractors for Work performed by Subcontractors. If required by the AUTHORITY, CONTRACTOR shall obtain competitive quotes from Subcontractors or Suppliers acceptable to the CONTRACTOR and shall deliver such quotes to the AUTHORITY who will then determine which quotes will be accepted. If a subcontract provides that the Subcontractor is to be paid on the basis of "cost of the work" plus a fee, the Subcontractor' "cost of the work" shall be determined in the same manner as the CONTRACTOR's "cost of work" as described in paragraphs 10.4 through 10.5; and the Subcontractor's fee shall be established as provided for under subparagraph 10.6.2 clause b. All subcontracts shall be subject to the other provisions of the Contract Documents insofar as applicable.
- 10.4.4 Costs of special consultants (including but not limited to engineers, architects, testing laboratories, and surveyors) employed for services necessary for the completion of the Work.
- 10.4.5 Supplemental costs including the following:
- a. The proportion of necessary transportation, travel and subsistence expenses of the CONTRACTOR's employees incurred in discharge of duties connected with the Work.
 - b. Cost, including transportation and maintenance, of all materials, supplies, equipment, machinery, appliances, office and temporary facilities at the site and hand tools not owned by the workers, which are consumed in the performance of the Work, and cost less market value of such items used but not consumed which remain the property of the CONTRACTOR.
 - c. Rentals of all construction equipment and machinery and the parts thereof whether rented from the CONTRACTOR or others in accordance with rental agreements Approved by the AUTHORITY and the costs of transportation, loading, unloading, installation, dismantling and removal thereof - all in accordance with terms of said rental agreements. The rental of any such equipment, machinery or parts shall cease when the use thereof is no longer necessary for the Work.

For any machinery or special equipment (other than small tools) which has been authorized by

the Project Manager, the CONTRACTOR shall receive the rental rates in the current edition and appropriate volume of the "Rental Rate Blue Book for Construction Equipment", published by Dataquest, Inc., 1290 Ridder Park Drive, San Jose, CA 95131. Hourly rental rates shall be determined as follows:

The established hourly rental rate shall be equal to the adjusted monthly rate for the basic equipment plus the adjusted monthly rate for applicable attachments, both divided by 176, and multiplied by the area adjustment factor, plus the estimated hourly operating cost.

The adjusted monthly rate is that resulting from application of the rate adjustment formula in order to eliminate replacement cost allowances in machine depreciation and contingency cost allowances.

Attachments shall not be included unless required for the time and materials work.

For equipment not listed in The Blue Book, the CONTRACTOR shall receive a rental rate as agreed upon before such work is begun. If agreement cannot be reached, the AUTHORITY reserves the right to establish a rate based on similar equipment in the Blue Book or prevailing commercial rates in the area.

These rates shall apply for equipment used during the CONTRACTOR's regular shift of 10 hours per day. Where the equipment is used more than 10 hours per day, either on the CONTRACTOR's normal work or on time and materials, and either on single or multiple shifts, an overtime rate, computed as follows, shall apply:

The hourly overtime rate shall be equal to the adjusted monthly rate for the basic equipment plus the adjusted monthly rate for applicable attachments, both divided by 352, and multiplied by the area adjustment factor, plus the estimated hourly operating cost.

Equipment which must be rented or leased specifically for work required under this section shall be authorized in writing by the Project Manager. The CONTRACTOR shall be paid invoice price plus 15%.

When it is necessary to obtain equipment from sources beyond the project limits exclusively for time and materials, work, the actual cost of transferring the equipment to the site of the work and return will be allowed as an additional item of expense. Where the move is made by common carrier, the move-in allowance will be limited to the amount of the freight bill or invoice. If the CONTRACTOR hauls the equipment with his own forces, the allowance will be limited to the rental rate for the hauling unit plus operator wages. In the event that the equipment is transferred under its own power, the moving allowance will be limited to one-half of the normal hourly rental rate plus operator's wages. In the event that the move-out is to a different location, payment will in no instance exceed the amount of the move-in. Move-in allowance shall not be made for equipment brought to the project for time and materials work which is subsequently retained on the project and utilized for completion of contract items, camp maintenance, or related work.

Equipment ordered to be on a stand-by basis shall be paid for at the stand-by rental rate for the number of hours in the CONTRACTOR'S normal work shift, but not to exceed 8 hours per day. The stand-by rental rate shall be computed as follows:

The hourly stand-by rate shall be equal to the adjusted monthly rate for the basic equipment plus the adjusted monthly rate for applicable attachments, both divided by 352, all multiplied by the area adjustment factor.

Time will be recorded to the nearest one-quarter hour for purposes of computing compensation to the CONTRACTOR for equipment utilized under these rates.

The equipment rates as determined above shall be full compensation, including overhead and profit, for providing the required equipment and no additional compensation will be made for other costs such as, but not limited to, fuels, lubricants, replacement parts or maintenance costs. Cost of repairs, both major and minor, as well as charges for mechanic's time utilized in servicing equipment to ready it for use prior to moving to the project and similar charges will not be allowed.

- d. Sales, consumer, use or similar taxes related to the Work, and for which the CONTRACTOR is liable, imposed by Regulatory Requirements.
- e. Deposits lost for causes other than negligence of the CONTRACTOR, any Subcontractor or anyone directly or indirectly employed by any of them or for whose acts any of them may be liable, and royalty payments and fees for permits and licenses.
- f. Losses and damages (and related expenses), not compensated by insurance or otherwise, to the Work or otherwise sustained by the CONTRACTOR in connection with the performance and furnishing of the Work provided they have resulted from causes other than the negligence of the CONTRACTOR, any Subcontractor, or anyone directly or indirectly employed by any of them or for whose acts any of them may be liable. Such losses shall include settlements made with the written consent and Approval of the AUTHORITY. No such losses, damages and expenses shall be included in the "cost of the work" for the purpose of determining the CONTRACTOR's fee. If, however, any such loss or damage requires reconstruction and the CONTRACTOR is placed in charge thereof, the CONTRACTOR shall be paid for services a fee proportionate to that stated in paragraphs 10.6.2.a and 10.6.2.b.
- g. The cost of utilities, fuel and sanitary facilities at the site.
- h. Minor expenses such as telegrams, long distance telephone calls, telephone service at the site, expressage and similar petty cash items in connection with the Work.
- I. Cost of premiums for additional bonds and insurance required because of changes in the Work and premiums for property insurance coverage within the limits of the deductible amounts established by the AUTHORITY in accordance with Article 5.

10.5 Excluded Costs:

The term "cost of the work" shall not include any of the following:

- 10.5.1 Payroll costs and other compensation of CONTRACTOR's officers, executives, principals (of partnership and sole proprietorships), general managers, engineers, architects, estimators, attorneys, auditors, accountants, purchasing agency, expeditors, timekeepers, clerks and other personnel employed by CONTRACTOR whether at the site or in CONTRACTOR's principal or a branch office for general administration of the Work and not specifically included in the agreed upon schedule of job classifications referred to in paragraph 10.4.1 or specifically covered by paragraph 10.4.4 all of which are to be considered administrative costs covered by the CONTRACTOR's fee.
- 10.5.2 Expenses of CONTRACTOR's principal and branch offices other than CONTRACTOR's office at the site.

- 10.5.3 Any part of CONTRACTOR's capital expenses including interest on CONTRACTOR's capital employed for the Work and charges against CONTRACTOR for delinquent payments.
- 10.5.4 Cost of premiums for all bonds and for all insurance whether or not CONTRACTOR is required by the Contract Documents to purchase and maintain the same (except for the cost of premiums covered by subparagraph 10.4.5.i above).
- 10.5.5 Costs due to the negligence of CONTRACTOR, any Subcontractor, or anyone directly or indirectly employed by any of them or for whose acts any of them may be liable, including but not limited to, the correction of Defective Work, disposal of materials or equipment wrongly supplied and making good any damage to property.
- 10.5.6 Other overhead or general expense costs of any kind and the costs of any item not specifically and expressly included in paragraph 10.4.

10.6 CONTRACTOR's Fee:

The CONTRACTOR's fee allowed to CONTRACTOR for overhead and profit shall be determined as follows.

- 10.6.1 A mutually acceptable fixed fee; or if none can be agreed upon.
- 10.6.2 A fee based on the following percentages of the various portions of the "cost of the work":
 - a. For costs incurred under paragraphs 10.4.1 and 10.4.2, the CONTRACTOR's fee shall be twenty percent;
 - b. For costs incurred under paragraph 10.4.3, the CONTRACTOR's fee shall be ten percent; and if a subcontract is on the basis of "cost of the work" plus a fee, the maximum allowable to CONTRACTOR on account of overhead and profit of all Subcontractors and multiple tiers thereof shall be fifteen percent;
 - c. No fee shall be payable on the basis of costs itemized under paragraphs 10.4.4, 10.4.5 and 10.5;
 - d. The amount of credit to be allowed by the CONTRACTOR to the AUTHORITY for any such change which results in a net decrease in cost will be the amount of the actual net decrease plus a deduction in CONTRACTOR's fee by an amount equal to ten percent of the net decrease; and
 - e. When both additions and credits are involved in any one change, the adjustment in CONTRACTOR's fee shall be computed on the basis of the net change in accordance with paragraphs 10.6.2.a through 10.6.2.d, inclusive.

10.7 Cost Breakdown:

Whenever the cost of any Work is to be determined pursuant to paragraphs 10.4 and 10.5, the CONTRACTOR will submit in a form acceptable to the AUTHORITY an itemized cost breakdown together with supporting data.

10.8 Cash Allowances:

It is understood that CONTRACTOR has included in the Contract Price all allowances so named in the Contract Documents and shall cause the Work so covered to be done by such Subcontractors

or Suppliers and for such sums within the limit of the allowances as may be acceptable to the Contracting Officer. CONTRACTOR agrees that:

- 10.8.1 The allowances include the cost to CONTRACTOR (less any applicable trade discounts) of materials and equipment required by the allowances to be delivered at the site, and all applicable taxes; and
- 10.8.2 CONTRACTOR's cost for unloading and handling on the site, labor, installation costs, overhead, profit and other expenses contemplated for the allowances have been included in the Contract Price and not in the allowances. No demand for additional payment on account of any thereof will be valid.

Prior to final payment, an appropriate Change Order will be issued to reflect actual amounts due the CONTRACTOR on account of Work covered by allowances, and the Contract Price shall be correspondingly adjusted.

10.9 Unit Price Work:

- 10.9.1 Where the Contract Documents provide that all or part of the Work is to be Unit Price Work, initially the Contract Price will be deemed to include for all Unit Price Work an amount equal to the sum of the established unit prices for each separately identified item of Unit Price Work times the estimated quantity of each item as indicated in the Contract. The estimated quantities of items of Unit Price Work are not guaranteed and are solely for the purpose of comparison of bids and determining an initial Contract Price. Determinations of the actual quantities and classifications of Unit Price Work performed by the CONTRACTOR will be made by the AUTHORITY in accordance with paragraph 10.10.
- 10.9.2 Each unit price will be deemed to include an amount considered by the CONTRACTOR to be adequate to cover the CONTRACTOR's overhead and profit for each separately identified item. If the "Basis of Payment" clause in the Contract Documents relating to any unit price in the bid schedule requires that the said unit price cover and be considered compensation for certain work or material essential to the item, this same work or material will not also be measured or paid for under any other pay item which may appear elsewhere in the Contract Documents.
- 10.9.3 Payment to the CONTRACTOR shall be made only for the actual quantities of Work performed and accepted or materials furnished, in conformance with the Contract Documents. When the accepted quantities of Work or materials vary from the quantities stated in the bid schedule, or change documents, the CONTRACTOR shall accept as payment in full, payment at the stated unit prices for the accepted quantities of Work and materials furnished, completed and accepted; except as provided below:
 - a. When the quantity of Work to be done or material to be furnished under any item, for which the total cost of the item exceeds 10% of the total Contract Price, is increased by more than 25 percent of the quantity stated in the bid schedule, or change documents, either party to the Contract, upon demand, shall be entitled to an equitable unit price adjustment on that portion of the Work above 125 percent of the quantity stated in the bid schedule.
 - b. When the quantity of Work to be done or material to be furnished under any major item, for which the total cost of the item exceeds 10% of the total Contract Price, is decreased by more than 25 percent of the quantity stated in the bid schedule, or change documents either party to the Contract, upon demand, shall be entitled to an equitable price adjustment for the quantity

of Work performed or material furnished, limited to a total payment of not more than 75 percent of the amount originally bid for the item.

10.10 Determinations for Unit Prices:

The Project Manager will determine the actual quantities and classifications of Unit Price Work performed by the CONTRACTOR. The Project Manager will review with the CONTRACTOR preliminary determinations on such matters before finalizing the costs and quantities on the Schedule of Values. The Project Manager's acknowledgment thereof will be final and binding on the CONTRACTOR, unless, within 10 days after the date of any such decisions, the CONTRACTOR delivers to the Project Manager written notice of intention to appeal from such a decision.

ARTICLE 11 - CONTRACT TIME; COMPUTATION AND CHANGE

11.1 Commencement of Contract Time; Notice to Proceed:

The Contract Time will commence to run on the day indicated in the Notice to Proceed.

11.2 Starting the Work:

No Work on Contract items shall be performed before the effective date of the Notice to Proceed. The CONTRACTOR shall notify the Project Manager at least 24 hours in advance of the time actual construction operations will begin. The CONTRACTOR may request a limited Notice to Proceed after Award has been made, to permit him to order long lead materials which could cause delays in Project completion. However, granting is within the sole discretion of the Contracting Officer, and refusal or failure to grant a limited Notice to Proceed shall not be a basis for claiming for delay, extension of time, or alteration of price.

11.3 Computation of Contract Time:

11.3.1 When the Contract Time is specified on a Calendar Day basis, all Work under the Contract shall be completed within the number of Calendar Days specified. The count of Contract Time begins on the day following receipt of the Notice to Proceed by the CONTRACTOR, if no starting day is stipulated therein.

Calendar Days shall continue to be counted against Contract Time until and including the date of Substantial Completion of the Work.

11.3.2 When the Contract completion time is specified as a fixed calendar date, it shall be the date of Final Completion.

11.3.3 The Contract Time shall be as stated in 00800, Supplementary Conditions.

11.4 Time Change:

The Contract Time may only be changed by a Change Order or Supplemental Agreement.

11.5 Extension Due to Delays:

The right of the CONTRACTOR to proceed shall not be terminated nor the CONTRACTOR charged with liquidated or actual damages because of delays to the completion of the Work due to unforeseeable causes beyond the control and without the fault or negligence of the

CONTRACTOR, including, but not restricted to the following: acts of God or of the public enemy, acts of the AUTHORITY in its contractual capacity, acts of another contractor in the performance of a contract with the AUTHORITY, floods, fires, epidemics, quarantine restrictions, strikes, freight embargoes, unusually severe weather and delays of Subcontractors or Suppliers due to such causes. Any delay in receipt of materials on the site, caused by other than one of the specifically mentioned occurrences above, does not of itself justify a time extension, provided that the CONTRACTOR shall within twenty four (24) hours from the beginning of any such delay (unless the Contracting Officer shall grant a further period of the time prior to the date of final settlement of the Contract), notify the Project Manager in writing of the cause of delay. The Contracting Officer shall ascertain the facts and the extent of the delay and extend the time for completing the Work when the findings of fact justify such an extension.

11.6 Essence of Contract:

All time limits stated in the Contract Documents are of the essence of the Contract.

11.7 Reasonable Completion Time:

It is expressly understood and agreed by and between the CONTRACTOR and the AUTHORITY that the date of beginning and the time for Substantial Completion of the Work described herein are reasonable times for the completion of the Work.

11.8 Delay Damages:

Whether or not the CONTRACTOR's right to proceed with the Work is terminated, he and his Sureties shall be liable for damages resulting from his refusal or failure to complete the Work within the specified time.

Liquidated and actual damages for delay shall be paid by the CONTRACTOR or his Surety to the AUTHORITY in the amount as specified in the Supplementary Conditions for each Calendar Day the completion of the Work or any part thereof is delayed beyond the time required by the Contract, or any extension thereof. If a listing of incidents resulting from a delay and expected to give rise to actual or liquidated damages is not established by the Contract Documents, then the CONTRACTOR and his Surety shall be liable to the AUTHORITY for any actual damages occasioned by such delay. The CONTRACTOR acknowledges that the liquidated damages established herein are not a penalty but rather constitute an estimate of damages that the AUTHORITY will sustain by reason of delayed completion. These liquidated and actual damages are intended as compensation for losses anticipated arising, and including those items enumerated in the Supplementary Conditions.

These damages will continue to run both before and after termination in the event of default termination. These liquidated damages do not cover excess costs of completion or AUTHORITY costs, fees, and charges related to reprocurement. If a default termination occurs, the CONTRACTOR or his Surety shall pay in addition to these damages, all excess costs and expenses related to completion as provided by Article 14.2.5.

For each calendar day that the work remains incomplete after the expiration of the Contract Time, liquidated damages in the amount as stated in 00800, Supplemental Conditions shall be assessed to the CONTRACTOR. If no money is due the CONTRACTOR, the AUTHORITY shall have the right to recover said sum from the CONTRACTOR, the surety or both. The amount of these deductions is to reimburse the AUTHORITY for estimated liquidated damages incurred as a result of the CONTRACTOR's failure to complete the work within the time specified. As liquidated

damages, such deductions are not to be considered as penalties.

Permitting the CONTRACTOR to continue and finish the work or any part of it after the time fixed for its completion, or after the date to which the time for completion may have been extended, will in no way operate as a waiver on the part of the AUTHORITY of any of its rights under the Contract.

ARTICLE 12 - QUALITY ASSURANCE

12.1 Warranty and Guaranty:

The CONTRACTOR warrants and guarantees to the AUTHORITY that all Work will be in accordance with the Contract Documents and will not be Defective. Prompt notice of all defects shall be given to the CONTRACTOR. All Defective Work, whether or not in place, may be rejected, corrected or accepted as provided for in this article.

12.2 Access to Work:

The AUTHORITY and the AUTHORITY's consultants, testing agencies and governmental agencies with jurisdiction interests will have access to the Work at reasonable times for their observation, inspecting and testing. The CONTRACTOR shall provide proper and safe conditions for such access.

12.3 Tests and Inspections:

- 12.3.1 The CONTRACTOR shall give the Project Manager timely notice of readiness of the Work for all required inspections, tests or Approvals.
- 12.3.2 If Regulatory Requirements of any public body having jurisdiction require any Work (or part thereof) to specifically be inspected, tested or approved, the CONTRACTOR shall assume full responsibility therefore, pay all costs in connection therewith and furnish the Project Manager the required certificates of inspection, testing or approval. The CONTRACTOR shall also be responsible for and shall pay all costs in connection with any inspection or testing required in connection with AUTHORITY's acceptance of a Supplier of materials or equipment proposed to be incorporated in the Work, or of materials or equipment submitted for Approval prior to the CONTRACTOR's purchase thereof for incorporation in the Work. The cost of all inspections, tests and approvals in addition to the above which are required by the Contract Documents shall be paid by the CONTRACTOR. The AUTHORITY may perform additional tests and inspections which it deems necessary to insure quality control. All such failed tests or inspections shall be at the CONTRACTOR's expense.
- 12.3.4 If any Work (including the work of others) that is to be inspected, tested or Approved is covered without written concurrence of the Project Manager, it must, if requested by the Project Manager, be uncovered for observation. Such uncovering shall be at the CONTRACTOR's expense unless the CONTRACTOR has given the Project Manager timely notice of CONTRACTOR's intention to cover the same and the Project Manager has not acted with reasonable promptness in response to such notice.
- 12.3.5 Neither observations nor inspections, tests or Approvals by the AUTHORITY or others shall relieve the CONTRACTOR from the CONTRACTOR's obligations to perform the Work in accordance with the Contract Documents.

12.4 Uncovering Work:

12.4.1 If any Work is covered contrary to the written request of the Project Manager, it must, if requested by the Project Manager, be uncovered for the Project Manager's observation and replaced at the CONTRACTOR's expense.

12.4.2 If the Project Manager considers it necessary or advisable that covered Work be observed inspected or tested, the CONTRACTOR, at the Project Manager's request, shall uncover, expose or otherwise make available for observation, inspection or testing as the Project Manager may require, that portion of the Work in question, furnishing all necessary labor, material and equipment. If it is found that such Work is Defective, the CONTRACTOR shall bear all direct, indirect and consequential costs of such uncovering, exposure, observation, inspection and testing and of satisfactory reconstruction, (including but not limited to fees and charges of engineers, architects, attorneys and other professionals) and the AUTHORITY shall be entitled to an appropriate decrease in the Contract Price. If, however, such Work is not found to be Defective, the CONTRACTOR shall be allowed an increase in the Contract Price or an extension of the Contract Time, or both, directly attributable to such uncovering, exposure, observation, inspection, testing and reconstruction.

12.5 AUTHORITY May Stop the Work:

If the Work is Defective, or the CONTRACTOR fails to supply suitable materials or equipment, or fails to furnish or perform the Work in such a way that the completed Work will conform to the Contract Documents, the Contracting Officer may order the CONTRACTOR to stop the Work, or any portion thereof, until the cause for such order has been eliminated; however, this right of the Contracting Officer to stop the Work shall not give rise to any duty on the part of the Contracting Officer to exercise this right for the benefit of the CONTRACTOR or any other party.

12.6 Correction or Removal of Defective Work:

If required by the Project Manager, the CONTRACTOR shall promptly, as directed, either correct all Defective Work, whether or not fabricated, installed or completed, or, if the Work has been rejected by the Project Manager, remove it from the site and replace it with Work which conforms to the requirements of the Contract Documents. The CONTRACTOR shall bear all direct, indirect and consequential costs of such correction or removal (including but not limited to fees and charges of engineers, architects, attorneys and other professionals) made necessary thereby.

12.7 One Year Correction Period:

If within one year after the date of Substantial Completion of the relevant portion of the Work or such longer period of time as may be prescribed by Regulatory Requirements or by the terms of any applicable special guarantee required by the Contract Documents or by any specific provision of the Contract Documents, any Work is found to be Defective, the CONTRACTOR shall promptly, without cost to the AUTHORITY and in accordance with the Project Manager's written instructions, either correct such Defective Work, or, if it has been rejected by the Project Manager, remove it from the site and replace it with conforming Work. If the CONTRACTOR does not promptly comply with the terms of such instructions, or in an emergency where delay would cause serious risk of loss or damage, the AUTHORITY may have the Defective Work corrected or the rejected Work removed and replaced, and all direct, indirect and consequential costs of such removal and replacement (including but not limited to fees and charges of engineers, architects, attorneys and other professionals) will be paid by the CONTRACTOR. In special circumstances where a particular item of equipment is placed in continuous service for the benefit of the

AUTHORITY before Substantial Completion of all the Work, the correction period for that item may begin on an earlier date if so provided in the Specifications or by Change Order. Provisions of this paragraph are not intended to shorten the statute of limitations for bringing an action.

12.8 Acceptance of Defective Work:

Instead of requiring correction or removal and replacement of Defective Work, the Project Manager may accept Defective Work, the CONTRACTOR shall bear all direct, indirect and consequential costs attributable to the Project Manager's evaluation of and determination to accept such Defective Work (costs to include but not be limited to fees and charges of engineers, architects, attorneys and other professionals). If any such acceptance occurs prior to final payment, a Change Order will be issued incorporating the necessary revisions in the Contract Documents with respect to the Work; and the AUTHORITY shall be entitled to an appropriate decrease in the Contract Price. If the AUTHORITY has already made final payment to the CONTRACTOR, an appropriate amount shall be paid by the CONTRACTOR or his Surety to the AUTHORITY.

12.9 AUTHORITY May Correct Defective Work:

If the CONTRACTOR fails within a reasonable time after written notice from the Project Manager to proceed to correct Defective Work or to remove and replace rejected Work as required by the Project Manager in accordance with paragraph 12.6, or if the CONTRACTOR fails to perform the Work in accordance with the Contract Documents, or if the CONTRACTOR fails to comply with any other provision of the Contract Documents, the AUTHORITY may, after 7 days' written notice to the CONTRACTOR, correct and remedy any such deficiency. In exercising the rights and remedies under this paragraph the AUTHORITY shall proceed expeditiously. To the extent necessary to complete corrective and remedial action, the Project Manager may exclude the CONTRACTOR from all or part of the site, take possession of all or part of the Work, and suspend the CONTRACTOR's services related thereto, take possession of the CONTRACTOR's tools, appliances, construction equipment and machinery at the site and incorporate in the Work all materials and equipment stored at the site or approved remote storage sites or for which the AUTHORITY has paid the CONTRACTOR but which are stored elsewhere. The CONTRACTOR shall allow the Project Manager and his authorized representatives such access to the site as may be necessary to enable the Project Manager to exercise the rights and remedies under this paragraph. All direct, indirect and consequential costs of the AUTHORITY in exercising such rights and remedies will be charged against the CONTRACTOR, and a Change Order will be issued incorporating the necessary revisions in the Contract Documents with respect to the Work; and the AUTHORITY shall be entitled to an appropriate decrease in the Contract Price. Such direct, indirect and consequential costs will include but not be limited to fees and charges of engineers, architects, attorneys and other professionals, all court and arbitration costs and all costs of repair and replacement of work of others destroyed or damaged by correction, removal or replacement of the CONTRACTOR's Defective Work. The CONTRACTOR shall not be allowed an extension of time because of any delay in performance of the work attributable to the exercise, by the Project Manager, of the AUTHORITY's rights and remedies hereunder.

ARTICLE 13 - PAYMENTS TO CONTRACTOR AND COMPLETION

13.1 Schedule of Values:

The Schedule of Values established as provided in paragraph 6.6 will serve as the basis for progress payments and will be incorporated into a form of Application for Payment acceptable to the Project Manager. Progress payments on account of Unit Price Work will be based on the number of units completed.

13.2 Preliminary Payments:

Upon approval of the Schedule of Values the CONTRACTOR may be paid for direct costs substantiated by paid invoices and other prerequisite documents required by the General Requirements. Direct costs shall include the cost of bonds, insurance, approved materials stored on the site or at approved remote storage sites, deposits required by a Supplier prior to fabricating materials, and other approved direct mobilization costs substantiated as indicated above. These payments shall be included as a part of the total Contract Price as stated in the Contract.

13.3 Application for Progress Payment:

The CONTRACTOR shall submit to the Project Manager for review an Application for Payment filled out and signed by the CONTRACTOR covering the Work completed as of the date of the Application for Payment and accompanied by such supporting documentation as is required by the Contract Documents. Progress payments will be made as the Work progresses on a monthly basis.

13.4 Review of Applications for Progress Payment:

Project Manager will either indicate in writing a recommendation of payment or return the Application for Payment to the CONTRACTOR indicating in writing the Project Manager's reasons for refusing to recommend payment. In the latter case, the CONTRACTOR may make the necessary corrections and resubmit the Application for Payment.

13.5 Stored Materials and Equipment:

If payment is requested on the basis of materials and equipment not incorporated in the Work but delivered and suitably stored at the site or at another location agreed to in writing, the Application for Payment shall also be accompanied by a bill of sale, paid invoice or other documentation warranting that the AUTHORITY has received the materials and equipment free and clear of all charges, security interests and encumbrances and evidence that the materials and equipment are covered by appropriate property insurance and other arrangements to protect the AUTHORITY's interest therein, all of which will be satisfactory to the Project Manager. No payment will be made for perishable materials that could be rendered useless because of long storage periods. No progress payment will be made for living plant materials until planted.

13.6 CONTRACTOR's Warranty of Title:

The CONTRACTOR warrants and guarantees that title to all Work, materials and equipment covered by any Application for Payment, whether incorporated in the Project or not, will pass to the AUTHORITY no later than the time of payment free and clear of any claims, liens, security interests and further obligations.

13.7 Withholding of Payments:

The AUTHORITY may withhold or refuse payment for any of the reasons listed below provided it gives written notice of its intent to withhold and of the basis for withholding:

13.7.1 The Work is Defective, or completed Work has been damaged requiring correction or replacement, or has been installed without Approval of Shop Drawings, or by an unapproved Subcontractor, or for unsuitable storage of materials and equipment.

13.7.2 The Contract Price has been reduced by Change Order,

- 13.7.3 The AUTHORITY has been required to correct Defective Work or complete Work in accordance with paragraph 12.9.
- 13.7.4 The AUTHORITY's actual knowledge of the occurrence of any of the events enumerated in paragraphs 14.2.1.a through 14.2.1.k inclusive.
- 13.7.5 Claims have been made against the AUTHORITY or against the funds held by the AUTHORITY on account of the CONTRACTOR's actions or inactions in performing this Contract, or there are other items entitling the AUTHORITY to a set off.
- 13.7.6 Subsequently discovered evidence or the results of subsequent inspections or test, nullify any previous payments for reasons stated in subparagraphs 13.7.1 through 13.7.5.
- 13.7.7 The CONTRACTOR has failed to fulfill or is in violation of any of his obligations under any provision of this Contract.

13.8 Retainage:

At any time the AUTHORITY finds that satisfactory progress is not being made it may in addition to the amounts withheld under 13.7 retain a maximum amount equal to 10% of the total amount earned on all subsequent progress payments. This retainage may be released at such time as the Project Manager finds that satisfactory progress is being made.

13.9 Request for Release of Funds:

If the CONTRACTOR believes the basis for withholding is invalid or no longer exists, immediate written notice of the facts and Contract provisions on which the CONTRACTOR relies, shall be given to the AUTHORITY, together with a request for release of funds and adequate documentary evidence proving that the problem has been cured. In the case of withholding which has occurred at the request of the Department of Labor, the CONTRACTOR shall provide a letter from the Department of Labor stating that withholding is no longer requested. Following such a submittal by the CONTRACTOR, the AUTHORITY shall have a reasonable time to investigate and verify the facts and seek additional assurances before determining whether release of withheld payments is justified.

13.10 Substantial Completion:

When the CONTRACTOR considers the Work ready for its intended use the CONTRACTOR shall notify the Project Manager in writing that the Work or a portion of Work which has been specifically identified in the Contract Documents is substantially complete (except for items specifically listed by the CONTRACTOR as incomplete) and request that the AUTHORITY issue a certificate of Substantial Completion. Within a reasonable time thereafter, the Project Manager, the CONTRACTOR and Engineer(s) shall make an inspection of the Work to determine the status of completion. If the Project Manager does not consider the Work substantially complete, the Project Manager will notify the CONTRACTOR in writing giving the reasons therefore. If the Project Manager considers the Work substantially complete, the Project Manager will within fourteen days execute and deliver to the CONTRACTOR a certificate of Substantial Completion with tentative list of items to be completed or corrected. At the time of delivery of the certificate of Substantial Completion the Project Manager will deliver to the CONTRACTOR a written division of responsibilities pending Final Completion with respect to security, operation, safety, maintenance, heat, utilities, insurance and warranties which shall be consistent with the terms of the Contract Documents.

The AUTHORITY shall be responsible for all AUTHORITY costs resulting from the initial inspection and the first re-inspection, the CONTRACTOR shall pay all costs incurred by the AUTHORITY resulting from re-inspections, thereafter.

13.11 Access Following Substantial Completion:

The AUTHORITY shall have the right to exclude the CONTRACTOR from the Work after the date of Substantial Completion, but the AUTHORITY shall allow CONTRACTOR reasonable access to complete or correct items on the tentative list.

13.12 Final Inspection:

Upon written notice from the CONTRACTOR that the entire Work or an agreed portion thereof is complete, the Project Manager will make a final inspection with the CONTRACTOR and Engineer(s) and will notify the CONTRACTOR in writing of all particulars in which this inspection reveals that the Work is incomplete or Defective. The CONTRACTOR shall immediately take such measures as are necessary to remedy such deficiencies. The CONTRACTOR shall pay for all costs incurred by the AUTHORITY resulting from re-inspections.

13.13 Final Completion and Application for Payment:

After the CONTRACTOR has completed all such corrections to the satisfaction of the Project Manager and delivered schedules, guarantees, bonds, certificates of payment to all laborers, Subcontractors and Suppliers, and other documents - all as required by the Contract Documents; and after the Project Manager has indicated in writing that the Work has met the requirements for Final Completion, and subject to the provisions of paragraph 13.18, the CONTRACTOR may make application for final payment following the procedure for progress payments. The final Application for Payment shall be accompanied by all remaining certificates, warranties, guarantees, releases, affidavits, and other documentation required by the Contract Documents.

13.14 Final Payment:

13.14.1 If on the basis of the Project Manager's observation of the Work during construction and final inspection, and the Project Manager's review of the final Application for Payment and accompanying documentation - all as required by the Contract Documents; and the Project Manager is satisfied that the Work has been completed and the CONTRACTOR's other obligations under the Contract Documents have been fulfilled, the AUTHORITY will process final Application for Payment. Otherwise, the Project Manager will return the Application for Payment to the CONTRACTOR, indicating in writing the reasons for refusing to process final payment, in which case the CONTRACTOR shall make the necessary corrections and resubmit the final Application for Payment.

13.14.2 If, through no fault of the CONTRACTOR, Final Completion of the Work is significantly delayed, the Project Manager shall, upon receipt of the CONTRACTOR's final Application for Payment, and without terminating the Contract, make payment of the balance due for that portion of the Work fully completed and accepted. If the remaining balance to be held by the AUTHORITY for Work not fully completed or corrected is less than the retainage provided for in paragraph 13.9, and if bonds have been furnished as required in paragraph 5.1, the written consent of the Surety to the payment of the balance due for that portion of the Work fully completed and accepted shall be submitted by the CONTRACTOR to the AUTHORITY with the application for such payment. Such payment shall be made under the terms and conditions governing final payment, except that it shall not constitute a waiver of claims.

13.15 Final Acceptance:

Following certification of payment of payroll and revenue taxes, and final payment to the CONTRACTOR, the AUTHORITY will issue a letter of Final Acceptance, releasing the CONTRACTOR from further obligations under the Contract, except as provided in paragraph 13.17.

When it is anticipated that restarting, testing, adjusting, or balancing of systems will be required following Final Acceptance and said requirements are noted in Section(s) 01 77 00, such Work shall constitute a continuing obligation under the Contract.

13.16 CONTRACTOR's Continuing Obligation:

The CONTRACTOR's obligation to perform and complete the Work and pay all laborers, Subcontractors, and material men in accordance with the Contract Documents shall be absolute. Neither any progress or final payment by the AUTHORITY, nor the issuance of a certificate of Substantial Completion, nor any use or occupancy of the Work or any part thereof by the AUTHORITY or Owner, nor any act of acceptance by the AUTHORITY nor any failure to do so, nor any review and Approval of a Shop Drawing or sample submission, nor any correction of Defective Work by the AUTHORITY will constitute an acceptance of Work not in accordance with the Contract Documents or a release of the CONTRACTOR's obligation to perform the Work in accordance with the Contract Documents.

13.17 Waiver of Claims by CONTRACTOR:

The making and acceptance of final payment will constitute a waiver of all claims by the CONTRACTOR against the AUTHORITY other than those previously made in writing and still unsettled.

13.18 No Waiver of Legal Rights:

The AUTHORITY shall not be precluded or be estopped by any payment, measurement, estimate, or certificate made either before or after the completion and acceptance of the Work and payment therefore, from showing the true amount and character of the Work performed and materials furnished by the CONTRACTOR, nor from showing that any payment, measurement, estimate or certificate is untrue or is incorrectly made, or that the Work or materials are Defective. The AUTHORITY shall not be precluded or estopped, notwithstanding any such measurement, estimate, or certificate and payment in accordance therewith, from recovering from the CONTRACTOR or his Sureties, or both, such damages as it may sustain by reason of his failure to comply with requirements of the Contract Documents. Neither the acceptance by the AUTHORITY, or any representative of the AUTHORITY, nor any payment for or acceptance of the whole or any part of the Work, nor any extension of the Contract Time, nor any possession taken by the AUTHORITY, shall operate as a waiver of any portion of the Contract or of any power herein reserved, or of any right to damages. A waiver by the AUTHORITY of any breach of the Contract shall not be held to be a waiver of any other subsequent breach.

ARTICLE 14 - SUSPENSION OF WORK, DEFAULT AND TERMINATION

14.1 AUTHORITY May Suspend Work:

14.1.1 The AUTHORITY may, at any time, suspend the Work or any portion thereof by notice in writing to the CONTRACTOR. If the Work is suspended without cause the CONTRACTOR shall be allowed an increase in the Contract Price or an extension of the Contract Time, or both,

directly attributable to any suspension if the CONTRACTOR makes an Approved claim therefore as provided in Article 15. However, no adjustment shall be made under this clause for any suspension, delay, or interruption to the extent that suspension is due to the fault or negligence of the CONTRACTOR, or that suspension is necessary for Contract compliance, or that performance would have been so suspended, delayed, or interrupted by any other cause, including the fault or negligence of the CONTRACTOR.

14.1.2 In case of suspension of Work, the CONTRACTOR shall be responsible for preventing damage to or loss of any of the Work already performed and of all materials whether stored on or off the site or Approved remote storage sites.

14.2 Default of Contract:

14.2.1 The Contracting Officer may give the contractor and his surety a written Notice to Cure Default if the contractor:

- a. fails to begin work in the time specified,
- b. fails to use sufficient resources to assure prompt completion of the work,
- c. performs the work unsuitably or neglect or refuse to remove and replace rejected materials or work,
- d. stops work,
- e. fails to resume stopped work after receiving notice to do so,
- f. becomes insolvent (except that if you declare bankruptcy, termination will be under Title 11 US Code 362 and/or 365. Your bankruptcy does not relieve the surety of any obligations to assume the Contract and complete the work in a timely manner.
- g. Allows any final judgment to stand against him unsatisfied for period of 60 days, or
- h. Makes an assignment for the benefit of creditors without the consent of the Contracting Officer, or
- i. Disregards Regulatory Requirements of any public body having jurisdiction, or
- j. Otherwise violates in any substantial way any provisions of the Contract Documents, or
- k. fails to comply with Contract minimum wage payments or civil rights requirements, or
- l. are party to fraud, deception, misrepresentation , or
- m. for any cause whatsoever, fails to carry on the Work in an acceptable manner.

14.2.2 The Notice to Cure Default will detail the conditions determined to be in default, the time within which to cure the default and may, in the Contracting Officer's discretion, specify the actions necessary to cure the default. Failure to cure the delay, neglect or default within the time specified in the Contracting Officer's written notice to cure authorizes the Authority to terminate the contract. The Contracting Officer may allow more time to cure than originally stated in the Notice to Cure Default if he deems it to be in the best interests of the Authority. The Authority will provide you and your surety with a written Notice of Default Termination that details the default and the failure to cure it.

- 14.2.3 If the CONTRACTOR or Surety, within the time specified in the above notice of default, shall not proceed in accordance therewith, then the AUTHORITY may, upon written notification from the Contracting Officer of the fact of such delay, neglect or default and the CONTRACTOR's failure to comply with such notice, have full power and authority without violating the Contract, to take the prosecution of the Work out of the hands of the CONTRACTOR. The AUTHORITY may terminate the services of the CONTRACTOR, exclude the CONTRACTOR from the site and take possession of the Work and of all the CONTRACTOR's tools, appliances, construction equipment and machinery at the site and use the same to the full extent they could be used by the CONTRACTOR (without liability to the CONTRACTOR for trespass or conversion), incorporate in the Work all materials and equipment stored at the site or for which the AUTHORITY has paid the CONTRACTOR but which are stored elsewhere, and finish the Work as the AUTHORITY may deem expedient. The AUTHORITY may enter into an agreement for the completion of said Contract according to the terms and provisions thereof, or use such other methods that in the opinion of the Contracting Officer are required for the completion of said Contract in an acceptable manner.
- 14.2.4 The Contracting Officer may, by written notice to the CONTRACTOR and his Surety or his representative, transfer the employment of the Work from the CONTRACTOR to the Surety, or if the CONTRACTOR abandons the Work undertaken under the Contract, the Contracting Officer may, at his option with written notice to the Surety and without any written notice to the CONTRACTOR, transfer the employment for said Work directly to the Surety. The Surety shall submit its plan for completion of the Work, including any contracts or agreements with third parties for such completion, to the AUTHORITY for Approval prior to beginning completion of the Work. Approval of such contracts shall be in accordance with all applicable requirements and procedures for Approval of subcontracts as stated in the Contract Documents.
- 14.2.5 After the notice of termination is issued, the Authority may take over the work and complete it by contract or otherwise and may take possession of and use materials, appliances, equipment or plant on the work site necessary for completing the work.
- 14.2.6 Rather than taking over the work itself, the Authority may transfer the obligation to perform the work from the contractor to your surety. The surety must submit its plan for completion of the work, including any contracts or agreements with third parties for completion, to the Authority for approval prior to beginning work. The surety must follow the Contract requirements for approval of subcontracts, except that the limitation on percent of work subcontracted will not apply.
- 14.2.7 On receipt of the transfer notice, the surety must take possession of all materials, tools, and appliances at the work site, employ an appropriate work force, and complete the Contract work, as specified. The Contract specifications and requirements shall remain in effect. However the Authority will make subsequent Contract payments directly to the Surety for work performed under the terms of the Contract. CONTRACTOR forfeits any right to claim for the same work or any part thereof. CONTRACTOR is not entitled to receive any further balance of the amount to be paid under the Contract.
- 14.2.8 Upon receipt of the notice terminating the services of the CONTRACTOR, the Surety shall enter upon the premises and take possession of all materials, tools, and appliances thereon for the purpose of completing the Work included under the Contract and employ by contract or otherwise any person or persons to finish the Work and provide the materials therefore, without termination of the continuing full force and effect of this Contract. In case of such transfer of employment to the Surety, the Surety shall be paid in its own name on estimates covering Work subsequently performed under the terms of the Contract and according to the terms thereof without any right of the CONTRACTOR to make any claim for the same or any part thereof.

- 14.2.9 If the Contract is terminated for default, the CONTRACTOR and the Surety shall be jointly and severally liable for damages for delay as provided by paragraph 11.8, and for the excess cost of completion, and all costs and expenses incurred by the AUTHORITY in completing the Work or arranging for completion of the Work, including but not limited to costs of assessing the Work to be done, costs associated with advertising, soliciting or negotiating for bids or proposals for completion, and other procurement costs. Following termination the CONTRACTOR shall not be entitled to receive any further balance of the amount to be paid under the Contract until the Work is fully finished and accepted, at which time if the unpaid balance exceeds the amount due the AUTHORITY and any amounts due to persons for whose benefit the AUTHORITY has withheld funds, such excess shall be paid by the AUTHORITY to the CONTRACTOR. If the damages, costs, and expenses due the AUTHORITY exceed the unpaid balance, the CONTRACTOR and his Surety shall pay the difference.
- 14.2.10 If, after notice of termination of the CONTRACTOR's right to proceed under the provisions of this clause, it is determined for any reason that the CONTRACTOR was not in default under the provisions of this clause, or that the delay was excusable under the provisions of this clause, or that termination was wrongful, the rights and obligations of the parties shall be determined in accordance with the clause providing for convenience termination.

14.3 Rights or Remedies:

Where the CONTRACTOR's services have been so terminated by the AUTHORITY, the termination will not affect any rights or remedies of the AUTHORITY against the CONTRACTOR then existing or which may thereafter accrue. Any retention or payment of moneys due the CONTRACTOR by the AUTHORITY will not release the CONTRACTOR from liability.

14.4 Convenience Termination:

- 14.4.1 The performance of the Work may be terminated by the AUTHORITY in accordance with this section in whole or in part, whenever, for any reason the Contracting Officer shall determine that such termination is in the best interest of the OWNER. Any such termination shall be effected by delivery to the CONTRACTOR of a Notice of Termination, specifying termination is for the convenience of the AUTHORITY the extent to which performance of Work is terminated, and the date upon which such termination becomes effective.
- 14.4.2 Immediately upon receipt of a Notice of Termination and except as otherwise directed by the Contracting Officer, the CONTRACTOR shall:
- a. Stop Work on the date and to the extent specified in the Notice of Termination;
 - b. Place no further orders or subcontracts for materials, services, or facilities except as may be necessary for completion of such portion of the Work as is not terminated;
 - c. Terminate all orders and subcontracts to the extent that they relate to the performance of Work terminated by the Notice of Termination;
 - d. With the written Approval of the Contracting Officer, to the extent he may require, settle all outstanding liabilities and all claims arising out of such termination of orders and subcontracts, the cost of which would be reimbursable, in whole, or in part, in accordance with the provisions of the Contract;

- e. Submit to the Contracting Officer a list, certified as to quantity and quality, of any or all items of termination inventory exclusive of items the disposition of which had been directed or authorized by the Contracting Officer;
- f. Transfer to the Contracting Officer the completed or partially completed record drawings, Shop Drawings, information, and other property which, if the Contract had been completed, would be required to be furnished to the AUTHORITY;
- g. Take such action as may be necessary, or as the Contracting Officer may direct, for the protection and preservation of the property related to the Contract which is in the possession of the CONTRACTOR and in which the AUTHORITY has or may acquire any interest.

The CONTRACTOR shall proceed immediately with the performance of the above obligations.

14.4.3 When the AUTHORITY orders termination of the Work effective on a certain date, all Work in place as of that date will be paid for in accordance with Article 13 of the Contract. Materials required for completion and on hand but not incorporated in the Work will be paid for at invoice cost plus 15 % with materials becoming the property of the AUTHORITY - or the CONTRACTOR may retain title to the materials and be paid an agreed upon lump sum. Materials on order shall be cancelled, and the AUTHORITY shall pay reasonable factory cancellation charges with the option of taking delivery of the materials in lieu of payment of cancellation charges. The CONTRACTOR shall be paid 10% of the cost, freight not included, of materials cancelled, and direct expenses only for CONTRACTOR chartered freight transport which cannot be cancelled without charges, to the extent that the CONTRACTOR can establish them. The extra costs due to cancellation of bonds and insurance and that part of job start-up and phase-out costs not amortized by the amount of Work accomplished shall be paid by the AUTHORITY. Charges for loss of profit or consequential damages shall not be recoverable except as provided above.

- a. The following costs are not payable under a termination settlement agreement or Contracting Officer's determination of the termination claim:
 - 1. Loss of anticipated profits or consequential or compensatory damages
 - 2. Unabsorbed home office overhead (also termed "General & Administrative Expense") related to ongoing business operations
 - 3. Bidding and project investigative costs
 - 4. Direct costs of repairing equipment to render it operable for use on the terminated work

14.4.4 The termination claim shall be submitted promptly, but in no event later than 90 days from the effective date of termination, unless extensions in writing are granted by the Contracting Officer upon written request of the CONTRACTOR made within the 90 day period. Upon failure of the CONTRACTOR to submit his termination claim within the time allowed, the Contracting Officer may determine, on the basis of information available to him, the amount, if any, due to the CONTRACTOR by reason of the termination and shall thereupon pay to the CONTRACTOR the amount so determined.

14.4.5 The CONTRACTOR and the Contracting Officer may agree upon whole or any part of the amount or amounts to be paid to the CONTRACTOR by reason of the total or partial termination of Work pursuant to this section. The Contract shall be amended accordingly, and the CONTRACTOR shall be paid the agreed amount.

14.4.6 In the event of the failure of the CONTRACTOR and the Contracting Officer to agree in whole or in part, as provided heretofore, as to the amounts with respect to costs to be paid to the CONTRACTOR in connection with the termination of the Work the Contracting Officer shall determine, on the basis of information available to him, the amount, if any, due to the CONTRACTOR by reason of the termination and shall pay to the CONTRACTOR the amount determined as follows:

- a. All costs and expenses reimbursable in accordance with the Contract not previously paid to the CONTRACTOR for the performance of the Work prior to the effective date of the Notice of Termination;
- b. So far as not included under "a" above, the cost of settling and paying claims arising out of the termination of the Work under subcontracts or orders which are properly chargeable to the terminated portions of the Contract;
- c. So far as practicable, claims by the contractor for idled or stand-by equipment shall be made as follows: Equipment claims will be reimbursed as follows:
 1. Contractor-owned equipment usage, based on the contractor's ownership and operating costs for each piece of equipment as determined from the contractor's accounting records. Under no circumstance, may the contractor base equipment claims on published rental rates.
 2. Idle or stand-by time for Contractor-owned equipment, based on your internal ownership and depreciation costs. Idle or stand-by equipment time is limited to the actual period of time equipment is idle or on stand-by as a direct result of the termination, not to exceed 30 days. Operating expenses will not be included for payment of idle or stand-by equipment time.
 3. Rented equipment, based on reasonable, actual rental costs. Equipment leased under "capital leases" as defined in Financial Accounting Standard No. 13 will be considered Contractor-owned equipment. Equipment leased from an affiliate, division, subsidiary or other organization under common control with you will be considered Contractor-owned equipment, unless the lessor has an established record of leasing to unaffiliated lessees at competitive rates consistent with the rates you have agreed to pay and no more than forty percent of the lessor's leasing business, measured in dollars, is with organizations affiliated with the lessor.

14.4.7 The CONTRACTOR shall have the right of appeal under the AUTHORITY's claim procedures, as defined in Article 15, for any determination made by the Contracting Officer, except if the CONTRACTOR has failed to submit his claim within the time provided and has failed to request extension of such time, CONTRACTOR shall have no such right of appeal. In arriving at the amount due the CONTRACTOR under this section, there shall be deducted:

- a. All previous payments made to the CONTRACTOR for the performance of Work under the Contract prior to termination;
- b. Any claim for which the AUTHORITY may have against the CONTRACTOR;
- c. The agreed price for, or the proceeds of sale of, any materials, supplies, or other things acquired by the CONTRACTOR or sold pursuant to the provisions of this section and not otherwise recovered by or credited to the AUTHORITY; and,
- d. All progress payments made to the CONTRACTOR under the provisions of this section.

- 14.4.8 Where the Work has been terminated by the AUTHORITY said termination shall not affect or terminate any of the rights of the AUTHORITY against the CONTRACTOR or his Surety then existing or which may thereafter accrue because of such default. Any retention or payment of monies by the AUTHORITY due to the CONTRACTOR under the terms of the Contract shall not release the CONTRACTOR or his Surety from liability.
- 14.4.9 The contractor's termination claim may not include claims that pre dated the notice for termination for convenience. Those claims shall be prosecuted by the contractor under Article 15.
- 14.4.10 The contractor's termination claim may not exceed the total dollar value of the contract as awarded plus agreed upon change orders less the amounts that have been paid for work completed.
- a. Unless otherwise provided for in the Contract Documents, or by applicable statute, the CONTRACTOR, from the effective date of termination and for a period of three years after final settlement under this Contract, shall preserve and make available to the AUTHORITY at all reasonable times at the office of the CONTRACTOR, all its books, records, documents, and other evidence bearing on the cost and expenses of the CONTRACTOR under his Contract and relating to the Work terminated hereunder.
 - b. Cost Principles. The Authority may use the federal cost principles at 48 CFR §§ 31.201-1 to 31.205-52 (or succeeding cost principles for fixed price contracts) as guidelines in determining allowable costs under this Subsection to the extent they are applicable to construction contracts and consistent with the specifications of this Contract. The provisions of this contract control where they are more restrictive than, or inconsistent with, these federal cost principles.”

ARTICLE 15 - CLAIMS AND DISPUTES

15.1 Notification

- 15.1.1 The CONTRACTOR shall notify the AUTHORITY in writing as soon as the CONTRACTOR becomes aware of any act or occurrence which may form the basis of a claim for additional compensation or an extension of Contract Time or of any dispute regarding a question of fact or interpretation of the Contract. The AUTHORITY has no obligation to investigate any fact or occurrence that might form the basis of a claim or to provide any additional compensation or extension of Contract Time unless the CONTRACTOR has notified the AUTHORITY in writing in a timely manner of all facts the CONTRACTOR believes form the basis for the claim.
- 15.1.2 If the CONTRACTOR believes that he is entitled to an extension of Contract Time, then the CONTRACTOR must state the contract section on which he basis his extension request, provide the AUTHORITY with sufficient information to demonstrate that the CONTRACTOR has suffered excusable delay, and show the specific amount of time to which the CONTRACTOR is entitled. The AUTHORITY will not grant an extension of Contract Time if the CONTRACTOR does not timely submit revised schedules under **Section 01 32 00**.
- 15.1.3 If the matter is not resolved by agreement within 7 days, the CONTRACTOR shall submit an Intent to Claim, in writing, to the AUTHORITY within the next 14 days.
- 15.1.4 If the CONTRACTOR believes additional compensation or time is warranted, then he must immediately begin keeping complete, accurate, and specific daily records concerning every detail of the potential claim including actual costs incurred. The

CONTRACTOR shall provide the AUTHORITY access to any such records and furnish the AUTHORITY copies, if requested. Equipment costs must be based on the CONTRACTOR's internal rates for ownership, depreciation, and operating expenses and not on published rental rates. In computing damages, or costs claimed for a change order, or for any other claim against the Authority for additional time, compensation or both, the contractor must prove actual damages based on internal costs for equipment, labor or efficiencies. Total cost, modified total cost or jury verdict forms of presentation of damage claims are not permissible to show damages. Labor inefficiencies must be shown to actually have occurred and can be proven solely based on job records. Theoretical studies are not a permissible means of showing labor inefficiencies. Home office overhead will not be allowed as a component of any claim against the Authority.

- 15.1.5 If the claim or dispute is not resolved by the Project Manager, then the CONTRACTOR shall submit a written Claim to the Contracting Officer within 90 days after the CONTRACTOR becomes aware of the basis of the claim or should have known the basis of the claim, whichever is earlier. The Contracting Officer will issue written acknowledge of the receipt of the Claim.
- 15.1.6 The CONTRACTOR waives any right to claim if the AUTHORITY was not notified properly or afforded the opportunity to inspect conditions or monitor actual costs or if the Claim is not filed on the date required.

15.2 Presenting the Claim

- 15.2.1 The Claim must include all of the following:
- a. The act, event, or condition the claim is based on
 - b. The Contract provisions which apply to the claim and provide relief
 - c. The item or items of Contract work affected and how they are affected
 - d. The specific relief requested, including Contract Time if applicable, and the basis upon which it was calculated
 - e. A statement certifying that the claim is made in good faith, that the supporting cost and pricing data are accurate and complete to the best of your knowledge and belief, and that the amount requested accurately reflects the Contract adjustment which the CONTRACTOR believes is due.

15.3 Claim Validity, Additional Information, and AUTHORITY's Action

- 15.3.1 The Claim, in order to be valid, must not only show that the CONTRACTOR suffered damages or delay but that it was caused by the act, event, or condition complained of and that the Contract provides entitlement to relief for such act, event, or condition.
- 15.3.2 The AUTHORITY can make written request to the CONTRACTOR at any time for additional information relative to the Claim. The CONTRACTOR shall provide the AUTHORITY the additional information within 30 days of receipt of such a request. Failure to furnish the additional information may be regarded as a waiver of the Claim.

15.4 Contracting Officer's Decision

- 15.4.1 The CONTRACTOR will be furnished the Contracting Officer's Decision within 90 days, unless the Contracting Officer requests additional information or gives the CONTRACTOR notice that the time for issuing a decision is being extended for a specified period. The Contracting Officer's decision is final and conclusive unless,

within 14 days of receipt of the decision, the CONTRACTOR delivers a Notice of Appeal to the Executive Director of the Authority.

15.5 Appeals on a Contract Claim.

15.5.1 An appeal from a decision of the Contracting Officer on a contract claim may be filed by the CONTRACTOR with the Executive Director of the Authority. The appeal shall be filed within 14 days after the decision is received by the CONTRACTOR. An appeal by the CONTRACTOR may not raise any new factual issues or theories of recovery that were not presented to and decided by the Contracting Officer in the decision under Section 15.4, except that a CONTRACTOR may increase the contractor's calculation of damages if the increase arises out of the same operative facts on which the original claim was based. The CONTRACTOR shall file a copy of the appeal with the Contracting Officer.

- a. An appeal must contain a copy of the decision being appealed and identification of the factual or legal errors in the decision that form the basis for the appeal.
- b. The Executive Director shall handle the appeal of a claim under this section expeditiously.

15.6 Construction Contract Claim Appeals.

15.6.1 The appeal from a decision of the Contracting Officer of a claim involving a construction contract shall be resolved by:

- a. binding and final arbitration under AS 09.43.010 - 09.43.180 (Uniform Arbitration Act) if the claim is:
 1. less than \$250,000 and the CONTRACTOR requests arbitration of the claim; or
 2. \$250,000 or more and both the agency and the CONTRACTOR agree to arbitration of the claim; or
- b. a hearing under the Authority's established policy and procedures if the claim is not handled by arbitration under 15.6.1 of this subsection.

15.7 Fraud and Misrepresentation in Making Claims

Criminal and Civil penalties authorized under State or federal law (including, but not limited to, forfeiture of all claimed amounts) may be imposed on the CONTRACTOR if the CONTRACTOR makes or uses a misrepresentation in support of a claim or defraud or attempt to defraud the AUTHORITY at any stage of prosecuting a claim under this Contract.”

This page is blank intentionally.

SECTION 00 80 00 SUPPLEMENTARY CONDITIONS

MODIFICATIONS TO THE GENERAL CONDITIONS 00 70 00

The following supplements modify, change, delete from, or add to Section 00 70 00 "General Conditions of the Construction Contract for Buildings", revised December, 2011. Where any article of the General Conditions is modified, or a Paragraph, Subparagraph, or Clause thereof is modified or deleted by these Supplementary Conditions, the unaltered provisions of that Article, Paragraph, Subparagraph, or Clause shall remain in effect.

SC-1-DEFINITIONS

A. Add the following definitions:

1. **QUALITY ASSURANCE ACCEPTANCE TESTING** – This is all sampling and testing performed by the CONTRACTOR to determine at what level the product or service will be accepted for payment. Qualified personnel and laboratories will perform sampling and testing. The AUTHORITY pays for this testing.
2. **QUALITY CONTROL PROGRAM (QC PROGRAM)** – The CONTRACTOR'S, Subcontractor's or Supplier's operational techniques and activities that maintain control of the construction process to fulfill the Contract requirements. This may include materials handling, construction procedures, calibration and maintenance of equipment, production process control, material sampling, testing and inspection, and data analysis.
3. **RESIDENT ENGINEER** - The Engineer's authorized representative assigned to make detailed observations relating to contract performance.

SC-2.4-VISITS TO SITE/PLACE OF BUSINESS

At General Conditions Article 2.4, delete the first four words of the first sentence ("The Contracting Officer will ...") and replace with the following words "The Contracting Officer has the right to, but is not obligated to..."

SC-4.3-EXPLORATIONS AND REPORTS

At General Conditions Article 4.3, add the following paragraph:

"All reports and other records (if available) are provided for informational purposes only to all plan holders listed with the AUTHORITY as General Contractors, and are available to other planholders upon request. They are made available so Bidders have access to the same information available to the AUTHORITY. The reports and other records are not intended as a substitute for independent investigation, interpretation, or judgment of the Bidder. The AUTHORITY is not responsible for any interpretation or conclusion drawn from its records by the Bidder. While referenced by or provided with the Contract Documents; the recommendations, engineering details, and other information contained in these reports of explorations shall not be construed to supersede or constitute conditions of the Contract Documents."

SC-4.7 – SURVEY CONTROL

At General Conditions Article 4.7, delete the section in its entirety. See Section 01 71 23.16 - Construction Surveying for project specific surveying requirements.

SC-5.4.3 – INSURANCE REQUIREMENTS

At General Condition Article 5.4.3 add the following:

- "d. The delivery to the AUTHORITY of a written notice in accordance with the policy provisions is required before cancellation of any coverage or reduction in any limits of liability."

SC-5.4.2a – WORKERS COMPENSATION INSURANCE

At General Condition Article 5.4.2a, delete paragraph "a" in its entirety and replace with the following:

- "a. Workers' Compensation Insurance: The Contractor shall provide and maintain, for all employees of the Contractor engaged in work under this contract, Workers' Compensation Insurance as required by AS 23.30.045. The Contractor shall be responsible for Workers' Compensation Insurance for any subcontractor who provides services under this contract. Coverage shall include:
 1. Waiver of subrogation against the Authority.
 2. Employer's Liability Protection in the amount of \$500,000 each accident / \$500,000 each disease.
 3. If the Contractor directly utilizes labor outside of the State of Alaska in the prosecution of the work, "Other States" endorsement shall be required as a condition of the contract.
 4. Whenever the work involves activity on or about navigable waters, the Workers' Compensation policy shall contain a United States Longshoreman's and Harbor Worker's Act endorsement, and when appropriate, a Maritime Employer's Liability (Jones Act) endorsement with a minimum limit of \$1,000,000."

SC-5.4.2 b- COMMERCIAL GENERAL LIABILITY INSURANCE

At General Conditions Article 5.4.2.b, remove and replace the last sentence with the following:

"The following parties shall be named as "Additional Insured" under all liability coverages listed above:

- The Authority
- The City of Napaskiak

SC-5.4.2d- BUILDER'S RISK INSURANCE

At General Conditions Article 5.4.2.d, delete the subsection in its entirety.

SC – 6.13 – SUBCONTRACTORS

Add new general conditions Article 6.13.7 as follows:

6.13.7 The Contractor may, without penalty, replace a subcontractor who:

1. Fails to comply with the licensing and registration requirements as AS 08.18;
2. Fails to obtain or maintain a valid Alaska Business License;
3. Files for bankruptcy or becomes insolvent;
4. Fails to execute a subcontract or performance of the work for which the subcontractor was listed, and the Contractor has acted in good faith;
5. Fails to obtain bonding acceptable to the AUTHORITY;
6. Fails to obtain insurance acceptable to the AUTHORITY;
7. Fails to perform subcontract work for which the subcontractor was listed;
8. Must be replaced to meet the Contractor's required state or federal affirmative action requirements.
9. Refuses to agree to abide by the Contractor's labor agreement; or
10. Is determined by the AUTHORITY to be not responsible.

In addition to the circumstances described above, a Contractor may in writing request permission from the AUTHORITY to add a new subcontractor or replace a listed subcontractor. The AUTHORITY will approve the request if it determines in writing that allowing the addition or replacement is in the best interest of the AUTHORITY.

The Contractor shall submit a written request to add a new Subcontractor or replace a listed Subcontractor to the Contracting Officer a minimum of five working days prior to the date the new Subcontractor is scheduled to be work on the construction site. The request must state the basis for the request and include supporting documentation acceptable to the Contracting Officer.

If a Contractor violates this article, the Contracting Officer may;

1. Cancel the Contract after Award without any damages accruing to the AUTHORITY; or
2. After notice and hearing, assess a penalty on the bidder in an amount not exceeding 0 percent of the value of the subcontract at issue.

SC-7.14 – WAGES AND HOURS OF LABOR

General Condition Article 7.14.1 (Certified Payroll) and Article 7.14.3 (D.O.L. Notification) shall apply to all on site work in Napaskiak. This is because the City of Napaskiak is a political subdivision of the State of Alaska and this work is subject to AS 36.05.

General Condition Article 7.14.2 (Alaska Mini-Davis-Bacon Wage Rates) shall apply to all on site work in Napaskiak. Applicable wage rates can be obtained at:

<https://labor.alaska.gov/lss/pamp600.htm>

SC-9.4–CHANGE ORDER

At General Conditions Article 9.4, add the following sentence:

"The AUTHORITY will issue Change Orders for the CONTRACTOR to sign. A Change Order shall be considered executed when the AUTHORITY signs it. The CONTRACTOR'S signature indicates that they accept the Change Order or acknowledge it. Acknowledgement of a Change Order does not surrender the CONTRACTOR'S right to claim."

SC-11.3 – COMPUTATION OF CONTRACT TIME

At General Conditions Article 11.3.3, delete the subsection in its entirety.

SC – 11.5 – EXTENSION DUE TO DELAYS:

At General Conditions Article 11.5, delete paragraph in its entirety and replace with the following:

The right of the CONTRACTOR to proceed shall not be terminated nor the CONTRACTOR charged with liquidated or actual damages because of delays to the completion of the Work due to unforeseeable causes beyond the control and without the fault or negligence of the CONTRACTOR, including, but not restricted to the following: acts of God or of the public enemy, acts of the AUTHORITY in its contractual capacity, acts of another contractor in the performance of a contract with the AUTHORITY, floods, fires, epidemics, quarantine restrictions, strikes, freight embargoes, unusually severe weather, acts or restraints of governmental authorities affecting the project or directly or indirectly prohibiting or restricting the furnishing or use of materials or labor required; inability to secure materials, machinery, equipment or labor because of priority, allocation or other regulations of any governmental authorities, and delays of Subcontractors or Suppliers due to such causes. Any delay in receipt of materials on the site, caused by other than one of the specifically mentioned occurrences above, does not of itself justify a time extension, provided that the CONTRACTOR shall within twenty four (24) hours from the beginning of any such delay (unless the Contracting Officer shall grant a further period of the time prior to the date of final settlement of the Contract), notify the Project Manager in writing of the cause of delay. The Contracting Officer shall ascertain the facts and the extent of the delay and extend the time for completing the Work when the findings of fact justify such an extension.

SC-11.8–DELAY DAMAGES

At General Condition Article 11.8, add the following paragraphs:

11.8.1 For each calendar day that the Work is not Substantially Complete after the Substantial Completion date has passed, the AUTHORITY shall deduct \$500 from progress payments up to a maximum of \$10,000 (20 days).

11.8.2 If no money is due the CONTRACTOR, the AUTHORITY shall have the right to recover these sums from the CONTRACTOR, from the Surety, or from both. These are liquidated damages and not penalties. These charges shall reimburse the AUTHORITY for its additional administrative expenses incurred due to CONTRACTOR'S failure to complete the work within the time specified.

11.8.3 Permitting the CONTRACTOR to continue and finish the work or any part of it after the Contract time has elapsed or the completion date has passed does not waive the AUTHORITY'S rights to collect liquidated damages under this section.

SC-12.1–WARRANTY AND GUARANTEE

At General Condition Article 12.1, add the following sentence:

“The failure of the AUTHORITY to strictly enforce the Contract in one or more instances does not waive its right to do so in other or future instances.”

SC-12.6–CORRECTION OR REMOVAL OF DEFECTIVE WORK

At General Condition Article 12.6, add the following paragraphs:

“The CONTRACTOR shall establish necessary lines and grades before performing the Work. Work done before necessary lines and grades are established, Work contrary to the AUTHORITY’S instructions, Work done beyond the limits of the Contract, or any extra Work done without authority, will be considered as unauthorized and shall not be paid for by the AUTHORITY, and may be ordered removed or replaced at no additional cost to the AUTHORITY.”

SC – 13.5 – STORED MATERIALS AND EQUIPMENT

At General Conditions Article 13.5, add the following;

“No payment will be made for an individual/unique item of material or equipment with a total value less than \$25,000 per item or for any item of material or equipment scheduled for incorporation into the work in less than 60 days from its arrival on site.”

MODIFICATIONS TO THE FEDERAL ASSURANCES 00 90 00

The following supplements modify, change, delete from, or add to Section 00 90 00 "Federal Assurances". Where any Paragraph, Subparagraph, or Clause of the Federal Assurances is modified or deleted by these Supplementary Conditions, the unaltered provisions of that Paragraph, Subparagraph, or Clause shall remain in effect.

SC-90.1–BREACHES AND DISPUTE RESOLUTION

At Federal Assurances Paragraph 90.1 delete the paragraph in its entirety. See General Conditions 00 70 00 Article 15 for Claims and Disputes

SC-90.2 – TERMINATION

At Federal Assurances Paragraph 90.2 delete the paragraph in its entirety. See General Conditions 00 70 00 Article 14 for Suspension of Work and Termination.

SC-90.4–DAVIS-BACON ACT, AS AMENDED

At Federal Assurances Paragraph 90.4 delete the paragraph in its entirety. See Supplemental Conditions 00 80 00 SC-7.14 for prevailing wage rate requirements.

SC-90.13–DOMESTIC PREFERENCES FOR PROCUREMENTS

The Rural Utilities Service Federal funds are exempt from the Buy America Act and therefore this project is not subject to the Buy America Act.

END OF SECTION

**ALASKA ENERGY AUTHORITY
SECTION 00 90 00
FEDERAL ASSURANCES**

Because this contract is funded with federal funds, the following contract provisions shall apply, where applicable, to all work performed on the contract by the contractor's own organization and by subcontractors. As provided in this Section, the contractor shall insert in each subcontract all of the stipulations contained in these Required Contract Provisions and further require their inclusion in any lower tier subcontracts or purchase orders that may in turn be made. The prime contractor shall be responsible for compliance by any subcontractor or lower tier subcontractor with all applicable Required Contract Provisions.

90.1 BREACHES AND DISPUTE RESOLUTION.

Contracts in excess of \$250,000. Any dispute arising under this Contract which is not disposed of by mutual agreement shall be resolved in accordance with 2 AAC 108.915.

90.2 TERMINATION.

Contracts in excess of \$10,000. This Contract may be terminated by either party upon 10 days written notice if the other party fails substantially to perform in accordance with its terms through no fault of the party initiating the termination ("Default Termination"). If the Authority terminates this agreement, the Authority will pay the Contractor a sum equal to the percentage of Work completed that can be substantiated either by the Contractor to the satisfaction of the Authority, or by the Authority. If the Authority becomes aware of any non-conformance with the Work or this agreement by the Contractor, the Authority will promptly notify the Contractor in writing of the non-conformance. Should the Contractor's Work remain in non-conformance after having received written notification, the percentage of total compensation attributable to the non-conforming Work may be withheld. The Authority may at any time suspend or terminate ("Convenience Termination") this Agreement for its needs or convenience with or without cause upon written notice. In the event of a Convenience Termination, the Contractor will be compensated for all authorized Work and authorized expenditures performed to the date of receipt of written notice of termination plus reasonable expenses. No fee or other compensation will be due for any incomplete portion of the Work.

90.3 EQUAL EMPLOYMENT OPPORTUNITY.

Except as otherwise provided under [41 CFR Part 60](#), all construction contracts must include, and all contractors and subcontractors must comply with, the equal opportunity clause provided under [41 CFR 60-1.4\(b\)](#), in accordance with Executive Order 11246, "Equal Employment Opportunity" ([30 FR 12319, 12935, 3 CFR Part, 1964-1965](#) Comp., p. 339), as amended by Executive Order 11375, "Amending Executive Order 11246 Relating to Equal Employment Opportunity," and implementing regulations at [41 CFR part 60](#), "Office of Federal Contract Compliance Programs, Equal Employment Opportunity, Department of Labor."

90.4 DAVIS-BACON ACT, AS AMENDED ([40 U.S.C. 3141-3148](#)).

Construction contracts in excess of \$2,000 are required to comply with the Davis-Bacon Act ([40 U.S.C. 3141-3144](#), and [3146-3148](#)) as supplemented by Department of Labor regulations ([29 CFR Part 5](#), "Labor Standards Provisions Applicable to Contracts Covering Federally Financed and Assisted Construction"). Contractors are required to pay wages to laborers and mechanics at a rate not less than the prevailing wages specified in a wage determination made by the Secretary of Labor. In addition, contractors must

pay wages not less than once a week. **A copy of the current prevailing wage determination issued by the Department of Labor is included in this solicitation.** Contract and subcontract awards must be conditioned upon the acceptance of the wage determination. All suspected or reported violations must be reported to the Federal awarding agency.

90.5 COPELAND “ANTI-KICKBACK” ACT ([40 U.S.C. 3145](#))

Construction contracts in excess of \$2,000 are required to comply with the **Copeland “Anti-Kickback” Act** ([40 U.S.C. 3145](#)), as supplemented by Department of Labor regulations ([29 CFR Part 3](#), “Contractors and Subcontractors on Public Building or Public Work Financed in Whole or in Part by Loans or Grants from the United States”). Each contractor or subrecipient is prohibited from inducing, by any means, any person employed in the construction, completion, or repair of public work, to give up any part of the compensation to which he or she is otherwise entitled. All suspected or reported violations must be reported to the Federal awarding agency.

90.6 CONTRACT WORK HOURS/SAFETY STANDARDS ACT ([40 U.S.C. 3701-3708](#)).

Construction contracts in excess of \$100,000 that involve the employment of mechanics or laborers are required to comply with [40 U.S.C. 3702](#) and [3704](#), as supplemented by Department of Labor regulations ([29 CFR Part 5](#)). Under [40 U.S.C. 3702](#) of the Act, each contractor is required to compute the wages of every mechanic and laborer on the basis of a standard work week of 40 hours. Work in excess of the standard work week is permissible provided that the worker is compensated at a rate of not less than one and a half times the basic rate of pay for all hours worked in excess of 40 hours in the work week. The requirements of [40 U.S.C. 3704](#) are applicable to construction work and provide that no laborer or mechanic must be required to work in surroundings or under working conditions which are unsanitary, hazardous or dangerous. These requirements do not apply to the purchases of supplies or materials or articles ordinarily available on the open market, or contracts for transportation or transmission of intelligence.

90.7 RIGHTS TO INVENTIONS MADE UNDER A CONTRACT OR AGREEMENT.

If the recipient or subrecipient wishes to enter into a contract with a small business firm or nonprofit organization regarding the substitution of parties, assignment or performance of experimental, developmental, or research work under that “funding agreement,” the recipient or subrecipient must comply with the requirements of [37 CFR Part 401](#), “Rights to Inventions Made by Nonprofit Organizations and Small Business Firms Under Government Grants, Contracts and Cooperative Agreements,” and any implementing regulations issued by the awarding agency.

90.8 CLEAN AIR ACT ([42 U.S.C. 7401-7671Q.](#)) AND THE FEDERAL WATER POLLUTION CONTROL ACT ([33 U.S.C. 1251-1387](#)), AS AMENDED

Contracts in excess of \$150,000 are required to comply with all applicable standards, orders or regulations issued pursuant to the Clean Air Act ([42 U.S.C. 7401-7671q](#)) and the Federal Water Pollution Control Act as amended ([33 U.S.C. 1251-1387](#)). Violations must be reported to the Federal awarding agency and the Regional Office of the Environmental Protection Agency (EPA).

90.9 DEBARMENT AND SUSPENSION (EXECUTIVE ORDERS 12549 & 12689)

A contract award **greater than or equal to \$25,000** (see [2 CFR 180.220](#)) must not be made to parties listed on the government wide exclusions in the System for Award Management (SAM), in accordance with the OMB guidelines at [2 CFR 180](#) that implement Executive Orders 12549 (3 CFR part 1986 Comp., p. 189) and 12689 (3 CFR part 1989 Comp., p. 235), “Debarment and Suspension.” **Contractors that**

apply or bid for an award exceeding \$25,000 must sign and submit the attached “Debarment” certification with their bid.

90.10 BYRD ANTI-LOBBYING AMENDMENT ([31 U.S.C. 1352](#))

Each contractor and subcontractor must certify that it will not and has not used Federal appropriated funds to pay any person or organization for influencing or attempting to influence an officer or employee of any agency, a member of Congress, officer or employee of Congress, or an employee of a member of Congress in connection with obtaining any Federal contract, grant or any other award covered by [31 U.S.C. 1352](#). Each tier must also disclose any lobbying with non-Federal funds that takes place in connection with obtaining any Federal award. Disclosures shall be forwarded from tier to tier up to the Authority. **Contractors that apply or bid for an award exceeding \$100,000 must sign and submit the attached “Lobbying” certification with their bid.**

90.11 PROCUREMENT OF RECOVERED MATERIALS.

A state agency or agency of a political subdivision of a state and its contractors must comply with section 6002 of the Solid Waste Disposal Act, as amended by the Resource Conservation and Recovery Act. The requirements of Section 6002 include procuring only items designated in guidelines of the Environmental Protection Agency (EPA) at [40 CFR part 247](#) that contain the highest percentage of recovered materials practicable, consistent with maintaining a satisfactory level of competition, **where the purchase price of the item exceeds \$10,000 or the value of the quantity acquired during the preceding fiscal year exceeded \$10,000**; procuring solid waste management services in a manner that maximizes energy and resource recovery; and establishing an affirmative procurement program for procurement of recovered materials identified in the EPA guidelines.

90.12 PROHIBITION ON CERTAIN TELECOMMUNICATIONS AND VIDEO SURVEILLANCE SERVICES OR EQUIPMENT.

Contractors and subcontractors are prohibited from entering into a contract (or extending or renewing a contract) to procure or obtain equipment, services, or systems that uses covered telecommunications equipment or services as a substantial or essential component of any system, or as critical technology as part of any system. As described in [Public Law 115-232](#), section 889, covered telecommunications equipment is telecommunications equipment produced by Huawei Technologies Company or ZTE Corporation (or any subsidiary or affiliate of such entities). See [§ 200.216](#).

90.13 DOMESTIC PREFERENCES FOR PROCUREMENTS.

As appropriate and to the extent consistent with law, and to the greatest extent practicable, Contractor’s are required to provide a preference for the purchase, acquisition, or use of goods, products, or materials produced in the United States (including but not limited to iron, aluminum, steel, cement, and other manufactured products). The requirements of this section must be included in all contracts and purchase orders for work or products under this award. See [§ 200.322](#).

DEBARMENT, SUSPENSION, INELIGIBILITY & VOLUNTARY EXCLUSION – 2 CFR 200.214; Executive Orders 12549 and 12689 [Applicable to all federally assisted contracts which exceed \$25,000]**Instructions for Certification:**

1. The certification in this clause is a material representation of fact upon which reliance was placed when this transaction was entered into. If it is later determined that the prospective contractor and lower tier participants knowingly rendered an erroneous certification, in addition to other remedies available to the Federal Government, the Authority may pursue available remedies, including suspension and/or debarment.
2. The prospective contractor and lower tier participants shall provide immediate written notice to the Authority if at any time the prospective contractor and lower tier participants learns that its certification was erroneous when submitted or has become erroneous by reason of changed circumstances.
3. The terms "covered transaction," "debarred," "suspended," "ineligible," "lower tier covered transaction," "participant," "persons," "lower tier covered transaction," "principal," "proposal," and voluntarily excluded," as used in this clause, have the meanings set out in the Definitions and Coverage sections of rules implementing Executive Orders [12549](#) and 12689. You may contact the Authority for assistance in obtaining a copy of those regulations.
4. The prospective contractor and lower tier participants agrees by submitting this bid or proposal that, should the proposed covered transaction be entered into, it shall not knowingly enter into any lower tier covered transaction with a person who is debarred, suspended, declared ineligible, or voluntarily excluded from participation in this covered transaction, unless authorized in writing by the Authority.
5. The prospective contractor and lower tier participants further agrees by submitting this bid or proposal that it will require the language of this certification be included in all subcontracts and all lower tier participants shall certify compliance with this requirement.
6. A participant in a covered transaction may rely upon a certification of a prospective participant in a lower tier covered transaction that it is not debarred, suspended, ineligible, or voluntarily excluded from the covered transaction, unless it knows that the certification is erroneous. A participant may decide the method and frequency by which it determines the eligibility of its principals. Each participant may, but is not required to, check the Non-procurement List issued by U.S. General Service Administration.
7. Nothing contained in the foregoing shall be construed to require establishment of system of records in order to render in good faith the certification required by this clause. The knowledge and information of a participant is not required to exceed that which is normally possessed by a prudent person in the ordinary course of business dealings.
8. Except for transactions authorized under Paragraph 5 of these instructions, if a participant in a covered transaction knowingly enters into a lower tier covered transaction with a person who is suspended, debarred, ineligible, or voluntarily excluded from participation in this transaction, in addition to all remedies available to the Federal Government, the Authority may pursue available remedies including suspension and/or debarment.

Certification Regarding Debarment, Suspension, Ineligibility and Voluntary Exclusion Lower Tier Covered Transaction

- (1) The prospective contractor and lower tier participants certifies, by submission of this bid or proposal, that neither it nor its "principals" is presently debarred, suspended, proposed for debarment, declared ineligible, or voluntarily excluded from participation in this transaction by any Federal department or agency.
- (2) When the prospective contractor and lower tier participants is unable to certify to the statements in this certification, such prospective participant shall attach an explanation to this proposal.

The Contractor, _____ certifies or affirms the truthfulness and accuracy of each statement of its certification and disclosure, if any. In addition, the Contractor understands and agrees that the provisions of 2 CFR §180 apply to this certification and disclosure, if any.

Signature of Contractor's Authorized Official: _____

Name and Title of Contractor's Authorized Official: _____

Date: _____

CERTIFICATION REGARDING USE OF CONTRACT FUNDS FOR LOBBYING - 31 USC §1352

[Applicable to all federally assisted contracts and to all related subcontracts which exceed \$100,000]

A bidder must submit to the Authority the below certification with its bid response for any federally assisted contract that exceeds \$100,000. Bids that are not accompanied by a completed certification may be rejected as nonresponsive.

1. The undersigned Contractor certifies, to the best of his or her knowledge and belief, that:
 - a. No Federal appropriated funds have been paid or will be paid, by or on behalf of the undersigned, to any person for influencing or attempting to influence an officer or employee of any Federal agency, a Member of Congress, an officer or employee of Congress, or an employee of a Member of Congress in connection with the awarding of any Federal contract, the making of any Federal grant, the making of any Federal loan, the entering into of any cooperative agreement, and the extension, continuation, renewal, amendment, or modification of any Federal contract, grant, loan, or cooperative agreement.
 - b. If any funds other than Federal appropriated funds have been paid or will be paid to any person for influencing or attempting to influence an officer or employee of any Federal agency, a Member of Congress, an officer or employee of Congress, or an employee of a Member of Congress in connection with this Federal contract, grant, loan, or cooperative agreement, the undersigned shall complete and **submit Standard Form-LLL, "Disclosure Form to Report Lobbying,"** in accordance with its instructions.
2. The undersigned also agrees that he or she shall require that the language of this certification be **included in all lower tier subcontracts, which exceed \$100,000** and that all such recipients shall certify and disclose accordingly.
3. This certification is a material representation of fact upon which reliance was placed when this transaction was made or entered into. Submission of this certification is a prerequisite for making or entering into this transaction imposed by 31 USC 1352 (as amended by the Lobbying Disclosure Act of 1995). Any person who fails to file the required certification shall be subject to a civil penalty of not less than \$10,000 and not more than \$100,000 for each such failure.

The Contractor, _____ certifies or affirms the truthfulness and accuracy of each statement of its certification and disclosure, if any. In addition, the Contractor understands and agrees that the provisions of 31 USC 3801, *et seq.*, apply to this certification and disclosure, if any.

Signature of Contractor's Authorized Official: _____

Name and Title of Contractor's Authorized Official: _____

Date: _____

End of Federal Assurances

SECTION 01 11 13
SUMMARY OF WORK

PART 1 – GENERAL

1.1 REQUIREMENTS INCLUDED

- A. Contract Method.
- B. Work by Others.
- C. Coordination.
- D. Work covered by Contract Documents.

1.2 RELATED REQUIREMENTS:

- A. Section 00 70 00 – General Conditions.
- B. Section 00 80 00 – Supplementary Conditions.
- C. Division 1
- D. Divisions 2 through 33

1.3 CONTRACT METHOD

- A. This Contract is lump sum as shown on the Section 00 32 00 – Bid Schedule. This work shall be measured and paid for in accordance with Section 00 70 00 – General Conditions, Article 13 – Payment to Contractors and Completion and Section 01 29 73 - Schedule of Values.

1.4 WORK BY OTHERS

- A. All work shall be included in this Contract except for tasks specifically indicated as being performed by others.

1.5 COORDINATION

- A. Coordinate Work to assure efficient and orderly sequence of installation.
- B. Prior to procurement, verify that characteristics of interrelated equipment are compatible.
- C. Coordinate space requirements and installation of components. Utilize spaces efficiently to maximize accessibility for other installations, maintenance, and repairs.

1.6 WORK COVERED BY CONTRACT DOCUMENTS

- A. The intent of the Contract is to provide for the construction and completion of every detail of work described in the Contract Documents. The Contractor shall furnish all labor, materials, supervision, equipment, tools, transportation, quality control, and supplies required to complete the work in accordance with the Contract Documents.
- B. The following general requirements apply to the Base Bid and to all Additive Alternates.
 - 1. The local utility provides prime power to the community. Work at the project site shall be coordinated to minimize disruptions to the existing power system. All

outages shall be scheduled in advance with the local utility.

2. Receive Owner Furnished Materials in accordance with Section 01 64 00.
 3. Furnish all other required equipment and materials.
 4. Mobilize all required materials, equipment, tools, supplies, etc. and all required personnel to the project site in Napaskiak, Alaska.
 5. Locate existing buildings, boardwalks, utilities, and other features and lay out work areas.
 6. Provide advance written notice to the Authority in accordance with Section 01 77 00 - Contract Closeout Procedures to schedule substantial completion inspection. Prior to declaring the project substantially complete: perform all required tests of mechanical and electrical systems; submit test reports to the Authority; flush and charge all piping systems; and perform all other tasks required to prepare project for commissioning. Document completion by filling out the Pre-Commissioning Substantial Completion Inspection Checklist and submitting to the Authority. Note that a draft version of the checklist is included at the end of this section. The final checklist will be provided to the Contractor prior to the start of construction.
 7. Provide access for the Authority and the Engineer to the site. Provide on-site transportation, ladders, lifts, etc. for inspection and testing of the work.
 8. Correct all deficiencies noted in the Substantial Completion Inspection punchlist. Provide photographic documentation of corrections to the Authority.
 9. Deliver all materials and equipment taken out of service as a result of demolition to the local storage area designated by the utility.
 10. Upon completion remove all Contractor tools and equipment from the project site, thoroughly clean all work areas, remove all rubbish and debris, and dispose of all waste in accordance with the Contract Documents.
- C. Work under this Contract is defined under Base Bid and Additive Alternates as described in the paragraphs that follow.

1.7 BASE BID DESCRIPTION OF WORK

Provide all work on the Napaskiak Power System Upgrade project except for work specifically indicated on the Drawings as Additive Alternates. Work shall include but not be limited to:

- A. Receive Owner Furnished materials including completed power plant module (module), transformers, and loose ship accessories. See Section 01 64 00 – Receipt of Owner Furnished Materials. Note that at the time of transfer, the module will be fully functional and completely tested with temporary piping and electrical connections as noted on the Drawings.
- B. Disassemble the module as required to prepare for shipping. The Drawings have notes describing points intended to allow disassembly with minimal disruption to equipment and systems. These are provided for guidance only. The Contractor shall be responsible for removal of exterior features and shall cover work as

- required to ensure module systems will not be damaged in shipping.
- C. Drain engine coolant glycol as required and store in sealed drums for shipment with the module. Disconnect all batteries at the engines, emergency lights, fire alarm panel, and switchgear UPS.
 - D. Document that module disassembly and preparation is complete by filling out the Module Shop Break Down Pre-Ship Inspection Checklist and submitting to the Authority. Note that a draft version of the checklist is included at the end of this section. The final checklist will be provided to the Contractor prior to the start of construction.
 - E. Waterproof the module for shipping. Plug or cover all exterior openings and penetrations then cover the entire module with reinforced shrink wrap or a custom fit tarpaulin. The Contractor shall be responsible to ensure that water does not get into the module during shipping and storage.
 - F. Package for shipment all loose ship Owner furnished items and all removed items. The Contractor shall be responsible to protect items from damage and moisture during shipping and storage.
 - G. Furnish all materials and equipment required for all on site construction.
 - H. Ship the module, loose ship items, and all required materials to the project site in Napaskiak, Alaska.
 - I. Temporarily remove sections of fencing and reinstall upon completion.
 - J. Prepare the site including moving and stockpiling debris, moving connex, removing membrane liner, cutting and filling existing sand as required to create a level pad, then proof compacting the pad surface.
 - K. Provide concrete foundations and slabs and place as indicated on the Drawings. Place and secure the module and stairs on the concrete foundations. Reinstall landing, loading dock, and cooler supports on the module. Provide door bottom stops on the landing and loading dock.
 - L. Re-assemble module including all piping and electrical systems. Reconnect batteries. Install ventilation system.
 - M. Provide roof system over module.
 - N. Within two calendar weeks of delivery of the module to the project site, make provisions to provide heat within the control room adequate to maintain minimum 50°F ambient temperature. The control room shall remain heated until the Authority begins testing.
 - O. Two days prior to substantial completion, make provisions to provide heat within the generation room adequate to maintain minimum 50°F ambient temperature. The generation room shall remain heated until the Authority begins testing.
 - P. Provide materials and equipment to modify existing bulk fuel transfer piping and associated electrical systems to serve the new power plant. Maintain fuel supply to the existing power plant until the Authority completes testing.

- Q. Provide H-structure, feeder conduits, and modifications to the electrical distribution to connect to the new power plant and install Owner Furnished step up transformers. Maintain community power from the existing power plant until the Authority completes testing.
- R. Provide grounding grid.
- S. Provide permanent internet service to the new power plant.
- T. Provide notice of Substantial Completion in accordance with Section 01 77 00 – Contract Closeout Procedures. Prior to Substantial Completion inspection the Contractor shall ensure that the Work is complete including but not limited to:
 - 1. All systems are complete and ready for functional testing.
 - 2. All required mechanical and electrical testing such as pressure, phase rotation, continuity, megger, etc. have been completed to the satisfaction of the Authority and the test results have been submitted in writing to the Authority.
 - 3. All station service circuits are powered and have been tested. All motors have been checked for rotation.
 - 4. The coolant piping has been charged with glycol and pressure tested.
 - 5. The day tank and used oil blender have been filled and tested.
 - 6. The Pre-Commissioning Substantial Completion Inspection Checklist has been filled out and submitted in writing to the Authority. Note that a draft version of the Substantial Completion Inspection checklist is included at the end of this section. A final checklist will be provided to the Contractor prior to the start of construction.
- U. Upon substantial completion acceptance, the Authority will functionally test and commission the system. The Contractor shall support the Authority during testing. Support shall include but not limited to:
 - 1. Provide a minimum 100kW portable load bank with all required cables and connectors. Note that the Authority will furnish a second 100kW load bank with cables and connectors at no cost to the Contractor. Connect both load banks to the switchgear feeder breaker and to a 120VAC control power source.
 - 2. Provide technicians on site who are familiar with the mechanical and electrical systems to assist with testing and to make corrections to any deficiencies found in the Work.
- V. Tasks performed by the Authority will include but not be limited to:
 - 1. A complete functional test of the generation system including automatic and manual start/stop, paralleling, load sharing, and safety shut downs.
 - 2. Functional test of all associated systems including fuel, used oil blending, cooling, heat recovery, plant heat, and ventilation.
 - 3. Final verification of calibration of all mechanical and electrical instrumentation devices.
 - 4. Test of all data and communication systems to demonstrate proper operation of

SCADA system including remote internet access.

5. Demonstration of system functions and operations to local power plant operators.
6. Note that a draft version of the Testing and Commissioning checklist is also included at the end of this section.

- W. Upon completion of testing and commissioning the Contractor shall:
1. Perform any punchlist tasks from the Substantial Completion inspection.
 2. De-energize the old power plant and demolish the existing overhead feeder.
 3. Drain the fuel piping from the old plant, blind flange, and secure.
 4. Perform any outstanding Additive Alternate tasks such as heat recovery startup.

1.8 ADDITIVE ALTERNATE #1 (HEAT RECOVERY) DESCRIPTION OF WORK

- A. Perform all heat recovery work specifically indicated on the Drawings as Additive Alternate #1.
- B. Provide all materials and equipment required for the heat recovery system to the end user buildings indicated. Materials shall include but not be limited to: arctic pipe, piping, valves, pumps, equipment, appurtenances, shrouds, hangers, and associated electrical power and control systems.
- C. Provide trenching, backfill, compaction, warning tape, and rigid insulation.
- D. Finish grade the project site and all work areas.
- E. Selectively demolish portions of existing buildings for piping installation and restore to original condition upon completion.
- F. Install all mechanical and electrical systems.
- G. Fill piping mains with propylene glycol, circulate, flush, and purge. Note that this needs to be performed after the power plant has been commissioned and placed on line to provide a heat source.
- H. Flush and purge branch piping and start up heating equipment.
- I. Test all piping, electrical, and controls systems.
- J. Install shrouds, cover exposed work, and finish trim out as required.

1.9 ADDITIVE ALTERNATE #2 (GRAVEL CAP) DESCRIPTION OF WORK

- A. Provide gravel cap driveway and pad as indicated on the Drawings as Additive Alternate #2.
 1. Furnish 100 cubic yards of E1 crushed stone cap delivered to the project site.
 2. Spread gravel uniformly, grade, and compact to 95% density.

1.10 ADDITIVE ALTERNATE #3 (ELECTRICAL DISTRIBUTION) DESCRIPTION OF WORK

- A. Perform all electrical distribution work specifically indicated on the Drawings as Additive Alternate #3.

- B. Maintain prime power in the community with limited outages scheduled in advance with the local utility.

1.11 ADDITIVE ALTERNATE #4 (ELECTRICAL DISTRIBUTION) DESCRIPTION OF WORK

- A. Perform all electrical distribution work specifically indicated on the Drawings as Additive Alternate #4.
- B. Maintain prime power in the community with limited outages scheduled in advance with the local utility.

PART 2 – PRODUCTS (NOT USED)

PART 3 – EXECUTION

PROJECT SCHEDULE CRITICAL DATES

Pre-Bid Meeting	See 001150a Special Notice to Bidders	
Bid Opening	See 00 02 00 Invitation to Bid	
Owner Furnished Module and Loose Ship Items Available for Pickup		May 1, 2024
Owner Furnished Transformers Available for Pickup		May 1, 2024
Base Bid and Additive Alternates #1 & #2 Substantial Completion		November 1, 2024
Base Bid and Additive Alternates #1 & #2 Final Completion		December 1, 2024
Additive Alternates #3 & #4 Substantial Completion		June 1, 2025
Additive Alternates #3 & #4 Final Completion		July 1, 2025

END OF SECTION

**NAPASKIAK ON-SITE CONSTRUCTION
MODULE SHOP BREAK DOWN PRE-SHIPPING INSPECTION CHECKLIST**

Generators	Gen #1	Gen #2	Gen #3
Batteries Secure, Negative Cables Removed & Secured			
Engine Drip Pans, Break-In Oil, & Spare Filters Packed			
Exhaust & Crank Vent Piping Removed & Secured for Shipping			
Exhaust Pipe Insulation Labelled & Packaged for Shipping			
Exhaust Wall Cover Plates & Rockwool Labelled & Packed for Ship			
Charge Air Tubing Cut, Removed, & Secured for Shipping			
Switchgear			
UPS Battery Disconnected			
UPS, Router, Etc. Braced and Secured for Shipping			
Station Service & Control Wiring			
Exterior Devices & Raceways Removed As Required			
Wall Penetrations Taped or Plugged			
Emergency Light Batteries Disconnected and Braced/Secured for Shipping			
Generator Cooling & Heat Recovery (HR) System			
Piping - Coolant & HR Pipes Though Wall Removed & Secured			
Coolant & HR Wall Sleeves Capped/Plugged			
Radiators/CAC's & Structural Supports Packaged & Secured for Shipping			
All Exposed Radiator/CAC Piping Connections Capped or Blind-Flanged			
Radiator/CAC Electrical Disconnected & Secured for Shipping			
Heat Recovery Connections Blind Flanged & Braced/Secured for Shipping			
Glycol Drained As Required and Packed in Sealed Drums Properly Labeled			
Heating & Ventilation			
Three Each Intake Damper Assemblies & Six Filters Packaged For Shipping			
Three Each Roof Intake Ducts Packaged For Shipping			
Three Each Roof Intake Mesh Screens Packaged For Shipping			
Two Each Exterior Exhaust Hoods Packaged For Shipping			
Interior Fuel & Oil Piping			
Piping - Fill & Vent Pipes Though Wall Removed & Secured			
Wall Penetrations Taped or Plugged			
Fire Suppression System			
Exterior Horns & Boxes Removed As Required			
Wall Penetrations Taped or Plugged			
Panel Batteries Disconnected and Braced/Secured for Shipping			
Full Nitrogen Bottle In Rack			
Spare Nitrogen Bottle For Loose Ship			
System Drained & Blown-Out For Shipping			
Module			
Stairs, Loading Dock, Radiator & Cooler Platform Packaged for Shipping			
Module Shop Shipping Preparation Acceptance - Ready to Ship			
Engineer Signature, Printed Name, & Date			
Contractor Signature, Printed Name, & Date			
AEA Staff Signature, Printed Name, & Date			

**NAPASKIAK POWER SYSTEM UPGRADE ON-SITE CONSTRUCTION
PRE-COMMISSIONING SUBSTANTIAL COMPLETION INSPECTION CHECKLIST**

Fuel System & Exterior Piping	
Replacement Filter & Actuated Valve Installation Complete	
New Pipe & Conduit Installation & Supports Complete	
Pipe & Conduit Ready for Cut Over From Old to New Plant	
Piping Pressure Test Reports Complete & Available	
No Leaks or Drips - Pipe Flanges, Valves	
Pipe Coatings Complete	
Verify Actuator Valve Operation	
Heat Recovery System & Arctic Pipe At Module	
Module Wall Entrance Complete, Penetrations Flashed & Sealed	
Jersey Barrier Placed for Arctic Pipe Protection	
Piping Pressure Test Reports Complete & Available	
Feeder & Module Exterior Wiring	
New H-Structure & Transformers Complete	
Overhead Primary Ready for Cut Over From Old to New Plant	
Feeder Conduit Installation & Supports Complete	
Feeder Conduit Wall Penetrations Complete & Sealed	
Feeder Breaker Connected & Rotation Correct	
Module Exterior Alarms, Lighting, Recepts, Etc. Complete & Operational	
Module Exter Radiator & CAC Power/Control Wiring Complete & Operational	
Internet Service Installed and Operational for Commissioning	
Day Tank, Used Oil Hopper & Piping	
Vent Piping & Supports Complete & Secure	
Day Tank Fill Pipe & Conduit Complete & Secure	
Vent & Fuel Piping Finished with Cold Galv	
Vent & Fuel Piping & Conduit Wall Penetrations Flashed and/or Sealed	
Day Tank Full For Commissioning	
Heating & Ventilation	
Intake Ducts & Dampers Installation Complete	
Exhaust Hoods Installation Complete	
Generator Cooling System	
Radiators, Structural Support, & Piping Installation Complete	
Piping Charged With Glycol & Bled	
Glycol Storage Tank Filled & Excess In Sealed Marked Drums	
Coolant Piping Wall Penetrations Cenereted in Sleeves & Sealed	
Coolant & Heat Recovery Pipe Insulation Complete to Wall	
CAC's, Structural Support, & Tubing Installation Complete, Flexes Correct	

**NAPASKIAK POWER SYSTEM UPGRADE ON-SITE CONSTRUCTION
PRE-COMMISSIONING SUBSTANTIAL COMPLETION INSPECTION CHECKLIST**

Charge Air Tube Wall Penetrations Centered in Sleeves & Sealed			
Charge Air Discharge Tube Insulation Complete to Flanges			
Generators	Gen #1	Gen #2	Gen #3
Drip Pan in Place. Spare Filters, Break-In Oil, Tools, Etc. On Site			
Batteries Reconnected			
Exhaust & Crank Vent Piping Installed			
Exhaust Pipe Insulation Installed			
Exhaust Wall Rockwool Insul & Cover Plates Installed & Sealed			
Miscellaneous Power Prior to Commissioning			
Switchgear UPS Battery Reconnected			
Emergency Light Batteries Reconnected			
Ground Bus TEMPORARILY Bonded to Neutral			
Fire Suppression System <i>(Note that this may need to be done after plant commissioning)</i>			
Exterior Devices Reinstalled			
System Filled With Potable Water			
Full Nitrogen Bottle In Rack			
Full Spare Nitrogen Bottle On Site			
Fire Suppression System Field Recertified			
On Site Training Performed			
Substantial Completion Acceptance			
Engineer Signature, Printed Name, & Date			
Contractor Signature, Printed Name, & Date			
AEA Staff Signature, Printed Name, & Date			
Utility Staff Signature, Printed Name, & Date			

**NAPASKIAK POWER SYSTEM UPGRADE ON-SITE CONSTRUCTION
TESTING & COMMISSIONING CHECKLIST**

Step #1 Warm Up Engines & Check		Start Time:	Date:	Outside Temp (F):
<p><u>Status & Prep</u> - With feeder connected to grid verify rotation of distribution system at feeder breaker. Open cutouts at step-up bank and verify power off. Verify temporary neutral to ground jumper is in place. Verify Demand Control temporarily set to 150kW each Gen. Connect minimum 200kW load bank to feeder breaker.</p> <p><u>Manual Warm Up</u> – Place system and each unit in Manual mode and set each unit to Test-Idle. Start and idle each engine for five minutes minimum. Switch each unit to Run-Rated and close breaker to energize bus. Verify switchgear bus rotation. Verify station service power on. Visually check each engine for noise, vibration, leaks, etc. Take each unit off line by pressing the Stop button and allow the engines to cool down and stop.</p>				
Distribution Rotation (A-B-C?)		Switchgear Bus Rotation (A-B-C?)		
Engines Run Good Idle & Rated (Y/N)				
Step #2 Manual Black Start Procedure Test		Start Time:		
<p>Local operators and Utility Manager present for training.</p> <p><u>Status</u> - Identical to Step #1. Set Gen #1 to Lead. Set load bank to 50kW.</p> <p><u>Manual Black Start</u> – Perform Manual Operation black start procedure with all 3 generators (page 2 of Generation Operating Instructions). Verify that all units proportionately share load. Take Gen #1 & Gen #2 off line and run on Gen #3 alone. Open feeder breaker, take Gen #3 off line and allow the engine to cool down and stop</p>				
Generators Running in Parrallel	Gen #1	Gen #2	Gen #3	
Gen #1, Gen #2, & Gen #3 (kW each)				
Generator #3 Running Individually	Gen #1	Gen #2	Gen #3	
Gen #3 (kW)	-----	-----		
Manual Black Start & Stop Successful (Y/N)		Generators Stable Sharing Load (Y/N)		
Step #3 Automatic Black Start Procedure Test		Start Time:		
<p><u>Status</u> - Identical to previous step. (Gen #1 Lead, 50kW Load Bank).</p> <p><u>Automatic Black Start</u> – Perform Automatic Operation black start procedure (page 1 of operating instructions). Verify that Gen #1 is set to Lead. Verify that Gen #2 and #3 shut down.</p>				
Automatic Black Start Successful (Y/N)				
Step #4 Service Due/Oil Change Procedure Test		Start Time:		
<p><u>Status</u> - Identical to previous step (Auto Mode, Gen #1 Lead, 50kW).</p> <p><u>Oil Change</u> – With system running on Gen #1, execute the Oil Change procedure for Gen #1 (page 2 of Generation Operating Instructions). Verify that Gen #2 goes on line and Gen #1 shuts down. Demonstrate how to reset Engine Service Hours but do not reset. Return to normal operation on Gen #1.</p>				
Step #5 Automatic Demand Control Verification		Start Time:		
<p><u>Status</u> - Identical to previous step (Auto Mode, Gen #1 Lead, 50kW).</p> <p><u>Demonstrate Automatic Demand Control</u> – With system running on Gen #1 make changes as listed below and verify that system executes the sequence listed.</p>				
Increase Load Bank to 200 kW, Verify that Gen #2 Parallels with Gen #1				
Change Lead Unit to Gen #3 and Verify that Gen #3 Goes On and Gen #1 Goes Off				
Decrease Load Bank to 100 kW, Verify that Gen #2 Goes Off				
Change Lead Unit to Gen #1 and Verify that Gen #1 Goes On and Gen #3 Goes Off				

**NAPASKIAK POWER SYSTEM UPGRADE ON-SITE CONSTRUCTION
TESTING & COMMISSIONING CHECKLIST**

Step #6 Overall System Testing & Verification Start Time: _____			
<p><u>Status</u> - Identical to end of previous step (Auto Mode, Gen #1 Lead, Gen #1 On Line, 50kW). <u>Module Systems Operation</u> – With system up to full operating temperature, verify operation of thermostatic valve and radiators. After verifying cooling system operation and checking thoroughly for leaks, verify all readings and calibration of temperature sensors and thermometers. Verify day tank fill cycle (manually initiate fill cycle if required). Confirm intermediate tank Evo level monitor reading agrees with gauge. Confirm internet connection and all SCADA system values.</p>			
CAC Correct Rotation - Bypass Mode (Y/N) & VFD Mode (Y/N)	CAC1	CAC2	CAC3
Intake (Charge) Air Temp - Max (Deg F)	CAC1	CAC2	CAC3
CAC VFD Frequency - Max (Hz)	CAC1	CAC2	CAC3
Radiator Correct Rotation - Bypass (Y/N) & VFD Mode (Y/N)	R1	R2	
Radiator Temp - Max Observed (Deg F)	R1	R2	
Radiator VFD Frequency - Max Observed (Hz)	R1	R2	
Coolant Return Temp - Max Observed (Deg F)			
Coolant Level at End of Test (%)			
Verify at least one normal day tank fill cycle. (Y/N)			
Verify SCADA pages display on master OIU and also display the same on the laptop or desktop. (Y/N)			
<u>Verify Internet Communication (if available)</u> – Have a person in Anchorage log on to the SCADA system. Using phone or text obtain confirmation of connection and correct function.			
Step #7 Prepare for System Commissioning Stop Time: _____			
<p><u>Status</u> - Identical to end of previous step (Auto Mode, Gen #1 On Line, 50kW). <u>Shut Down</u> – Reduce the load on the load bank to 0kW. Place all 3 Gens in Manual Mode. On Gen #1 press the Stop button. Allow to cool down and shut off.</p>			
Step #8 Commission New Power Plant Start Time: _____ Date: _____ Outside Temp (F): _____			
<p>Disconnect load banks. Remove temporary neutral to ground jumper. Reset Demand Control to final (350 kW each Gen). Schedule a brief outage. Take old plant off line and open cutouts at old step up transformer bank. Close cutouts at new step-up bank for new module grid connection. Run new plant through Automatic Operation black start procedure and place in service. Observe Demand Control Operation. After system stabilizes in normal operation record Bus kW load, Bus metering data, and Station Service kW load.</p>			
Bus kW	Bus Voltage Phase A	Phase B	Phase C
Station Service kW	Bus Current Phase A	Phase B	Phase C
Steps #1-#8 Complete & Accepted Time: _____ Date: _____ Outside Temp (F): _____			
AEA Staff Signature, Printed Name, & Date			
Utility Staff Signature, Printed Name, & Date			

**NAPASKIAK POWER SYSTEM UPGRADE ON-SITE CONSTRUCTION
HEAT RECOVERY SUBSTANTIAL COMPLETION & STARTUP CHECKLIST**

Buried Arctic Pipe Backfill & Grading Complete	
Boardwalk Crossings Repaired	
Church Underfloor Steel Pipe Adequately Supported, Offsets for Flexibility	
Church Underfloor Steel Pipe Insulation & Jacket Complete & Sealed	
Church Floor Penetrations Repaired & Sealed	
Church Cab Unit Htrs Complete, Hoses & Valves Off	
Church Electrical Complete	
New Office Underfloor Steel Pipe Adequately Supported, Offsets for Flex	
New Office Underfloor Steel Pipe Insulation & Jacket Complete & Sealed	
New Office Unit Heater & Strainer Correct, Unit Heaters Valved Off	
New Office Strainer & Bleed Valves Tagged	
New Office Floor Penetrations Repaired & Sealed	
New Office Cab Unit Htrs Complete, Hoses & Valves Off	
New Office Electrical Complete	
Bingo Underfloor Steel Pipe Adequately Supported, Offsets for Flexibility	
Bingo Underfloor Steel Pipe Insulation & Jacket Complete & Sealed	
Bingo Floor Penetrations Repaired & Sealed	
Bingo Cab Unit Htrs Complete, Hoses & Valves Off	
Bingo Electrical Complete	
Head Start Underfloor Steel Pipe Adequately Supported, Offsets for Flexibility	
Head Start Underfloor Steel Pipe Insulation & Jacket Complete & Sealed	
Head Start Floor Penetrations Repaired & Sealed	
Head Start Cab Unit Htrs Complete, Hoses & Valves Off	
Head Start Electrical Complete	
VPSO Underfloor Steel Pipe Adequately Supported, Offsets for Flexibility	
VPSO Underfloor Steel Pipe Insulation & Jacket Complete & Sealed	
VPSO Floor Penetrations Repaired & Sealed	
VPSO Cab Unit Htrs Complete, Hoses & Valves Off	
VPSO Electrical Complete	
Garage Wall Entrance Complete, Penetrations Flashed & Sealed	
Garage Piping - Circuiting & Valves Correct, Unit Heaters Valved Off	
Garage Bleed Valve Tagged	
Garage Electrical Complete	
Arctic/Exterior Pipe Pressure Test Complete & Report Available	
Expansion Tank ET-2 10 PSIG Pre-Charge	

**NAPASKIAK POWER SYSTEM UPGRADE ON-SITE CONSTRUCTION
HEAT RECOVERY SUBSTANTIAL COMPLETION & STARTUP CHECKLIST**

<i>Note: Prior to filling system generators need to be on line carrying load to provide heat source.</i>	
Fill Arctic Pipe With Propylene Glycol to 20 PSIG Min	
Cycle Pump P-HR1B, Bleed/Purge Air at Module, New Office, & Garage	
Add Propylene Glycol to 20 PSIG Min, Start Pumps P-HR1A & P-HR1B	
Heat to 170F, Add Propylene Glycol to 30 PSIG Min, Circulate 24 Hours	
Stop Pumps P-HR1A & P-HR1B, Clean Strainers in Module & New Office	
Cycle Pump P-HR1B, Bleed/Purge Air at Module, New Office, & Garage	
Start Pumps P-HR1A & P-HR1B	
Open Unit Heater Valves, Cycle Pumps and Bleed Air	
Bleed/Purge Cabinet Unit Heater Hoses & Connect	
After Up To 170F Add Propylene Glycol to 30 PSIG Min	
Check Each End User Building Piping - No Leaks or Drips	
Check Each End User Building Controls - Cycle Pumps & Fans With T'Stat	
Install Cabinet Unit Heater Shrouds, Final Trim Out & Cleanup	
Verify Power Plant Thermometers Calibrated	
Verify Flow, Temp, Pressure Readings on SCADA	
Excess Propylene Glycol in Sealed Drums, Labeled "Propylene"	
Heat Recovery Substantial Completion Acceptance	
Contractor Signature, Printed Name, & Date	
AEA Staff Signature, Printed Name, & Date	
Utility Staff Signature, Printed Name, & Date	

SECTION 01 12 19
CONTRACTOR'S CERTIFICATION OF SUBCONTRACTS

PART 1 – GENERAL

1.1 SECTION INCLUDES

- A. Procedures for preparing, submitting and accepting subcontracts.

1.2 RELATED REQUIREMENTS

- A. Section 00 10 00 – Information to Bidders.
- B. Section 00 43 00 – Subcontractor List.
- C. Section 00 70 00 – General Conditions: Subcontractor Certification and Approval.
- D. Section 00 80 00 – Supplementary Conditions: Subcontract Provisions.
- E. Section 01 33 00 – Submittal Procedures.

1.3 PREPARATION OF CERTIFICATION

- A. Certification Forms: Use forms provided by the Authority.
- B. Contractor shall prepare certification form. Where required, attach additional information to the certification form.
- C. Substitute certification forms will not be considered.

1.4 SUBMITTAL OF CERTIFICATION

- A. The Contractor shall submit certification forms for all subcontractors for review and approval by the Authority.

1.5 CONSIDERATION OF CERTIFICATION

- A. Following receipt of submitted subcontractor certification forms, the Authority will review for the following, at minimum:
 - 1. Completeness of forms and attachments
 - 2. Proper execution (signatures) of forms and attachments
- B. Incomplete or improperly executed subcontractor certification forms will be returned to the Contractor for revision and resubmittal.
- C. Contractor shall remove its subcontractor from the project site until its subcontractor certification form is submitted, reviewed, and approved.
- D. The Authority will not process payments for work performed by a non-certified subcontractor.

1.6 ACKNOWLEDGMENT OF CERTIFICATION

- A. Submittals which have been examined by the Authority and are determined to be complete and properly executed shall be acknowledged as such by the Project Manager's signature.

PART 2 – PRODUCTS (NOT USED)

PART 3 – EXECUTION (NOT USED)

END OF SECTION

Note: The Contractor shall provide this form for ALL subcontractors working on this project. This form is applicable to all projects, including Small Procurement Contracts, and must be completed in full.

PROJECT: Napaskiak RPSU Project On Site Construction PROJ. #: 24078

PRIME CONTRACTOR: _____

Pursuant to the Contract Documents, we hereby stipulate the following concerning the award of Work to the last Subcontractor on the following list:

- | | | | | |
|----|---------------------------------|------|------------------------------|-----------------------------|
| 1. | First Tier Subcontractor: _____ | DBE? | Yes <input type="checkbox"/> | No <input type="checkbox"/> |
| | Second Tier: _____ | DBE? | Yes <input type="checkbox"/> | No <input type="checkbox"/> |
| | Third Tier: _____ | DBE? | Yes <input type="checkbox"/> | No <input type="checkbox"/> |
| | Fourth Tier: _____ | DBE? | Yes <input type="checkbox"/> | No <input type="checkbox"/> |

2. Date of Subcontract: _____

3. Amount of Subcontract: \$ _____

4. Scope of Work: _____

5. Are the following documents kept on file by both the Contractor and the Subcontractor (check the appropriate answer)?

Contract Minimum Wage Schedule	Yes <input type="checkbox"/>	No <input type="checkbox"/>
--------------------------------	------------------------------	-----------------------------

6. Does the Subcontract contain provisions for prompt payment, release of retainage, and interest on late payment and retainage conforming to AS 36.90.210?

Yes No

7. Does the Subcontract specifically bind the Subcontractor to the applicable terms and conditions of the Contract Documents for the benefit of the Authority and does it contain waiver provisions and termination provisions as required by the Contract Documents?

Yes No

8. a. Does the Subcontractor have adequate insurance coverages as specified in the Contract Documents?

Yes No

If not, does the Contractor stipulate that the insurance limits of the Subcontractor are acceptable to the Contractor and that he has notified his insurance carrier of the reduced insurance limits?

Yes No

b. Does the evidence of insurance certify that the policies described thereon comply with all aspects of the insurance requirements for this project?

Yes No

Subcontractor Name: _____

c. Does the evidence of insurance list the Authority as an "Additional Insured" or "Certificate Holder"?

Yes No

d. Does the evidence of insurance commit to providing 30 day written notice of cancellation or reduction of any coverage?

Yes No

e. Insurance Expiration dates:

Comprehensive or Commercial General Liability: _____

Automobile: _____ Workers' Compensation: _____

(Other): _____

9. Copies of the following professional certifications, licenses, and registrations are attached (circle all that apply):

Business License (mandatory)

Contractor License (mandatory)

Land Surveyor's License

Electrical Administrator's License (mandatory for electrical subs)

Mechanical Administrator's License (mandatory for mechanical subs)

Engineer/Architect

Other: _____

10. Exceptions to any of the above are explained as follows: _____

CERTIFICATION (to be completed and signed by PRIME CONTRACTOR): I certify all the above to be true and correct.

Signature: _____

Printed Name: _____

Company: _____

Date: _____

AUTHORITY'S APPROVAL/DISAPPROVAL

The subject subcontract is **APPROVED**. Nothing in this approval should be construed as relieving the Prime Contractor of the responsibility for complete performance of the work or as a waiver of any right of the Approval to reject defective work.

Signature: _____ Date: _____
Project Manager

The subject subcontract is **NOT APPROVED** for the following reasons:

Signature: _____ Date: _____
Project Manager

SECTION 01 26 63
CHANGE PROCEDURES

PART 1 – GENERAL

1.1 RELATED REQUIREMENTS

- A. Section 00 32 00 – Bid Schedule.
- B. Section 00 51 00 – Construction Contract.
- C. Section 00 70 00 – General Conditions.
- D. Section 00 80 00 – Supplementary Conditions.
- E. Section 01 29 73 – Schedule of Values.
- F. Section 01 29 76 – Application for Payment.
- G. Section 01 32 16 – Construction Progress Schedule.
- H. Section 01 73 00 – Execution Requirements.

1.2 SUBMITTALS

- A. Submit the name of the individual authorized to accept changes, and to be responsible for informing others in the Contractor's employ of changes in the Work.
- B. Submit with each price proposal a complete, detailed, itemized cost breakdown defining all impacts on Contract Price and Contract Time, in sufficient detail to fully explain the basis for the proposal.
- C. All change forms shall be provided by the Authority.

1.3 CHANGE AUTHORIZATION

- A. In accordance with Section 00 70 00 – General Conditions, Article 9 Changes, the Authority may authorize changes to the Work. The Authority may authorize changes in one of the following ways:
 - 1. Directive (Section 00 70 00, Article 9.3).
 - 2. Change Order (CO) (Section 00 70 00, Article 9.4).
 - 3. Acceptance of Shop Drawing variations, which have been identified by the Contractor. (Section 00 70 00, Article 9.5).
 - 4. Interim Work Authorization (IWA) (Section 00 70 00, Article 9.10).

1.4 CHANGE PROCEDURES

- A. The Authority may initiate change to the contract by issuing to the Contractor a Request for Proposal (RFP) document. The RFP may include:
 - 1. Change narrative.
 - 2. Supplementary revised drawings, specifications, additional details, or sketches.

3. Other information as deemed appropriate.
- B. The Contractor shall request a change to the contract by submitting to the Authority a written Change Order Request form provided by the Authority. The Authority may respond by rejecting it, or with an RFP to initiate contract change. The Contractor's Change Order Request shall include, at minimum:
1. A description of the proposed change with a statement of the justification of the change.
 2. Statement of the effect of the change on Contract Price and Contract Time.
 3. The information required in Section 00 70 00 – General Conditions, Article 15 Claims and Disputes.
- C. Upon receipt of a Request for Proposal (RFP) from the Authority, the Contractor shall respond with a price proposal. The Contractor shall make every effort to return its price proposal in response to the RFP within the time frame requested by the Authority, but in no event later than 14 calendar days from date the RFP is issued. For work to be performed after the execution of a Change Order, the basis of pricing shall be estimated. For work performed prior to the execution of a Change Order, the pricing shall be based upon documentation of actual incurred costs. The price proposal shall include:
1. A complete, detailed, itemized price breakdown.
 2. For the prime contractor and subcontractors, detailed documentation of costs for direct costs, labor, equipment, consultants, sub-contractor markups, overhead and profit, and other items set forth in General Conditions Section 00 70 00, Article 10.
 3. Other information as required by the Authority.
- D. Upon receipt of pricing response to an RFP, the Authority may execute a change to the contract. The issuance of an RFP or the receipt of pricing response to an RFP shall not obligate the Authority to execute a change to the contract.

1.5 DIRECTIVES

- A. The Authority may issue Directives as per Section 00 70 00 – General Conditions, Article 9.3.

1.6 INTERIM WORK AUTHORIZATIONS (IWA)

- A. The Authority may issue Interim Work Authorizations in accordance with Section 00 70 00 – General Conditions, Article 9.10.

1.7 CHANGE ORDER

- A. Any change in Contract Time, Contract Price, or associated responsibility within the general scope of the Contract, shall be made by Change Order.
- B. The Contractor shall use forms furnished by the Authority for Change Orders.

1.8 CHANGE PRICING AND TIME ANALYSIS

- A. Unless specified elsewhere, Section 00 70 00 – General Conditions, Article 10 shall be applied to the negotiation of all changes to the scope of the contract.
 - 1. Unit Price, when unit prices are contained in the Contract.
 - 2. Mutually acceptable Lump Sum Price, including overhead and profit.
 - 3. Cost of the Work.
- B. UNIT PRICE CHANGE – For unit price CHANGE PROCEDURES, prices shall be determined by multiplying the contractual unit price(s) by the estimated quantities of Work associated with changed scope. Payment will be based on the actual installed quantities. Document actual installed quantities and submit information requested by the Authority on a daily basis for its approval and certification. Refer to Section 00 70 00 – General Conditions, Article 10 for additional requirements.
- C. LUMP SUM PRICE CHANGE – The Contractor and the Authority shall negotiate an equitable price (and time adjustment if appropriate) in good faith. If negotiations do not result in a mutually acceptable lump sum price, the Authority may, at its discretion, direct the Contractor to perform the work under Cost of the Work Change Order.
- D. COST OF THE WORK CHANGE – The Contractor shall document Cost of the Work on forms acceptable to the Authority, and shall submit documented costs to the Authority daily for verification and certification. Cost of the Work pricing proposals shall be supported by invoices for substantiation of purchase and rental costs and with additional data as may be requested by Authority.
- E. Time Analysis: NOT USED.
- F. The Authority shall have the right to audit all records in possession of the Contractor relating to activities covered by the Contractor’s pricing of Contract CHANGE ORDER PROCEDURES, including Cost of the Work pricing, as set forth in Section 00 70 00 – General Conditions. If the Contractor is a joint venture, the right of Authority shall apply collaterally to the same extent to the records of joint venture sponsor, and of each individual joint venture member.

1.9 FORM EXECUTION

- A. Contract forms issued under this section shall be effective the date the Authority’s authorized person signs the form.
- B. For Change Orders, Contractor signature will indicate acceptance of the terms or acknowledgment of order, depending on box checked. Acknowledgment of Change Order does not substitute for notification requirements of Section 00 70 00 – General Conditions, Article 15.1.

1.10 PAYMENT

- A. The Contractor shall promptly revise its Schedule of Values and Application for Payment forms to record each authorized Change Order as a separate line item. For Change Orders, adjust the Contract Price as shown on the Change Order.
- B. The Contractor shall promptly revise and resubmit its progress schedules to reflect any change in Contract Time, including adjustments for other items of Work affected by the change.
- C. Payment for contract changes shall be made only following the execution of Change Orders and the inclusion of the Change Order by reference on the Application for Payment form.
- D. Payment shall not be made for Work authorized via Interim Work Authorization until such work is formalized in a Change Order.

PART 2 – PRODUCTS (NOT USED)

PART 3 – EXECUTION (NOT USED)

END OF SECTION



REQUEST FOR INFORMATION or INTERPRETATION

Project: Napaskiak RPSU Project On Site Construction

R.F.I. Number: _____

From: _____

Date: _____

To: Alaska Energy Authority

A/E Project Number: _____

Contract For: _____

Re:

Specification Section:	Paragraph:	Drawing Reference:	Detail:

Request:

Signed by:

Date:

Response:

Attachments:

Response From:	To:	Date Rec'd:

Signed by:

Date:

Copies: Owner Consultants _____ _____ _____ _____ File



CHANGE ORDER REQUEST (PROPOSAL)

Project: Napaskiak RPSU Project On Site Construction

R.F.I. Number: _____

From: _____

Date: _____

To: Alaska Energy Authority

A/E Project Number: _____

Re: _____

Contract For: _____

This Change Order Request (C.O.R.) contains an itemized quotation for changes in the Contract Sum or Contract Time in response to proposed modifications to the Contract Documents based on Proposal Request No. _____.

Description of Proposed Change:

Attached supporting information from: Subcontractor Supplier _____ _____

Reason For Change:

Does Proposed Change involve a change in Contract Sum? No Yes [Increase] [Decrease] \$ _____
Does Proposed Change involve a change in Contract Time? No Yes [Increase] [Decrease] _____ days.

Attached pages: Proposal Worksheet Summary: _____
 Proposal Worksheet Detail(s): _____

Signed by: _____ Date: _____

Copies: Owner Consultants _____ _____ _____ _____ File

This page is blank intentionally.

Project No.: 24078

Directive No.: 000

Project Name: Napaskiak RPSU Project On Site Construction

Scope of this Directive	
<input type="checkbox"/>	Commencement of Work
<input type="checkbox"/>	Suspension of Work
<input type="checkbox"/>	Contract Non-Conformance
<input type="checkbox"/>	Contract Clarification

Contractor: _____

Address: _____

Directive issued By: _____ Date: _____
Engineer or AEA Project Manager

Receipt Acknowledged By: _____ Date: _____
Contractor's Representative:

This Directive complements, and is used in accordance with the terms and provisions of the above referenced Contract, and shall not serve to authorize a change in Contractual responsibility. If the CONTRACTOR believes that any condition in this document may affect Contract Time, Price, or Requirement the CONTRACTOR shall immediately notify the DEPARTMENT of such condition. Contract Performance is required as follows:

DESCRIPTION

X

If the Contractor believes this Directive will adjust the Contract time or price the Contractor shall provide a Changer Order Request (COR) to the Authority, within 14 calendar days.

SECTION 01 29 73
SCHEDULE OF VALUES

PART 1 – GENERAL

1.1 SECTION INCLUDES

- A. Requirements for preparing and submitting the schedule of values.

1.2 RELATED REQUIREMENTS

- A. Section 00 70 00 – General Conditions.
- B. Section 01 11 13 – Summary of Work.
- C. Section 01 26 63 – Change Procedures.
- D. Section 01 29 76 – Application for Payment.
- E. Section 01 32 16 – Construction Progress Schedule.
- F. Section 01 33 00 – Submittal Procedures.
- G. Section 01 77 00 – Contract Closeout Procedures.

1.3 FORMAT

- A. Form and content must be acceptable to the Authority.
- B. Form shall have a signature block for submission by Contractor and a signature block for approval by the Authority.
- C. Content shall include the following column headings.
 - 1. Pay Item Activity Number.
 - 2. Pay Item Activity Description.
 - 3. Pay Item Activity Dollar Value.
 - 4. Current Percent Complete.
 - 5. Current Dollar Complete.
 - 6. Previous Percent Complete.
 - 7. Previous Dollar Complete.
 - 8. Percent Complete this Period.
 - 9. Dollar Complete this Period.

1.4 CONTENT

- A. List installed value of each activity shown on the submitted and approved Construction Project Schedule.
- B. For items on which payments will be requested for stored products, list sub values for cost of stored products with taxes paid.

- C. Limits for specific line item values shall be as specified below and shall be included on all approved Schedules of Values and Applications for Payment.
 - 1. Mobilization and Demobilization: NOT APPLICABLE
 - 2. Contract Closeout Procedures: Unless specified elsewhere, the assigned values for tasks specified under Contract Closeout Procedures shall be based upon the estimated value of each task. The breakdown shall include separate amounts for the requirements of Final Completion and Final Acceptance, as set forth below:

<u>Contract Price</u>	<u>Value for Final Completion</u>	<u>Value for Final Acceptance</u>
Less than \$200,000	\$2,000	\$2,000
\$200,000 - \$500,000	\$5,000	\$5,000
\$500,001 - \$1,000,000	\$10,000	\$10,000
\$1,000,001 - \$5,000,000	\$20,000	\$20,000
Greater than \$5,000,000	\$30,000	\$30,000

- D. The sum of values listed on the Schedule of Values shall equal total Contract Price.

1.5 A Schedule of Values containing costs for early activities in excess of actual value (“front end loading”) will be rejected by the Authority until the Contractor corrects the deficiency. The Authority shall not be obligated to pay the Contractor until front end loading is eliminated and the Schedule of Values is approved.

1.6 SUBMITTAL

- A. Submit proposed Schedule of Values with updated Construction Project Schedule per specification sections for Summary of Work, Construction Progress Schedule, and Submittals.
- B. Submit Schedule of Values with updated completion percentages sufficiently in advance of each Application for Payment to enable the Authority to resolve differences.

1.7 SUBSTANTIATING DATA

- A. When the Authority requires substantiating information, submit data justifying line item amounts in question.
- B. Provide one copy of data with cover letter for each copy of the Application for Payment. Show application number and date, and line item by number and description.

PART 2 – PRODUCTS (NOT USED)

PART 3 – EXECUTION (NOT USED)

END OF SECTION

SECTION 01 29 76
APPLICATION FOR PAYMENT

PART 1 – GENERAL

1.1 SECTION INCLUDES

- A. Procedures for preparation and submittal of Application for Payment.

1.2 RELATED REQUIREMENTS

- A. Section 00 32 00 – Bid Schedule.
- B. Section 00 70 00 – General Conditions.
- C. Section 00 80 00 – Supplementary Conditions.
- D. Section 01 11 13 – Summary of Work.
- E. Section 01 26 63 – Change Procedures.
- F. Section 01 29 73 – Schedule of Values.
- G. Section 01 32 16 - Construction Progress Schedule
- H. Section 01 77 00 – Contract Closeout Procedures.

1.3 FORMAT

- A. Submit Application for Payment on form approved by the Authority.

1.4 PREPARATION OF APPLICATIONS

- A. Type required information on Application for Payment form acceptable to the Authority.
- B. Execute certification by original signature of authorized officer upon each copy of the Application for Payment.
- C. Show breakdown of costs for each item of the Work on accepted Schedule of Values as specified in Section 01 29 73 – Schedule of Values.
- D. List each authorized Change Order as an extension on continuation sheet, listing Change Order number and dollar amount as for an original item of Work.
- E. Submit Stored Materials Worksheet with every Application for Payment requesting payment for stored materials. Show only direct costs of materials and freight. Submit documentation in accordance with Section 00 70 00 – General Conditions, Article 13.5 Stored Materials and Equipment, for materials shown in column titled “New Material This Pay Request Period.”

1.5 SUBMITTAL PROCEDURES

- A. Submit two originals of each Application for Payment at one-month intervals, or as otherwise agreed upon. Each document shall bear original signature of authorized executive.

- B. Submit with Authority-approved transmittal letter bearing Authority's project number.

1.6 SUBSTANTIATING DATA

- A. When Authority requires substantiating information, submit all requested data justifying line item amounts in question.
- B. Provide one copy of data with cover letter for each copy of Application for Payment. Show Application for Payment number and date, and line item by number and description.

1.7 SUBMITTALS WITH APPLICATION FOR PAYMENT

- A. Submit the following for review sufficiently in advance of Application for Payment to allow detailed review by Authority and resolution of differences.
 - 1. Schedule of Values with updated percentages of completion as required by Section 01 29 73 – Schedule of Values.
- B. Submit the following with each Application for Payment.
 - 1. Updated construction schedule as required by Section 01 32 16 - Construction Progress Schedule.
 - 2. Updated Project Record Documents as required by Section 01 78 39 – Project Record Documents.
 - 3. Letter certifying that all Project Record Documents, including as-built drawings and submittals are current.

1.8 ADDITIONAL REQUIREMENTS FOR FIRST APPLICATION FOR PAYMENT

- A. The first Application for Payment will be processed after the Project Manager has received all of the following:
 - 1. Superintendent Data (Section 00 70 00 – General Conditions, Article 6.2).
 - 2. Progress Schedule (Section 00 70 00 – General Conditions, Paragraph 6.6.1, and Section 01 32 16 - Construction Progress Schedule).
 - 3. Schedule of Values (Section 00 70 00 – General Conditions, Paragraph 6.6.2, and Section 01 29 73 – Schedule of Values).
 - 4. Submittal Schedule (Section 00 70 00 – General Conditions, Paragraph 6.6.2).
 - 5. Safety Representative Designation (Section 00 70 00 – General Conditions, Article 6.18).
 - 6. Building Permits (Section 00 70 00 – General Conditions, Article 7.2).
 - 7. Name of Individual Authorized to Accept Changes (Section 01 26 63 – Change Procedures).
 - 8. Contractor Quality Control Plan (Section 01 45 00 – Quality Control).

9. Freeze Protection Plan (Section 01 51 00 – Construction Facilities).

PART 2 – PRODUCTS (NOT USED)

PART 3 – EXECUTION (NOT USED)

END OF SECTION

SECTION 01 31 19
PROJECT MEETINGS

PART 1 – GENERAL

1.1 SECTION INCLUDES

- A. Requirements for various meetings during the construction project.

1.2 RELATED REQUIREMENTS

- A. Section 01 11 13 – Summary of Work.
- B. Section 01 32 16 - Construction Progress Schedule.
- C. Section 01 33 23 – Shop Drawings, Product Data, and Samples.
- D. Section 01 45 00 – Quality Control.
- E. Section 01 73 00 – Execution Requirements.

1.3 GENERAL REQUIREMENTS

- A. All project meetings will be conducted telephonically unless specifically arranged to be held in person.

1.4 PRECONSTRUCTION CONFERENCES

- B. The Authority will administer preconstruction conference for execution of Contract and exchange of preliminary submittals. Attendance by all key Contractor and Subcontractor personnel is required.
- C. The Authority will document the meeting and distribute minutes within 48-hours of adjournment. Minutes will be typed, reflecting date, list of attendees and in a format to facilitate correction of previous meeting minutes. Distribution will be to all attendees and those affected by discussions or decisions made at meeting.

1.5 PREINSTALLATION CONFERENCES

- A. When required in an individual Specification section, and as shown in the Contractor's quality control plan, or as directed by the Authority, convene a pre-installation conference prior to commencing Work for a specific item.
- B. Require attendance of entities directly affecting, or affected by, Work of the section.
- C. Review conditions of installation, preparation and installation procedures, and coordination with related Work.
- D. Record significant discussions and agreements and disagreements of each conference, and approved schedule. Distribute record of conference to all attendees within 24-hours of adjournment.

1.6 PROGRESS MEETINGS

- A. The Contractor shall attend Progress Meetings when scheduled by the Project Manager or requested by the Contractor. Progress Meetings will be held on a day and time which is mutually convenient to both the Authority and the Contractor.

These meetings shall be documented by the Contractor as well as the Project Manager.

- B. The minimum frequency will be typically one time per week during active construction.
- C. Progress Meeting shall be attended by all key Contractor personnel and, as appropriate, key Subcontractor personnel.
- D. The Contractor shall furnish copies of its updated schedule, per Section 01 32 16 - Construction Progress Schedule, to all attendees of the meeting. This schedule will be reviewed in detail during the meeting and will be used for the coordination of activities by others.
- E. Progress Meetings will be used to review status, schedule, safety, quality, critical items, and other key aspects of the Work.

1.7 SAFETY MEETING

- A. The Contractor shall conduct Safety Meetings as required by its project Safety Program. Safety Meetings shall be documented in the daily work report.
- B. The Contractor shall invite the Authority to attend Safety Meetings.

1.8 OTHER MEETINGS

- A. At various times throughout the duration of the Contract, the Contractor will be required to attend meetings as requested by the Authority. It is anticipated that such meetings will involve coordination with others, project schedule review, problem resolution, change order negotiations, and other topics of mutual importance.

PART 2 – PRODUCTS (NOT USED)

PART 3 – EXECUTION (NOT USED)

END OF SECTION

SECTION 01 32 26
CONSTRUCTION PROGRESS REPORTING

PART 1 – GENERAL

1.1 SECTION INCLUDES

- A. Requirements for submitting reports documenting construction progress.

1.2 RELATED REQUIREMENTS

- A. Section 00 70 00 – General Conditions.
- B. Section 00 80 00 – Supplementary Conditions.
- C. Section 01 11 13 – Summary of Work.
- D. Section 01 31 19 – Project Meetings.
- E. Section 01 32 16 - Construction Progress Schedule.

PART 2 – PRODUCTS (NOT USED)

PART 3 – EXECUTION

3.1 SCHEDULE

- A. A daily work report shall be prepared and submitted by the site Superintendent recording progress, all pertinent daily events, and status of any ongoing issues.
- B. Reports shall be submitted a minimum of one time per week. All daily reports for the week shall be consolidated and submitted no later than noon on the following Monday.
- C. More frequent submission may be required during critical times with multiple time critical tasks.
- D. Daily reports documenting work that will be concealed shall be submitted prior to covering work. Types of work requiring immediate reporting shall include but not be limited to underground installation, work that will be enclosed within building walls, floors, or roofs, and coating systems requiring multiple coats.
- E. Daily reports documenting mandatory tests shall be submitted within 24 hours of test completion. Types of work requiring immediate reporting shall include but not be limited to piping pressure tests and electrical circuit tests.

3.2 CONTENT

Daily reports shall include the following as appropriate:

- A. Summary of general tasks relative to construction progress.
- B. Weather conditions.
- C. A minimum of 4 project photos of the work performed that day unless no new work was performed.
- D. Additional photos shall be submitted as required to document work that will be

- covered or to document mandatory tests.
- E. Additional photos shall be submitted if problematic site conditions are encountered that may result in delays or change of conditions.
 - F. Names and titles of all laborers onsite (daily basis).
 - G. Regular labor hours worked (daily basis).
 - H. Overtime hours worked (as encountered and cumulative).
 - I. Material quantities delivered (daily and cumulative).
 - J. General material management items (daily and cumulative).
 - K. Unsuitable quantities hauled offsite (daily and cumulative).
 - L. Quantities of pay items installed (daily and cumulative).
 - M. Any construction issues resulting in delays (reported day of, as encountered).
 - N. Any equipment issues causing delays (reported day of, as encountered).
 - O. Safety Meetings, topics covered.
 - P. Safety issues and concerns (reported day of, as encountered).
 - Q. Disputes (reported day of, as encountered).
 - R. Any information required or outstanding from the Authority.
 - S. Items that could require a change order (reported day of, as encountered).
 - T. Requests for information (reported day of, as encountered).
 - U. Site characteristics that may warrant a Change In Conditions (reported day of, as encountered).
 - V. Note of any onsite conversation, or communication, where direction is given to the contractor which could incur an added cost owed to the Contractor. Date, Time and name of individual must be reported (reported day of, as encountered).

3.3 DISTRIBUTION OF REPORTS

- A. Distribute copies of updated schedules to Contractor's project site file, to subcontractors, suppliers, Engineer, Authority, and other concerned parties.

END OF SECTION

SECTION 01 33 00
SUBMITTAL PROCEDURES

PART 1 – GENERAL

1.1 SECTION INCLUDES

- A. Procedures for the preparation, tracking, and review of submittals for the project.

1.2 RELATED REQUIREMENTS

- A. Section 00 70 00 – General Requirements.
- B. Section 00 80 00 – Supplementary Conditions.
- C. Section 01 11 13 – Summary of Work.
- D. Section 01 12 19 – Contractor’s Certification of Subcontracts.
- E. Section 01 29 73 – Schedule of Values.
- F. Section 01 29 76 – Application for Payment.
- G. Section 01 32 16 - Construction Progress Schedule.
- H. Section 01 33 23 – Shop Drawings, Product Data, and Samples.
- I. Section 01 45 00 – Quality Control.
- J. Section 01 60 00 – Material and Equipment.
- K. Section 01 73 00 – Execution Requirements.
- L. Section 01 77 00 – Contract Closeout Procedures.
- M. Technical Specifications.
- N. Operations and Maintenance Manuals.
- O. Equipment Installation Data.

1.3 SUBMITTAL TIMELINE

- A. The Preliminary Submittal Register shall be provided to the Authority within two (2) calendar weeks of the contract award.
- B. All Submittals shall be provided to the Authority within six (6) calendar weeks of the contract award.
- C. If Submittals for specific items cannot be provided with 6 weeks the Contractor shall notify the Authority in writing listing the specific item(s) and the proposed date for delivery.

1.4 SUBMITTAL REGISTER

- A. Submit preliminary Submittal Register as required by Section 00 70 00 – General Conditions. In addition to manufacturer’s data and shop drawing submissions, include all submittals required by the Contract Documents in the Submittal Register

- B. Submittal Register shall portray an orderly sequence of submittals, early submittals for long lead-time items, and submittals which require extensive review.
- C. Submittal Register shall be reviewed by the Authority and shall be revised and resubmitted until accepted by the Authority.

1.5 SUBMITTAL PREPARATION

- A. The Contractor shall prepare all submittals as required by the provisions of Section 00 70 00 – General Conditions, Section 00 80 00 – Supplementary Conditions, the technical specifications, and the drawings.
- B. The Contractor shall review submittals for accuracy and completeness prior to submitting.

1.6 SUBMITTAL REQUIREMENTS

- A. Unless otherwise directed in these documents or by Authority, provide each submittal as an electronic portable document format (PDF) file, transmitted via email. If file is too large to be received by Authority via email, provide a download link, deliver in portable USB drive, or as otherwise instructed by Authority.
- B. Submit each submittal with a Submittal Summary form as its face document. Use a Submittal Summary form provided by the Authority, or a substitute approved by the Authority.
- C. Label submittals with a numbering system approved by the Authority. Identify the project by title and Authority's project number; identify Work and product by Specification section and Article number.
- D. Submit items required by individual Specification sections together. Do not mix items specified in different sections in the same submittal. Sequence the submission of submittals to correspond with the approved Submittal Register.
- E. Before the submission of each submittal, the Contractor shall have determined and verified all quantities, dimensions, specified performance criteria, installation requirements, materials, catalog numbers and similar data with respect thereto and reviewed or coordinated each submittal with other submittals and with the requirements of the Work and the Contract Documents, upon which the Contractor shall certify in writing on each submittal that it has made this determination. The failure to review and certify a submittal shall be cause for the Authority to return the submittal without review.
- F. On the submittal, notify the Authority in writing of any deviations from requirements of the Contract Documents.
- G. Organize the submittals into logical groupings to facilitate the processing of related submittals, such as:
 - 1. By Specification Section number. Sequentially number each submittal. Resubmittals shall be identified with the original submittal number followed by a sequential alphabetic suffix.

2. Finishes which involve Authority selection of colors, textures, or patterns.
 3. Items required by the individual Technical Product Specification Sections.
 4. Associated items, which require correlation for efficient function or for installation.
- H. Submit all required color and finish samples in order to receive approval for colors and finishes.

1.7 RESUBMITTALS

- A. Provide complete copies of re-submittals. Do not re-submit partial copies of submittals for incorporation into the Authority's retained submittals from the prior submission.
- B. If drawings, product submittals, samples, mockups, or other required submittals are incomplete or not properly submitted, the Authority will not review the submittal and will return it to the Contractor. The Authority will review a submittal no more than 2 times without additional charge to the Contractor. The Contractor shall pay all review costs associated with more than 2 reviews.

1.8 AUTHORITY REVIEW

- A. The Authority will review submittals and re-submittals, and return submittal comments within 7 calendar days of receipt.
- B. The Authority or authorized agent will receive, review and return submittals to the Contractor with one of the following dispositions noted:
- “Approved” – denotes that the submittal is generally consistent with the requirements of the Contract Documents. A resubmittal is not required.
- “Approved with Corrections Noted” – denotes that the submittal is generally consistent with the requirements of the Contract Documents but only as conditioned by notes and corrections made on the submittal. A resubmittal is not required provided the Contractor understands the review comments and desires no further clarification.
- “Revise and Resubmit” – denotes that revisions are required in the submittal in order for the submittal to be generally consistent with the requirements of the Contract Documents. The Authority will indicate on the returned submittal what revisions are necessary. A resubmittal is required.
- “Rejected” – denotes that the submittal does not meet the requirements of the Contract Documents and shall not be used in the Work. The Authority will indicate on the returned submittal the reasons for its rejection. A resubmittal is required.
- C. Review by the Authority of submittals shall not be construed as a complete check, but will indicate only that the general method of construction and detailing is consistent with the requirements of the Contract Documents. Review of submittals shall not relieve the Contractor of the responsibility for compliance

with the requirements of the Contract Documents or for errors, dimensions, and quantities unless specific exception is requested and approved on the submittal.

- D. The Authority's review shall not extend to the means, methods, techniques, sequences or procedures of construction or to safety precautions or programs incident thereto. The review and approval of a separate item as such will not indicate approval of the assembly in which the item functions.

1.9 DISTRIBUTION

- A. The Contractor shall be responsible for making and distributing any reproductions of approved submittals that it may require for its use.
- B. The Contractor shall perform work in accordance with approved submittals.

PART 2 – PRODUCTS (NOT USED)

PART 3 – EXECUTION (NOT USED)

END OF SECTION

SECTION 01 33 23

SHOP DRAWINGS, PRODUCT DATA, AND SAMPLES

PART 1 – GENERAL

1.1 RELATED REQUIREMENTS

- A. Section 00 70 00 – General Conditions.
- B. Section 01 11 13 – Summary of Work.
- C. Section 01 31 19 – Project Meetings.
- D. Section 01 33 00 – Submittal Procedures.
- E. Section 01 45 00 – Quality Control.
- F. Section 01 60 00 – Material and Equipment.
- G. Section 01 73 00 – Execution Requirements.
- H. Section 01 78 39 – Project Record Documents.
- I. Technical Specifications: Identification of submittal requirements.

1.2 SHOP DRAWINGS

- A. Present in a clear and thorough manner. Label each Shop Drawing with Authority's Project name, Project number and date of submittal. Identify each element of the Shop Drawings by reference to specification section, sheet number and detail, schedule, or Area of Work.
- B. The data shown on the Shop Drawings shall be complete with respect to specified performance and design criteria, materials and similar data to show the Authority materials and equipment the Contractor proposes to provide.
- C. Identify dimensions; show relation to adjacent or critical features or Work or products.
- D. Designation of work “by others”, if shown in submittals, shall mean that work will be responsibility of Contractor rather than subcontractor or supplier who has prepared submittals.
- E. Minimum Sheet Size: 11"x17".

1.3 PRODUCT DATA

- A. Submit only pages which are pertinent; mark each copy of standard printed data to identify pertinent products, referenced to Specification section and Article number. Show reference standards, performance characteristics and capacities; wiring, piping and control diagrams; component parts; finishes; dimensions; and required clearances.
- B. Modify manufacturer's standard schematic drawings and diagrams to supplement standard information and to provide information specifically applicable to the Work. Delete information not applicable.
- C. Submit manufacturer's instructions for storage, preparation, assembly, installation, start-up, adjusting, commissioning, and finishing.

1.4 SAMPLES

- A. Submit full range of manufacturer's standard finishes except when more restrictive requirements are specified, indicating colors, textures and patterns for Authority selection as specified in technical product sections.
- B. Submit samples to illustrate functional characteristics of products, including parts and attachments.
- C. Approved samples which may be used in the Work are indicated in the Specification section.
- D. Samples shall be identified clearly as to material, supplier, pertinent data such as catalog numbers and the use for which they are intended, and otherwise as the Authority may require, to enable the Authority to review the submittal.
- E. Label each sample with identification required for transmittal letter.

PART 2 – PRODUCTS (NOT USED)

PART 3 – EXECUTION (NOT USED)

END OF SECTION

SECTION 01 42 19
REFERENCE STANDARDS

PART 1 – GENERAL

1.1 RELATED SECTION

- A. Section 00 70 00 – General Conditions.

1.2 QUALITY ASSURANCE

- A. For Products or workmanship specified by association, trade, or other technical standards: comply with requirements of the standard, except when more rigid requirements are specified or are required by applicable codes.
- B. Conform to reference standard by date of issue current on date of bid advertisement, unless otherwise stated in the Contract Documents.
- C. Provide copies of standards through the submittal process when required by the Contract Documents. Maintain a copy of each reference standard on site during construction.
- D. Should specified reference standards conflict with Contract Documents, request clarification from the Authority before proceeding. Local code requirements, where more stringent than referenced standards, shall govern.
- E. Neither the contractual relationship, duties, and responsibilities of the parties to the Contract, nor those of the Engineer, shall be altered by the Contract Documents by mention or inference otherwise in any reference document.

1.3 CODES, STANDARDS, AND REGULATORY REQUIREMENTS

- A. All work shall be in accordance with the latest edition of governing Codes, Standards and regulatory requirements, including but are not limited to:
 - 1. International Fire Code (IFC).
 - 2. International Building Code (IBC).
 - 3. National Fire Protection Association (NFPA) NFPA 30 and NFPA 37.
 - 4. National Electrical Code (NEC).
 - 5. National Electrical Safety Code (NESC)
 - 6. Alaska Department of Commerce, Community and Economic Development (DCCED) 12 AAC 32
 - 7. Alaska Department of Commerce, Community and Economic Development (DCCED) 12 AAC 39
 - 8. Alaska Department of Environmental Conservation (ADEC) 18 AAC 75.
 - 9. American National Standards Institute/American Society of Mechanical Engineers (ANSI/ASME).

10. American Petroleum Institute (API).
11. American Society of Testing and Materials (ASTM).
12. American Society of Mechanical Engineers (ASME).
13. American Welding Society (AWS).
14. American Institute of Steel Construction (AISC).
15. Manufacturers Standardization Society of the Valve and Fitting Industry (MSS).
16. Steel Structures Painting Council (SSPC).
17. Occupational Safety and Health Administration (OSHA) 29 CFR 1910.

PART 2 – PRODUCTS (NOT USED)

PART 3 – EXECUTION (NOT USED)

END OF SECTION

SECTION 01 43 10
CONTRACTOR QUALIFICATIONS

PART 1 – GENERAL

1.1 SECTION INCLUDES

- A. Contractor’s technical qualifications to be able to execute the Work in accordance with the Contract Documents.

1.2 RELATED REQUIREMENTS

- A. Section 00 70 00 – General Conditions.
- B. Section 01 33 00 – Submittal Procedures.
- C. Section 01 45 00 - Quality Control.
- D. Technical Specifications: Contractor and Fabricator Qualifications.

1.3 SUBMITTALS

- A. As part of the Submittal process submit evidence of qualifications as required by this section and the Technical Specifications.
- B. The subcontractor list shall designate the party responsible for the portion of Work requiring specific qualifications.

1.4 CONTRACTOR QUALIFICATIONS - GENERAL REQUIREMENTS

- A. The Contractor shall meet all technical requirements of the Contract Documents. The Contractor may use sub-contractors as required to meet the requirements. The Authority may request documentation of all required qualifications after the bid opening and prior to award in order to verify Contractor qualifications.

1.5 CONTRACTOR QUALIFICATIONS - SPECIFIC REQUIREMENTS

- A. In accordance with Alaska statues and regulations, all Electrical work falling under the scope of 12 AAC 32.075 shall be performed under the supervision of an Electrical Administrator with a current license in the State of Alaska in the Unlimited Linework Category.
- B. In accordance with Alaska statues and regulations, all Electrical work falling under the scope of 12 AAC 32.165 shall be performed under the supervision of an Electrical Administrator with a current license in the State of Alaska in the Unlimited Commercial Wiring Category.
- C. In accordance with Alaska statues and regulations, all Mechanical work falling under the scope of 12 AAC 39.212 shall be performed under the supervision of a Mechanical Administrator with a current license in the State of Alaska in the Unlimited Commercial and Industrial Plumbing Category.
- D. Sub-contractors for specialty systems such as fire suppression shall meet the minimum requirements of the technical specifications for that item.

PART 2 – PRODUCTS (NOT USED)

PART 3 – EXECUTION (NOT USED)

END OF SECTION

SECTION 01 45 00
QUALITY CONTROL

PART 1 – GENERAL

1.1 SECTION INCLUDES

- A. Contractor's quality assurance program and control procedures for executing the Work.

1.2 RELATED REQUIREMENTS

- A. Section 00 70 00 – General Conditions.
- B. Section 01 33 00 – Submittal Procedures.
- C. Section 01 33 23 – Shop Drawings, Product Data, and Samples.
- D. Section 01 42 19 – Reference Standards.
- E. Section 01 43 10 - Contractor Qualifications.
- F. Section 01 60 00 – Material and Equipment.
- G. Technical Specifications: Testing and Reporting requirements.

1.3 TEST FORMS

- A. The Contractor shall provide forms for all test required by the Technical Specifications. Tests forms shall include but not be limited to tank and piping pressure test, phase rotation, continuity and insulation, etc.
- B. Upon request the Authority can provide the Contractor forms for common tests.

1.4 GENERAL

- A. The Contractor shall provide and maintain an effective Quality Control Program related to testing and inspection. The Contractor shall perform Quality Control Testing as specified and shall provide copies of all results to the Authority for use in observing contract compliance.
- B. The Contractor's Quality Control Program shall include, but is not limited to: administration, management, supervision, reports, record-keeping, submittals, services of independent testing agencies and labs, and other related services.
- C. Quality Control is the sole responsibility of the Contractor.
- D. Specific Quality Control requirements are included in the Technical Specifications. General Quality Control requirements entail ensuring that all aspects of the Work conform to the technical requirements of the Contract Documents.
- E. The Contractor's Quality Control Program described herein is not intended to limit the Contractor's Quality Control activities, which may be necessary to achieve compliance with the Contract Documents.

1.5 JOB CONDITIONS

- A. Where Specifications require work to be field-tested, timely notice of its readiness for inspection and testing shall be provided to the Authority. The Authority shall have the right to witness all tests. Photos shall be taken to document all tests. Work shall be concealed only upon approval by the Authority.
- B. The results of tests are for use by the Authority to evaluate the acceptability of Work with respect to specified testing requirements. Regardless of the test results, Contractor is solely responsible for quality of workmanship and materials and for compliance with requirements of Contract Documents.
- C. Maintain quality control over sub-contractors, suppliers, manufacturers, products, services, site conditions, and workmanship to produce work of specified quality. Verify applicability and follow all manufacturers' recommendations and instructions for assembly, installation and testing of materials and equipment. In any case where the Contractor believes that such recommendations or instructions are not applicable, the Contractor shall so notify the Authority and state the reasons for the Contractor's determination. The Contractor shall then follow the Authority's written direction on whether to follow manufacturer's recommendations and instructions.
- D. Upon failure of Work which has been tested or inspected, previous acceptance may be withdrawn and Work be subject to removal and replacement with Work in accordance with the Contract Documents, at no cost to the Authority.

1.6 MANUFACTURER'S FIELD SERVICES

- A. Required when technical specifications require the manufacturer or fabricator to provide qualified personnel to observe field conditions, installation, quality of workmanship, and to start, test, and adjust equipment as applicable.
- B. Submit to the Authority the manufacturer or fabricator representative's written reports containing observations and recommendations within one (1) calendar week of manufacturer's field services.

PART 2 – PRODUCTS (NOT USED)

PART 3 – EXECUTION

3.1 GENERAL

- A. The Contractor shall provide full and complete documentation of Quality Control procedures and activities.

3.2 QUALITY CONTROL

- A. The Contractor shall establish the methodology to perform the Contractor's inspection and tests of all items including that of its subcontractors. The Contractor shall ensure conformance to applicable technical specifications and drawings with respect to the materials, Codes, workmanship, storage, installation, construction, finishes, functional performance, and identification. The Contractor shall ensure quality for all construction work performed under this Contract,

including assigned subcontract work. The Contractor shall specifically include surveillance and tests required in the technical specifications.

- B. The Contractor shall coordinate all work requiring Special Inspection, where specified, to ensure full access by Special Inspectors and Quality Assurance testing personnel.
- C. The Contractor shall provide, as a minimum, the following components for all definable features of work:
 - 1. Preparatory Inspection Meeting: Contractor shall schedule and attend a preparatory meeting to review testing procedures a minimum of a week prior to beginning work on any element of Work which has been identified in the Contract Documents to require testing and inspection by the Contractor and Code-required Special Inspection. Subsequent meetings shall be conducted as necessary to ensure continued accuracy of testing and inspection procedures.
 - 2. Document Control: Contractor shall have and follow a procedure for ensuring that all Work is performed in accordance with the following:
 - a. Conformed sets of Contract Drawings and Specifications.
 - b. Contract Change Order documents.
 - c. Approved Submittals.
 - d. Applicable Requests for Information (RFI's) or Design Clarification Verifications (DCVR's).
 - e. Manufacturer's Instruction.
 - 3. In Progress Inspection: Contractor shall perform in-progress inspections as work progresses on the Work which shall include, but not be limited to:
 - a. Examination of the quality of workmanship with respect to Contract Drawings, Technical Specifications and Approved Submittals.
 - b. Review of control testing for compliance with Contract requirements.
 - c. Inspection for use of defective or damaged materials, omissions and dimensional requirements.
 - d. Review of timeliness and scheduling requirements for all tests, retests and eventual approvals.
 - 4. Non-Conformance Procedure: Contractor shall have and follow a procedure for identifying, documenting, tracking, and resolving items in the Work which do not comply with Contract Documents, Specifications, Approved Submittals, or Manufacturer's Instructions. If a quality control test indicates that the tested material does not conform to the requirements of the Contract Documents, the Contractor shall take supplemental tests at the same location from which the non-conforming result was obtained,

after correction of the work, to document conformance with the Contract Documents. Otherwise, the Authority reserves the right to reject materials for which final Quality Control tests indicate non-conformance with the Contract Documents.

5. Code Required Inspection: Contractor shall coordinate and make timely requests for inspections, tests and other activities required by Codes and Regulations as specified.

3.3 RECORD KEEPING

- A. The Contractor shall maintain current Quality Control records, on forms acceptable to the Authority, of all inspections and tests performed. The records shall include factual evidence that the required inspections or tests have been performed, including, but not limited to, the following information for each such test and inspection: Specification reference, date, type and number of inspections or test involved; results of the inspections, tests or retests; the nature of defect, causes for rejection, proposed remedial action, corrective action(s) taken, and similar information related to any re-inspection.
- B. The Contractor shall maintain the following Quality Control records and reports and shall submit to the Authority as required:
 1. The Contractor shall fill out test reports immediately upon completion of each test. Test reports shall be signed and dated and shall include adequate photographs to document test procedure and conditions. Test reports shall be submitted with the daily report for the day of testing.
 2. Inspection Logs: The Contractor shall maintain a daily log of all inspections performed for both Contractor and subcontractor operations. The Inspection Log shall include compliance with shop drawings submittals, identification by Specification section and schedule activity of inspections, tests, and retests conducted, results of inspections and tests, location and nature of defects found, causes for rejection, and remedial or corrective actions taken or proposed. The Inspection Log shall be available for review by the Authority upon request.
 3. Immediate Notification of Deficiencies: Contractor shall provide immediate notification to the Authority whenever a failed or nonconforming test or inspection occurs. This immediate notification shall be followed up with a written report describing the deficiency and a correction plan.

3.4 ORGANIZATION

- A. Staffing Levels: Provide sufficient qualified personnel to monitor the work quality at all times. The scheduling and coordinating of all inspection and testing must match the type and pace of work activity.
 1. In cases where multiple trades, disciplines or subcontractors are on site at the same time, each activity shall be inspected and tested by personnel skilled in that portion of the work.

2. In cases where multiple shifts are employed, the Quality Control staff shall be increased as required to monitor the work on each shift.

3.5 QUALITY SURVEILLANCE BY THE AUTHORITY

- A. All items of materials and equipment shall be subject to surveillance testing and inspection by the Authority at the point of production, manufacture or shipment to determine if the producer, manufacturer or shipper maintains an adequate inspection system which ensures conformance to the applicable specifications and drawings with respect to materials, workmanship, construction, finish, functional performance and identification. In addition, all items or materials, equipment and work in place shall be subject to surveillance testing and inspection by the Authority at the site for the same purposes. Surveillance by the Authority does not relieve the Contractor of performing Quality Control inspections and testing of either onsite or offsite Contractor's or subcontractor's workplace or manufacturing assembly plant.

END OF SECTION

SECTION 01 51 00
CONSTRUCTION FACILITIES

PART 1 – GENERAL

1.1 SECTION INCLUDES

- A. Requirements for furnishing and maintaining construction facilities during the project.

1.2 RELATED REQUIREMENTS

- A. Section 01 11 13 – Summary of Work.
- B. Section 01 29 76 – Application for Payment.
- C. Section 01 73 00 – Execution Requirements.

1.3 TEMPORARY ELECTRICITY

- A. Provide and pay for temporary electrical service including required equipment.
- B. Provide lighting for construction operations.
- C. Provide additional lighting for inspections if requested by Authority or Engineer.

1.4 TEMPORARY HEAT

- A. Provide and pay for heat devices, insulated enclosure, tenting, and heat as required to maintain specified conditions for construction operations; for freeze protection; and to protect equipment, materials, and finishes from damage due to temperature or humidity.

1.5 TEMPORARY VENTILATION

- A. Provide and pay for ventilation of enclosed areas to cure materials, to disperse humidity, to prevent accumulations of dust, fumes, vapors, or gases, and to maintain a safe work environment.

1.6 TEMPORARY WATER SERVICE

- A. Provide and pay for temporary water service as required.

1.7 TEMPORARY SANITARY FACILITIES

- A. Provide and pay for required sanitary facilities and enclosures.

1.8 TEMPORARY TELEPHONE AND INTERNET SERVICE

- A. Provide and pay for telephone and internet service to the project site and/or Contractor field offices. Note that in addition to Contractor's needs there may be additional telephone and internet service requirements for testing, commissioning, and operation of the power plant. See Section 01 11 13 Summary of Work.

1.9 FREEZE PROTECTION

- A. Provide freeze protection for temporary water service piping, batteries, switchgear, control panels, fire suppression, and other components potentially subject to harm.

1.10 PROTECTION OF INSTALLED WORK

- A. Protect installed Work and provide special protection where required and where Work is installed in unsecure areas.
- B. Provide temporary and removable protection for installed Products. Control activity in immediate work area to prevent damage.

1.11 SECURITY

- A. Provide security and facilities to protect Work from unauthorized entry, vandalism, or theft.

1.12 REMOVAL OF UTILITIES AND FACILITIES

- A. Unless required for testing, remove Temporary Construction Facilities, Services, Utilities, and other related items prior to Substantial Completion inspection.
- B. Clean and repair damage caused by installation or use of Temporary Construction Facilities.
- C. Restore permanent facilities used during construction to a 'like new' condition if it was provided by Contract, or the condition the facility was found prior to construction of this project for existing facilities.

1.13 COST RESPONSIBILITY

- A. Unless specifically noted otherwise, the cost of Temporary Construction Facilities and utilities shall be the responsibility of Contractor.

PART 2 – PRODUCTS (NOT USED)

PART 3 – EXECUTION (NOT USED)

END OF SECTION

SECTION 01 60 00
MATERIAL AND EQUIPMENT

PART 1 – GENERAL

1.1 SECTION INCLUDES

- A. Requirements for transportation and handling, storage and protection, substitutions, and product options.

1.2 RELATED REQUIREMENTS

- A. Section 00 70 00 – General Conditions.
- B. Section 01 11 13 – Summary of Work.
- C. Section 01 33 00 – Submittal Procedures.
- D. Section 01 33 23 – Shop Drawings, Product Data, and Samples.
- E. Section 01 42 19 – Reference Standards.
- F. Section 01 45 00 – Quality Control.
- G. Section 01 51 00 – Construction Facilities.
- H. Section 01 73 00 – Execution Requirements.

1.3 TRANSPORTATION AND HANDLING

- A. Transport products by methods to avoid product damage; deliver in dry, undamaged condition, in manufacturer's unopened containers or packaging.
- B. Provide equipment and personnel to handle products by methods to prevent soiling or damage.
- C. Immediately on delivery, inspect shipment to assure:
 - 1. Product complies with requirements of Contract Documents and reviewed submittals.
 - 2. Quantities are correct.
 - 3. Accessories and installation hardware are correct.
 - 4. Containers and packages are intact and labels legible.
 - 5. Products are protected and undamaged.

1.4 STORAGE AND PROTECTION

- A. Handle and store materials for construction, products of demolition, and other items to avoid damage to existing buildings, and infrastructure.
- B. Store products in accordance with manufacturer's instructions, with seals and labels intact and legible. Store sensitive products in weather tight enclosures; maintain within temperature and humidity ranges required by manufacturer's instructions.

- C. For exterior storage of fabricated products, place on sloped supports above ground. Cover products subject to deterioration with impervious sheet covering; provide ventilation to avoid condensation.
- D. Store loose granular materials on solid surfaces in a well-drained area; prevent mixing with foreign matter. Cover such material to prevent material from being blown or transported away from the stockpile.
- E. Arrange storage to provide access for inspection. Periodically inspect to assure products are undamaged, and are maintained under required conditions.

1.5 SUBSTITUTIONS

- A. Prior to the bid opening, the Bidder shall make his own determination in selecting which specified or substitute equipment to base his proposal upon. Substituted items shall be equal to or better than that specified or indicated in regard to quality, workmanship, finish, space requirements, mechanical and electrical requirements, performance, and warranties.
- B. After the bid opening, the Contractor shall submit sufficient data in accordance with this Section to establish equality. The Authority shall be the sole judge of equality and acceptability.
- C. Acceptance of substitute materials will not relieve the Contractor of the responsibility for any changes in his own Work or in the Work of other crafts caused by the substitution. Any additional costs resulting from substitutions are the responsibility of the Contractor.
- D. Only one request for substitution will be considered for each product. When substitution is not accepted, provide specified product.
- E. The Authority will consider requests for Substitutions only within 28 days after date established by the Notice to Proceed.
- F. Substitutions may be considered when a Product becomes unavailable through no fault of the Contractor.
- G. Document each request with complete data substantiating compatibility of proposed Substitution with Contract Documents.
- H. Substitutions will not be considered when they are indicated or implied on shop drawing or product data submittals, without separate written request, or when acceptance will require revision to the Contract Documents.

1.6 SUBSTITUTION SUBMITTAL PROCEDURE:

- A. Submit Request for Substitution for consideration on Substitution Request Form provided by the Authority (Section 01 60 00-A). Limit each request to one proposed Substitution.
- B. Submit certification signed by the Contractor, that the Contractor:

1. Has investigated proposed Product and determined that it meets or exceeds the quality level of the specified Product. List similar projects using proposed product, dates of installation and user telephone number.
 2. Will provide an equivalent warranty for the Substitution as for the specified Product.
 3. Will coordinate installation and make changes to other Work, which may be required for the Work to be complete with no additional cost to the Authority.
 4. Waives claims for additional costs or time extension, which may subsequently become apparent from indirect costs.
 5. Will reimburse the Authority for review or redesign services associated with re-approval by Authorities.
- C. Submit shop drawings, manufacturers' product data, and certified test results attesting to the proposed Product equivalence and variations between substitute and specified product. The burden of proof is on proposer.
- D. The Authority will notify the Contractor in writing of decision to accept or reject request.

PART 2 – PRODUCTS

2.1 PRODUCTS

- A. Products include material, equipment, and systems.
- B. Comply with Specifications and referenced standards as minimum requirements.
- C. Components required to be supplied in quantity within a Specification section shall be the same, and shall be interchangeable.
- D. Do not use materials and equipment removed from existing structure, except as specifically required, or allowed, by Contract Documents.

2.2 PRODUCT OPTIONS

- A. Products Specified by Reference Standards or by Description Only: Any Product meeting those standards or description.
- B. Products Specified by Naming One or More Manufacturers followed by the term "No Substitutions": use only specified manufacturers, no substitutions allowed.
- C. Products Specified by Naming One or More Manufacturers with a Provision for Substitutions: Submit a request for substitution for any manufacturer not specifically named that meets the description specifications of the named manufacturers, equal in substance, function, dimension, appearance, and quality.

PART 3 – EXECUTION (NOT USED)

END OF SECTION



Project: Napaskiak RPSU Project On Site Construction

Project No.: 24078

Contractor: _____

Specified item for which substitution is requested: _____
(reference specification section and paragraph)

The following product is submitted for substitution: _____
(describe proposed substitution and differences from specified item; attach complete technical, performance, and test data; state whether substitution affects dimensions and functional clearances shown on drawings or affects other trades, and include complete information for changes to drawings and/or specifications which proposed substitution will require for its proper installation.)

I certify the following:

- | | | |
|--------------------------|--------------------------|--|
| Yes | No | |
| <input type="checkbox"/> | <input type="checkbox"/> | The substitute will perform adequately and achieve the results called for by the general design. |
| <input type="checkbox"/> | <input type="checkbox"/> | The substitute is similar, of equal substance, suited to the same use, and will provide the same warranty as the product specified. |
| <input type="checkbox"/> | <input type="checkbox"/> | An equivalent source of replacement parts is available. |
| <input type="checkbox"/> | <input type="checkbox"/> | The evaluation and approval of the proposed substitute will not delay the Substantial or Final Completion of the project. |
| <input type="checkbox"/> | <input type="checkbox"/> | Any change in the design necessitated by the proposed substitution will not delay the Substantial or Final Completion of the project. |
| <input type="checkbox"/> | <input type="checkbox"/> | The cost of any change in the design necessitated by the proposed substitution, including engineering and detailing costs, and construction costs caused by the substitution will be paid by the Contractor at no cost to the Authority. |
| <input type="checkbox"/> | <input type="checkbox"/> | The cost of any license fee or royalty necessitated by the proposed substitution will be paid by the Contractor at no cost to the Authority. |

The undersigned states that the function, appearance and quality are equivalent or superior to the specified item.

Signed: _____ Date: _____
Authorized Contractor Signature

Architect/Engineer Recommendation:

- Accepted Accepted as Noted Not Accepted Received Too Late

Remarks:

Signed: _____ Date: _____
Architect/Engineer

Accepted
 Rejected
_____ Date: _____
Project Manager

SECTION 01 64 00
RECEIPT OF OWNER FURNISHED MATERIALS

PART 1 – GENERAL

1.1 SECTION INCLUDES

- A. This section describes receipt, unloading, transportation, storage, and handling of materials furnished by the Owner (Authority) for this project as described herein.
- B. See Section 01 11 13 – Summary of Work for delivery dates for Owner Furnished materials.

1.2 RELATED REQUIREMENT

- A. Section 01 11 13 – Summary of Work.

1.3 DESCRIPTION OF OWNER FURNISHED MATERIAL

- A. Modular Power Plant: One (1) each steel modular power plant. The module was constructed and tested by others under a separate contract as detailed on the Drawings. The module will be fully assembled, functionally tested, and approved by the Authority prior to transfer to the Contractor. The overall module dimensions are 47' long by 17' wide by 14' high and the total weight is estimated to be 90,000#. The module will be staged at Mechanical Builders, Inc., 2080 Eklutna Street, Palmer Alaska 99645. The Contractor will make arrangements with the Authority to receive the module at this location and take possession.
- B. Modular Power Plant Loose Ship Accessories: One (1) each fabricated steel stair assembly, one (1) each fabricated loading dock assembly, one (1) each fabricated radiator support assembly, one (1) each fabricated charge air cooler support assembly, four (4) each foundation anchor assemblies, three (3) each exhaust hoods, four (4) each intake duct systems, and one lot miscellaneous items such as filters, boxes of small parts, drums of glycol solution, etc. The loose ship items will be staged with the module at Mechanical Builders, Inc., 2080 Eklutna Street, Palmer Alaska 99645. The Contractor will make arrangements with the Authority to receive the items at this location and take possession.
- C. Distribution Transformers: Thirty four (34) each pole mount transformers strapped to pallets. The transformers will be staged at the Alaska Energy Authority Warehouse, 2601 Commercial Drive, Anchorage Alaska 99501. The Contractor will make arrangements with the Authority to receive the items at this location and take possession.

1.4 ACCEPTANCE OF OWNER FURNISHED MATERIAL

- A. The Contractor shall (1) receive and accept the materials at the staging location specified; (2) inspect all materials to confirm that the materials delivered are in good condition and the quantities are correct; and (3) execute a receipt for all materials accepted from the Authority. Delinquency in signing material receipts may result in delayed progress payments.

- B. All material furnished by the Authority shall comply with the plans and specifications. All materials which do not meet specifications or are received broken or damaged shall be culled by the Contractor and a report made to the Authority within 5 days of receipt of material as to the number culled and reason for culling.
- C. If the Authority fails to deliver the materials according to the dates set forth in Section 01 11 13 – Summary of Work, the Contractor's sole remedy and compensation shall be an extension of time not greater than the delay. Any such time extension shall be requested in writing by the Contractor.

1.5 RECEIPT, TRANSPORTING AND STORING OWNER FURNISHED MATERIAL

- A. The Contractor shall receive, transport, and protect all material in accordance with accepted industry standards.
- B. All handling charges required for receiving, loading, unloading, hauling, transporting or storing the material shall be provided by the Contractor.
- C. Any demurrage charges or other fees incurred as a result of the Contractor not receiving, moving and storing the material shall be paid by the Contractor. If the Authority is required to pay these fees, the fees will be deducted from the first Contractor pay request.
- D. The Contractor shall provide proper equipment as necessary to load, unload, and transport Owner furnished material. The equipment shall be rated as required to properly handle the material.

1.6 DAMAGE TO OWNER FURNISHED MATERIAL

- A. Upon receipt of the materials as specified above, the Contractor shall become solely responsible for their care, transportation, storage, and protection. In the event materials are damaged, lost, stolen, or destroyed by any cause whatsoever after the Contractor has signed a receipt for them, their repair or replacement shall be entirely at the Contractor's expense.
- B. All material replaced by the Contractor shall be equal to the material provided by the Authority and shall meet the material purchase specifications.

1.7 STORAGE OF OWNER FURNISHED MATERIAL

- A. The Contractor shall provide secure storage for all Authority furnished material and shall be responsible for transporting the material to the jobsite as required to support the construction schedule.

PART 2 – PRODUCTS (NOT USED)

PART 3 – EXECUTION (NOT USED)

END OF SECTION

SECTION 01 71 13
MOBILIZATION AND DEMOBILIZATION

PART 1 – GENERAL

1.1 SECTION INCLUDES

- A. Requirements for mobilization and demobilization.

1.2 RELATED REQUIREMENTS

- A. Section 01 11 13 – Summary of Work.
- B. Section 01 29 73 – Schedule of Values.
- C. Section 01 29 76 – Application for Payment.
- D. Section 01 51 00 – Construction Facilities.
- E. Section 01 77 00 – Contract Closeout Procedures.

1.3 DEFINITIONS

- A. Mobilization and Demobilization includes:
 - 1. Travel to the project site of all personnel, including sub-contractors, and return upon completion of the Work.
 - 2. Delivery to the Site of all construction equipment, tools, supplies, temporary facilities, etc. ready for commencing and prosecuting the Work, and the subsequent removal from the site upon completion of the Work.
 - 3. Delivery to the Site of all required project materials, including Owner Furnished Equipment. Removal of any leftover materials from the site upon completion of the Work. Note that with agreement of the Owner, leftover materials may be left on the project site if placed in a neat and orderly fashion at a location approved by the Owner.
 - 4. The preparation of the Contractor's work area; the complete assembly of equipment necessary to perform the required work; and all other preparatory work required to permit commencement of the actual Work.

1.4 REQUIREMENTS

- A. Haul routes, staging areas, and equipment positioning at the project site will be subject to approval by Authority, who will coordinate with Contractor to determine requirements and locations.
- B. Cooperate with Authority in allocation and use of Mobilization and Demobilization areas of Site, field offices and sheds, materials storage, traffic, and parking facilities.
- C. During construction, coordinate use of Site and facilities through the Authority.

- D. Comply with Authority's procedures of contract communications; submittals, reports and records, schedules, coordination drawings, and recommendations; and resolution of ambiguities and conflicts.
- E. Comply with instructions of Authority for use of utilities and construction facilities.
- F. Coordinate field engineering and layout Work under instructions of Authority.
- G. Walk through Site with Authority prior to start of Work.

1.5 SUBMITTALS

- A. Refer to Section 01 33 00 – Submittal Procedures, for submittal requirements.
- B. If requested by Authority, submit a plan of the proposed layout of the construction site, including equipment, access ways, temporary facilities, staging, and storage areas, within four (4) calendar weeks after Notice to Proceed.

PART 2 – PRODUCTS (NOT USED)

PART 3 – EXECUTION

3.1 EXECUTION REQUIREMENTS

- A. Delivery to the jobsite of construction tools, equipment, materials, and supplies shall be accomplished in conformance with applicable ordinances, regulations, and the requirements of the Contract Documents.
- B. Upon completion of the Work, remove construction tools, apparatus, equipment, unused materials and supplies, and personnel from the jobsite.

END OF SECTION

SECTION 01 71 23.16
CONSTRUCTION SURVEYING

PART 1 – GENERAL

1.1 SECTION INCLUDES

- A. Construction surveying requirements.

1.2 RELATED REQUIREMENTS

- A. Electronic survey data is available to the contractor upon request.
- B. Section 01 33 00 – Submittal Procedures.

1.3 SUBMITTALS

- A. Upon request of the Authority, submit copies of all field notes and survey data.
- B. Provide marked-up as-built drawings.

PART 2 – PRODUCTS

2.1 SURVEY MATERIALS

- A. Provide all construction surveying and staking materials to stake construction work.

PART 3 – EXECUTION

3.1 SURVEYING BY ENGINEER

- A. No surveying will be provided by the Engineer.

3.2 CONTRACTOR RESPONSIBILITIES

- A. Contractor shall set all lines and grades by instrument survey in order to correctly layout the following:
 - 1. Building foundation.
 - 2. Pipelines, powerlines, and other similar utilities.
 - 3. All other Construction.
- B. Contractor shall provide and pay for all surveying as required for project completion and acceptance.
- C. Contractor shall provide vertical and horizontal as-built locations of buried utilities.
- D. Contractor shall locate and protect all survey reference points. Contractor shall have a Professional Land Surveyor, licensed in the State of Alaska, reset any survey points that have been disturbed at Contractor's expense.
- E. Grades shall be tied to the basis of vertical control indicated on the Drawings.
- F. Field-adjust grades to meet the minimum fill depth required by the Drawings.

3.3 ACCURACY AND TOLERANCES

- A. Contractor's surveys shall be subject to the following tolerances, unless another tolerance is specified elsewhere in the Contract Documents:
 - 1. Building Foundation: $\pm 1/4$ -inch in 10 foot.
 - 2. All other Construction:
 - a. ± 0.10 feet horizontally.
 - b. ± 0.10 feet vertically.

3.4 RECORDS

- A. Maintain a complete, accurate, and reduced set of field notes of all survey work and submit all notes to the Authority at the conclusion of work and as requested.

END OF SECTION

SECTION 01 73 00
EXECUTION REQUIREMENTS

PART 1 – GENERAL

1.1 SECTION INCLUDES

- A. Requirements for addressing defects, cleaning, operating and maintenance manuals, spare parts, training, warranties and bonds, and maintenance service.

1.2 RELATED REQUIREMENTS

- A. Section 00 70 00 – General Conditions: Fiscal provisions, legal submittals, and other administrative requirements.
- B. Section 01 26 63 – Change Procedures.
- C. Section 01 31 19 – Project Meetings.
- D. Section 01 33 00 – Submittal Procedures.
- E. Section 01 33 23 – Shop Drawings, Product Data, and Samples.
- F. Section 01 60 00 – Material and Equipment.
- G. Section 01 74 00 – Cleaning and Waste Management.

1.3 CLOSEOUT PROCEDURES

- A. Comply with Section 01 77 00 - Contract Closeout Procedures.

1.4 DEFECTS

- A. Product defects shall be all items that affect the visual appearance or function of the Products. Defects shall be as identified below unless more stringent requirements are specified within specific sections.
- B. Products shall typically be viewed from a distance of 30.0 inches (760 mm).
- C. Defects shall be solely determined by the Authority.
- D. Defects, Product:
 - 1. Cuts, Scrapes, Gouges Abrasions 0.250 inch (6 mm) long or longer, and 0.03125 inches (0.79375 mm) wide or wider that are visible at a distance of 30.0 inches (762 mm) shall be considered defects.
 - 2. Abrasions less than the above shall be accepted.
 - 3. Burns of any size that permanently discolor the surface material shall be considered defects.
 - 4. Product color variation.
- E. Defects, Joint:
 - 1. Non-alignment of Products. Visual defects and non-alignment of joints shall be considered defective.
- F. Defects, Structural:

1. Bent members or other structural damage shall be considered defective.
 2. Incorrectly manufactured members shall be considered defective.
- G. Defects, Corrosion:
1. Surface corrosion not exceeding one percent (1%) of the surface area shall be considered a visual defect.
 2. Surface corrosion exceeding one percent (1%) and not exceeding five percent (5%) of the surface area shall be evaluated by the Authority to determine defect type.
 3. Surface corrosion exceeding five percent (5%) of the surface area shall be considered a structural defect.
- H. Defects shall be repaired or replaced at no additional cost to the Authority.
1. Structural defects shall be replaced, no exceptions.
 2. Visual defects shall be repaired or replaced as solely determined by the Authority.

1.5 PROGRESS CLEANING AND WASTE REMOVAL

- A. Maintain work and storage areas free of waste materials, debris, and rubbish. Maintain site in a neat and orderly condition to maintain safe passage and exits and to avoid fire and tripping hazards. Provide covered containers for deposit of waste materials.
- B. Collect and remove waste materials, debris, and rubbish from site periodically and at least weekly, and dispose off-site. Have equipment and personnel available on-site daily to sweep and clean work sites and interior work areas.
- C. Comply with Section 01 74 00 – Cleaning and Waste Management.

1.6 FINAL CLEANING

- A. Execute final cleaning prior to Substantial Completion inspection.
- B. Clean interior and exterior surfaces exposed to view; remove temporary labels, stains and foreign substances.
- C. Use materials which will not create hazards to health or property, and which will not damage surfaces. Follow manufacturer's recommendations.
- D. Maintain cleaning until the Authority issues certificate of Substantial Completion.
- E. Remove waste, debris and surplus materials from site. Clean work site and interior work areas; remove stains, spills, and foreign substances from all areas and sweep clean. Rake clean work site. Comply with Section 01 74 00 – Cleaning and Waste Management.

1.7 ADJUSTING

- A. Adjust operating Products and equipment to ensure smooth and unhindered operation.

1.8 OPERATION AND MAINTENANCE (O&M) DATA

- A. Provide Operation and Maintenance Manuals for specific equipment as described in the Technical Specifications. For this project O&M Manuals are only required for the engine-generators, the switchgear, and the fire suppression system.
- B. Unless otherwise directed in these documents or by the Authority, provide each submittal as an electronic portable document format (PDF) file, transmitted via email. If file is too large to be received by the Authority via email, provide a download link, deliver in portable USB drive, or as otherwise instructed by the Authority

1.9 TRAINING

- A. Before Substantial Completion, instruct the local operator(s) and Authority's designated personnel in operation, adjustment, and maintenance of products, equipment, and systems, at agreed upon times.

1.10 SPARE PARTS AND MAINTENANCE PRODUCTS

- A. Provide spare parts, maintenance, and extra products in quantities specified in the Technical Specifications. These shall be labeled and stored per manufacturer's recommendations and as specified.
- B. Deliver to Project site and place in location as directed; obtain receipt prior to Substantial Completion payment.

1.11 WARRANTIES AND BONDS

- A. Provide duplicate notarized copies.
- B. Execute and assemble transferable warranty documents from Subcontractors, suppliers, and manufacturers.

- C. Provide Table of Contents and assemble in three D side ring binder with durable plastic cover.
- D. For items of Work delayed beyond date of Substantial Completion, provide updated submittal within 10 days after acceptance, listing date of acceptance as start of warranty period.

PART 2 – PRODUCTS (NOT USED)

PART 3 – EXECUTION (NOT USED)

END OF SECTION

SECTION 01 74 00
CLEANING AND WASTE MANAGEMENT

PART 1 – GENERAL

1.1 GENERAL

- A. During the term of this Contract, the Contractor shall remove as promptly as possible any materials and equipment which are not required for the completion of the Work. All debris shall be removed from the site and disposed of daily. The Contractor shall take particular care to eliminate any hazards created by these operations.
- B. All cleaning shall be performed to the satisfaction of and at no additional cost to the Authority.

1.2 RELATED REQUIREMENTS

- A. Section 01 73 00 – Execution Requirements.

PART 2 – PRODUCTS (NOT USED)

PART 3 – EXECUTION

3.1 PROGRESS CLEANING

- A. At the completion of the project, or prior thereto if so directed by the Authority, the Contractor shall be responsible for completely cleaning those portions of the project which his work affects.
- B. Contractor shall remove from the facility all tools, equipment, surplus materials, temporary structures, and other material not incorporated in the permanent installation.
- C. Restoration of Damaged Property: To the extent that any roads, vegetation, structures, utilities, or other items are damaged or displaced by the Contractor's operations, these shall be restored to their original or better condition prior to Substantial Completion inspection. This shall include both on-site and off-site items. Any damage which is severe enough to disrupt community travel or utilities shall be repaired by the Contractor immediately.
- D. General cleaning and restoration must be accomplished prior to Substantial Completion.
- E. Final cleaning and restoration must be accomplished prior to Final Completion.
- F. Disposal of hazardous and construction materials shall be accomplished as specified in Section 00 70 00 – General Conditions and this Section.

3.2 WASTE DISPOSAL

- A. Salvaged Material: All salvaged items not being reinstalled shall be turned over to the Owner or Utility as indicated in the Drawings.
- B. General Construction Waste: Waste generated during the process of completing the

project scope of work shall be removed from the limits of the project site and disposed of. All general construction waste shall be disposed of as required by local, state and federal laws, rules, regulations and requirements.

END OF SECTION

SECTION 01 77 00
CONTRACT CLOSEOUT PROCEDURES

PART 1 – GENERAL

1.1 SECTION INCLUDES

- A. Requirements for Substantial Completion.
- B. Requirements for Final Completion.
- C. Requirements for Final Acceptance and Payment.

1.2 RELATED REQUIREMENTS

- A. Section 00 70 00 – General Conditions: Substantial Completion, Final Completion, Final Payment, Final Acceptance.
- B. Section 01 11 13 – Summary of Work.
- C. Section 01 29 73 – Schedule of Values.
- D. Section 01 29 76 – Application for Payment.
- E. Section 01 33 00 – Submittal Procedures.
- F. Section 01 73 00 – Execution Requirements
- G. Section 01 78 39 – Project Record Documents.

1.3 SUBSTANTIAL COMPLETION SUBMITTALS

- A. The following items must be submitted to the Authority prior to requesting the Substantial Completion Inspection:
 - 1. All test reports including electrical and mechanical systems.
 - 2. Project Record Documents.
 - 3. Operation and Maintenance Data.
 - 4. Warranties and Bonds.
 - 5. Any required certificates of inspection.
- B. The following items must be available at the project site prior to requesting the Substantial Completion Inspection:
 - 1. Spare Parts and Maintenance Materials.
 - 2. Keys.
- C. No progress payments will be made for Substantial Completion until all required submittals have been submitted and accepted by the Authority.

1.4 SUBSTANTIAL COMPLETION

- A. In accordance with Section 00 70 00 – General Conditions, Article 13.10 Substantial Completion, the Contractor shall notify the Authority in writing that the Work or a

portion of the Work which has been specifically identified in the Contract Documents (except for items specifically listed by the Contractor as incomplete) is substantially complete and request that the Authority issue a Certificate of Substantial Completion, see Section 01 77 00A - Certificate of Substantial Completion. The Authority will consider the Contractor's request for Substantial Completion only when:

1. Written request for Substantial Completion is provided at least ten (10) calendar days in advance of the Substantial Completion inspection date.
 2. Pre-Commissioning Substantial Completion Inspection Checklist is submitted, see Section 01 11 13 – Summary of Work. Note on the checklist any known items needing to be completed or corrected.
 3. All equipment and systems have been tested, adjusted, are properly operating and fully functional.
 4. All automated and manual controls are fully operational and the entire system is ready for commissioning.
- B. When all of the preceding requirements for the consideration of Substantial Completion have been met, the Authority and/or their designee will conduct a scheduled Substantial Completion inspection. If upon the completion of the inspection, the Authority should find that the Work is not substantially complete, the Authority will promptly notify the Contractor in writing, listing observed deficiencies.
- C. The Contractor shall remedy deficiencies and send a second written notice of Substantial Completion.
- D. When the Authority finds the Work is substantially complete, it will issue a certificate of Substantial Completion with an attached punch list of deficiencies, all in accordance with the provisions of the General Conditions.
- E. The Contractor shall be responsible for scheduling the activities required for Substantial Completion to enable completion within the Contract Time.

1.5 FINAL COMPLETION

- A. In accordance with Section 00 70 00 – General Conditions, Article 13.13 Final Completion, when the Contractor considers that it has completed all the deficiencies listed on the Substantial Completion punch list, and that the Work is otherwise complete, it shall submit written certification that:
1. Contract Documents have been reviewed.
 2. Work has been completed in accordance with Contract Documents, and deficiencies listed with certificate of Substantial Completion have been corrected.
 3. Work is complete and ready for final inspection.

- B. Upon the receipt of the preceding written notice, the Authority will conduct a Final Completion inspection. If the Authority should then find the Work to be incomplete, it will promptly notify the Contractor in writing with a list of observed deficiencies.
- C. The Contractor shall remedy deficiencies and transmit to the Authority a second certification of Final Completion.
- D. The Authority reserves the right to review photographic documentation in lieu of on-site inspection.
- E. When the Authority determines the Work is complete, all in accordance with the General Conditions article, "Final Completion and Application for Payment", the Contractor may make application for Final Payment.

1.6 REINSPECTION FEES

- A. In accordance with Section 00 70 00 – General Conditions, Articles 13.10 Substantial Completion and 13.12 Final Inspection, the Contractor shall pay for all costs incurred by the Authority for re-inspection.
- B. The Authority may deduct the re-inspection costs from the application for final payment.

1.7 FINAL ACCEPTANCE AND PAYMENT

- A. Following the issuance of Final Completion, and subject to the completion of requirements specified in Section 00 70 00 – General Conditions, Articles 13.14 Final Payment and 13.15 Final Acceptance, the Authority will review the project files for completeness. The Authority may require the Contractor to submit or re-submit any of the following documents, upon request:
 - 1. Contractor's transmittal letter: O&M Data.
 - 2. Contractor's transmittal letter: Warranty/Bonds.
 - 3. Contractor's transmittal letter: Record Documents.
 - 4. Spare parts, maintenance materials receipts.
 - 5. Contractor's transmittal letter: Keys & keying schedule.
 - 6. Contractor's certification of insurance.
 - 7. EEO compliance certification (Federally funded projects only).
 - 8. Submittals and miscellaneous registers.
 - 9. Original final pay estimate.
 - 10. Contractor's release.
 - 11. Department of Labor Notice of Completion (NOC).
 - 12. Other documentation as required by the Authority.
- B. Statement of Adjustment of Accounts – The Authority may require the Contractor to submit a final statement reflecting adjustments to the Contract Price showing:

1. Original Contract Price.
 2. Previous Change Orders.
 3. Changes under Allowances.
 4. Changes under Unit Prices.
 5. Deductions for uncorrected Work.
 6. Penalties and Bonuses.
 7. Deductions for Liquidated Damages.
 8. Deductions for Re-inspection Fees.
 9. Other adjustments to Contract Price.
 10. Total Contract Price as adjusted.
 11. Previous payments.
 12. Sum remaining due.
- C. The Authority will issue a final Change Order reflecting all remaining adjustments to Contract Price not previously made by Change Orders.
- D. See Section 01 29 73 – Schedule of Values for minimum value that shall be assigned for Final Acceptance.
- E. The Contractor shall cooperate with the Authority and shall provide the requested documentation.
- F. When the Authority determines its files are complete, it will make final payment and issue a letter of Final Acceptance.

PART 2 – PRODUCTS (NOT USED)

PART 3 – EXECUTION (NOT USED)

END OF SECTION



CERTIFICATE OF SUBSTANTIAL COMPLETION

Project: Napaskiak RPSU Project On Site Construction	A/E Project Number: _____
To: _____	Community: _____
_____	Contract Number: _____
From: Alaska Energy Authority	Contract Date: _____

The work performed under this contract has been reviewed and found to be substantially complete. The date of substantial completion of the project or portion thereof designated above is hereby established as _____ which is also the date of commencement of applicable warranties required by the Contract Documents, except as stated below.

Definition of Date of Substantial Completion

The Date of Substantial Completion of the Work or designated portion thereof is the date certified by the Project Manager when construction is sufficiently complete in accordance with the Contract Documents, so the _____ can occupy or utilize the work or designated portion thereof for the use for which it is intended, as expressed in the Contract Documents.

A list of items to be completed or corrected, prepared by the Project Manager is attached hereto. The failure to include any items on such list does not alter the responsibility of the Contractor to complete all work associated with the Contract Documents.

The date of commencement of warranties for items on the attached list will be the date of final payment unless otherwise agreed to in writing.

Attachments:

Alaska Energy Authority: _____	Date: _____
Project Manager	

SECTION 01 78 39
PROJECT RECORD DOCUMENTS

PART 1 – GENERAL

1.1 SECTION INCLUDES

- A. Maintenance of Record Documents.
- B. Submittal of Record Documents.

1.2 RELATED REQUIREMENTS

- A. Section 00 70 00 - General Conditions: Record Documents.
- B. Section 01 11 13 – Summary of Work.
- C. Section 01 29 76 – Application for Payment.
- D. Section 01 33 23 – Shop Drawings, Product Data.
- E. Section 01 77 00 – Contract Closeout Procedures.
- F. Technical Specifications: Manufacturer's certificates and certificates of inspection.

1.3 MAINTENANCE OF RECORD DOCUMENTS

- A. In addition to requirements in General Conditions, maintain at the site for the Authority one accurate and up to date record copy of:
 - 1. Contract Drawings.
 - 2. Specifications.
 - 3. Staking Sheets.
 - 4. Addenda.
 - 5. Change Orders and other modifications to the Contract.
 - 6. Reviewed Shop Drawings and product data.
 - 7. Field test records.
 - 8. Inspection certificates.
 - 9. Manufacturer's certificates.
- B. Prior to Substantial Completion, provide original or legible copies of each item maintained by the Contractor.
- C. Delegate responsibility for management of maintenance of Record Documents to one person on the Contractor's staff as approved in advance by the Authority.
- D. Promptly following award of Contract, secure from the Authority, at no cost to the Contractor, one complete set of all Documents comprising the Contract.
- E. Immediately upon receipt of job set described above, identify each Document with title "RECORD DOCUMENTS – JOB SET".

- F. Store record documents and samples in field office apart from documents used for Construction. Provide files, racks, and secure storage for Record Documents and samples.
- G. Label and file Record Documents and samples in accordance with Section number listings in table of contents of this Project manual. Label each document "PROJECT RECORD" in neat, large, printed letters.
- H. Maintain Record Documents in a clean, dry and legible condition. Do not use record documents for construction purposes.
- I. Use all means necessary to maintain job set of Record Documents completely protected from deterioration and from loss and damage until completion of Work and transfer of recorded data to the Authority.
- J. Do not use job set for any purpose except entry of new data and for review and copying by the Authority.
- K. Keep record documents and samples available for inspection by the Authority.
- L. Upon request by the Authority, and at time of each Application for Payment, enable inspection of Record Documents by the Authority for review as to completeness.
- M. Prior to submitting request for Final Payment, obtain the Authority's approval of final Record Documents.

1.4 RECORDING

- A. Record information on a set of 'black-line' opaque Drawings, and in a copy of a Project manual, provided by the Authority.
- B. Using felt tip marking pens or colored pencil, maintaining separate colors for each major system, clearly describe changes by note and by graphic line, as required. Date all entries. Call attention to entry by a "cloud" around area or areas affected.
- C. Thoroughly coordinate all changes within Record Documents, making adequate and proper entries on each Specification Section and each sheet of Drawings and other Documents where such entry is required to properly show change or selection.
- D. When a change within Record Documents is referenced to another document, such as a RFI's, Shop Drawing or Change Order, attach a copy of the referenced document to the respective Record Drawing or Record Specification where the entry is made.
- E. Contract Drawings and Shop Drawings: Legibly mark each item to record actual construction, including:
 - 1. Measured locations of internal utilities and appurtenances concealed in construction, referenced to visible and accessible features of construction.
 - 2. Field changes of dimension and detail.
 - 3. Changes made by modifications.
 - 4. Details not on original Contract Drawings.
 - 5. References to related Shop Drawings and modifications.

6. Clearly label all changes and show dimensions to establish size and location. All identifications shall be sufficiently descriptive to relate reliably to Specifications.
- F. Other Documents: Maintain manufacturer's certifications, inspection certifications, and field test records required by individual Specifications sections.

1.5 SUBMITTAL OF RECORD DOCUMENTS

- A. Upon submittal of the completed Record Documents, make changes in Record Documents as required by the Authority.
- B. Transmit with cover letter in duplicate, listing:
 1. Date.
 2. The Authority's Project title and number.
 3. Contractor's name, address, and telephone number.
 4. Number and title of each record document.
 5. Signature of the Contractor or authorized representative.
- C. Final Record Documents shall include both hard copies and digitally scanned copies in *.PDF format (high quality grayscale scans, minimum 200 pixels/inch). Scans shall include front and back of drawings/documents where information occurs on both sides.

PART 2 – PRODUCTS (NOT USED)

PART 3 – EXECUTION (NOT USED)

END OF SECTION

SECTION 02 32 00
GEOTECHNICAL INVESTIGATIONS

PART 1 - GENERAL

1.1 RELATED REQUIREMENTS

- A. Section 00 73 13 Supplementary Conditions.
- B. Division 31.

1.2 SOIL REPORTS

- A. Existing Geotechnical Conditions:
 - 1. A geotechnical report was completed for this project in 2022 and is located immediately following this page.
 - 2. A copy of the geotechnical report is included in these bid documents for informational purposes. However, bidder understands that actual field conditions may vary significantly.
 - 3. Site photos are available upon request.
 - 4. Bidders are encouraged to visit the site and acquaint themselves with site conditions before submitting a Bid, and the submission of a Bid shall be prima facie evidence that they have done so.
 - 5. Prior to bidding, bidders may make their own investigations, as approved by the Authority and the community, to satisfy themselves with site and subsurface conditions.

PART 2 - PRODUCTS

Not Used.

PART 3 - EXECUTION

Not Used.

END OF SECTION

April 07, 2022

20448982 (Napaskiak)

Brian Gray, PE

Gray Stassel Engineering
1000 O'Malley Rd, Suite 200B
Anchorage, AK 99515

GEOTECHNICAL BASELINE CONSIDERATIONS AND RECOMMENDATIONS, RURAL POWER SYSTEM UPGRADE (RPSU), NAPASKIAK, ALASKA

Brian:

This submittal summarizes our project understanding, baseline geotechnical assumptions and foundation recommendations for a new modular power plant for the village of Napaskiak. The Alaska Energy Authority (AEA) has contracted Gray Stassel Engineering (GSE) to develop plans and specification for a replacement powerplant in Napaskiak. You have requested our assistance with design for the foundation systems using a modular powerplant structure. We have developed our baseline geotechnical assumptions and foundation recommendations on existing geotechnical data. A site and project specific geotechnical investigation program was not authorized under our current scope of services with you and AEA.

1.0 PROJECT UNDERSTANDING

A new RPSU primary power module with switch gear and other electric power control systems is planned for the community. Prime movers for the new facility are expected to be diesel piston units. The module is expected to be a single story steel frame structure with an approximate footprint of 17 feet by 42 feet. The roof will be slightly larger than the module with planned dimensions of footprint of approximately 24 feet by 44 feet.

The proposed site for the new module is at the former bulk fuel storage site immediately west of the existing power plant. The existing power plant is a single story structure founded on a steel post and pad foundation system that appears to bear directly on the ground surface. There are no reported foundation distresses or differential movements in excess of expected performance tolerances for the existing power plant. The existing power plant will remain operational until the new RPSU system is operational.

Design loads for the entire module are expected to be approximately 180-kips as a total short-term load state. A series of reinforced concrete pad foundations is desired with a building envelope thermal break between the base of the structure and finish grade. Overhead prime power lines, transformers and associated appurtenances for the RPSU facility are anticipated including diesel fuel supply and return pipelines from the nearby existing bulk fuel storage facility. New fuel storage tanks are not planned as part of the replacement power plant.

The proposed site for the new RPSU facility is inside a former bulk fuel storage area provided in the following [GoogleEarth image](#). The former bulk fuel storage site reportedly includes a containment berm and possibly a fuel

resistant liner of undetermined extent and condition. Reportedly, some prior site preparation and fill placement of undetermined extent and quality is present in or near the planned development area.



Napaskiak RPSU Power Plant, Approximate Location

To our knowledge, there are no reliable design or as-built records related to geotechnical or civil engineering for the current or former site uses. Based on the foundation performance of the existing power plant and bulk fuel storage tanks, we have assumed the prior site preparation included removal of some or all of the highly compressible surface organics and possibly placement of unclassified fill for civil design grading.

In 2001 OASIS Environmental (Oasis) conducted an environmental reconnaissance at the power plant bulk fuel storage area as part of a village-wide initial site characterization program. They visually noted some distress to the existing containment berm and liner system. They also collected shallow depth soil samples at three locations at or near the bulk fuel storage area. Analytical results from Oasis indicated petroleum hydrocarbon concentrations while present were not in excess of the then regulatory thresholds and that some biogenic interference may be indicated in the analytical results. Their draft 2001 recommendations for this site indicated no further action was warranted at that time regarding contaminated materials.

2.0 HISTORICAL GEOTECHNICAL DATA REVIEW

We reviewed previous geotechnical investigations conducted in the village for the following projects:

- Original and replacement school, teacher housing, and wastewater lagoon
- Washeteria
- Water and wastewater projects

- Garage and Armory structures
- At-grade and elevated boardwalks

Based on our review of the geotechnical exploration and laboratory data, it is our opinion the developed village area can be considered to have generally similar subsurface conditions. We have assumed the subsurface conditions inferred from the reviewed geotechnical data will be representative of the subsurface conditions at the planned RPSU facility site adjacent to the existing power plant.

3.0 INFERRED SITE AND SUBSURFACE CONDITIONS

The community of Napaskiak is located approximately six miles south of Bethel along the southeast bank of the Kuskokwim River. The site is located in the Yukon-Kuskokwim Lowland physiographic province. The area around the village is relatively flat with elevation changes on the order of ten feet. The Kuskokwim River at Napaskiak is tidally influenced and subject to flooding during periods of high runoff or ice jams during breakup periods.

The geomorphology of the Napaskiak area is generally reworked sediments deposited by the Kuskokwim River. Soils in Napaskiak generally consist of variable thickness of surficial peat and organic silt becoming a lower organic content silt or a mineral silt with depth. Surface organics are often removed as part of the site preparation efforts for at-grade or load bearing conditions to aid in controlling settlements.

Below the silt, a silty fine grained sand or non-cohesive fine sandy silt has been encountered throughout the area. Soils noted in previous projects are consistent with the U.S. Geologic Survey (USGS) maps, which classify Napaskiak as flood-plain alluvium consisting of mud, silt, and sand with isolated areas gravel and larger dimensioned materials. The mineral soils in the area may have wood, peat and other organic material to depths reasonably expected for both shallow and deep foundations. Based on our review of historic geotechnical data near the planned development site and the reported performance of the existing power plant foundations, permafrost conditions are not expected in the area of the proposed improvement.

The reviewed historic geotechnical data indicated generally consistent soil conditions. For this report, silty soil that exhibited no to low plasticity and behaved as a non-cohesive soil is based on soil density descriptors rather than consistency descriptors for in-place soil characteristics. Soil classified as fine-grained material (silt and clay) that exhibited a cohesive behavior uses consistency descriptors for in-place characteristics.

Subsurface conditions at the proposed development area are expected to consist of three major units.

- **Surface Organics and Organic Silt (Pt/OL):** The uppermost organic rich layer may have been removed or subject to some amount of surcharge loads at the planned development site. If present, the surface peat or organic silt layer is expected to be relatively thin, probably less than one foot thick. Soft organic silt may underly the surface peat to about four feet below the ground surface (bgs).
- **Silt (ML):** Non-plastic to low plasticity silt with fine grained sand or fine sandy silt is expected below the organic-rich layer. The depth of the silty material should be expected to vary from about 10 to 20 feet bgs. The silty material should be considered loose and wet to saturated with depth.
- **Silty Sand and Sandy Silt (SM to ML):** Silty fine grained sand and fine sandy silt is expected below the silt material discussed above. The sand and silt contents of the material are expected to vary both vertically and horizontally but can be generally mixed or interbedded and have increasing fine grained sand content with

depth. This material is considered saturated and should be considered loose increasing to medium dense with depth.

Groundwater is expected throughout the planned development area, probably between 5 and 15 feet bgs. The depth to groundwater should also be expected to vary seasonally and possibly in response to the tide, precipitation and storm surge events.

Permafrost is not anticipated at the planned development site. However, seasonal frost is expected to penetrate at least several feet below the ground surface depending on surface vegetation, snow cover and soil moisture content. The soils within the expected seasonal frost zone are considered highly frost susceptible with the potential to develop large seasonal frost heave forces on foundations.

4.0 ENGINEERING CLIMATE CONSIDERATIONS

While permafrost soil conditions were not inferred in the geotechnical data we reviewed near the project site, we have included a summary of geotechnical climate considerations to support site planning. Forecast air temperature trends were developed for the 2060-2069 period based on publicly available data developed by the University of Alaska Fairbanks, Scenarios Network for Alaska & Arctic Planning (SNAP) group. The SNAP group uses five Intergovernmental Panel on Climate Change (IPCC) General Circulation Models (GCM) they consider most applicable for Alaska. SNAP includes several Representative Concentration Pathways (RCP) for their climate forecasts. For our analysis, we used an RCP of 8.5 (watts/m²) to estimate monthly average air temperatures for select forecast periods. The forecast climate model analysis results have variability. SNAP forecast data include an average of the five GCMs and a two standard deviation ($\pm 2\sigma$) spread for the selected forecast period and the historic air temperature trend.

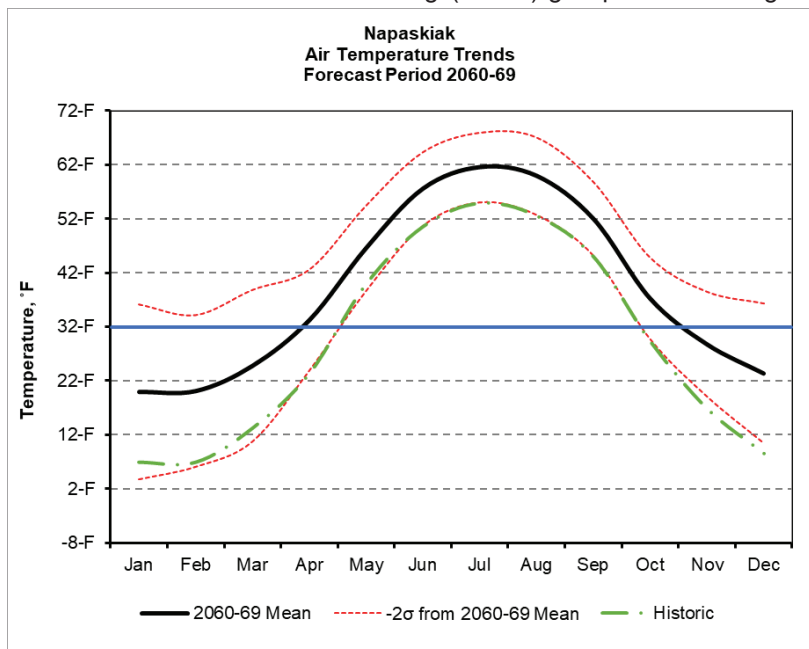

Continued air temperature warming is anticipated for the Napaskiak area through at least the 2060-2069 forecast period used for our analysis. For the 2060-2069 forecast period the mean annual air temperature is forecast to warm with the colder range (two standard deviations below the forecast period mean) roughly similar to historic air temperature trends. Vegetation changes are anticipated in response to the increasing warming trends.

Engineering climate indices suggested for this site based on historic and forecast period averages are summarized below. Also included are suggested engineering climate indices $\pm 2\sigma$ from the mean air temperatures. As noted below, a wide range of engineering climate indices are derived from the forecast period data. Planners and designers are urged to apply these indices appropriately for their intended uses. We can assist planners and designers with applying these suggested indices to their respective needs.

<u>Period</u>		<u>Average Air Temperature</u>	<u>Freeze Index</u>	<u>Thaw Index</u>
Historic	Mean	29.0 F	3,580 F-days	2,600 F-days
2060-69	5 Model Mean	38.8 F	1,290 F-days	3,800 F-days
2060-69	Mean +2 σ	48.7 F	0 F-days	6,120 F-days
2060-69	Mean -2 σ	28.8 F	3,630 F-days	2,520 F-days

5.0 GEOTECHNICAL SEISMIC CONSIDERATIONS

For geotechnical seismic purposes, we have used the 2012 International Building Code (IBC) for this project. Due to our need to rely on existing geotechnical data we have applied seismic soil Site Class “D” for our analysis. Seismic ground motion parameters for this site developed in part on the 2012 IBC are summarized below.

Seismic Parameter

Short Period Spectral Acceleration (S_s)	0.27g
1-second Period Spectral Acceleration (S_1)	0.12g
Site Amplification Coefficient (F_a) for Soil Site Class “D”	1.58
Site Amplification Coefficient (F_v) for Soil Site Class “D”	2.33
Short Period Spectral Response Acceleration (S_{MS})	0.43g
1-second Period Spectral Response Acceleration (S_{M1})	0.27g
Site Modified Peak Ground Acceleration ($PGAM$)	0.18g

Determined for coordinates 60.7058°N, 161.7650°W
 Class I/II/III Risk Category

The non-cohesive soil encountered in the reviewed geotechnical data is considered in a saturated, loose state with increasing soil density with depth. Owing to the loose density of these non-plastic, saturated materials, a soil liquefaction risk may be present at this site depending, in part, on the soil density and fines content (material passing the US Number 200 sieve size).

Based on our review of the site geotechnical data, most of the non-cohesive soils encountered in this area have elevated fines content. As the fines content increases in saturated fine grained sandy soil, the potential for liquefaction tends to decrease. While the site soils may liquefy under seismic loading conditions, we consider the

risk of liquefaction relatively low to marginal due to the expected relatively low peak horizontal ground acceleration (0.18g) and the noted fines content in the shallower depth materials. However, low fines content saturated fine grained sands are also anticipated at this site. These materials, while generally encountered at deeper depths, have an elevated risk of soil liquefaction and seismic induced settlement relative to the increased fines content materials.

If a more refined geotechnical analysis for soil liquefaction risk and potential seismic induced settlement is needed, a site and project specific geotechnical site investigation and engineering analysis will be required. We can provide a recommended program and estimated cost for a more refined soil liquefaction analysis upon your request.

6.0 DISCUSSION

Based on the subsurface conditions expected at the new RPSU facility and our understanding of the site's geologic dispositional environment, we developed recommendations based on the assumptions that the site is an unfrozen area (i.e., no permafrost) with a relatively thin surface organic mat. The shallow depth underlying soils are expected to be predominately loose mineral silts and fine grained sands, both exhibiting non-cohesive soil behavior. Groundwater is expected to be relatively shallow and near surface soils are considered frost susceptible and moisture sensitive.

Due to potential hydrocarbon impacts to the planned development area, an at-grade foundation system for the replacement facilities is desired. An at-grade foundation system may also reduce the risks of damaging any existing liner systems at the site. Reinforced concrete at-grade foundations have been successfully used at other village sites for RPSU modules where unfrozen or thaw stable mineral soils are present. However, some site preparation to verify the removal of near surface compressible soils and to compact the underlying mineral soils was possible at these locations. Site preparation is expected to be limited at the Napaskiak site due, in part, to the risk of damaging the existing fuel resistant liner. Accordingly, we have developed our geotechnical recommendations with a baseline understanding that limited site preparation will be conducted. All parties will need to understand and accept the geotechnical risks of potential increased total and differential settlements for the planned improvements if this approach is adopted.

Seasonal frost is expected throughout the entire planned development area. Historic data indicated seasonal frost depths on the order of 4 to 5 feet bgs were encountered. However, seasonal frost depth can vary widely depending on surface vegetation, albedo, soil moisture contents, local weather conditions and a wide variety of other variables. Seasonal frost related movements acting on at-grade foundations should be anticipated with this approach. While the use of rigid insulation may reduce the impact of seasonal frost related movements, the presence of hydrocarbon contamination in the planned development area can degrade the rigid insulation over time unless additional fuel and product resistant liners are used with the rigid insulation.

For our analysis, we have assumed the site has some unclassified mineral fill, most likely locally obtained fine grained sand and silt. The existing unclassified fill is expected to be relatively thin, probably less than two feet thick. An existing in-place fuel resistant liner is anticipated within or near the base of the unclassified fill material. Beneath the liner, some relict organics are expected to overly mineral silt and fine-grained sands. The mineral soils are expected to be primarily mineral silty sands. The mineral silt and sand materials are expected to extend at least 20 feet below grade and it is reasonable to assume they extend deeper. In general, the unfrozen mineral

silts and fine grained sands are expected to provide adequate load bearing for the planned development provided our site preparation recommendations are followed.

7.0 CONCLUSIONS AND RECOMMENDATIONS

Based on our discussions with the design team, we understand shallow foundations as isolated pads are preferred for the new power plant foundation system. The pads will be either precast or cast-in-place concrete. A nominal four foot high thermal break clear space between the base of the heated structure and finish grade is planned but conductive heat transfer from the building envelop through the foundations should be expected. A slab-on-grade design is not currently envisioned for the facility.

Based on our review of the historic geotechnical data in the general area of the planned RPSU development, the site is considered suitable for the proposed development using at-grade shallow foundations that bear on compacted mineral soil (fill). Our geotechnical recommendations are based, in part, on the foundations not being founded over permafrost soils or subjected to cyclic vibratory or machine loading states. If the building loads or prime movers are expected to impose vibratory or machine loads on the foundations, we must be contacted to review our recommendations presented herein.

7.1 Site Preparation

The existing unclassified fill should be fully thawed, moisture conditioned, scarified several inches deep and proof compacted to a firm, non-yielding state. Caution is advised to not damage the underlying fuel resistant liner during scarifying and proof compaction. Vibratory soil compaction methods are recommended but caution is recommended if the moisture contents of the silts and fine-grained sands are above optimum. The unclassified fill should be considered highly moisture sensitive and can lose significant shear strength if disturbed above its optimal soil moisture range. Regaining the shear strength of the disturbed silt can be challenging at this site if the material's soil moisture content exceeds its optimum moisture content.

During the proof compaction of the existing pad fill, careful attention to the performance of the underlying material is needed. If soft, loose or 'pumping' areas are noted, additional geotechnical measures to strengthen these areas may be warranted, assuming material removal and replacement with granular fill is not feasible. Material strengthening measures may include the use of cellular confinement, material binding agents (polymers, cements, etc.) or reinforced layered geotextiles depending on final fill thickness and grades. We should be present on-site during the proof compaction effort to determine if additional geotechnical reinforcement measures are warranted. Also, in order to reduce construction phase schedule impacts, a reasonable amount of fill reinforcement materials should be included and be on-hand as part of the contractor's mobilization plan.

7.2 Load Bearing Fill

If additional material is planned under load bearing elements over the prepared in-place soil (fill) to meet final grades, a non-woven geotextile similar to Geotex 801 should be placed over the prepared in-place fill prior to any additional fill placement. Ideally, the additional fill under load bearing elements should be well-graded sand and gravel that meets the US Army Corps of Engineers Non-Frost Susceptible (NFS) classification or Possibly Frost Susceptible (PFS). Sand and gravel aggregates meeting S1 or S2 soil frost classification may be suitable for load bearing but should be expected to exhibit increased soil moisture sensitivity and increased seasonal frost related movements. All fill should be moisture conditioned, fully thawed, and placed in nominal 12-inch thick lifts then densified using mechanical compaction methods as recommended for proof compacting.

If locally available mineral soil is being considered for fill under load bearing elements, it may consist of fine grained sands with variable fines (silt) content. Locally obtained material may not meet our above recommendations for NFS or S1 or S2 soil frost classified sand and gravel material. The use of finer grained material for fill can be accepted provided appropriate allowances for increased moisture sensitivity and greater seasonal movements are included with the project design and construction means and methods. Final grades should direct surface water away from the structure.

If locally available finer grained materials are used for fill, measures to control rutting, to reduce the risk of wind or water erosion and to provide an improved trafficking surface during and after construction should be considered. This may include use of granular fill caps, soil cements, or trail hardening systems such as interlocking geoblocks or geocells. We can assist the civil design team with geotechnical considerations for fill or surface protection systems as the project design advances.

If needed, additional pad fill should be placed to meet the civil engineering grades. Additional fill should be fully thawed, moisture conditioned, placed in nominal 8 to 12-inch thick lifts and mechanically compacted to a firm, non-yielding state. We recommend all fill under load bearing elements be densified to at least 95-percent of the material's maximum dry density as determined by the modified Proctor method, ASTM D-1557. In non-load bearing areas, densification to a firm, non-yielding state can be used. As a cost savings measure, it may be acceptable to develop a performance based material compaction acceptance criteria for this project. We should be contacted to review possible performance based fill control acceptance criteria for this project.

7.3 Foundations and Allowable Bearing Pressure

The power plant design concept is expected to use isolated, reinforced concrete square pad foundations bearing on prepared fill. Provided our site preparation and fill material recommendations are followed, an allowable bearing capacity of 1,500 pounds per square foot (psf) is recommended. A one-third increase in this allowable bearing capacity is permitted for short-term, transient load states.

We have assumed the foundation pads will be unheated. For all loading cases, the foundation pads should be nominally 3 to 5 feet square. If isolated foundation pads are less than 9 or greater than 25 square feet, we must be notified to review our recommendations. For geotechnical purposes, we have assumed the isolated concrete foundation pads will be approximately three feet thick. The civil and structural engineer will develop isolated pad dimensions and geometry. The top of the isolated pads should be elevated approximately 8-inches above finish grade or as recommended by the civil and structural engineer. A minimum 8-inch high clear space between the base of the structure and finish grade is recommended to allow for drainage and seasonal frost movement within the fill under the structure. As of this submittal, we understand a nominal 4 foot thick vertical clear space is planned.

7.4 Seasonal Frost Considerations

As noted previously, the in-place soils are considered frost susceptible, possibly highly frost susceptible. Due to the presence of hydrocarbons in the planned development area, measures to aid in controlling seasonal frost related movement such as rigid insulations will require the use of fuel resistant liners, mostly likely above and below the rigid insulation layer. Based on the reported foundation performance of the existing powerplant foundations, seasonal frost related movements do not appear to adversely impact the facility operations. Accordingly, the use of rigid insulation throughout and around the new powerplant foundations and footprint to reduce seasonal frost related movements may be omitted provided measures for periodic releveling of the

structure are provided with the foundation design and the facility operations and maintenance. If periodic releveling is not desired, we must be contacted to review options with the design team for seasonal frost movement control.

7.5 Appurtenances

Appurtenances attached to the building exterior should be designed to permit seasonal frost movements and differential settlement. Flexible connections and allowances for seasonal vertical and horizontal movements that will not result in damage are advised.

7.6 Lateral Resistance

Lateral resistance can be developed as base friction between the concrete foundations and the underlying granular soil (fill). A frictional resistance coefficient of 0.4 can be applied at the concrete foundation/ granular fill contact provided the structure's dead load is used to determine lateral resistance. In addition, passive resistance can be developed along the vertical foundation faces using an equivalent fluid approach. For this case, an active and passive equivalent fluid pressure of $30 \cdot H$ and $200 \cdot H$ pounds per cubic foot (pcf), respectively, can be applied. For each case "H" is the vertical foundation face height in feet, with the uppermost one foot below finish grade ignored for the passive case for a horizontal, level site grade.

7.7 Estimated Settlement

If the site is not underlain with permafrost and/or compressible soils, the site is prepared per our recommendations, and the foundations placed in accordance with the design team's recommendations a total settlement of 2-inches, differential of 1.5-inches is expected. However, greater settlements, both total and differential, may occur. Accordingly, we recommend the foundation design include means and methods for periodic releveling as part of a routine maintenance process. If compressible or permafrost soils are present at the planned development site greater longer-term total and differential settlements should be expected. If machine or cyclic loads are imposed on the foundations, a reduced allowable bearing capacity and/or increased settlements should also be expected. We must be contacted if in-place permafrost soils, compressible soils or cyclic vibratory or machine loads are encountered or are anticipated.

8.0 CONSTRUCTABILITY CONSIDERATIONS

Select construction-phase considerations related to earthwork and foundation elements include:

- Careful observation of surface conditions during site preparation by a member of the design team is recommended
- The site preparation and fill placement under load bearing areas should be observed by an experienced member of the design team
- Seasonal fluctuations in the groundwater elevations should be expected, particularly during periods of prolonged precipitation.
- All finish grades should direct surface water away from the structures
- Roof drainages should consider armored material, geoblocks or similar along their drip lines and channeled roof drainages should direct water away from the foundations
- The contractor will be responsible for all construction-phase site safety

9.0 USE OF REPORT

This report has been prepared for Gray Stassel Engineering, their design team, and the Alaska Energy Authority to support the design of the foundation system for the new RPSU power plant in Napaskiak, Alaska. A key basis of the geotechnical recommendations is the desire to not disturb the existing fuel resistant liner and subsurface (sub liner) soils at this site, primarily related to potential environmental concerns. Accordingly, an elevated risk of foundation total and differential performance is inherent with this approach. The owner and design team will need to understand and accept this geotechnical performance risk. If this risk is unacceptable, we must be notified during the design process in order to discuss options to mitigate this risk with the respective stakeholders.

The final design for the facility is an ongoing effort as of this submittal. If there are significant changes in the nature, design, or location of the facilities, we should be notified so that we may review our conclusions and recommendations in light of the proposed changes and provide a written modification or verification of the changes. We have relied on geotechnical data from other projects as the basis for our analysis and geotechnical recommendations for the replacement power plant. There are risks associated with reliance on historic geotechnical data for engineering analysis and design. If these risks are not acceptable to all parties, a project specific geotechnical exploration program will be required to confirm our baseline geotechnical assumptions summarized with this submittal. We can provide an estimated scope and fee for conducting a site and project specific geotechnical exploration effort at your request.

Also, it is possible to encounter variations in subsurface conditions at the planned development site that differ from the geotechnical data reviewed and used for this submittal. These variations may exist between explorations and also with time. Therefore, inspection and testing by a qualified geotechnical engineer should be included during construction to provide corrective recommendations adapted to the conditions revealed during the work. Regardless, unanticipated geotechnical conditions are commonly encountered and cannot be fully determined through review of historic geotechnical data or through a limited number of explorations or soil samples. Such unexpected conditions frequently result in additional project costs in order to build the project as designed. Therefore, a contingency for unanticipated conditions should be included in the construction budget and schedule. The work program followed the standard of care expected of professionals undertaking similar work in Alaska under similar conditions with reliance on historic geotechnical data. No warranty expressed or implied is made.

10.0 CLOSURE

Please be aware that Golder has been acquired by and is now a Member of the WSP family of companies. Golder remains a legal entity and is the contracting entity for this submittal. We are in the process of integrating the resources of our companies. Correspondence for this proposal should continue to be addressed to the undersigned. We appreciate the opportunity to assist you, the Alaska Energy Authority and the community of Napaskiak, with geotechnical recommendations for the replacement power plant. We are available to address comments or questions to this submittal. Please contact us Richard at 907-830-3171 at your convenience.

Golder Associates USA Inc.

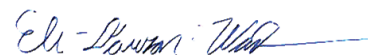

Eli Ward, EIT
Project Engineer



Richard Mitchells, PE
Director

SECTION 02 41 00
DEMOLITION

PART 1 – GENERAL

1.1 SECTION INCLUDES

- A. Selective demolition.

1.2 RELATED REQUIREMENT

- A. Section 02 61 13 - Excavation and Handling of Contaminated Material

1.3 REFERENCE STANDARDS

- A. 29 CFR 1926 - U.S. Occupational Safety and Health Standards; current edition.

PART 2 – PRODUCTS (NOT USED)

PART 3 – EXECUTION

3.1 SCOPE

- A. Remove items intended for demolition as indicated on the Drawings.

3.2 GENERAL PROCEDURES AND PROJECT CONDITIONS

- A. Comply with applicable codes and regulations for demolition operations and safety of adjacent structures and the public.
 - 1. Obtain required permits.
 - 2. Provide, erect, and maintain temporary barriers and security devices.
 - 3. Use physical barriers to prevent access to areas that could be hazardous to workers or the public.
 - 4. Conduct operations to minimize effects on and interference with adjacent structures and occupants.
 - 5. Do not close or obstruct roadways or sidewalks without permit.
 - 6. Conduct operations to minimize obstruction of public and private entrances and exits; do not obstruct required exits at any time; protect persons using entrances and exits from removal operations.
 - 7. Obtain written permission from owners of adjacent properties when demolition equipment will traverse, infringe upon or limit access to their property.
- B. Do not begin removal until receipt of notification to proceed from Owner.
- C. If hazardous materials are discovered during removal operations, stop work and notify the Authority. Hazardous materials include but are not limited to oils not in liquid tight containers, regulated asbestos containing materials, lead, PCB's, and mercury.

3.3 EXISTING UTILITIES

- A. Coordinate work with utility companies; notify before starting work and comply with their requirements; obtain required permits and locates.
- B. Do not disrupt utilities without permit from authority having jurisdiction.
- C. Locate and mark utilities to remain; mark using highly visible tags or flags, with identification of utility type; protect from damage due to subsequent construction, using substantial barricades if necessary.

3.4 DEBRIS AND WASTE REMOVAL

- A. Salvage all surplus equipment in the construction area such as engines or generators, palletized materials, and drums of liquids. Stockpile these items in the area indicated on the Drawings.
- B. Remove all remaining debris and trash from site.
- C. Clean up spillage and wind-blown debris created by demolition work from adjacent public and private lands.
- D. Dispose of all debris and waste in accordance with all local, state, and federal laws.
- E. Leave site in clean condition, ready for subsequent work.

END OF SECTION

SECTION 02 61 13
EXCAVATION AND HANDLING OF CONTAMINATED MATERIAL

PART 1 - GENERAL

1.1 GENERAL REQUIREMENTS

- A. During the engineering field investigation there was no evidence of soil contamination and there is no official record of a spill event at the site; therefore, contaminated soils are not expected to be present. This Section is included to provide guidance in the event that contaminated soil is encountered during performance of the Work.
- B. If the Contractor encounters contaminated soils during performance of the work, immediately stop work in the affected area and notify the Authority for instructions.
- C. Contractor shall not perform any unauthorized excavations. Any contaminated soils exposed as the result of unauthorized excavation shall be stockpiled in accordance with this specification at Contractor's expense.
- D. The discovery of contaminated soils shall not be cause for Contractor delay of work or equipment/worker standby time claims so long as there is other work that can be performed by the Contractor.
- E. This section describes procedures for stockpiling petroleum-contaminated soils.

1.2 RELATED REQUIREMENTS

- A. Section 31 11 00 - Clearing and Grubbing.
- B. Section 31 23 00 - Excavation and Fill.

1.3 REFERENCES

- A. 18 ACC 75 Article 3 Discharge, Reporting, Cleanup, & Disposal of Oil and other Hazardous Substances.
- B. 18 AAC 75 Section 370 Soil Storage.
- C. API 2015 Requirements for Safe Entry and Cleaning of Petroleum Storage Tanks.
- D. 29 CFR 1910.120 Hazardous Waste Operations and Emergency Response.

1.4 DELIVERY, STORAGE, AND HANDLING

- A. All contaminated soil with visible free product encountered during excavation shall be contained and covered in accordance with the long-term stockpile requirement of 18 AAC 75 Section 370.
- B. Stockpile location shall be approved by the Authority and the City.

1.5 ENVIRONMENTAL REQUIREMENTS

- A. All contaminated soil stockpiles must be covered in accordance with 18 AAC 75 Section 370.
- B. Soil liners and covers must withstand 80 mile per hour winds, petroleum emersion, direct sunlight, and -40° F temperatures.

PART 2 - PRODUCTS

2.1 MATERIALS

- A. All liners must meet 18 AAC Section 370 requirements.
- B. Personal Protection Equipment must be appropriate for hazardous encountered on the work site and meet requirements in 29 CFR Subpart I, Sections 1910.132-1910.139.
- C. Equipment to Monitor Hazardous Atmosphere. The contractor shall use oxygen meters, combustible gas indicators, colorimetric indicator tubes, or organic vapor monitors to determine if a toxic, anoxic, or explosive environment exists.

2.2 LINER SEAMING

- A. If field seaming is required, then all seams and joints must be bonded by a qualified technician.

PART 3 - EXECUTION

3.1 EXCAVATION AND HANDLING

- A. Appropriate Personal Protection Equipment will be used to protect workers from work site hazards.
- B. Soil excavated with visible free product shall be contained and covered in accordance with the long term stockpile requirements of 18 AAC 75 Section 370.

END OF SECTION

SECTION 03 30 00
CAST-IN-PLACE CONCRETE

PART 1 - GENERAL

1.1 SUMMARY

- A. This Section specifies cast-in place concrete, including formwork, reinforcement, concrete materials, mixture design, placement procedures, and finishes.

1.2 SUBMITTALS

- A. Product Data: For each type of product indicated.
- B. Design Mixtures: For each concrete mixture.
- C. Shop Drawings: For steel reinforcement.
- D. Material test reports.

1.3 QUALITY ASSURANCE

- A. Manufacturer Qualifications: A firm experienced in manufacturing ready-mixed concrete products and that complies with ASTM C94/C94M requirements for production facilities and equipment.
 - 1. Manufacturer certified according to NRMCA's "Certification of Ready Mixed Concrete Production Facilities."
- B. ACI Publications: Comply with the following unless modified by requirements in the Contract Documents:
 - 1. ACI 301, "Specification for Structural Concrete," Sections 1 through 5.
 - 2. ACI 117, "Specifications for Tolerances for Concrete Construction and Materials."
- C. Pre-installation Conference: Conduct conference at Project site.

PART 2 - PRODUCTS

2.1 FORM-FACING MATERIALS

- A. Smooth-Formed Finished Concrete: Form-facing panels that will provide continuous, true, and smooth concrete surfaces. Furnish in largest practicable sizes to minimize number of joints.
- B. Rough-Formed Finished Concrete: Plywood, lumber, metal, or another approved material. Provide lumber dressed on at least two edges and one side for tight fit.

2.2 REINFORCEMENT

- A. Reinforcing Bars: ASTM A615/A615M, Grade 60, deformed.
- B. Bar Supports: Bolsters, chairs, spacers, and other devices for spacing, supporting, and fastening reinforcing bars and welded wire reinforcement in place. Manufacture bar supports from steel wire, plastic, or precast concrete

according to CRSI's "Manual of Standard Practice."

2.3 CONCRETE MATERIALS

- A. Cementitious Material: Use the following cementitious materials, of the same type, brand, and source, throughout Project:
 - 1. Portland Cement: ASTM C 150, Type I or II.
- B. Aggregates: All aggregates shall be provided from an approved source.
 - 1. Normal-Weight Aggregates: ASTM C 33, graded, 1-inch nominal maximum coarse-aggregate size.
 - 2. Fine Aggregate: ASTM C 33, Free of materials with deleterious reactivity to alkali in cement.
- C. Water: ASTM C 94/C 94M and potable.
- D. Air-Entraining Admixture: ASTM C 260. BASF MB-AE 90 or approved equal.
- E. Chemical Admixtures: Provide admixtures certified by manufacturer to be compatible with other admixtures and that will not contribute water-soluble chloride ions exceeding those permitted in hardened concrete. Do not use calcium chloride or admixtures containing calcium chloride.
 - 1. Water-Reducing Admixture: ASTM C494/C494M, Type A. BASF PS-1466 or approved equal

2.4 CURING MATERIALS

- A. Absorptive Cover: AASHTO M 182, Class 2, burlap cloth made from jute or kenaf, weighing approximately 9 oz./sq. yd. when dry.
- B. Moisture-Retaining Cover: ASTM C 171, polyethylene film or white burlap polyethylene sheet.
- C. Water: Potable.

2.5 CONCRETE MIXTURES

- A. Prepare design mixtures for each type and strength of concrete, proportioned on the basis of laboratory trial mixture or field test data, or both, according to ACI 301.
- B. Proportion normal-weight concrete mixture as follows:
 - 1. Minimum Compressive Strength: 3,500 psi at 28 days.
 - 2. Maximum Water-Cementitious Materials Ratio: 0.45.
 - 3. Slump Limit: 4 inches, plus or minus 1 inch.
 - 4. Air-entrainment is required for all concrete and shall be 6 percent +/- 1-1/2 percent.

2.6 FABRICATING REINFORCEMENT

- A. Fabricate steel reinforcement according to CRSI's "Manual of Standard Practice."

2.7 CONCRETE MIXING

- A. Ready-Mixed Concrete: Measure, batch, mix, and deliver concrete according to ASTM C 94/C 94M.

PART 3 - EXECUTION

3.1 FORMWORK

- A. Design, erect, shore, brace, and maintain formwork according to ACI 301 to support vertical, lateral, static, and dynamic loads, and construction loads that might be applied, until structure can support such loads.
- B. Construct formwork so concrete members and structures are of size, shape, alignment, elevation, and position indicated, within tolerance limits of ACI 117.
- C. Chamfer exterior corners and edges of permanently exposed concrete.

3.2 EMBEDDED ITEMS

- A. Place and secure anchorage devices and other embedded items required for adjoining work that is attached to or supported by cast-in-place concrete. Use setting drawings, templates, diagrams, instructions, and directions furnished with items to be embedded.
- B. General: Comply with CRSI's "Manual of Standard Practice" for placing reinforcement.

3.3 CONCRETE PLACEMENT

- A. Before placing concrete, verify that installation of formwork, reinforcement, and embedded items is complete and that required inspections have been performed.
- B. Deposit concrete continuously in one layer or in horizontal layers of such thickness that no new concrete will be placed on concrete that has hardened enough to cause seams or planes of weakness. If a section cannot be placed continuously, provide construction joints as indicated. Deposit concrete to avoid segregation. Consolidate placed concrete with mechanical vibrating equipment according to ACI 301.
- C. Cold-Weather Placement: Comply with ACI 306.1.
- D. Hot-Weather Placement: Comply with ACI 301.

3.4 CONCRETE FINISHING

- A. General: Comply with ACI 302.1R recommendations for screening, re-straightening, and finishing operations for concrete surfaces. Do not wet concrete surfaces.
- B. Float Finish: Consolidate surface with power-driven floats or by hand floating if area is small or inaccessible to power driven floats. Re-straighten, cut down high spots, and fill low spots. Repeat float passes and re-straightening until

surface is left with a uniform, smooth, granular texture.

- C. Rough-Formed Finish: As-cast concrete texture imparted by form-facing material with tie holes and defects repaired and patched. Remove fins and other projections that exceed specified limits on formed-surface irregularities.
- D. Exposed Formed Concrete Vertical Surfaces: Smooth rubbed finish.
- E. Concrete Top Surfaces: Broom finish.

3.5 CONCRETE PROTECTING AND CURING

- A. General: Protect freshly placed concrete from premature drying and excessive cold or hot temperatures. Comply with ACI 306.1 for cold-weather protection and ACI 301 for hot-weather protection during curing.
- B. Cure concrete according to ACI 308.1, by one or a combination of the following methods:
 - 1. Moisture Curing: Keep surfaces continuously moist for not less than seven days.
 - 2. Moisture-Retaining-Cover Curing: Cover concrete surfaces with moisture-retaining cover for curing concrete, placed in widest practicable width, with sides and ends lapped at least 12 inches, and sealed by waterproof tape or adhesive. Cure for not less than seven days. Immediately repair any holes or tears during curing period using cover material and waterproof tape.

3.6 CONCRETE SURFACE REPAIRS

- A. Defective Concrete: Repair and patch defective areas when approved by Engineer. Remove and replace concrete that cannot be repaired and patched to Engineer's approval.

3.7 FIELD QUALITY CONTROL

- A. Testing and Inspecting: Contractor will engage a qualified independent testing and inspecting agency to perform field tests and inspections and prepare test reports.
- B. Tests shall be performed according to ACI 301 and the Design Drawings.

END OF SECTION

SECTION 06 10 00
ROUGH CARPENTRY

PART 1 – GENERAL

1.1 SUMMARY

- A. This Section includes the following:
 - 1. Framing with dimension lumber.
 - 2. Wood furring, grounds, nailers, and blocking.
 - 3. Sheathing.
 - 4. Roof Underlayment.
 - 5. Fasteners and metal framing anchors.

1.2 RELATED REQUIREMENTS

- A. Section 05 12 10 – Structural Steel Framing and Fabrications
- B. Section 06 17 53 - Shop Fabricated Trusses
- C. Section 07 21 00 - Thermal Insulation

1.3 REFERENCES

- A. American Forest and Paper Association (AFPA) Manual for Wood Frame Construction
- B. Engineered Wood Association
Form E30 Engineered Wood Design/Construction Guide
- C. American Society of Mechanical Engineers (ASME)
 - B18.2.1 Square and Hex Bolts and Screws (Inch Series)
 - B18.6.1 Wood Screws (Inch Series)
- D. American Society for Testing and Materials (ASTM)
 - A153 Specification for Zinc-Coating (Hot-Dip of Iron and Steel Hardware)
 - A307 Specification for Carbon Steel Bolts and Studs, 60,000 PSI Tensile Strength
 - A563 Specification for Carbon and Alloy Steel Nuts
 - A653 Specification for Steel Sheet, Zinc-Coated (Galvanized) or Zinc-Iron Alloy-Coated (Galvannealed) by the Hot-Dip Process
 - D245 Practice for Establishing Structural Grades and Related Allowable Properties for Visually Graded Lumber
 - D2555 Test Method for Establishing Clear Wood Strength Values
- E. American Wood Preservers Association (AWPA)

- C2 Lumber, Pressure Treatment
- M4 Standard for the Care of Preservative-Treated Wood Products
- F. Federal Specification (FS)
 - FF-N-105B Nails, Brads, Staples and Spikes: Wire, Cut and Wrought
- G. International Conference of Building Officials (ICBO)
 - International Building Code (IBC) Chapter 23 Wood
- H. U.S. Department of Commerce, National Institute of Standards and Technology
 - PS 1 US Product Standard for Construction and Industrial Plywood
 - PS 2 Performance Standard for Wood-Based Structural-Use Panels
 - PS 20 American Softwood Lumber Standard (ASLS)

1.4 SUBMITTALS

- A. Product Data: Submit manufacturer's product data for each distinct product specified.
- B. Wood treatment data as follows, including chemical treatment manufacturer's warranty and instructions for handling, storing, installing, and finishing treated materials:
 - 1. For each type of preservative-treated wood product, include certification by treating plant stating type of preservative solution and pressure process used, net amount of preservative retained, and compliance with applicable standards.
 - 2. For waterborne-treated products, include statement that moisture content of treated materials was reduced to levels indicated before shipment to Project site.

1.5 DELIVERY, STORAGE, AND HANDLING

- A. Deliver wood products bundled or crated to provide adequate protection during transit and job storage, with required grade marks clearly identifiable. Inspect wood products for damage upon delivery. Remove and replace damaged materials.
- B. Keep materials under cover and dry. Protect from weather and contact with damp or wet surfaces. Stack lumber, plywood, and other panels. Provide for air circulation within and around stacks, and under temporary coverings.
- C. For lumber and plywood pressure treated with waterborne chemicals, place spacers between each bundle to provide air circulation.
- D. Protect sheet materials during handling to prevent breaking of corners and damage to surfaces.

PART 2 – PRODUCTS

2.1 LUMBER, GENERAL

- A. Lumber Standards: Comply with PS 20-99, “American Softwood Lumber Standard,” and with applicable grading rules of inspection agencies certified by ALSC’s Board of Review. Lumber design values are to comply with ASTM D245 and ASTM D2555.
- B. Inspection Agencies: Inspection agencies, and their grading rules include the following:
 - 1. West Coast Lumber Inspection Bureau (WCLIB)
No. 17 Standard Grading Rules for West Coast Lumber
 - 2. Western Wood Products Association (WWPA)
Western Lumber Grading Rules
- C. Grade Stamps: Provide lumber with each piece factory marked with grade stamp of inspection agency evidencing compliance with grading rule requirements and identifying grading agency, grade, species, moisture content at time of surfacing, and mill.

For exposed lumber, furnish pieces with grade stamps applied to ends or back of each piece, or omit grade stamps and provide grade-compliance certificates issued by inspection agency.
- D. Where nominal sizes are indicated, provide actual sizes required by PS 20-99 for moisture content specified. Where actual sizes are indicated, they are minimum dressed sizes for dry lumber.
 - 1. Provide dressed lumber, surfaced four sides (S4S), unless otherwise indicated.
 - 2. Provide dry lumber with 19 percent maximum moisture content at time of dressing for 2-inch nominal (38 mm actual) thickness or less, unless otherwise indicated.

2.2 WOOD-PRESERVATIVE-TREATED MATERIALS

- A. General: Where lumber or plywood is indicated as preservative treated or is specified to be treated, comply with applicable requirements of AWWA C2 (lumber) and AWWA C9 (plywood). Mark each treated item with Quality Mark Requirements of inspection agency approved by ALSC’s Board of Review.
- B. For exposed items indicated to receive stained finish, use chemical formulations that do not bleed through, contain colorants, or otherwise adversely affect finishes.
- C. Pressure treat aboveground items with waterborne preservatives to minimum retention of 0.25 lb./cu. ft. (4.0 kg/cu. m.). After treatment, kiln-dry lumber and plywood to maximum moisture content of 19 and 15 percent, respectively. Treat indicated items and the following:

1. Wood indicated on Drawings as treated.
 2. Wood sills, sleepers, blocking, furring, stripping, and similar concealed members in contact with masonry or concrete.
 3. Wood framing members less than 18 inches (460 mm) above grade.
 4. Wood floor plates installed over concrete slabs, steel floors, or directly in contact with earth.
- D. Pressure treat wood members in contact with ground or freshwater with waterborne preservatives to minimum retention of 0.60 lb./cu. ft.
- E. Complete fabrication of treated items before treatment, where possible. If cut after treatment, apply field treatment complying with AWPAC M4 to cut surfaces. Inspect each piece of lumber or plywood after drying and discard damaged or defective pieces.

2.3 DIMENSION LUMBER

- A. All lumber to equal No. 2 or better Douglas Fir or Hem Fir.

2.4 MISCELLANEOUS LUMBER

- A. General: Provide lumber for support or attachment of other construction, including rooftop equipment curbs and support bases, cant strips, bucks, nailers, blocking, furring, grounds, stripping, and similar members.
- B. Fabricate miscellaneous lumber from dimension lumber of sizes indicated, and into shapes shown on Contract documents.
- C. Moisture Content: 19 percent maximum for lumber items not specified to receive wood preservative treatment.
- D. Grade and Species: For dimension lumber sizes, provide No. 2, or better Douglas Fir.

2.5 SHEATHING

- A. Exterior rated Type PS-1 structural plywood of the thickness indicated.

2.6 ROOF UNDERLAYMENT

- A. Self-Adhering, High-Temperature Sheet: Minimum 30 to 40 mils thick. Grace Ice and Water Shield, or approved equal.

2.7 FASTENERS

- A. General: Provide fasteners of size and type indicated that comply with requirements specified.
- B. Where rough carpentry work is exposed to weather, in ground contact, or in areas of high relative humidity, provide fasteners with hot-dip, zinc-coating per ASTM A153
- C. Nails, Wire, Brads, and Staples: ASTM F1667
- D. Wood Screws: ASME B18.6.1.

- E. Lag Bolts: ASME B18.2.1.
- F. Bolts: Steel bolts complying with ASTM A307, Grade A with ASTM A563 hex nuts and, where indicated, flat washers.

2.8 METAL FRAMING ANCHORS

- A. General: Provide galvanized steel framing anchors of structural capacity, type, and size indicated, with allowable design loads as published by manufacturer, that meet or exceed those indicated.
- B. Galvanized Steel Sheet: Hot-dip, zinc-coated steel sheet complying with ASTM A653, G60 coating designation; structural, commercial, or lock-forming quality, as standard with manufacturer for type of anchor indicated.

PART 3 – EXECUTION

3.1 INSTALLATION, GENERAL

- A. Discard units of material with defects that impair quality of rough carpentry and that are too small to use with minimum number of joints or optimum joint arrangement.
- B. Set rough carpentry to required levels and lines, with members plumb, true to line, cut, and fitted.
- C. Fit rough carpentry to other construction; scribe and cope as required for accurate fit. Correlate location of furring, nailers, blocking, grounds, and similar supports to allow attachment of other construction.
- D. Apply field treatment complying with AWWA M4 to cut surfaces of preservative-treated lumber and plywood.
- E. Securely attach rough carpentry work to substrate by anchoring and fastening as indicated, complying with IBC Table 2304.9.1 Fastening Schedule.

3.2 WOOD GROUNDS, NAILERS, BLOCKING, AND SLEEPERS

- A. Install wood grounds, nailers, blocking, and sleepers where shown, and where required for attaching other work. Form to shapes shown and cut as required for true line and level of attached work. Coordinate locations with other work involved.

3.3 WOOD FURRING

- A. Install plumb and level with closure strips at edges and openings. Shim with wood as required for tolerance of finish work.
- B. Firestop furred spaces of walls at each floor level, and at ceiling with wood blocking or noncombustible materials, accurately fitted to close furred spaces.

3.4 WOOD FRAMING, GENERAL

- A. Framing Standard: Comply with AFPA's "Manual for Wood Frame Construction," unless otherwise indicated.
- B. Install framing members of size and at spacing indicated.
- C. Do not splice structural members between supports.

- D. Firestop concealed spaces of wood-framed walls and partitions at each floor level and at ceiling line of top story. Where firestopping is not inherent in framing system used, provide closely fitted wood blocks of 2-inch nominal (38 mm actual) thickness lumber of same width as framing members.
- E. Arrange studs so that wide face of stud is perpendicular to direction of wall or partition and narrow face is parallel.
- F. Provide single bottom plate and double top plates using members of 2-inch nominal (38 mm actual) thickness whose widths equal that of studs; except single top plate may be used for non-load-bearing partitions. Nail or anchor plates to supporting construction, unless otherwise indicated.
- G. Construct corners and intersections with three (3) or more studs. Provide miscellaneous blocking and framing as shown, and as required to support facing materials, fixtures, specialty items, and trim.
- H. Frame openings with multiple studs and headers. Provide nailed header members of thickness equal to width of studs. Set headers on edge and support on jamb studs. For load-bearing walls, provide double-jamb studs for openings 72 inches (1.8 m) and less in width, and triple-jamb studs for wider openings. Provide headers of depth shown as indicated on Drawings.

END OF SECTION

SECTION 06 17 53
SHOP-FABRICATED WOOD TRUSSES

PART 1 – GENERAL

1.1 SUMMARY

- A. This Section includes wood roof trusses.

1.2 RELATED REQUIREMENTS

- A. Section 05 12 10 – Structural Steel Framing and Fabrications
- B. Section 06 10 00 - Rough Carpentry

1.3 SUBMITTALS

- A. Product Data: Metal plate connectors, metal-truss accessories, and fasteners.
- B. Shop Drawings: Show fabrication and installation details for trusses.
 - 1. Show location, pitch, span, camber, configuration, and spacing for each type of truss required.
 - 2. Indicate sizes, stress grades, and species of lumber.
 - 3. Indicate locations, sizes, and materials for permanent bracing required to prevent buckling of individual truss members due to design loads.
 - 4. Indicate type, size, material, finish, design values, orientation, and location of metal connector plates.
 - 5. Show splice details and bearing details.
 - 6. Indicate compliance with performance requirements and design criteria as indicated on the Drawings.
 - 7. Including analysis data signed and sealed by an engineer licensed to practice in the State of Alaska.

1.4 QUALITY ASSURANCE

- A. Metal Connector-Plate Manufacturer Qualifications: A manufacturer that is a member of TPI and that complies with quality-control procedures in TPI 1 for manufacture of connector plates.
 - 1. Manufacturer's responsibilities include providing professional engineering services needed to assume engineering responsibility.
 - 2. Engineering Responsibility: Preparation of Shop Drawings and comprehensive engineering analysis by a qualified professional engineer.
- B. Fabricator Qualifications: Shop that participates in a recognized quality-assurance program, complies with quality-control procedures in PTI 1, and involves third-party inspection by an independent testing and inspecting agency acceptable to

Architect and authorities having jurisdiction.

- C. Engineering Qualifications: Shop drawings to be signed and sealed by an engineer licensed to practice in the State of Alaska.

1.5 DELIVERY, STORAGE, AND HANDLING

- A. Handle and store trusses to comply with recommendations in SBCA BCSI, “Building Component Safety Information: Guide to Good Practice for Handling, Installing, Restraining, & Bracing Metal Plate Connected Wood Trusses”.

PART 2 – PRODUCTS

2.1 PERFORMANCE REQUIREMENTS

- A. Trusses shall be designed for the gravity loads, wind and seismic lateral and uplift loads, and support conditions as indicated on the Drawings and Specifications. No duration of load increase in stresses will be allowed for snow loading. Unbalanced snow and drift loading is required.
- B. Wood truss design criteria shall be in accordance with the 2012 International Building Code and ASCE/SEI 7-10 “Minimum Design Loads for Buildings and Other Structures”. Design shall use the parameters listed on the Drawings.
 - 1. Trusses shall be designed, or supplemented, for anticipated shipping and handling loads.
- C. Comply with applicable requirements and recommendations of TPI 1, TPI DSB, and SBCA BCSI.
- D. Wood Structural Design Standard: Comply with applicable requirements in AF&PA’s “National Design Specifications for Wood Construction” and it’s “Supplement”.

2.2 GENERAL REQUIREMENTS

- A. Dimension Lumber: DOC PS 20 and applicable rules of grading agencies indicated. If no grading agency is indicated, provide lumber that complies with the applicable rules of any rules-writing agency certified by the ALSC Board of Review. Provide lumber graded by an agency certified by the ALSC Board of Review to inspect and grade lumber under the rules indicated.
 - 1. Factory mark each piece of lumber with grade stamp of grading agency.
 - 2. Provide dressed lumber, S4S, unless otherwise indicated.
 - 3. Species: Hem or Douglas Fir, unless otherwise indicated.
 - 4. Grade No. 2 or better.

2.3 METAL CONNECTOR PLATES

- A. General: Fabricate connector plates to comply with TPI 1.
- B. Hot-Dip Galvanized-Steel Sheet: ASTM A 653/A 653M; Structural Steel (SS),

high-strength low-alloy steel Type A (HSLAS Type A), or high-strength low-alloy steel Type B (HSLAS Type B), G60 coating designation; and not less than 0.036 inches thick.

2.4 FASTENERS

- A. General: Provide fasteners of size and type indicated that comply with requirements specified in this article for material and manufacture.
 - 1. Provide fasteners for use with metal framing anchors that comply with written recommendations of metal framing manufacturer.
 - 2. Where trusses are exposed to weather, in ground contact, or in an area of high relative humidity, provide fasteners with hot-dip zinc coating complying with ASTM A 153/A 153 M.
- B. Nails, Brads, and Staples: ASTM F 1667.

2.5 METAL FRAMING ANCHORS AND ACCESSORIES

- A. Allowable design loads, as published by manufacturer, shall comply with or exceed those of basis-of-design products. Manufacturer's published values shall be determined from empirical data or by rational engineering analysis and demonstrated by comprehensive testing performed by a qualified independent testing agency. Framing anchors shall be punched for fasteners adequate to withstand the same loads as the anchors.
- B. Galvanized-Steel Sheet: Hot-dip, zinc-coated steel sheet complying with ASTM A 653/A 653M, G60 coating designation.

2.6 FABRICATION

- A. Assemble truss members in design configuration indicated; use jigs or other means to ensure uniformity and accuracy of assembly, with joints closely fitted to comply with tolerances in TPI 1. Position members to produce design camber indicated.
 - 1. Fabricate wood trusses within manufacturing tolerances in TPI 1.
- B. Connect truss members by metal connector plates located and securely embedded simultaneously in both sides of wood members by air or by hydraulic press.

PART 3 – EXECUTION

3.1 INSTALLATION – GENERAL

- A. Install wood trusses only after supporting construction is in place and is braced and secured.
- B. If trusses are delivered to Project site in more than one piece, assemble trusses before installing.
- C. Hoist trusses in place by lifting equipment suited to sizes and types of trusses required, exercising care not to damage truss members or joints by out-of-plane bending or other causes.

- D. Install and brace trusses according to TPI 1 recommendation and as indicated.
- E. Anchor trusses securely at bearing points; use metal truss tie-downs or floor truss hangers as applicable. Install fasteners through each fastener hole in metal framing anchors according to manufacturer's fastening schedules and written instructions.
- F. Securely connect each truss ply required for forming built-up girder trusses.
- G. Install and fasten permanent bracing during truss erection and before construction loads are applied. Anchor ends of permanent bracing where terminating at walls or beams.
- H. Install wood trusses within installation tolerances in TPI 1.
- I. Do not alter trusses in field. Do not cut, drill, notch, or remove truss members.
- J. Replace wood trusses that are damaged or do not comply with requirements.

END OF SECTION

SECTION 07 21 00
THERMAL INSULATION

PART 1 – GENERAL

1.1 SECTION INCLUDES

- A. Polystyrene foam-plastic board.
- B. Fiberglass batt or blanket.

1.2 RELATED REQUIREMENTS

- A. Section 03 30 00 - Cast-In-Place Concrete
- B. Section 05 12 10 - Structural Steel Framing and Fabrications
- C. Section 06 10 00 - Rough Carpentry
- D. Section 31 23 00 - Excavation and Fill
- E. Section 31 23 33 - Trenching and Backfill For Utilities.
- F. Section 33 61 14 - PEX Arctic Pipe
- G. Section 33 61 24 - Steel Arctic Pipe

1.3 SUBMITTALS

- A. Product Data: For each type of product.

1.4 DELIVERY, STORAGE, AND HANDLING

- A. Protect insulation materials from physical damage and from deterioration due to moisture, soiling, and other sources. Store inside and in a dry location. Comply with manufacturer's written instructions for handling, storing, and protecting during installation.
- B. Do not expose foam-plastic board to sunlight except to necessary extent for period of installation and concealment.

PART 2 – PRODUCTS

2.1 POLYSTYRENE FOAM-PLASTIC BOARD

- A. Insulation Board: Extruded polystyrene rigid insulation. Maximum water absorption shall not exceed 0.3% by volume, as determined in ASTM C272. Thermal resistance (R-value) shall not be less than 4.5 per inch at 75°F as determined by ASTM C177. The minimum board size shall be 2-inches by 2-feet by 8-feet. Compressive strength at yield or 10% deformation shall not be less than 40 PSI. Dow Styrofoam Hi-40 or approved equal.

2.2 FIBERGLASS BATT

- A. Blanket/Batt Insulation: Roll or batt type blanket insulation, fiberglass or mineral wool. Minimum R value 13 for 3-1/2" thickness and 19 for 6-1/2" thickness.

PART 3 – EXECUTION

3.1 INSTALLATION OF INSULATION BOARD

- A. Prior to placing the insulation board, blade, shape, and compact subgrade to a flat, smooth, firm, and unyielding surface. Visually inspect embankment surface and remove bumps, ruts, deleterious material, debris, and any other objects that may prevent proper installation, attachment, and performance of the insulation board.
- B. Place a sand bedding leveling course at least two (2) inches thick on the subgrade.
- C. Set each board accurately to the line and grade established and anchor firmly in place.
- D. Do not compact fill over insulation until it is completely thawed through its entire thickness.
- E. Use caution and appropriate construction techniques to ensure the insulation is protected and not damaged during formation of embankments.
- F. Remove and replace, at no cost to the Authority, any insulation that has been damaged or displaced.

3.2 INSTALLATION OF FIBERGLASS BATT

- A. Completely fill spaces to create a complete and unbroken thermal envelope around the building interior.
- B. Prior to covering, ensure that all insulation is secure so that it will not settle and create voids.
- C. Install a minimum 6 mil polyethylene sheet vapor barrier over all interior surfaces. Tape all seams and joints.

END OF SECTION

SECTION 07 41 13
FORMED METAL ROOF PANELS

PART 1 – GENERAL

1.1 SECTION INCLUDES

- A. Metal roof panels.
- B. Flashing and trim integral to roof panels.
- C. Clips, anchoring devices, fasteners, and accessories for installation of panel system.
- D. Snow fence system.

1.2 SUBMITTALS

- A. Product Data: Metal panels, fasteners, sealants, accessories, and snow fence components.
- B. Shop Drawings:
 - 1. Calculations demonstrating compliance with performance requirements and design criteria as indicated on the Drawings.
 - 2. Panel layout and lengths.
 - 3. Fastening requirements by zone
 - 4. Trim, flashing, sealant, and other details of installation.
- C. Manufacturer's installation instructions.

1.3 REFERENCE STANDARDS

- A. UL 580 - Uplift Resistance of Roof Assemblies.
- B. UL 1897 - Uplift Test for Roof Covering Systems.
- C. ASTM A 653 - Standard Specification for Steel Sheet, Zinc-Coated (Galvanized) or Zinc-iron Alloy Coated (Galvannealed) by the Hot-Dip Process.
- D. ASTM A 792 - Standard Specification for Steel Sheet, Aluminum-Zinc Alloy Coated Steel by the Hot-Dip Process.
- E. ASTM A 924 - General Requirements for Steel Sheet, Metallic-Coated by the Hot-Dip Process.

1.4 PERFORMANCE REQUIREMENTS

- A. Structural and Wind Load Tests:
 - 1. Design load/deflection criteria verified from tests per ASTM E 72 "Chamber Method" using a 20 psf (0.96 kPa) simulated wind load with a deflection limit of L/240.
 - 2. FM Approval Standard 4471: Meets windstorm Class 1A [90] and hailstorm Class 1-SH classifications.

3. Underwriters Laboratory (UL) Uplift Tests for Roof Assemblies: UL Class 90 rated in accordance with UL 580 and shall withstand static uplift load of 140 psf when tested on 7 foot purlin spacing and 166 psf when tested on 5-foot purlin spacing.

1.5 QUALITY ASSURANCE

- A. Installer Qualifications: Company specializing in installation of the products specified for projects of similar size and scope with minimum five years documented experience.

1.6 DELIVERY, STORAGE, AND HANDLING

- A. Store products in accordance with Manufacturer's written instructions. Store under cover in manufacturer's unopened packaging with labels intact until ready for installation.
- B. Store products off the ground, with panels sloped for drainage and covered to protect factory finishes from damage.
- C. Do not overload roof structure with stored materials. Do not permit material storage or traffic on completed roof surfaces.

1.7 WARRANTY

- A. Manufacturer's Warranty: Manufacturer's two year limited warranty that panels are free from defects in materials and workmanship, beginning from the date of shipment of panels, but excluding coil coatings (paint finishes) covered under a separate warranty. Warranty does not include interior painted surface of panels.
- B. Submit exterior paint manufacturer's written twenty year limited warranty on paint finish for adhesion to the substrate and a thirty year limited warranty on chalk and color fade.

PART 2 – PRODUCTS

2.1 MANUFACTURERS

- A. Acceptable Manufacturer: AEP Span or approved equal.

2.2 MECHANICALLY SEAMED STANDING SEAM METAL ROOF PANELS

- A. AEP Span, Span Lok HP or approved equal.
 1. Prefinished Galvalume® or Zinalume® sheet, ASTM AZ50 made of 55% aluminum, 1.6% silicon and the balance zinc as described in ASTM specification A792.
 2. Fabricated panel with integral seams continuously locked or crimped together by mechanical means during installation..
 3. Seam Height: 2” high ribs @ 16” centers.
 4. Provide pre-installed sealant within the confines of panel’s female leg designed to seal against adjacent male panel leg.

5. Minimum Thickness: 24 gauge (0.0250 inch) or as indicated on Drawings.
- B. Panel Finish: One coat 70 percent polyvinylidene fluoride, nominal 0.7 mil (0.02 mm) thick, over 0.2 mil (0.005 mm) primer. Color as indicated on Drawings.
- C. Flashing and Trim: Brake-formed sheet metal in the same thickness and finish to match the panels.
- D. Fasteners: Clips, anchoring devices, fasteners, and accessories for installation of panel system as recommended by panel manufacturer for the system specified.
- E. Sealant: Sealant as recommended by panel manufacturer.

2.3 SNOW FENCE

- A. Provide snow fence system as shown on the Drawings. The snow fence shall be a complete system that is compatible with the roof panels and is engineered for the application.
- B. The number of rows indicated on the Drawings is the minimum quantity. If the calculations indicate more, provide additional rows as required. If the calculations indicate less, provide the minimum quantity shown on the Drawings. Install first row 12" above the eave and second row 12" above the bearing wall.

PART 3 – EXECUTION

3.1 EXAMINATION

- A. Examine structural members before beginning installation to ensure that all supporting members are straight, level, plumb and satisfactory for panel installation.
- B. Panel Support Tolerances:
 1. Overall rake to rake tolerances plus or minus 2 inches or plus or minus 1 inch at each rake.
 2. Overall eave to ridge tolerance plus or minus 1 inch or plus or minus 1/2 inch at the eave, end lap and ridge.
 3. Vertical deviation from the nominal roof plane of plus or minus 1/8 inch in any 5 foot length, plus or minus 1/4 inch in any 20 foot length and plus or minus 1/2 inch over the entire roof area.
- C. Verify roof openings, curbs, pipes, sleeves, ducts, or vents through roof are solidly set, reglets are in place, and nailing strips located.
- D. Correct defective conditions before beginning work.
- E. If substrate is the responsibility of another installer, notify Engineer of unsatisfactory preparation before proceeding.

3.2 UNDERLAYMENT INSTALLATION

- A. Provide continuous underlayment in accordance with the Drawings and Specifications. Comply with temperature restrictions of underlayment manufacturer

for installation. Apply wrinkle free, in shingle fashion to shed water, and with end laps of not less than 6 inches staggered 24 inches between courses. Overlap side edges not less than 3-1/2 inches. Roll laps with roller. Cover underlayment within 14 days.

3.3 INSTALLATION GENERAL

- A. Install in accordance with manufacturer's instructions and recommendations including approved shop drawings, installation guidebook, and manufacturer's handbook of construction details.
- B. Anchor securely in place using clips and fasteners spaced in accordance with manufacturer's recommendations and calculations for design wind load criteria.
- C. Install flashing and trim true and in proper alignment.
- D. Protective film on trim shall be removed before exposure to sunlight.
- E. Install sealants where indicated to clean dry surfaces only without skips or voids, to ensure weather tight

3.4 CLEANING

- A. Replace damaged panels and other components of work, which cannot be repaired by finish touch-up or similar minor repair.
- B. Wipe finished surfaces clean of any filings caused by drilling or cutting to prevent rust staining.

3.5 PROTECTION

- A. Protect installed products until completion of project.
- B. Touch-up, repair, or replace damaged products before Substantial Completion.

END OF SECTION

SECTION 07 42 13
FORMED METAL WALL PANELS

PART 1 – GENERAL

1.1 SECTION INCLUDES

- A. Metal wall panels.
- B. Flashing and trim integral to wall panels.
- C. Fasteners and accessories for installation of panel system.

1.2 SUBMITTALS

- A. Product Data: Metal panels, fasteners, sealants, and accessories.
- B. Shop Drawings:
 - 1. Calculations demonstrating compliance with performance requirements and design criteria as indicated on the Drawings.
 - 2. Panel layout and lengths.
 - 3. Fastening requirements by zone
 - 4. Trim, flashing, sealant, and other details of installation.
- C. Manufacturer's installation instructions.

1.3 REFERENCE STANDARDS

- A. UL 580 - Uplift Resistance of Roof Assemblies.
- B. UL 1897 - Uplift Test for Roof Covering Systems.
- C. ASTM A 653 - Standard Specification for Steel Sheet, Zinc-Coated (Galvanized) or Zinc-iron Alloy Coated (Galvannealed) by the Hot-Dip Process.
- D. ASTM A 792 - Standard Specification for Steel Sheet, Aluminum-Zinc Alloy Coated Steel by the Hot-Dip Process.
- E. ASTM A 924 - General Requirements for Steel Sheet, Metallic-Coated by the Hot-Dip Process.

1.4 PERFORMANCE REQUIREMENTS

- A. Structural and Wind Load Tests:
 - 1. Design load/deflection criteria verified from tests per ASTM E 72 "Chamber Method" using a 20 PSF (0.96 kPa) simulated wind load with a deflection limit of L/240.
 - 2. FM Approval Standard 4471: Meets windstorm Class 1A [90] and hailstorm Class 1-SH classifications.
 - 3. Underwriters Laboratory (UL) Uplift Tests for Roof Assemblies: UL Class 90 rated in accordance with UL 580 and shall withstand static uplift load of 140 PSF when tested on 7-foot purlin spacing, and 166 PSF when tested

on 5-foot purlin spacing.

1.5 QUALITY ASSURANCE

- A. Installer Qualifications: Company specializing in installation of the products specified for projects of similar size and scope with minimum five years documented experience.

1.6 DELIVERY, STORAGE, AND HANDLING

- A. Store products in accordance with Manufacturer's written instructions. Store under cover in manufacturer's unopened packaging with labels intact until ready for installation.
- B. Store products off the ground, with panels sloped for drainage and covered to protect factory finishes from damage.
- C. Do not overload roof structure with stored materials. Do not permit material storage or traffic on completed roof surfaces.

1.7 WARRANTY

- A. Manufacturer's Warranty: Manufacturer's two-year limited warranty that panels are free from defects in materials and workmanship, beginning from the date of shipment of panels, but excluding coil coatings (paint finishes) covered under a separate warranty. Warranty does not include interior painted surface of panels.
- B. Submit exterior paint manufacturer's written twenty-year limited warranty on paint finish for adhesion to the substrate and a thirty-year limited warranty on chalk and color fade.

PART 2 – PRODUCTS

2.1 MANUFACTURERS

- A. Acceptable Manufacturer: AEP Span or approved equal.

2.2 METAL WALL PANELS

- A. AEP Span PBR, or approved equal.
 - 1. Prefinished Galvalume® or Zinalume® sheet, ASTM AZ50 made of 55% aluminum, 1.6% silicon and the balance zinc as described in ASTM specification A792.
 - 2. Fabricate panels with sufficient thickness to meet specified UL 90 wind uplift requirements.
 - 3. Fabricated panel with integral continuous overlapping seams.
 - 4. Seam Height: 1-1/4” high ribs at 12” centers with 1/4” high minor ribs at 4” centers.
 - 5. Minimum Thickness: 24 gauge (0.0250 inch) or as indicated on Drawings.
- B. Panel Finish: One coat 70 percent polyvinylidene fluoride, nominal 0.7 mil (0.02

mm) thick, over 0.2 mil (0.005 mm) primer. Color as indicated on Drawings.

- C. Flashing and Trim: Brake-formed sheet metal in the same thickness and finish to match the panels.
- D. Fasteners: Fasteners and accessories for installation of panel system as recommended by panel manufacturer for the system specified.
- E. Sealant: Sealant as recommended by panel manufacturer.

PART 3 – EXECUTION

3.1 EXAMINATION

- A. Examine structural members before beginning installation to ensure that all supporting members are straight, level, plumb and satisfactory for panel installation.
- B. Panel Support Tolerances:
 - 1. Overall rake to rake tolerances plus or minus 2 inches or plus or minus 1 inch at each rake.
 - 2. Vertical deviation from the nominal wall plane of plus or minus 1/8 inch in any 5 foot length, plus or minus 1/4 inch in any 20 foot length and plus or minus 1/2 inch over the entire wall area.
- C. Verify wall openings, curbs, pipes, sleeves, ducts, or vents through wall are solidly set, reglets are in place, and nailing strips located.
- D. Correct defective conditions before beginning Work.
- E. If substrate is the responsibility of another installer, notify Architect of unsatisfactory preparation before proceeding.

3.2 INSTALLATION – GENERAL

- A. Install in accordance with manufacturer's instructions and recommendations including approved shop drawings, installation guidebook and manufacturer's handbook of construction details.
- B. Anchor securely in place using fasteners spaced in accordance with manufacturer's recommendations for design wind load criteria.
- C. Form panel shape as indicated on Drawings, accurate in size, square, and free from distortion or defects.
- D. Install flashing and trim true and in proper alignment.
- E. Protective film on trim shall be removed before exposure to sunlight.
- F. Install sealants where indicated to clean dry surfaces only without skips or voids, to ensure weather tight

3.3 CLEANING

- A. Replace damaged panels and other components of work, which cannot be repaired by

finish touch-up or similar minor repair.

- B. Wipe finished surfaces clean of any filings caused by drilling or cutting to prevent rust staining.

3.4 PROTECTION

- A. Protect installed products until completion of project.
- B. Touch-up, repair, or replace damaged products before Substantial Completion.

END OF SECTION

SECTION 07 43 13
FORMED VENTED SOFFIT PANELS

PART 1 – GENERAL

1.1 SECTION INCLUDES

- A. Metal soffit panels.
- B. Flashing and trim integral to soffit panels.
- C. Fasteners and accessories for installation of panel system.

1.2 SUBMITTALS

- A. Product Data: Metal panels, fasteners, sealants, and accessories.
- B. Shop Drawings:
 - 1. Panel layout and lengths.
 - 2. Trim, flashing, sealant, and other details of installation.
- C. Manufacturer's installation instructions.

1.3 REFERENCE STANDARDS

- A. UL 580 – Uplift Resistance of Roof Assemblies.
- B. UL 1897 – Uplift Test for Roof Covering Systems.
- C. ASTM A 653 – Standard Specification for Steel Sheet, Zinc-Coated (Galvanized) or Zinc-iron Alloy Coated (Galvannealed) by the Hot-Dip Process.
- D. ASTM A 792 – Standard Specification for Steel Sheet, Aluminum-Zinc Alloy Coated Steel by the Hot-Dip Process.
- E. ASTM A 924 – General Requirements for Steel Sheet, Metallic-Coated by the Hot-Dip Process.

1.4 PERFORMANCE REQUIREMENTS

- A. Structural and Wind Load Tests:
 - 1. Design load/deflection criteria verified from tests per ASTM E 72 "Chamber Method" using a 20 PSF (0.96 kPa) simulated wind load with a deflection limit of L/240.
 - 2. FM Approval Standard 4471: Meets windstorm Class 1A [90] and hailstorm Class 1-SH classifications.
 - 3. Underwriters Laboratory (UL) Uplift Tests for Roof Assemblies: UL Class 90 rated in accordance with UL 580 and shall withstand static uplift load of 140 PSF when tested on 7-foot purlin spacing and 166 PSF when tested on 5-foot purlin spacing.

1.5 QUALITY ASSURANCE

- A. Installer Qualifications: Company specializing in installation of the products specified for projects of similar size and scope with minimum five years documented experience.

1.6 DELIVERY, STORAGE, AND HANDLING

- A. Store products in accordance with Manufacturer's written instructions. Store under cover in manufacturer's unopened packaging with labels intact until ready for installation.
- B. Store products off the ground, with panels sloped for drainage and covered to protect factory finishes from damage.
- C. Do not overload roof structure with stored materials. Do not permit material storage or traffic on completed roof surfaces.

1.7 WARRANTY

- A. Manufacturer's Warranty: Manufacturer's two-year limited warranty that panels are free from defects in materials and workmanship, beginning from the date of shipment of panels, but excluding coil coatings (paint finishes) covered under a separate warranty. Warranty does not include interior painted surface of panels.
- B. Submit exterior paint manufacturer's written twenty-year limited warranty on paint finish for adhesion to the substrate, and a thirty-year limited warranty on chalk and color fade.

PART 2 - PRODUCTS

2.1 MANUFACTURERS

- A. Acceptable Manufacturer: AEP Span or approved equal.

2.2 METAL SOFFIT PANELS

- A. AEP Vented Flush-Panel or approved equal.
 - 1. Prefinished Galvalume® or Zincolume® sheet, ASTM AZ50 made of 55% aluminum, 1.6% silicon and the balance zinc as described in ASTM specification A792.
 - 2. Fabricate panels with sufficient thickness to meet specified UL 90 wind uplift requirements.
 - 3. 1" Standoff from Substrate.
 - 4. Thickness: 24 gauge (0.0250 inch).
 - 5. Two pencil ribs.
 - 6. Provide 7.8% Net Free Area.
 - 7. Concealed Fasteners.
 - 8. 12" Net Coverage.

- B. Panel Finish: One coat 70 percent polyvinylidene fluoride, nominal 0.7 mil (0.02 mm) thick, over 0.2 mil (0.005 mm) primer. Color as indicated on Drawings.
- C. Flashing and Trim: Brake-formed sheet metal in the same thickness and finish to match the panels.
- D. Fasteners: Fasteners and accessories for installation of panel system as recommended by panel manufacturer for the system specified.
- E. Sealant: Sealant as recommended by panel manufacturer.

PART 3 EXECUTION

3.1 EXAMINATION

- A. Examine structural members before beginning installation to ensure that all supporting members are straight, level, plumb and satisfactory for panel installation.
- B. Panel Support Tolerances:
 - 1. Overall rake to rake tolerances plus or minus 2 inches, or plus or minus 1 inch at each rake.
 - 2. Vertical deviation from the nominal wall plane of plus or minus 1/8 inch in any 5 foot length, plus or minus 1/4 inch in any 20 foot length, and plus or minus 1/2 inch over the entire wall area.
- C. Verify wall openings, curbs, pipes, sleeves, ducts, or vents through wall are solidly set, reglets are in place, and nailing strips located.
- D. Correct defective conditions before beginning work.
- E. If substrate is the responsibility of another installer, notify Architect of unsatisfactory preparation before proceeding.

3.2 INSTALLATION – GENERAL

- A. Install in accordance with manufacturer's instructions and recommendations including approved shop drawings, installation guidebook and manufacturer's handbook of construction details.
- B. Anchor securely in place using fasteners spaced in accordance with manufacturer's recommendations for design wind load criteria.
- C. Form panel shape as indicated on Drawings, accurate in size, square, and free from distortion or defects.
- D. Install flashing and trim true and in proper alignment.
- E. Protective film on trim shall be removed before exposure to sunlight.
- F. Install sealants where indicated to clean dry surfaces only without skips or voids, to ensure weather tight.

3.3 CLEANING

- A. Replace damaged panels and other components of work, which cannot be repaired by finish touch-up or similar minor repair.
- B. Wipe finished surfaces clean of any filings caused by drilling or cutting to prevent rust staining.

3.4 PROTECTION

- A. Protect installed products until completion of project.
- B. Touch-up, repair, or replace damaged products before Substantial Completion.

END OF SECTION

SECTION 07 92 00
JOINT SEALANT

PART 1 – GENERAL

1.1 SECTION INCLUDES

- A. Furnishing and installing all sealant where indicated on the Drawings.

1.2 RELATED REQUIREMENTS

- A. Division 1.
- B. Section 23 05 00 - Common Work Results for Mechanical.

1.3 SUBMITTALS

- A. Submit the following in accordance with Section 01 33 00.
 - 1. Product Literature for each material used.
 - 2. Manufacturer's surface preparation and installation instructions.

1.4 QUALITY ASSURANCE

- A. Installers: Use only skilled workmen specially trained in the techniques of sealing and familiar with the published recommendations of the manufacturers of the sealants being used.
- B. Verify that sealants are compatible with the substrates and accessory materials provided under other Sections. Notify Engineer of evidence of incompatibility.

1.5 ENVIRONMENTAL CONDITIONS

- A. Install and protect sealants under conditions recommended by the manufacturer and as follows:
 - 1. Do not apply sealant when ambient temperatures are below 40 degrees F, or expected to fall below 40 degrees F before sealant cure is complete.
 - 2. Do not apply sealant to substrates or accessories that are moist.

PART 2 – PRODUCTS

2.1 MATERIALS

- A. Polyurethane-based sealant, Sika Sikaflex 1A, or approved equal, meeting Fed. Spec. TT-S- 00230C, Type II, Class A.
- B. Color shall be gray except where installed against white finished surfaces color shall be white.

2.2 ACCESSORY MATERIALS

- A. Joint Cleaner: Non-corrosive and non-staining type, recommended by sealant manufacturer; compatible with joint forming materials.

PART 3 – EXECUTION

3.1 EXAMINATION

- A. Prior to starting work, carefully inspect installed work of other trades and verify that such work is complete to the point where work of this Section may properly commence. Notify the Authority in writing of conditions detrimental to the proper and timely completion of the Work.
- B. Verify joint dimensions and conditions are acceptable to receive the work of this Section.
- C. Beginning of installation means acceptance.

3.2 PREPARATION

- A. Clean and prepare joints in accordance with manufacturer's instructions. Remove any loose materials and other foreign matter which might impair adhesion of sealant.
- B. Apply masking tightly around joints to protect adjacent surfaces from excess sealant.
- C. Prime as required by manufacturer for proper bond to substrate materials.
- D. Prepare joint to achieve proper sealant width/depth ratios as indicated. Install backer rod where required to achieve correct joint profile.

3.3 INSTALLATION

- A. Install sealant in strict accordance with manufacturer's instructions.
- B. Sealant beads shall have a section as detailed in the Drawings.
- C. Apply sealant within recommended temperature ranges. Consult manufacturer when sealant cannot be applied within recommended temperature ranges.
- D. Tool joints concave, unless otherwise indicated. Finish free of air pockets, foreign embedded matter, ridges and sags.
- E. Coat finished and cured sealant joints with coating system indicated in the Drawings, see Section 09 91 00 - Painting.

3.4 CLEANUP

- A. Clean adjacent surfaces free of excess sealant as the work progresses. Use cleaning agents recommended by the sealant manufacturer.
- B. Upon completion, remove and dispose of masking.

END OF SECTION

SECTION 09 91 00
PAINTING

PART 1 - GENERAL

1.1 SECTION INCLUDES

- A. Surface preparation, priming, and painting of interior and exterior building surfaces.
- B. Applies to both shop fabrication and field construction.

1.2 RELATED REQUIREMENTS

- A. Section 05 12 10 - Structural Steel Framing and Fabrications
- B. Section 06 10 00 - Rough Carpentry
- C. Section 08 00 10 - Doors and Windows
- D. Section 23 05 00 - Common Work Results for Mechanical

1.3 DELIVERY, HANDLING, AND STORAGE

- A. All materials shall be new and be delivered to the project site in unopened containers. Paints shall be stored in a suitable protected area that is heated or cooled as required to maintain temperatures within the range recommended by the paint manufacturer.
- B. Paint containers shall bear labels that plainly show the following:
 - 1. Name or title of material.
 - 2. Federal Specification number, if applicable.
 - 3. Manufacturer's name.
 - 4. Manufacturer's stock number and date of manufacture.
 - 5. Color name and number.
 - 6. Contents by volume, for major pigment and vehicle constituents.
 - 7. Thinning instructions.
 - 8. Application instructions.

1.4 SUBMITTALS

- A. Submit Technical Data Sheets for each type of paint specified and associated thinner. Include specific color for each product.

PART 2 - PRODUCTS

2.1 MATERIALS

- A. Epoxy: Self-priming, two-part epoxy, minimum 80% solids, low VOC compliant. PPG Amerloc 2 VOC or approved equal. Custom tint to ANSI 61 gray.

- B. Cold Galvanizing: Cold application, single product galvanic coating, minimum 95% dry film solids, low VOC compliant. ZRC or approved equal.

PART 3 - EXECUTION

3.1 GENERAL

- A. All materials of a paint system, including primer and finish coats, shall be produced by the same paint manufacturer. Thinners, cleaners, driers, and other additives shall be as recommended by the paint manufacturer of the particular coating.
- B. Paint all exposed surfaces, whether or not designated in "Schedules", except where the natural finish of the material is specifically noted as a surface not to be painted. Where items or surfaces are not specifically mentioned, paint these the same as adjacent or similar materials or areas, or as directed by the Authority. If color or finish is not designated, Contractor shall notify the Authority of these items. Authority will select the color or finish from standard colors available for the materials systems specified.

3.2 EXAMINATION

- A. It is the intent of these Specifications that Contractors and their subcontractors employed on the jobsite will leave the surfaces of their work in such a condition that only minor cleaning, sanding, and filling is required prior to surface preparation and painting. It is the responsibility of the Contractor to inspect and provide substrate surfaces that are prepared in accordance with these Specifications and the printed directions and recommendations of the paint manufacturer whose product is to be applied.

3.3 PROTECTION OF MATERIALS NOT TO BE PAINTED

- A. Remove, mask, or otherwise protect factory finished surfaces, hardware, plumbing fixtures and other surfaces not intended to be painted. Provide drop cloths to prevent paint materials from falling on or marring adjacent surfaces. Protect working parts of mechanical and electrical equipment from damage during surface preparation and painting process. Openings in motors shall be masked to prevent paint and other materials from entering the motors.

3.4 ENVIRONMENTAL CONDITIONS

- A. Apply paint only when the temperature of surfaces to be painted and the surrounding air temperatures are the manufacturer's recommended maximum and minimum allowable range.
- B. Do not apply paint in heavy dust or smoke laden atmosphere.
- C. Do not apply paint in snow, rain, fog, or mist; or when the relative humidity exceeds 85 percent; or to damp or wet surfaces.
- D. Painting may be continued during inclement weather, only if the areas and surfaces to be painted are enclosed and heated within the temperature and humidity limits specified by the paint manufacturer during application and drying periods.

- E. Do not apply paint materials when temperature and humidity conditions can reasonably be predicted to change from manufacturer's application limitations prior to the elapse of adequate drying time.

3.5 SAFETY

- A. Painting shall be performed in strict accordance with the safety recommendations of the paint manufacturer; with the safety recommendations of the National Association of Corrosion Engineers contained in the publication, Manual for Painter Safety; federal, state, and local agencies having jurisdiction.

3.6 PAINT MIXING

- A. Multiple-component coatings shall be prepared using all of the contents of the container for each component as packaged by the paint manufacturer. No partial batches will be permitted. Multiple-component coatings that have been mixed shall not be used beyond their pot life. Contractor shall provide small quantity kits for touch-up painting and for painting other small areas. Only the components specified and furnished by the paint manufacturer shall be mixed. No intermixing of additional components for reasons of color or otherwise, even within the same generic type of coating, will be permitted.
- B. Paint materials shall be kept sealed when not in use.

3.7 LOCATION WHERE PAINTING IS PERFORMED

- A. Surface preparation and painting shall be done at the project site, or in the shop fabrication facility.

3.8 PREPARATION OF SURFACES

- A. General:
 - 1. Perform preparation and cleaning procedures in strict accordance with the paint manufacturer's instructions and as herein specified for each particular substrate condition.
 - 2. Remove all hardware, hardware accessories, machined surfaces, plates, lighting fixtures, and similar items in place and not to be finish painted; or provide surface-applied protection prior to surface preparation and painting operations. Remove, if necessary for the complete painting of the items and adjacent surfaces. Following completion of painting of each space or area, reinstall the removed items by workmen skilled in the trades involved.
 - 3. Clean surfaces to be painted before applying paint or surface treatments. Remove oil and grease prior to mechanical cleaning. Program the cleaning and painting so that contaminants from the cleaning process will not fall onto wet, newly painted surfaces.
- B. Preparation of Structural Steel Surfaces and Doors:
 - 1. Minimum surface preparation shall be Commercial Blast Cleaned per SSPC-SP6 unless specifically indicated otherwise. Remove all oil and grease in accordance with the Solvent Cleaning requirements outlined in

this section.

2. Coating Time: Coat any bare steel within 8 hours or before flash rusting occurs.
3. Sharp edges, surface defects, or protrusions shall be ground flat and smooth. Any welded areas shall be sanded before painting.

C. Preparation of Existing Coated Surfaces:

1. Existing coated or primed surfaces to be repainted or final coated shall be solvent cleaned and freshwater rinsed. Loose, abraded, or damaged coatings shall be cleaned to substrate by Hand or Power Tool, SSPC-SP2 or SSPC-SP3. Surrounding intact coating shall be feathered. One spot coat of the specified primer shall be applied to bare areas overlapping the prepared existing coating. One full finish coat of the specified primer or finish coat(s) shall be applied overall. If an aged, plural-component material is to be top coated, contact the coating manufacturer concerned for additional surface preparation requirements.
2. In the case of an application of a cosmetic coat the exact nature of the existing coatings is not known in all cases; and, while it is assumed that they have oxidized sufficiently to prevent lifting or peeling when over coated with the paints specified, the compatibility shall be checked by application to a small area prior to starting the painting. If lifting or other problems occur, request disposition from the Authority.

D. Solvent Cleaning: Solvent cleaning shall consist of removal of foreign matter such as oil, grease, soil, drawing and cutting compounds, and any other surface contaminants by the use of solvents, emulsions, cleaning compounds, steam cleaning, or similar materials and methods which involve a solvent or cleaning action. This method conforms with SSPC-SP1. For primed or previously painted surfaces the solvent shall be compatible with the existing coating.

3.9 APPLICATION OF PAINT

A. General:

1. Manufacturer's written instructions for applying each type of paint or protective coating shall be furnished to the Authority prior to application. Cleaned surfaces and all coats shall be inspected prior to the succeeding coat. Schedule such inspection with the Authority in advance. Apply all coatings in strict accordance with the paint manufacturer's recommendations, as reviewed by the Authority. Sufficient time shall be allowed between coats to assure thorough drying of previously applied paint.
2. Apply additional coats when undercoats, stains, or other conditions show through the final coat of paint until the paint film is of uniform finish, color, and appearance. Give special attention to ensure that all surfaces including edges, corners, crevices, welds, and exposed fasteners receive a dry film thickness equivalent to that of flat surfaces.

B. Application:

1. Paint surfaces behind movable equipment and furniture the same as similar exposed surfaces. Paint surfaces behind permanently fixed equipment or furniture with prime coat only before final installation of equipment.
2. Paint the back sides of access panels and removable or hinged covers, locker doors, etc., to match the exposed surfaces.
3. Finish exterior doors and frames, on tops, bottoms, and side edges, the same as the exterior faces, unless otherwise indicated.
4. Sand lightly between each succeeding coat.
5. Spray finish metal doors and frames and similar surfaces to achieve finishes that are completely void of brush stroke tracks and marks.
6. Units to be bolted together and to structures shall be painted and paint shall be fully cured prior to assembly or installation.

C. Film Thickness:

1. Coverage is listed as total minimum dry film thickness in mils (DFT). The number of coats is the minimum required irrespective of the coating thickness. Additional coats may be required to obtain the minimum required paint thickness, depending on method of application, differences in manufacturers, products, and atmospheric conditions. Maximum film build per coat shall not exceed the coating manufacturer's recommendations.
2. All surfaces shall be visually inspected to ensure proper and complete coverage has been attained.
3. Particular attention shall be given edges, angles, flanges, etc. Where insufficient film thicknesses are likely to be present, ensure proper millage in these areas.

D. Damaged Coatings:

1. Damaged coatings, pinholes, and holidays shall have the edges feathered and repaired in accordance with the recommendations of the paint manufacturer, as reviewed by the Authority.
2. All finish coats, including touch-up and damage-repair coats shall be applied in a manner which will present a uniform texture and color-matched appearance.

E. Unsatisfactory Application:

1. If the item has an improper finish color, or insufficient film thickness, the surface shall be cleaned and top coated with the specified paint material to obtain the specified color and coverage. Specific surface preparation information to be secured from the coating manufacturer and the Authority.

2. All visible areas of chipped, peeled, or abraded paint shall be hand- or power-sanded feathering the edges. The areas shall then be primed and finish coated in accordance with the Specifications. Depending on the extent of repair and its appearance, a finish sanding and topcoat may be required by the Authority.
3. Work shall be free of runs, bridges, shiners, laps, or other imperfections. Evidence of these conditions shall be cause for rejection.
4. Any defects in the coating system shall be repaired by the Contractor per written recommendations of the coating manufacturer.

3.10 SHIPPING

- A. In all cases where pre-coated items are to be shipped to the jobsite, all efforts shall be made to protect the coating from damage. Coated items shall be battened to prevent abrasion. Contractor shall use non-metallic or padded slings and straps in handling. Items will be rejected for excessive damage, in the opinion of the Authority.

3.11 SCHEDULING PAINTING

- A. Apply the first coat material to surfaces that have been cleaned, pretreated, or otherwise prepared for painting as soon as practicable after preparation and before subsequent surface deterioration.
- B. Allow sufficient time between successive coatings to permit proper drying. Do not recoat until paint has dried to where it feels firm, does not deform or feel sticky under moderate thumb pressure, and the application of another coat of paint does not cause lifting or loss of adhesion of the undercoat.

3.12 CLEANUP

- A. All cloths and waste that might constitute a fire hazard shall be placed in closed metal containers or destroyed at the end of each day. Upon completion of the work, all staging, scaffolding, and containers shall be removed from the site or destroyed in a legal manner. Paint spots, oil, or stains upon adjacent surfaces and floors shall be completely removed, and the entire job left clean and acceptable to the Authority.
- B. Upon completion of painting work, clean window glass and other paint-spattered surfaces. Remove spattered paint by proper methods of washing and scraping, using care not to scratch or otherwise damage finished surfaces.

3.13 PROTECTION

- A. Protect work of other trades, whether to be painted or not, against any damage by painting and finishing work. Correct any damage by cleaning, repairing or replacing, and repainting as acceptable to the Authority.
- B. At the completion of work of other trades, touch up and restore all damaged or defaced painted surfaces.

END OF SECTION

SECTION 21 13 30

HIGH PRESSURE WATER MIST FIRE SUPPRESSION

Notes:

- 1) *All paragraphs below shown in light italic text reference work that was performed as part of the prior module assembly contract and are included here for reference only.*
- 2) *All paragraphs below shown in standard text are to be performed under this contract.*
- 3) *Convergint (formerly ATS Alaska) was the subcontractor responsible for installation and certification of the module fire suppression system under the module assembly contract. Approved submittals for the original installation will be made available to the successful bidder upon request.*

PART 1 - GENERAL

1.1 SCOPE OF WORK

- A. *The work involves design, installation, testing, and certification of an automatic fire suppression system for two power generation modules. The modules will each contain three diesel engine generators as indicated.*
- B. *The modules will be completely assembled off-site (shop fabricated), not field constructed in the communities of Napaskiak and Rampart. All fire suppression system installation, and the initial testing will occur off site and shall include but not be limited to:*
 1. *Design system in accordance with the latest adopted editions of all applicable codes and standards, manufacturer's requirements, these specifications, and the Drawings.*
 2. *Obtain a State of Alaska, Fire Marshal Plan Review Permit.*
 3. *Furnish and install a complete system.*
 4. *Program fire control panel.*
 5. *Acceptance testing and certification of completed system.*
 6. *Preliminary operation training with Authority staff.*
 7. *Preparation for shipping.*
 8. *Operation and Maintenance Manuals including as-built drawings..*
- C. *Upon acceptance of shop fabrication installation and testing by the Authority, one module will be shipped to Napaskiak, Alaska, and one module will be shipped to Rampart, Alaska, for permanent installation and commissioning under a separate on-site contract. All final system testing, certification, commissioning, and training will occur on-site in these communities and will include but not be limited to:*
 1. *Filling and charging system.*
 2. *Final acceptance testing and certification of completed system.*
 3. *Minimum four hours operation training with local operators and Authority staff.*

1.2 RELATED REQUIREMENTS

- A. *Division 1.*
- B. *Division 23.*
- C. *Division 26.*

1.3 QUALITY ASSURANCE

- A. *All equipment shall be new and shall be listed for the intended application. The entire system shall be designed and fabricated in accordance with recognized and acceptable engineering and industry practices.*
- B. *Design shall be prepared by a registered mechanical engineer or technician with minimum NICET Level 3 certification. Designer shall have an appropriate State of Alaska design permit.*
- C. *The Contractor shall be authorized by the fire suppression system manufacturer to furnish and install the specified system. Field installation shall be performed by technicians certified by the manufacturer to install the specified system.*

1.4 REFERENCED STANDARDS:

- A. *National Fire Protection Association (NFPA) 750: Standard on Water Mist Fire Protection Systems.*
- B. *Underwriters Laboratories (UL) UL 864 Control Units for Fire Protective Signaling Systems*
- C. *National Fire Protection Association (NFPA) NFPA 72 National Fire Alarm Code*
- D. *National Electrical Manufacturer's Association (NEMA).*

1.5 SUBMITTALS

- A. *Provide submittals in the manner described herein and in Division 1.*
- B. *Provide submittals for all products and systems described in Division 21 specifications and shown on the Drawings to demonstrate compliance with the requirements of the project. Submittal to include:*
 - 1. *Manufacturer, model numbers and quantity of each device.*
 - 2. *Manufacturer and model of control panel, including installed options.*
 - 3. *Agent piping layout including size and quantity of nozzles.*
 - 4. *Calculations.*
 - 5. *Shop drawings shall indicate compliance with all requirements of the specifications and shall contain at a minimum:*
 - a. *Floor Plans and Isometrics for agent piping.*
 - b. *Floor Plans and Diagrams for Wiring complete with circuit designation in accordance with Wire Schedule on the Drawings (A-B-C-D-E).*
 - c. *Panel and device installation details.*
 - d. *Bill of Materials*
 - e. *Installation notes and system Sequence of Operation.*

- C. *Based upon review comments by the Authority, issue final revised submittal including final construction drawings.*
- D. *Submit a copy of State of Alaska, Fire Marshal Plan Review Permit to the Authority.*
- E. *Prior to testing, certification, and training provide Operation and Maintenance Manuals. Manuals to include system description, manufacturer's catalog information, programming, instructions, operations and maintenance literature, Material Safety Data Sheets (MSDS) for extinguishing agent, and as-built drawings of completed system. Deliverables to include one bound copy plus a PDF format electronic file of the entire manual.*

1.6 SUBSTITUTIONS

- A. *All substitutions shall be noted on equipment submittals.*

1.7 WARRANTY

- A. *Division 1 - Closeout Requirements: Warranties.*
- B. *Provide a one-year manufacturer's warranty covering all materials and workmanship of all products supplied. Warranty shall commence from the date of system certification.*

PART 2 - MATERIALS

2.1 FIRE SUPPRESSION AGENT

- A. *A high pressure water mist fire suppression system shall be furnished, Marioff Hi-Fog or approved equal. In order for a substitution of the suppression system to be approved it must have at a minimum the following salient features:*
 - 1) *The system must use water mist as the sole extinguishing agent.*
 - 2) *The system must use high pressure (2,000 PSI nominal) nitrogen as the sole driving agent without the aid of any pumps.*
 - 3) *The system shall be a single pipe system utilizing stainless steel tubing not exceeding 1" outside diameter.*
 - 4) *The complete agent rack including all water and nitrogen storage for one zone of coverage shall not exceed the following dimensions: 4'-6" Long x 1'-4" Wide x 7'-6" High.*

2.2 AGENT RACK

- A. *A floor mounted rack shall be provided that contains the agent cylinders, nitrogen cylinder, and piping. Marioff Hi-Fog MAU 150 FS or approved equal.*
- B. *The rack shall be designed for the appropriate seismic code and shall be adequately anchored to the module structure.*

2.3 FIRE CONTROL PANEL

- A. *The Fire Control Panel shall be a Fike Cheetah XI-50 10-071-R1 or approved equal, and shall contain a microprocessor based Central Processing Unit (CPU). The CPU shall communicate with, supervise and control the following types of equipment used to make up the system: intelligent self-calibrating smoke and flame detectors, addressable modules, annunciators, and other system controlled devices.*

- B. Basic equipment to be included with Fire Control Panel shall be main board with display and keypad, door, hardware, and backbox for panel surface mount installation.*
- C. System Capacity and General Operation*
- 1. The control panel shall be capable of 50 intelligent/addressable devices.*
 - 2. The system shall include two Class B (NFPA Style Y) programmable Notification Appliance Circuits. It shall also include three additional programmable Form-C alarm and trouble relays rated at a minimum of 2.0 amps @ 30 VDC.*
 - 3. The system shall support up to 99 programmable EIA-485 driven relays for an overall system capacity of 301 circuits.*
 - 4. The Fire Control Panel shall include a full featured operator interface control and annunciation panel that shall include a backlit Liquid Crystal Display, individual, color coded system status LEDs, and an alphanumeric keypad for the field programming and control of the fire system.*
 - 5. All programming or editing of the existing program in the system shall be achieved without special equipment, and without interrupting the alarm monitoring functions of the Fire Control Panel.*
 - 6. The Fire Control Panel shall provide the following features:*
 - a. Automatic detect test and drift compensation to extend detector accuracy over life (smoke and flame detectors monitored and automatically calibrated)*
 - b. Sensitivity Test, meeting requirements of NFPA 72, Chapter 5.*
 - c. Maintenance Alert to warn of excessive smoke detector dirt or dust accumulation.*
 - d. System Status Reports to display.*
 - e. Positive Alarm Sequence pre-signal, meeting NFPA 72 3-8.3 requirements.*
 - f. Periodic Detector Test, conducted automatically by software.*
 - g. Pre-alarm for advanced fire warning.*
 - h. Cross Zoning with the capability of: counting two detectors in alarm, two software zones in alarm, or one smoke detector and one thermal detector.*
 - i. Walk Test, with check for two detectors set to same address.*
 - j. Adjustable delay and discharge timers.*
 - k. The detector software shall meet NFPA 72, Chapter 7 requirements and be certified by UL as a calibrated sensitivity test instrument.*
 - l. The detector software shall allow manual or automatic sensitivity adjustment.*
 - m. Event history file in nonvolatile memory.*
 - n. Panel to have abort option to manually prevent release of extinguishing agent.*
 - o. Battery back-up in the event of normal AC power failure.*

- p. *Unit to be able to release extinguishing agent in at least two independent hazard zones.*

2.4 SECONDARY POWER SOURCE BATTERIES

- A. *Secondary power shall be provided by 12 volt batteries. The batteries shall be sealed and shall be completely maintenance free.*
- B. *Batteries shall have sufficient capacity to power the fire system for not less than twenty-four hours standby operation plus 30 minutes of alarm upon a normal AC power failure. Note that this is in excess of minimum NFPA requirements.*

2.5 HEAT DETECTOR

- A. *UL Listed, adjustable temperature heat detector. Fike 60-1039 or approved equal. Set to activate at 135°F for normal temperature and 190°F for high temperature.*

2.6 FLAME (OPTICAL) DETECTOR

- A. *UL Listed, flame detectors shall be multi-spectrum, UV/Dual IR/Vis electro-optical, automatic calibrating, digital fire detectors. Honeywell FS-20X or approved equal. Install on swivel mount.*

2.7 SMOKE (PHOTOELECTRIC) DETECTOR

- A. *UL Listed, automatic calibrating type, photoelectric smoke detector. Detector to be addressable and provide analog signal to the control panel which may be used for maintenance of detector. Fike 63-1052 or approved equal.*

2.8 ANNUNCIATORS

- A. *Interior Annunciator (Alarm and Discharge) - UL Listed, Horn/strobe combination, minimum 75 candela. Gentex GEC3-24WR or approved equal.*
- B. *Exterior Annunciator (Alarm) - Weatherproof, UL Listed horn/strobe combination, minimum 75 candela. Gentex WGEC24-75WR or approved equal.*
- C. *Exterior Strobe (Discharge) - Weatherproof, UL Listed strobe, minimum 75 candela. Gentex WGES24-75WR or approved equal.*

2.9 MANUAL PULL STATION

- A. *Manual pull station(s) shall be UL Listed, addressable, double action, and provide visible indication that station has been operated.*
1. *FIRE SUPPRESSION RELEASE: Honeywell MS-2H or approved equal.*

2.10 DEVICE MONITORING MODULES

- A. *UL Listed modules designed for use with intelligent and addressable equipment as required. Fike Series 55 or approved equal.*

2.11 PLACARDS

- A. *Provide placards in compliance with NFPA as required. Provide additional warning placards as indicated on the plan in accordance with the Placard Schedule.*

2.12 RACEWAYS AND CONDUCTORS

- A. *Route all wiring in separate dedicated raceways for all fire suppression system wiring at no cost to Contractor. All raceways shall be electrical metallic tubing (EMT). All raceways, junction boxes, pull boxes, and cover plates shall be painted red.*
- B. *All conductors shall be soft drawn copper, Type XHHW insulation; 600V and 75C rated; gauge and color as indicated by service in accordance with the following schedule:*
 - 120V AC Power - 12 AWG, stranded, color per station service scheme.*
 - 24V DC Power, Detection, and Alarm Circuits - 14 AWG, color in accordance with the Wire Schedule.*

2.13 NOZZLES

- A. *In Total Flooding and Local Application zones nozzles shall be open spray head type, Marioff 4S IMC 8MB 1100 or approved equal.*

2.14 PIPING

- A. *Contractor shall furnish, install, and pressure test agent discharge tubing/piping in accordance with manufacturer's recommendations.*

2.15 SUPPORT

- A. *Contractor shall furnish and install industry standard hangers for agent discharge piping, raceways, panel and all devices.*

2.16 FITTINGS, VALVES, CONTROLS, AND DEVICES

- A. *Contractor shall furnish and install all required fittings, valves, control devices, and accessories as required to provide the types of coverage required for each zone as indicated on the Drawings.*

PART 3 - EXECUTION

3.1 DESIGN

- A. *The system shall be designed and installed in accordance with the latest adopted editions of all applicable codes and standards and manufacturer's requirements.*
- B. *Design fire suppression system with two zones of coverage as shown on the Drawings.*
 - 1. *Zone 1 (Generation Room) shall contain agent rack, discharge piping and nozzles. Two flame detectors shall be cross-zoned so that any one detector will set off alarm and shut-down generators. Any second detector will begin a 30 second countdown to agent release. Two high temperature heat detectors shall be cross-zoned in the same sequence as the flame detectors. Exit shall have a manual "FIRE SUPPRESSION RELEASE" pull station which will begin a 30 second countdown to agent release when activated.*
 - 2. *Zone 2 (Control Room) shall contain the control panel, one smoke detector and one normal temperature heat detector. Either detector will set off alarm and will shut-down generators. Exit shall have a manual "FIRE SUPPRESSION RELEASE" pull station which will begin a 30 second countdown to agent release when activated.*
- C. *Provide annunciators and other devices where specifically indicated on the Drawings.*

3.2 INSTALLATION - GENERAL

- A. The system shall be installed in accordance with the Contract Documents, the approved submittal, and all manufacturer's requirements.*
- B. Contractor shall perform all work with skilled craftsmen specializing in said work with all required certifications. Install all materials in a neat, orderly, and secure fashion, as required by these specifications, manufacturer's requirements, and commonly recognized standards of good workmanship.*

3.3 INSTALLATION – SHOP MODULE ASSEMBLY

- A. Upon completion of shop testing, all water shall be drained and/or blown out of the system to prevent freeze damage and the batteries shall be disconnected.*
- B. The system shall be left with one fully charged nitrogen cylinder installed in the rack plus one fully charged spare nitrogen cylinder shipped loose with the module.*

3.4 INSTALLATION – ON SITE

- A.** The final testing and commissioning will occur on site and will include but not be limited to:
 - 1. Filling and charging systems.
 - 2. Final acceptance testing and certification of completed systems.
 - 3. Minimum four hours operation training on site with local operators and Authority staff.
 - 4. Verify that the system has one fully charged nitrogen cylinder installed in the rack plus one fully charged spare nitrogen cylinder.

END OF SECTION

SECTION 23 05 00

COMMON WORK RESULTS FOR MECHANICAL

PART 1 - GENERAL

1.1 SCOPE OF WORK

- A. The work to be included in these and all other mechanical subsections shall consist of providing, installing, adjusting and setting into proper operation complete and workable systems for all items shown on the Drawings, described in the specifications or reasonably implied. This shall include the planning and supervision to coordinate the work with other crafts and to maintain a proper time schedule for delivery of materials and installation of the work.
- B. Local Conditions: The Contractor shall thoroughly familiarize himself with the work as well as the local conditions under which the work is to be performed. Schedule work with regard to seasons, weather, climate conditions, and all other local conditions which may affect the progress and quality of work.
- C. See Division 1 of which contain information and requirements that apply to work specified herein.
- D. In addition to general mechanical requirements this Section includes specific requirements for:
 - 1. Painting and marking.
 - 2. Valve tags, signs, and placards.
 - 3. Flashing and sealing.

1.2 RELATED REQUIREMENTS

- A. Division 1.
- B. All other Division 23 Specifications.
- C. Divisions 21 and 26.

1.3 CODES AND STANDARDS

- A. Codes: Perform all work in strict accordance with all applicable national, state, and local codes; including, but not limited to the latest legally enacted editions of the following specifically noted requirements:
 - 1. International Fire Code - IFC.
 - 2. International Building Code - IBC .
 - 3. National Fire Protection Association (NFPA) NFPA 30 and NFPA 37.
- B. Standards: Reference to the following standards infers that installation, equipment, and materials shall be within the limits for which it was designed, tested, and approved, in conformance with the current publications and standards of the following organizations:

1. American National Standards Institute – ANSI.
2. American Society for Testing and Materials – ASTM.
3. American Petroleum Institute (API).
4. American Society of Testing and Materials (ASTM).
5. American Society of Mechanical Engineers (ASME).
6. American Welding Society (AWS).
7. Underwriters Laboratory - UL.

1.4 QUALITY ASSURANCE

- A. Division 1 – Quality Control.
- B. Perform all work in accordance with above referenced codes and standards which are referenced to establish minimum requirements.
 1. If the Contractor observes that the Drawings and/or Specifications are at variance with such codes and regulations, he shall promptly notify the Authority in writing.
 2. Should the Contractor perform any work in non-compliance with the above-mentioned codes and regulations without such notice to the Authority, the Contractor shall bear all costs arising therefrom.
- C. In addition, perform all work in accordance with the specific requirements of all Division 23 sections which follow. Wherever the specifications require higher grades of material or workmanship than required by the codes the specifications shall prevail.
- D. Perform all work in a neat and workmanlike manner using skilled craftsmen who are qualified and experienced in the specific type of work.
- E. Test all work as required by the specifications. Document all testing and submit results in accordance with specifications.
- F. Perform pipe welding with experienced welder with current API or equivalent certification for pipe welding in all positions.

1.5 SPECIAL CONDITIONS AND REQUIREMENTS

- A. Ensure that the appropriate safety measures are implemented and that all workers are aware of the potential hazards from electrical shock, burn, noise, rotating fans, pulleys, belts, hot piping, etc. associated with working near power generation and related equipment.

1.6 DRAWINGS, SPECIFICATIONS & SYMBOLS

- A. The Drawings and Specifications are complementary; what is shown on one is as binding as if called for in both. Do not scale the Drawings. Locations of devices, fixtures, and equipment are approximate unless dimensioned.
- B. Drawing symbols used for basic materials, equipment and methods are commonly used by the industry and should be universally understood. Special items are identified by a

supplementary list of graphical illustrations, or called for on the Drawings or in the specifications.

1.7 SPECIFIC TERMINOLOGY

- A. Streamlining: In many instances, the products, reference standards, and other itemized specifications have been listed without verbiage. In these cases, it is implied that the Contractor shall provide the products and perform in accordance with the references listed.
- B. "Furnish" means to purchase material as shown and specified, and cart the material to an approved location at the site or elsewhere as noted or agreed to be installed by supporting crafts.
- C. "Install" means to set in place and connect, ready for use and in complete and properly operating finished condition, material that has been furnished.
- D. "Provide" means furnish all products, labor, sub-contracts, and appurtenances required and install to a complete and properly operating, finished condition.
- E. "Product" is a generic term which includes materials, equipment, fixtures, and any physical item used on the project.
- F. "Accessible" means arranged so that an appropriately dressed man 6-foot 2 inches tall, weighing 250 pounds, may approach the area in question with the tools and products necessary for the work intended, and may then position himself to properly perform the task to be accomplished, without disassembly or damage to the surrounding installation.
- G. "Serviceable" means arranged so that the component or product in question may be properly removed and replaced without disassembly, destruction, or damage to the surrounding installation.

1.8 SUBMITTALS – GENERAL REQUIREMENTS

- A. Provide submittals for all products and systems described in Division 23 specifications and shown on the Drawings to demonstrate compliance with the requirements of the project. Provide submittals in the manner described herein and in Division 1 with an index following specification format and with item by item identification.
- B. Submittal review is for general design and arrangement only and does not relieve the Contractor from any of the requirements of the Contract Documents. Submittals will not be checked for quantity, dimension, fit or proper technical design of manufactured equipment. Where deviations of substitute product or system performance have not been specifically noted in the submittal by the Contractor, provision of a complete and satisfactory working installation of equal quality to system specified is the sole responsibility of the Contractor.
- C. Submittals shall demonstrate compliance with the requirements of the project. Furnish all relevant data as appropriate including but not limited to:

8. Manufacturer's name and address, and supplier's name, address, and phone number.
 9. Catalog designation or model number with rough-in data and dimensions.
 10. Operation characteristics.
 11. Complete customized listing of characteristics required. Indicate whether item is "As Specified" or "Proposed Substitution." Indicate any deviations on submittal. Mark out all non- applicable items. The terminology "As Specified" used without this customized listing is not acceptable.
 12. Wiring diagrams for the specific system.
 13. Coordination data to check protective devices.
 14. Shop Drawings.
- D. Provide submittals for all materials and equipment in the Division 23 specification sections which follow and submit under that specification section.
- E. Equipment: Submit manufacturers catalog literature for each item indicated on the Mechanical Schedules on Sheet M1.1 under the Division 23 Sections that follow. See specific requirements under each section.

1.9 SUBMITTALS UNDER THIS SECTION

- A. Product Data: Submit manufacturers catalog literature for paint, caulking, flashing, pipe marking, and all other items specified under this Section.
- B. Valve Tags: Provide submittal for specific tags as indicated on the Schedule on Sheet M1.2.
- C. Signs and Placards: Provide submittal for signs and placards as indicated on the Schedule on Sheet M1.2.
- D. Qualifications: Submit a copy of current certification for the party or parties who will perform pipe welding.

1.10 RECEIVING AND HANDLING MATERIAL

- A. See General Conditions and Division 1 regarding material handling.
- B. Deliver packaged materials to the jobsite in unbroken packaging with manufacturer's label, and store to facilitate inspection and installation sequence.
- C. Protect all materials and equipment during the duration of construction work against contamination and damage. Replace or repair to original manufactured condition any items damaged during construction. Immediately report any items found damaged to the Authority prior to commencing construction.

1.11 TIMELY EXECUTION OF WORK

- A. The work must be expedited and close coordination will be required in executing the work. The various trades shall perform their portion of the work at such times as directed so as to meet scheduled completion dates, and to avoid delaying any other trade.
- B. The Authority will set up completion dates. Each Contractor shall cooperate in establishing these times and locations and shall process his work so as to ensure the proper execution of it.

1.12 LAYOUT AND COORDINATION OF WORK

- A. Drawings are partly diagrammatic and it is not the intent to show in detail all features of work or exact physical arrangement of equipment. The locations of piping and equipment are approximate unless dimensioned. The exact locations and routing of piping shall be governed by structural conditions and physical interferences and by the location of mechanical terminations on equipment. Equipment shall be located and installed so that it will be readily accessible for operation and maintenance.
- B. If piping is placed incorrectly with respect to equipment connections or if equipment connections are relocated without appropriate changes in the mechanical work and the resulting work is not coordinated, the work affected shall be removed and re-installed at the Contractor's expense, even if removal and replacement of portions of work by other trades is necessary.

1.13 COOPERATION AND CLEANING UP

- A. The Contractor for the work under each section of the specifications shall coordinate his work with the work described in all other sections of the specifications, and shall carry on his work in such a manner that none of the work under any section of these specifications shall be compromised, hindered, or delayed at any time.
- B. At all times during the progress of the work, the Contractor shall keep the premises clean and free of unnecessary materials and debris. The Contractor shall, on direction at any time from the Authority, clear any designated area or areas of materials and debris. On completion of any portion of the work, the Contractor shall remove from the premises all tools and machinery and all debris occasioned by the work, leaving the premises free of all obstructions and hindrances.

1.14 SPECIAL CONDITIONS AND REQUIREMENTS

- A. Ensure that the appropriate safety measures are implemented and that all workers are aware of the potential hazards from electrical shock, burn, noise, rotating fans, pulleys, belts, hot piping, etc. associated with working near power generation and related equipment.

1.15 PROJECT RECORD DRAWINGS

- A. In accordance with the requirements of Division 1 maintain record documents at the project site and make available for review by the Authority upon request.

- B. Mark up a clean set of drawings as the work progresses to show the dimensioned location and routing of all mechanical work which will become permanently concealed. Show routing of work in concealed below grade or in blind spaces within the building.
- C. At completion of project, deliver record documents in accordance with Division 1.

1.16 MECHANICAL SYSTEMS TESTING AND REPORTING REQUIREMENTS

- A. Division 1 – Quality Control
- B. Provide pressure tests of piping and tanks as indicated on the Drawings and in the Division 23 sections that follow.
- C. Notify the Authority in writing seven (7) days in advance of pressure tests. The Authority shall have the option to be present at all testing.
- D. Provide written documentation of all pressure tests. The Contractor may use their own test forms or upon request the Authority can provide forms for common tests. Test reports shall include at a minimum the following information: item or system identification, gauge pressure, air temperature, time, date, signature of person performing test, and photographs of testing in progress.
- E. Cut out or disassemble all leaking joints. Repair and re-test until system proves leak-free. Retesting after the repair of defects shall be performed at no cost to the Authority.
- F. Submit completed results of final successful tests along with photographs to the Authority for approval prior to Substantial Completion.

1.17 MECHANICAL INSTRUMENTATION CALIBRATION REQUIREMENTS

- A. Division 1 – Quality Control
- B. Calibrate all mechanical and electronic measuring devices as indicated in the Division 23 sections that follow.
- C. Devices requiring calibration shall include but not be limited to: tank level gauges, pressure vacuum whistle vents, liquid level probes, float switches, thermometers, and temperature transmitters (sensors).

1.18 SUBSTANTIAL COMPLETION

- A. In accordance with Section 01 77 00 - Contract Closeout Procedures, provide advance written notice to the Authority to schedule substantial completion inspection. Submit all required documents and ensure all conditions have been met.
- B. Provide Authority access to the site. Provide on-site transportation, ladders, lifts, etc. for inspection and testing of the work.
- C. Cooperate with the Authority and provide assistance at all times for the inspection of the mechanical work performed under this Contract. Remove covers, operate machinery, or perform any reasonable work which, in the opinion of the Authority, will be necessary to determine the completeness, quality, or adequacy of the work.

- D. Conduct operating tests and demonstrate that all systems operate satisfactorily in accordance with requirements of Contract Documents. Should a portion of installation fail to meet requirements of Contract Documents, repair or replace items failing to meet requirements until items can be demonstrated to comply.
- E. Have instruments available for measuring pressure and temperature. Provide services of qualified technicians familiar with equipment and systems to assist in taking measurements and making tests.
- F. Assist the Authority in instruction of operators on the proper operation and maintenance of all systems and equipment under this contract. Provide services of qualified technicians familiar with each item or system.

1.19 FINAL COMPLETION

- A. In accordance with Section 01 77 00 - Contract Closeout Procedures, provide notification of completion. Submit all required documents and ensure all conditions have been met.

1.20 WARRANTY

- A. In accordance with Section 01 73 00 – Execution Requirements, provide warranties for all systems and equipment.
- B. See Division 23 sections that follow for specific equipment warranty requirements. Wherever the Division 23 specifications have more stringent warranty requirements than Division 1, the Division 23 requirements shall prevail.

PART 2 - PRODUCTS

2.1 MATERIALS AND EQUIPMENT

- A. Provide all equipment and materials required for a complete system.
- B. All equipment and materials supplied under this Contract shall be new unless specifically indicated as existing. Where additional or replacement items are required, provide like items by the same manufacturer to the maximum extent practical.
- C. Install all material and equipment in accordance with manufacturer's installation instructions and recommendations unless specifically indicated otherwise.

2.2 PAINTING

- A. Interior Carbon Steel Pipe – Primer: PPG Multiprime 4160 or approved equal, color gray. Finish: PPG Devguard 4308 or approved equal, color ANSI 61 Gray.
- B. Exterior Carbon Steel Pipe - Cold Galvanizing Compound, ZRC or approved equal.
- C. Touch-up – Cold Galvanizing Compound, ZRC or approved equal.

2.3 PIPE MARKING

- A. Black or white arrows over colored backgrounds, self-adhesive vinyl, Seton arrows on roll or approved equal. Background color scheme to match the colors listed for Specific Function Valve Tags.

2.4 FLASHING AND SEALING

- A. Caulking for Piping - Polyurethane-based sealant, Sika Sikaflex 1A, or approved equal. Color gray.
- B. Caulking for Charge Air Tubing – Silicone-based sealant, rated for intermittent 600F exposure, 3M Ultrapro High Temp Black, or approved equal. Color black.
- C. Flashing - Best Materials Multi-Flash Master Flash or approved equal, Black EPDM. Note that the retro-fit style may be used for convenience.

2.5 VALVE TAGS

- A. Specific Function Valve Tags – For all valves marked with a specific function, provide tags color coded and worded as indicated on the Schedule on Sheet M1.2.
- B. Standard Valve Tags – For all valves not marked with a specific function, provide NO/NC tags as indicated on the schedules. Seton or approved equal.
- C. Install all tags as noted.

2.6 SIGNS AND PLACARDS

- A. Provide decals and sign boards, color coded and worded as indicated on the Schedule on Sheet M1.2. Install as noted.

PART 3 - EXECUTION

3.1 DRAWINGS

- A. The mechanical Drawings are generally diagrammatic and do not necessarily show all features of the required work. Provide all equipment and materials required for a complete system. Complete details of the building which affect the mechanical installation may not be shown. For additional details, see other Drawings which may include electrical, architectural, structural, and civil. Coordinate work under this section with that of all related trades.
- B. Contractor shall field verify all dimensions and conditions prior to start of construction. Immediately contact the Authority for clarification of questionable items or apparent conflicts.

3.2 EXAMINATION

- A. Check materials for damage that may have occurred during shipment. Repair damaged materials as required or replace with new materials.

3.3 CUTTING, REPAIRING, PATCHING, AND FINISHING

- A. Where previously completed building surfaces or other features must be cut, penetrated, or otherwise altered, such work shall be carefully laid out and patched to the original condition. Perform work only with craftsmen skilled in their respective trades.
- B. Do not cut, drill, or notch structural members unless specifically approved by the Authority. Minimize penetrations and disruption of building features.

3.4 PAINTING

- A. Interior Carbon Steel Pipe - Paint all exposed carbon steel pipe and fittings that is not insulated except for engine exhaust. Wire brush and wipe down with solvent. Prime with one coat of alkyd primer and finish with one coat of alkyd enamel, color ANSI 61 Gray.
- B. Exterior Carbon Steel Pipe - Paint all exposed carbon steel pipe and fittings except for engine exhaust. Wire brush and wipe down with solvent. Prime and finish with two coats of cold galvanizing compound.
- C. Touch-up – Touch up paint on fabricated items to match original. Finish all cut ends and damaged surfaces of galvanized and zinc plated supports and fasteners with spray on cold galvanizing compound.

3.5 PIPE MARKING

- A. Install flow arrows on diesel fuel, used oil, cooling, and heat recovery piping. Confirm normal fluid flow direction and install arrows aligned with normal flow. On insulated piping install flow arrows over jackets. Background color scheme to match the colors listed for Specific Function Valve Tags.

3.6 FLASHING AND SEALING

- A. For all penetrations of interior walls and small pipe (less than 2” diameter) penetration of exterior walls, seal with polyurethane caulking all around both surfaces.
- B. For 2” diameter and larger pipe penetration of exterior walls install flashing as indicated on Drawings.

3.7 INSTALLATION OF EQUIPMENT

- A. Unless otherwise indicated, support all equipment and install in accordance with manufacturer's recommendations and approved submittals.
- B. Maintain manufacturer's recommended minimum clearances for access and maintenance.
- C. Where equipment is to be anchored to structure, provide necessary anchoring and vibration isolation devices.
- D. Provide all structural steel, such as angles, channels, beams, etc. required to support all piping, ductwork, equipment and accessories installed under this Division. Use structural supports suitable for equipment specified or as indicated. In all cases, support design will be based upon data contained in manufacturer's catalog.
- E. Openings: Arrange for necessary openings in buildings to allow for admittance and reasonable maintenance or replacement of all apparatus furnished.

3.8 VIBRATION ISOLATION

- A. All vibrating equipment and the interconnecting pipe and ductwork shall be isolated to eliminate the transmission of objectionable noise and vibration to the structure.
- B. Mechanical equipment shall be carefully checked upon delivery for proper mechanical performance, which shall include proper noise and vibration operation.

- C. All installed rotating equipment with excessive noise and/or vibration, which cannot be corrected in place, shall be replaced at no cost to the Authority.

END OF SECTION

SECTION 23 05 29

HANGERS AND SUPPORTS FOR PIPING AND EQUIPMENT

PART 1 - GENERAL

1.1 SUMMARY

- A. Section includes:
 - 1. Pipe hangers and supports.
 - 2. Hanger rods.
 - 3. Formed steel channel.

1.2 RELATED REQUIREMENTS

- A. Section 23 05 00 – Common Work Requirements for Mechanical
- B. Section 23 21 13 - Hydronic Piping
- C. Section 23 11 13 - Fuel and Lube Oil Piping
- D. Section 23 35 16.10 - Engine Exhaust and Crank Vent Piping
- E. Section 26 05 29 - Hangers and Supports for Electrical Systems

1.3 REFERENCES

- A. American Society of Mechanical Engineers:
 - 1. ASME B31.1 - Power Piping.
 - 2. ASME B31.9 - Building Services Piping.
- B. ASTM International:
 - 1. ASTM F708 - Standard Practice for Design and Installation of Rigid Pipe Hangers.
- C. American Welding Society:
 - 1. AWS D1.1 - Structural Welding Code - Steel.
- D. Manufacturers Standardization Society of the Valve and Fittings Industry:
 - 1. MSS SP 58 - Pipe Hangers and Supports - Materials, Design and Manufacturer.
 - 2. MSS SP 69 - Pipe Hangers and Supports - Selection and Application.
 - 3. MSS SP 89 - Pipe Hangers and Supports - Fabrication and Installation Practices.

1.4 SUBMITTALS

- A. Provide submittals for all products and systems under this Section in accordance with Section 23 05 00 - Common Work Results for Mechanical and Division 1.
- B. Shop Drawings: Submit shop drawings for fabricated supports. Note that if all items will be fabricated exactly as indicated on the Drawings, the design Drawings can be submitted in lieu of shop drawings.
- C. Product Data:

1. Hangers and Supports: Submit manufacturers catalog data including load capacity. Indicate finish for interior and exterior applications.

1.5 QUALITY ASSURANCE

- A. Division 1 – Quality Control
- B. Conform to applicable code for support of piping and equipment.

1.6 QUALIFICATIONS

- A. Manufacturer: Company specializing in manufacturing Products specified in this section with minimum three years documented experience.
- B. Installer: Company specializing in performing Work of this section.

1.7 DELIVERY, STORAGE, AND HANDLING

- A. Accept materials on site in original factory packaging, labeled with manufacturer's identification.
- B. Protect from weather and construction traffic, dirt, water, chemical, and damage, by storing in original packaging.

1.8 FIELD MEASUREMENTS

- A. Verify field measurements prior to fabrication.

PART 2 - PRODUCTS

2.1 STRUCTURAL STEEL

- A. Miscellaneous shapes and plate: ASTM A-36.
- B. Rectangular tubing: ASTM A-500 Grade B.
- C. Structural Pipe: ASTM A-53 or ASTM A-106B.
- D. Paint as indicated.

2.2 PIPE HANGERS AND SUPPORTS

- A. Support equipment and raceways on strut, brackets, trapeze hangers, or as detailed. Anvil, B-Line, Grinnell, Unistrut, or approved equal.

2.3 FORMED STEEL CHANNEL

- A. Strut: Cold formed mild steel channel strut, pre-galvanized finish and slotted back unless specifically indicated otherwise.
- B. Standard Strut: 12 gauge thick steel, 1-5/8" x 1-5/8", B-line B22-SH-Galv or equal.
- C. Double Strut: 12 gauge thick steel, 1-5/8" x 3-1/4", B-line B22A-SH-Galv or equal.
- D. Shallow Strut: 14 gauge thick steel, 1-5/8" x 13/16", B-line B54-SH-Galv or equal.
- E. On all exterior installations provide hot dip galvanized strut and fittings.

2.4 FITTINGS AND ACCESSORIES

- A. Provide fittings, brackets, channel nuts, and accessories designed specifically for use with specified channel strut. Zinc plated carbon steel except for exterior installations provide hot dip galvanized.
- B. Pipe Clamps: Two piece pipe clamp designed to support pipe tight to strut, B-line as indicated on the Pipe/Tubing Strut Clamp Schedule on Sheet M1.1 or approved equal. On copper tubing provide copper plated carbon steel clamps with dielectric cushion insert. On interior steel piping provide zinc plated carbon steel clamps. On exterior steel piping provide hot dip galvanized clamps.
- C. Pipe Straps: Two-hole steel pipe strap. Zinc plated carbon steel except for exterior installations provide hot dip galvanized.

2.5 FASTENERS

- A. All bolts, nuts, and washers to be zinc plated carbon steel except as specifically noted otherwise.
- B. On exterior installations provide hot dip galvanized steel bolts, nuts, and washers.
- C. On exhaust piping flanges provide plain carbon steel (black) or stainless steel bolts, nuts, and washers. Coat with high temperature anti-seize prior to assembly.
- D. Hanger Rods: Continuous threaded rod. Zinc plated carbon steel except for exterior installations provide hot dip galvanized.
- E. Provide stainless wood screws and sheet metal screws where specifically indicated on the Drawings.

PART 3 - EXECUTION

3.1 EXAMINATION

- A. Check materials for damage that may have occurred during shipment. Repair damaged materials as required or replace with new materials.

3.2 PREPARATION

- A. Obtain permission from the Authority before drilling or cutting structural members.
- B. Coat all black, stainless steel, and galvanized bolts with anti-seize compound prior to assembly.

3.3 INSTALLATION - EQUIPMENT

- A. Support equipment as shown on Drawings using specified supports and fasteners.
- B. Anchor equipment weighing more than 100 pounds to the building structure to resist lateral earthquake forces.
- C. Total lateral (earthquake) force shall be 1.00 times the equipment weight acting laterally in any direction through the equipment center of gravity. Provide adequate backing at structural attachment points to accept the forces involved.
- D. Provide equipment supported by flexible isolation mounts with earthquake restraining supports positioned as close to equipment as possible without contact in normal operation

(earthquake bumpers). The maximum lateral displacement due to the computed earthquake force from above shall not exceed 1.5 inches.

3.4 INSTALLATION - PIPE HANGERS AND SUPPORTS

- A. Support piping as shown on Drawings using specified supports and fasteners. If not detailed on Drawings, support from structural members with pipe hangers, clamps or pipe straps specifically intended for the application.
- B. Pipe clamps and hangers for steel pipe shall be zinc plated carbon steel except on exterior installations hot dip galvanized.
- C. Copper tube shall be isolated from clamps, hangers, and strut with two layers of 10 mil vinyl pipe wrap.
- D. Independently support pumps and equipment. Do not support piping from connections to equipment.
- E. Support horizontal piping as scheduled.
- F. Install hangers with minimum 1/2 inch space between finished covering and adjacent work.
- G. Place hangers within 12 inches of each horizontal elbow or as indicated.
- H. Use hangers with 1-1/2 inch minimum vertical adjustment.
- I. Where piping is installed in parallel and at same elevation, provide multiple pipe or trapeze hangers.
- J. Support riser piping independently of connected horizontal piping.
- K. Design hangers for pipe movement without disengagement of supported pipe.
- L. Provide clearance in hangers and from structure and other equipment for installation of insulation. Refer to Section 23 07 19.

3.5 SCHEDULES

- A. Copper Tube and Steel Pipe Hanger Spacing:

PIPE SIZE Inches	Copper Tube Maximum Hanger Spacing (Ft)	Steel Pipe Maximum Hanger Spacing (Ft)	Copper Tube Hanger Rod Diameter (In)	Steel Pipe Hanger Rod Diameter (In)
1/2 & 3/4	5	7	3/8	3/8
1 & 1-1/4"	6	7	3/8	3/8
1-1/2	8	9	3/8	3/8
2	8	10	3/8	3/8
3	10	10	1/2	1/2
4	12	10	1/2	5/8

END OF SECTION

SECTION 23 07 19
PIPING INSULATION

PART 1 - GENERAL

1.1 SUMMARY

- A. Section includes: Piping and equipment insulation, jackets, and accessories.

1.2 RELATED REQUIREMENTS

- A. Section 23 05 00 – Common Work Requirements for Mechanical.
- B. Section 23 05 29 - Hangers and Supports for Piping and Equipment.
- C. Section 23 21 13 – Hydronic Piping.
- D. Section 23 35 16.10 - Engine Exhaust and Crank Vent Piping.

1.3 REFERENCES

- A. ASTM International:
 - 1. ASTM B209 - Standard Specification for Aluminum and Aluminum-Alloy Sheet and Plate.
 - 2. ASTM C450 - Standard Practice for Fabrication of Thermal Insulating Fitting Covers for NPS Piping, and Vessel Lagging.
 - 3. ASTM C547 - Standard Specification for Mineral Fiber Pipe Insulation.
 - 4. ASTM C585 - Standard Practice for Inner and Outer Diameters of Rigid Thermal Insulation for Nominal Sizes of Pipe and Tubing (NPS System).
 - 5. ASTM C1136 - Standard Specification for Flexible, Low Permeance Vapor Retarders for Thermal Insulation.

1.4 SUBMITTALS

- A. Provide submittals for all products and systems under this Section in accordance with Section 23 05 00 - Common Work Results for Mechanical and Division 1.
- B. Product Data: Submit product description, thermal characteristics and list of materials and thickness for each service, and location.

1.5 QUALITY ASSURANCE

- A. Division 1 – Quality Control
- B. Pipe insulation maximum flame spread index of 25 and maximum smoke developed index of 50 in accordance with ASTM E84.
- C. Pipe insulation manufactured in accordance with ASTM C585 for inner and outer diameters.
- D. Factory fabricated fitting covers manufactured in accordance with ASTM C450.

1.6 QUALIFICATIONS

- A. Manufacturer: Company specializing in manufacturing products specified in this section.
- B. Applicator: Company specializing in performing work specified in this section.

1.7 DELIVERY, STORAGE, AND HANDLING

- A. Accept materials on site in original factory packaging, labeled with manufacturer's identification, including product density and thickness.
- B. Protect insulation from weather and construction traffic, dirt, water, chemical, and damage, by storing in original wrapping.

1.8 ENVIRONMENTAL REQUIREMENTS

- A. Install insulation only when ambient temperature and humidity conditions are within range recommended by manufacturer.

1.9 FIELD MEASUREMENTS

- A. Verify field measurements prior to fabrication.

PART 2 - PRODUCTS

2.1 HYDRONIC (COOLANT/HEAT RECOVERY) PIPE INSULATION

- A. TYPE P-1: ASTM C547, 1” preformed rigid fiberglass pipe insulation. Thermal Conductivity: 0.23 at 75 degrees F. Operating Temperature Range: 0 to 850 degrees F. Vapor Barrier Jacket: ASTM C1136, Type I, factory applied reinforced foil kraft with self-sealing adhesive joints. Jacket Temperature Limit: minus 20 to 150 degrees F. Johns-Manville “Micro-Lok” or approved equal.

2.2 PIPE INSULATION JACKETS

- A. ASTM B209 exterior grade aluminum, 0.016 inch thick sheet, embossed finish roll stock for straight pipe. Pre-formed aluminum covers for elbows and tees. Provide wing seal band closures.

2.3 CHARGE AIR TUBING INSULATION

- A. Pad Tape – Woven fiberglass tape, minimum 1000F service, 1/8” thick, 3” wide. Integrated Marketing Group 180 or approved equal.
- B. Clamps - Stainless steel T-bolt clamps, Ideal-Tridon 30051 or approved equal.

2.4 HEAT EXCHANGER INSULATION

- A. ASTM C612, 1” preformed rigid fiberglass board type insulation with FSK foil facing one side. Johns-Manville Spin Glas or approved equal.

PART 3 - EXECUTION

3.1 EXAMINATION

- A. Check materials for damage that may have occurred during shipment. Repair damaged materials as required or replace with new materials.
- B. Verify piping has been tested before applying insulation materials.
- C. Verify surfaces are clean and dry, with foreign material removed.
- D. Verify piping has been painted up to areas to be insulated.

3.2 INSTALLATION – HYDRONIC PIPE

- A. Install pipe insulation in accordance with manufacturer's installation instructions.
- B. Install insulation where indicated on Drawings.
- C. Cover all piping insulation with continuous aluminum jackets. Provide longitudinal slip joints with minimum 2 inch laps. Overlap circumferential joints 2" minimum. Secure with wing seal bands at each circumferential joint and between joints at 12" on center maximum.

3.3 INSTALLATION – CHARGE AIR TUBING

- A. Install insulation where indicated on Drawings.
- B. Spiral wrap yarn tape with 50% overlap continuous over sections of tubing indicated to be insulated.
- C. Secure ends of yarn tape with hose clamps.

3.4 INSTALLATION - HEAT EXCHANGER INSULATION

- A. Cover all faces of heat exchanger with 1" preformed rigid fiberglass board type insulation. Cut insulation to fit tight all around.
- B. Seal all edges, joints, and corners with reinforced foil tape.

3.5 MODULE FIELD INSTALLATION – HYDRONIC AND EXHAUST PIPE

- A. As part of the on site field work complete installation of all insulation including loose ship items furnished with module. Reinstall sections of insulation that were shop cut and fit as part of the module assembly contract.

END OF SECTION

SECTION 23 09 00
INSTRUMENTATION AND CONTROL DEVICES

PART 1 GENERAL

1.1 SUMMARY

- A. Section includes:
 - 1. Instrumentation Equipment
 - 2. Pressure gauges.
 - 3. Thermometers and Thermowells.

1.2 RELATED REQUIREMENTS

- A. Section 23 05 00 – Common Work Requirements for Mechanical.
- B. Section 23 21 16 - Hydronic Equipment and Specialties.
- C. Division 26 - Electrical

1.3 REFERENCES

- A. American Society of Mechanical Engineers:
 - 1. ASME B40.1 - Gauges - Pressure Indicating Dial Type - Elastic Element.
- B. ASTM International:
 - 1. ASTM E1 - Standard Specification for ASTM Thermometers.
 - 2. ASTM E77 - Standard Test Method for Inspection and Verification of Thermometers.

1.4 SUBMITTALS

- A. Provide submittals for all products and systems under this Section in accordance with Section 23 05 00 - Common Work Results for Mechanical and Division 1.
- B. Product Data:
 - 1. Submit manufacturers catalog literature for all instrumentation items specified herein.
 - 2. Submit manufacturers catalog literature for each item indicated on the Instrumentation Equipment Schedule on Sheet M1.1.

1.5 QUALIFICATIONS

- A. Manufacturer: Company specializing in manufacturing products specified in this section.
- B. Installer: Company specializing in performing Work of this section.

1.6 DELIVERY, STORAGE, AND HANDLING

- A. Accept controls on site in original factory packaging. Inspect for damage.

1.7 COORDINATION

- A. Coordinate installation of control components with work of Division 26.

PART 2 PRODUCTS

2.1 PRESSURE GAUGES

- A. Dry type stainless steel case, tube, and socket, 1/4" NPT bottom connection, 2-1/2" dial size. Range as indicated on Drawings.
- B. Range 0-100 psi: Trerice Model 700SS-25-02-L-A-110 or approved equal.

2.2 THERMOMETERS

- A. Digital thermometer, solar powered, LCD display, -50 to +300 F range or dual F/C range, 1% of reading accuracy, variable angle display, 3-1/2" stem length.
- B. Weiss DVU35 or approved equal.
- C. Provide all thermometers with a 3/4" NPT brass thermowell.

PART 3 EXECUTION

3.1 EXAMINATION

- A. Check equipment for damage that may have occurred during shipment. Repair damaged equipment as required or replace with new equipment.
- B. Verify systems to be controlled are ready to operate.

3.2 INSTALLATION

- A. Install instrumentation where indicated on the Drawings in accordance with details and manufacturer's installation instructions.
- B. Install gauges and thermometers in locations where they are clear of valve handles or other obstructions and where they can be easily read from normal operating level. Install with face within 45 degrees of vertical.
- C. Adjust gauges and thermometers to final angle, and clean faces.
- D. Isolate hydronic pressure gauges during pressure testing.
- E. Install conduit and electrical wiring in accordance with Division 26.

3.3 TESTING AND CALIBRATION – TEMPERATURE DEVICES

- A. All thermometers shall be calibrated within +/- 1°F of actual temperature using boiling water. Calibrate digital thermometers using the internal control potentiometer.
- B. Set heat recovery pumps to speeds or control modes as indicated on the Drawings. With heat recovery system circulating, read flow rate from flow meter and compare to design value. Cycle pump on and off and change speed to confirm proper operation.

END OF SECTION

SECTION 23 11 13
POWER PLANT FUEL-OIL PIPING

PART 1 - GENERAL

1.1 SUMMARY

- A. Scope: This section applies to all diesel fuel and lube oil piping systems installed above grade at the power plant including interior and exterior piping.
- B. Section includes:
 - 1. Fuel oil piping.
 - 2. Lube oil (used oil) piping.
 - 3. Fittings, Valves, and Strainers.

1.2 RELATED REQUIREMENTS

- A. Section 23 05 00 – Common Work Requirements for Mechanical.
- B. Section 23 05 29 - Hangers and Supports for Piping and Equipment.
- C. Section 23 12 13 – Power Plant Fuel-Oil Equipment and Specialties.

1.3 PERFORMANCE REQUIREMENTS

- A. Minimum Working-Pressure Rating: Unless otherwise indicated, minimum pressure requirement for fuel and lube oil piping is 150 psig.

1.4 REFERENCES

- A. American Society of Mechanical Engineers:
 - 1. ASME B31.1 - Power Piping.
 - 2. ASME B31.9 - Building Services Piping.
 - 3. ASME B16.5 Flanges and Flanged Fittings
 - 4. ASME B16.9 Factory-Made Wrought Steel Butt welding Fittings
 - 5. ASME B16.11 Forged Fittings, Socket-Welding and Threaded
 - 6. ASME Section IX - Boiler and Pressure Vessel Code - Welding and Brazing Qualifications.
- B. ASTM International:
 - 1. ASTM A106B – Standard Specification for Seamless Carbon Steel Pipe for High Temperature Services.
 - 2. ASME B16.11 Forged Fittings, Socket-Welding and Threaded

1.5 SYSTEM DESCRIPTION

- A. Provide piping of material as specified in PART 2.

- B. Provide flanges, unions, or couplings at locations requiring servicing. Use unions, flanges, or couplings downstream of valves and at equipment connections. Do not use direct welded connections to valves, equipment.
- C. Provide pipe hangers and supports per Drawings and specifications.

1.6 SUBMITTALS

- A. Provide submittals for all products and systems under this Section in accordance with Section 23 05 00 - Common Work Results for Mechanical and Division 1.
- B. Product Data: Provide submittals for all products and systems described herein.
- C. Welder's Certificate: Provide welder's certificate in accordance with Section 23 05 00 – Common Work Requirements for Mechanical.

1.7 QUALITY ASSURANCE

- A. Division 1 – Quality Control.
- B. Perform Work in accordance with ASME B31.9 code for installation of piping systems and ASME Section IX for welding materials and procedures.
- C. Perform pipe welding with experienced welder with current API or equivalent certification for pipe welding in all positions.

1.8 QUALIFICATIONS

- A. Manufacturer: Company specializing in manufacturing products specified in this section.
- B. Installer: Company specializing in performing Work of this section with current certification.

1.9 DELIVERY, STORAGE, AND HANDLING

- A. Accept valves on site in shipping containers with labeling in place. Inspect for damage.
- B. Provide temporary end caps and closures on piping and leave in place until installation.

1.10 FIELD MEASUREMENTS

- A. Verify field measurements prior to fabrication.

PART 2 - PRODUCTS

2.1 GENERAL

- A. Materials shall be new unless otherwise specified. All items of the same type shall be of the same manufacturer.
- B. Oil pipe shall have welded joints except for threaded connections to equipment and valves as required and shown. Provide flanged joints where indicated on Drawings to allow removal of individual components.

- C. Provide butt weld joints for all pipe 2 inches in diameter and larger and on smaller pipe where specifically indicated on Drawings. Provide socket weld or threaded joints for all piping smaller than 2 inches in diameter unless indicated otherwise.
- D. Vent piping shall be galvanized pipe with threaded joints.

2.2 PIPE

- A. Oil Pipe (DFS, DFR, UOR): ASTM A106B seamless black steel pipe, Schedule 80.
- B. Vent Pipe: ASTM A53B ERW welded galvanized steel pipe, Schedule 40.

2.3 PIPE FITTINGS

- A. Fittings: ASTM A234 seamless carbon steel butt weld fittings for all pipe 2 inches in diameter and larger and on smaller pipe where specifically indicated on Drawings. Provide socket weld or threaded joints for all piping smaller than 2 inches in diameter using ASTM 105, forged steel fittings, minimum 3000 lb.
- B. Flanges: ASTM A105 forged steel, ANSI 150# raised face unless indicated otherwise. Butt or socket weld as indicated.
- C. Flange Gaskets: Spiral wound metallic gaskets, Flexitallic CG or approved equal.
- D. Flange Bolts: On all exterior piping provide galvanized bolts, nuts, and washers. On interior piping provide zinc plated or galvanized bolts, nuts, and washers.
- E. Vent pipe shall have threaded joints with minimum 300# galvanized threaded fittings.

2.4 BALL VALVES

- A. Flanged Ball Valves: Carbon steel body, unibody style with reduced port, ANSI 150# raised face flanged ends, stainless steel ball and trim, PTFE seat and seals for NACE MR0175 service, 150 psig minimum working pressure, with lockable handle. Keckley Style BVF1 or approved equal. Note that for a substitute valve to be approved it must be a domestic manufactured high quality industrial valve such as Apollo or Nibco.

PART 3 - EXECUTION

3.1 EXAMINATION

- A. Check materials for damage that may have occurred during shipment. Repair damaged materials as required or replace with new materials.

3.2 PREPARATION

- A. Ream threaded pipe ends and remove burrs. Remove scale and dirt, on inside and outside, before assembly.
- B. Thoroughly coat male pipe ends with Teflon tape and Teflon pipe joint compound prior to assembling.
- C. Coat flange gaskets and bolts with anti-seize compound prior to assembling joints.

3.3 INSTALLATION - PIPING

- A. Route piping in orderly manner and maintain gradient.
- B. Install pipe hangers and supports in accordance with Drawings and Section 23 05 29.
- C. Install piping to conserve building space and not interfere with use of space. Group piping whenever practical at common elevations.
- D. Install piping to allow for expansion and contraction without stressing pipe, joints, or connected equipment.
- E. Install valves with stems upright or horizontal, not inverted. Provide access where valves are not exposed.
- F. Protect piping systems from entry of foreign materials by temporary covers, completing sections of the work, and isolating parts of completed system.
- G. Seal wall penetrations as indicated on the Drawings.
- H. Prepare and paint pipe, fittings, supports, and accessories not pre-finished in accordance with Section 23 05 00.
- I. Install identification on piping systems in accordance with Section 23 05 00.

3.4 FUEL AND LUBE OIL PIPING TESTING AND REPORTING

- A. Division 1 – Quality Control
- B. Provide notification and reporting in accordance with Section 23 05 00 – Common Work Requirements for Mechanical.
- C. Test all oil piping with minimum 125 psig air. Test 100% of welds visually for leaks with each joint soaked in a foaming soapy water solution, and visually inspect each joint for leaks. Isolate and pressure test each run of piping for a minimum of one hour. Provide blind flanges, threaded caps or plugs at each end of the test section as needed. Do not conceal pipe joints before pressure testing is complete. Isolate equipment and components rated for lesser pressures so as not to damage these items.
- D. Pressure test piping system again after all equipment is installed at 50 psi for a minimum of one hour, or the maximum rated pressure of the weakest component, whichever is less.

3.5 SYSTEM STARTUP

- A. Prime equipment and piping prior to testing and verify operation as indicated in Section 23 12 13.

END OF SECTION

SECTION 23 12 13

POWER PLANT FUEL-OIL EQUIPMENT AND SPECIALTIES

PART 1 – GENERAL

1.1 SUMMARY

- A. Scope: This section applies to all fuel and lube oil piping systems.
- B. Section includes Fuel and Lube Oil System Equipment.

1.2 RELATED REQUIREMENTS

- A. Section 23 05 00 – Common Work Requirements for Mechanical.
- B. Section 23 05 29 - Hangers and Supports for Piping and Equipment.
- C. Section 23 11 13 – Power Plant Fuel-Oil Piping.
- D. Division 26 – Electrical.

1.3 SUBMITTALS

- A. Provide submittals for all products and systems under this Section in accordance with Section 23 05 00 - Common Work Results for Mechanical and Division 1.
- B. Product Data:
 - 1. Submit manufacturers catalog literature for all items specified herein.
 - 2. Submit manufacturers catalog literature for each item indicated on the Fuel System Equipment Schedule on Sheet M1.1.

1.4 CLOSEOUT

- A. Division 1 - Closeout Requirements.
- B. Operation and Maintenance Data: Submit instructions for calibrating instruments, installation instructions, assembly views, servicing requirements, lubrication instruction, and replacement parts list.

PART 2 – PRODUCTS

2.1 DIESEL FUEL SYSTEM EQUIPMENT

- A. Provide equipment, and appurtenances as indicated in the Fuel System Equipment Schedule on Sheet M1.1.
- B. Filter: Provide spare filter elements, type and quantity as indicated in the Fuel System Equipment Schedule on Sheet M1.1.

2.4 VENT CAP

- A. Vent: Aluminum body, stainless steel screen, FPT connection, size as indicated. Morrison Figure 155 or approved equal.

PART 3 – EXECUTION

3.1 EXAMINATION

- A. Check equipment for damage that may have occurred during shipment. Repair damaged equipment as required or replace with new equipment.

3.2 PREPARATION

- A. Protect bright finished shafts, bearing housings, and similar items until in service. No rust will be permitted.

3.3 INSTALLATION

- A. Install equipment in accordance with Drawings and manufacturer's installation instructions.
- B. Electrical installation shall be in accordance with Division 26 Specifications.

3.5 SYSTEM STARTUP

- A. Prior to starting fuel and oil pumps remove suction hoses from inlet connections, prime pump cavities with lube oil, then energize momentarily to verify proper rotation.
- B. Manually open actuated ball valve and use hand pump to prime piping into day tank. Prime all piping and fill all filters with diesel fuel then bleed off air prior to starting pumps.
- C. Verify operation of all day tank and blender controls including timers and level alarms.
- D. Verify operation the day tank meter including pulser during initial fill of the day tank.

END OF SECTION

SECTION 23 21 13
HYDRONIC PIPING

Notes:

- 1) *All paragraphs below shown in light italic text reference work that was performed as part of the prior module assembly contract and are included here for reference only.*
- 2) *All paragraphs below shown in standard text are to be performed under this contract.*

PART 1 - GENERAL

1.1 SUMMARY

- A. Scope: This section applies to all hydronic (glycol) piping systems.
- B. Section includes:
 1. Coolant (engine cooling) piping.
 2. Interior heat recovery piping.
 3. Pipe fittings.
 4. Valves and strainers.
 5. Engine coolant (ethylene glycol).
 6. Heat recovery fluid (propylene glycol).

1.2 RELATED REQUIREMENTS

- A. Section 23 05 00 - Common Work Requirements for Mechanical.
- B. Section 23 05 29 - Hangers and Supports for Piping and Equipment.
- C. Section 23 07 19 - Piping Insulation
- D. Section 23 21 16 - Hydronic Equipment and Specialties.
- E. Section 33 61 14 - PEX Arctic Pipe.
- F. Section 33 61 24 - Steel Arctic Pipe.
- G. Section 33 61 25 – Exterior Insulated Steel Pipe.

1.3 REFERENCES

- A. American Society of Mechanical Engineers:
 1. ASME B16.3 - Malleable Iron Threaded Fittings.
 2. ASME B16.4 - Gray Iron Threaded Fittings.
 3. ASME B16.18 - Cast Copper Alloy Solder Joint Pressure Fittings.
 4. ASME B31.1 - Power Piping.
 5. ASME B31.9 - Building Services Piping.

6. ASME Section IX - Boiler and Pressure Vessel Code - Welding and Brazing Qualifications.
- B. ASTM International:
 1. ASTM A53B - Standard Specification for Pipe, Steel, Black and Hot-Dipped.
 2. ASTM B88 - Standard Specification for Seamless Copper Water Tube.
- C. American Welding Society:
 1. AWS A5.8 - Specification for Filler Metals for Brazing and Braze Welding.
 2. AWS D1.1 - Structural Welding Code - Steel.
- D. Manufacturers Standardization Society of the Valve and Fittings Industry:
 1. MSS SP 58 - Pipe Hangers and Supports - Materials, Design and Manufacturer.
 2. MSS SP 69 - Pipe Hangers and Supports - Selection and Application.

1.4 SYSTEM DESCRIPTION

- A. Provide piping system types as indicated on the Drawings.
- B. Where copper tubing connects to steel piping provide connections as detailed on Drawings using bronze or brass fittings or valves for transition.
- C. Provide flanges, unions, and couplings at locations requiring servicing. Install unions, flanges, and couplings downstream of valves and at equipment connections.
- D. Provide pipe hangers and supports in accordance with Drawings and specifications.
- E. Use ball valves or butterfly valves for shut-off and to isolate equipment where indicated.
- F. Use gauge cock isolation valves to isolate instrumentation and small devices where indicated.
- G. Use hose end drain valves with cap for drains and air purge vents where indicated.
- H. Flexible Connections: Use flexible connectors and hoses where indicated.

1.5 SUBMITTALS

- A. Provide submittals for all products and systems under this Section in accordance with Section 23 05 00 - Common Work Results for Mechanical and Division 1.
- B. Product Data:
 1. Piping: Submit data on pipe materials, fittings, and accessories.
 2. Valves: Submit manufacturers catalog information with valve data and ratings for each service.
 3. Glycol: Submit manufacturers catalog information for propylene glycol solution for heat recovery service.
- C. Welder's Certificate: Provide welder's certificate in accordance with Section 23 05 00 – Common Work Requirements for Mechanical.

1.6 QUALITY ASSURANCE

- A. Division 1 – Quality Control
- B. Perform Work in accordance with ASME B31.1 and ASME B31.9 code for installation of piping systems.
- C. Perform pipe welding with experienced welder with current API or equivalent certification for pipe welding in all positions.

1.7 QUALIFICATIONS

- A. Manufacturer: Company specializing in manufacturing products specified in this section.
- B. Fabricator or Installer: Company specializing in performing Work of this section with current certification.

1.8 DELIVERY, STORAGE, AND HANDLING

- A. Accept valves on site in shipping containers with labeling in place. Inspect for damage.
- B. Provide temporary end caps and closures on piping and leave in place until installation.
- C. Store glycol solution in sealed containers clearly marked by product type.

1.9 FIELD MEASUREMENTS

- A. Verify field measurements prior to fabrication.

PART 2 - PRODUCTS

2.1 COOLANT PIPING

- A. *Steel Piping: Provide schedule 40 ASTM A106B, seamless black steel pipe with butt weld joints for engine cooling piping as specifically indicated on the Drawings.*
 - 1. *Fittings: ASTM A234 seamless carbon steel butt weld fittings for all pipe 2 inches in diameter and larger and on smaller pipe where specifically indicated on Drawings. Provide ASTM 105, forged steel fittings, minimum 3000 lb. socket weld or threaded fittings for pipe smaller than 2 inches and for connections as indicated.*
 - 2. *Flanges: ASTM A105 forged steel, ANSI 150# flat face unless indicated otherwise. Butt or socket weld as indicated.*
 - 3. *Flange Gaskets: Spiral wound metallic gaskets, Flexitallic CG or approved equal.*
 - 4. *Flange Bolts: On all exterior piping provide galvanized bolts, nuts, and washers. On interior piping provide zinc plated or galvanized bolts, nuts, and washers.*
 - 5. *Unions: ASTM A105 forged steel threaded unions, Class 3000 minimum.*
- B. *Copper Piping: Provide ASTM B88, Type L drawn copper tubing with solder or threaded joints for engine cooling piping as specifically indicated on the Drawings.*
 - 1. *Fittings: ASME B16.22 solder wrought copper.*
 - 2. *Joints: soldered with 95-5 tin-antimony solder or silver solder except on tee drill connections use copper brazing rod.*

3. *Flanges: Provide ANSI 150# companion flanges for transition to steel piping or flanged valves and equipment. Flanges to be two-piece with powder coated steel flange and solder copper tube adapter, Nibco 672 or approved equal.*
4. *Flange Gaskets: Spiral wound metallic gaskets, Flexitallic or approved equal.*
5. *Flange Bolts: On all exterior piping provide galvanized bolts, nuts, and washers. Bolts, nuts, and washers on interior piping may be zinc plated.*
6. *Unions: Bronze unions with solder ends except where specifically indicated as threaded.*

2.2 HEAT RECOVERY PIPING

- A. Provide ASTM B88, Type L drawn copper tubing with solder or threaded joints.
 1. Fittings: ASME B16.22 solder wrought copper.
 2. Joints: soldered with 95-5 tin-antimony solder or silver solder except on tee drill connections use copper brazing rod.
 3. Flanges: Provide ANSI 150# companion flanges for transition to steel piping or flanged valves and equipment. Flanges to be two-piece with powder coated steel flange and solder copper tube adapter, Nibco 672 or approved equal.
 4. Flange Gaskets: Spiral wound metallic gaskets, Flexitallic or approved equal.
 5. Flange Bolts: On all exterior piping provide galvanized bolts, nuts, and washers. Bolts, nuts, and washers on interior piping may be zinc plated.
 6. Unions: Bronze unions with solder ends except where specifically indicated as threaded.

2.3 BUTTERFLY VALVES

- A. Lug style ductile or cast iron body, ANSI 150# flange pattern ends, stainless steel stem with bronze bushing, bronze or nylon coated ductile iron disc, EPDM seats, locking handle. Milwaukee ML-233E, Bray Series 31, or approved equal.

2.4 BALL VALVES

- A. Threaded or soldered end as indicated and required, bronze body, chrome plated bronze or brass ball, full port, TFE or Viton packing and seat ring, minimum 200 psig WOG rating. Domestic only. Apollo, Hammond, Milwaukee, Nibco, or approved equal.

2.5 CHECK VALVES

- A. Threaded or soldered end as indicated and required, bronze body, swing check style, minimum 200 psig WOG rating. Domestic only. Hammond, Milwaukee, Nibco, or approved equal.

2.6 DRAIN VALVES

- A. Bronze body, 1/2" or 3/4" size and solder cup or MPT connection to match associated pipe connection, 3/4" male hose end with cap and jack chain. FNW 426D, 426F, 427D, or 427F or approved equal.

2.7 STRAINERS

- A. Type Y pattern, carbon steel body, ANSI 150# flanged ends, size as indicated on Drawings, gasketed bolt-on cover, 1/16" stainless steel screen, 150 psig minimum working pressure. Keckley Style SA7 or approved equal.

2.8 ENGINE COOLANT (ETHYLENE GLYCOL)

(Note: Glycol under this paragraph, including spare, was furnished as part of the module assembly contract and is included here for reference.)

- A. *Glycol Solution for Engine Cooling Service: The glycol shall be extended life (heavy duty) ethylene glycol, Shell Rotella ELC, Chevron Delo ELC, or approved equal. Note that standard life coolant will not be accepted.*
- B. *The solution shall be premixed to a ratio of 50% ethylene glycol to 50% water. The water shall be treated in accordance with glycol manufacturer's recommendations. The mixed solution shall be **dyed bright pink or light red**, no exceptions.*
- C. *The solution shall be packaged in sealed 55 gallon drums and labeled "Ethylene Glycol" with red lettering.*
- D. *Furnish a minimum of 4 each 55 gallon drums of ethylene glycol solution.*

2.9 HEAT RECOVERY FLUID (PROPYLENE GLYCOL)

- A. Glycol Solution for Heat Recovery Service: The glycol shall be extended life (heavy duty) propylene glycol, Safe-T-Therm HD, Dowfrost HD, or approved equal. Note that standard life propylene glycol will not be accepted.
- B. The solution shall be premixed to a ratio of 50% propylene glycol to 50% water. The water shall be treated in accordance with glycol manufacturer's recommendations. The mixed solution shall be **dyed bright yellow**, no exceptions.
- C. The solution shall be packaged in sealed 55-gallon drums and labeled "Propylene Glycol" with yellow lettering.
- D. Furnish a minimum of 14 each 55 gallon drums of propylene glycol solution.

PART 3 - EXECUTION

3.1 EXAMINATION

- A. Check materials for damage that may have occurred during shipment. Repair damaged materials as required or replace with new materials.

3.2 PREPARATION

- A. Ream pipe ends and remove burrs. Remove scale and dirt, on inside and outside, before assembly.
- B. Keep open ends of pipe free from scale and dirt. Protect open ends with temporary plugs or caps.
- C. On copper tube and solder fittings mechanically clean to bright metal and flux prior to assembling.

D. On threaded pipe and fittings thoroughly coat male threads with Teflon tape and Teflon based pipe joint compound prior to assembling.

E. Coat flange gaskets and bolts with anti-seize compound prior to assembling joints.

3.3 INSTALLATION

A. Route piping in orderly manner and slope to drain at low points and vent at high points.

B. Install piping to conserve building space and not interfere with use of space. Group piping whenever practical at common elevations.

C. Install piping to allow for expansion and contraction without stressing pipe, joints, or connected equipment.

D. Install valves with stems upright or horizontal, not inverted. Provide access where valves are not exposed.

E. Protect piping systems from entry of foreign materials by temporary covers, completing sections of the work, and isolating parts of completed system.

F. Install pipe hangers and supports in accordance with Section 23 05 29. Touch up all galvanized items in accordance with Section 23 05 00.

G. Prepare and finish paint cabinet unit heat support shrouds and supports as indicated on the Drawings.

H. Seal wall and floor penetrations as indicated on the Drawings.

I. Insulate piping in accordance with Section Division 33 sections for the specific piping system.

J. Install valve tags in accordance with Section 23 05 00.

K. Install flow arrows on piping exposed within interior spaces in accordance with Section 23 05 00. Note that exterior piping and piping concealed within cabinet unit heater shrouds does not require flow arrows.

3.4 HYDRONIC PIPING TESTING AND REPORTING - GENERAL

A. Division 1 – Quality Control

B. Provide notification and reporting in accordance with Section 23 05 00 – Common Work Requirements for Mechanical.

3.5 COOLANT PIPING SHOP TESTING

A. Isolate engines, radiators, and pressure gauges prior to pressure testing.

B. Hydrostatically test all piping at 100 psig minimum for one hour with no noticeable water leaks or pressure drops except as caused by temperature change.

3.6 COOLANT SYSTEM SHOP FLUSHING

A. Provide temporary plate type strainers, Hellan TP, Hendrix TF, or equal. Install a strainer on the inlet to each radiator and install a strainer at flanged joint where return piping from radiators enters the plant.

- B. Fill the entire system with potable water and flush. Run all engines long enough with adequate load to get thermostats open and to circulate water through all piping and accessories. To ensure engines are not damaged, do not run under high load or for extended periods of time with potable water.*
- C. Drain system completely. Remove temporary strainers and clean out all debris from inside pipe in vicinity of strainer.*

3.7 COOLING SYSTEM SHOP FILLING AND CHARGING

- A. After pressure testing and flushing, fill entire system with ethylene glycol solution. Perform all functional testing of the module required by the Contract Documents. Ensure that engines are operated long enough with adequate load to get thermostats fully open and to circulate glycol through all piping and accessories.*
- B. Operate control room heating system to ensure it is fully charged with glycol.*
- C. After the system is up to normal operating temperature verify the glycol level in expansion tank is between 1/2 and 2/3 and the pressure at the hand glycol fill pump is between 8 and 10 PSIG.*
- D. Verify proper function of all instrumentation and calibrate all devices.*
- E. All excess glycol solution shall be left with the modules in the original drums and sealed for shipping with the module*

3.8 COOLING SYSTEM ON SITE FILLING AND TESTING

- A.** Upon completion of on-site radiator piping installation, add Owner furnished ethylene glycol solution to the cooling system as required to top off and bring the level in the expansion tank to approximately 50%.
- B.** Isolate engines and radiators prior to pressure testing and hydrostatically test coolant piping mains at 100 psig minimum for one hour with no noticeable water leaks or pressure drops except as caused by temperature change.
- C.** After pressure testing, perform all functional testing of the module required by the Contract Documents. Ensure that engines are operated long enough with adequate load to get thermostats fully open and to circulate glycol through all piping and accessories.
- D.** Operate control room heating system to ensure it is fully charged with glycol.
- E.** After the system is up to normal operating temperature verify the glycol level in expansion tank is between 1/2 and 2/3 and the pressure at the hand glycol fill pump is between 8 and 10 PSIG.
- F.** Verify proper function of all instrumentation and calibrate all devices.
- G.** Transfer excess ethylene glycol solution into glycol storage tank until 95% full. Store any excess ethylene glycol solution with the module in the original drums sealed for long-term storage.

3.9 HEAT RECOVERY SYSTEM SHOP TESTING AND FLUSHING

- A. Install temporary pipe or hose jumper between heat recovery pipe terminations.*

- B. Hydrostatically test all piping at 100 psig minimum for one hour with no noticeable water leaks or pressure drops except as caused by temperature change.*
- C. Fill the entire system with potable water and flush thoroughly. Run pumps as required to obtain circulation through the entire system.*
- D. Operate heat recovery system with engines under load and engine cooling system up to normal temperature. Verify proper function of all instrumentation and calibrate all devices.*
- E. Upon completion of testing allow system to cool down to ambient temperature. Drain system completely. Blow out with air as required to ensure freeze protection.*

3.10 HEAT RECOVERY INTERIOR PIPING TESTING

- A. This applies to all interior heat recovery piping in the end user buildings. Separately test exterior piping as indicated in paragraph that follows.
- B. Isolate cabinet unit heaters and arctic pipe prior to pressure testing interior piping.
- C. Pressurize with minimum 50 psig air, soak each joint with a foaming soapy water solution, and visually inspect each joint for leaks.

3.11 HEAT RECOVERY EXTERIOR PIPING TESTING

- A. This applies to all exterior heat recovery arctic piping and above grade insulated steel piping mains.
- B. Upon completion of arctic pipe installation and prior to insulating and covering joints, pressure test all PEX crimp joints and steel weld joints. Pressurize arctic pipe with minimum 30 psig air, soak each joint with a foaming soapy water solution, and visually inspect each joint for leaks.

3.12 HEAT RECOVERY SYSTEM FILLING, FLUSHING, AND PURGING

- A. After pressure testing all piping, bleed air reservoir on the expansion tank in the module as required to maintain 10 PSIG residual with the system empty.
- B. At end user buildings, close isolation valves at each unit heater and cabinet unit heater to ensure no flow through the heater coils prior to filling system. Verify that the cabinet unit heater hoses are not connected to heaters.
- C. Fill the entire heat recovery piping system with propylene glycol solution to 20 PSIG minimum with system cold. Vent air from all high point vents prior to starting circulating pumps. Note that high point bleeds are located in the module and in buildings B and G.
- D. Cycle main heat recovery loop circ pump P-HR1B on and off and vent high points until all air has been purged from the main piping loop. Use hoses and buckets to purge and capture salvaged glycol.
- E. Add propylene glycol solution as required to maintain 20 PSIG minimum with system cold. With diesel generator(s) running, start the heat recovery system primary and secondary circulation pumps P-HR1A and P-HR1B. Bring the entire heat recovery system up to normal temperature (170°F minimum) and add propylene glycol solution as required to bring system pressure to 30 PSIG minimum at expansion tank.

- F. Circulate hot glycol for 24 hours minimum then shut pumps off. Isolate and clean piping strainers which are located in the module and in building B. After cleaning strainers open strainer isolation valves.
- G. In buildings B and G use hoses and buckets to purge air and debris from high point bleeds then open branch piping valves to unit heaters. Set the pumps to the specified speed, open the isolation valves, and turn up the thermostat to start the associated circ pump. Cycle unit heater pumps on and off and vent bleed fitting until all air has been purged and capture salvaged glycol.
- H. Go to each cabinet unit heater in the system. Place the cabinet unit heater hoses in a bucket and crack valves to purge air and debris. Bleed a minimum of 1 gallon from each hose to ensure branch piping is completely flushed and capture salvaged glycol. Raise hose ends and crack valves to fill hoses with fluid then make final connection to the cabinet unit heaters. Using thermostat control, cycle cabinet unit heater pumps on and off and vent bleed fittings on top of cabinet unit heaters.
- I. When the entire system comes up to normal temperature (170°F minimum) add propylene glycol solution as required to bring system pressure to 30 PSIG minimum at expansion tank.
- J. Verify proper function of all instrumentation and calibrate all devices. Verify power plant heat recovery readings on switchgear SCADA system.
- K. Go through the entire system including all end user buildings and check for leaks. Perform functional test of each unit heater and cabinet unit heater thermostatic controls, verifying that fan and pump cycle on and off together.
- L. Add propylene glycol solution as required to bring system pressure to 30 PSIG minimum at expansion tank. Filter salvaged glycol with 30 micron filter and place back in drums. Store all excess propylene glycol solution in the original drums sealed for long-term storage. Verify that drums are clearly labeled "PROPYLENE GLYCOL" with yellow lettering.

END OF SECTION

SECTION 23 21 16
HYDRONIC EQUIPMENT AND SPECIALTIES

PART 1 – GENERAL

1.1 SUMMARY

- A. Scope: This section applies to all hydronic (glycol) piping systems.
- B. Section includes:
 - 1. Heating Recovery Equipment.
 - 2. Hoses.

1.2 RELATED REQUIREMENTS

- A. Section 23 05 00 – Common Work Requirements for Mechanical.
- B. Section 23 05 29 - Hangers and Supports for Piping and Equipment.
- C. Section 23 21 13 - Hydronic Piping.
- D. Division 26 - Electrical.

1.3 SUBMITTALS

- A. Provide submittals for all products and systems under this Section in accordance with Section 23 05 00 - Common Work Results for Mechanical and Division 1.
- B. Product Data:
 - 1. Submit manufacturers catalog literature including manufacturer's installation instructions for each item indicated on the End User Building Heat Recovery Equipment Schedule on Sheet M8.1.
 - 2. Submit manufacturer's catalog information for appurtenances, hoses, hose fittings, and all other items specified herein.
- C. Shop Drawings: Submit shop drawings for fabricated shrouds. Note that if shrouds will be fabricated exactly as indicated on the Drawings, the design Drawings can be submitted in lieu of shop drawings.

1.4 QUALIFICATIONS

- A. Manufacturer: Company specializing in manufacturing products specified in this section.
- B. Installer: Company specializing in performing Work of this section.

1.5 DELIVERY, STORAGE, AND HANDLING

- A. Accept material on site in shipping containers with labeling in place. Inspect for damage.
- B. Protect systems from entry of foreign materials by temporary covers, caps and closures, completing sections of the work, and isolating parts of completed system until installation.

1.6 FIELD MEASUREMENTS

- A. Verify field measurements before fabrication.

PART 2 - PRODUCTS

2.1 HEAT RECOVERY & PLANT HEATING SYSTEM EQUIPMENT

- A. Provide all equipment and accessories as indicated in the End User Building Heat Recovery Equipment Schedule on Sheet M8.1.

2.2 HOSES

- A. Glycol Hoses: Teflon hose with stainless steel outer braid, Eaton Weatherhead H243 or approved equal. Provide with re-useable plated steel straight JIC swivel ends with NPT adapters.

2.3 FABRICATIONS

- A. Shrouds: Provide fabricated shrouds as indicated on Drawings.

PART 3 - EXECUTION

3.1 EXAMINATION

- A. Check equipment for damage that may have occurred during shipment. Repair damaged equipment as required or replace with new equipment.

3.2 PREPARATION

- A. Protect bright finished shafts, bearing housings, and similar items until in service. No rust will be permitted.

3.3 INSTALLATION

- A. Install equipment and accessories in strict compliance with manufacturer's instructions.
- B. Install piping system and appurtenances as indicated on Drawings.

3.4 SYSTEM STARTUP

- A. Clean and flush glycol piping systems before adding glycol solution. See Section 23 21 13 - Hydronic Piping.
- B. Upon initial fill of tanks, calibrate manual level gauges and level sensing probes. See Section 23 09 00 - Instrumentation.
- C. Once systems are in operation and up to normal operating temperatures, calibrate thermometers and temperature sensors. See Section 23 09 00 - Instrumentation.

END OF SECTION

SECTION 23 31 13
METAL DUCTS AND VENTILATION EQUIPMENT

Notes:

- 1) *All ventilation system fabrications were furnished and some items were installed as part of the prior module assembly contract. Work that was performed as part of the prior module assembly contract shown below in light italic text and included here for reference only.*
- 2) *Installation of exterior exhaust hoods and the intake duct system is to be performed under this contract and is shown below in standard text.*

PART 1 - GENERAL

1.1 SUMMARY

A. Section includes:

1. *Duct Materials.*
2. *Fans.*
3. *Dampers.*
4. *Actuators.*
5. *Filters.*

1.2 RELATED REQUIREMENTS

- A. Section 23 05 00 – Common Work Requirements for Mechanical.*
- B. Section 23 05 29 - Hangers and Supports for Piping and Equipment.*
- C. Division 26 – Electrical.*

1.3 REFERENCES

A. ASTM International:

1. *ASTM A653 - Standard Specification for Steel Sheet, Zinc-Coated (Galvanized) or Zinc-Iron Alloy-Coated (Galvannealed) by the Hot-Dip Process.*
2. *ASTM B209 - Standard Specification for Aluminum and Aluminum-Alloy Sheet and Plate.*

B. Air Movement and Control Association International, Inc.: AMCA 500 - Test Methods for Louvers, Dampers, and Shutters.

C. National Fire Protection Association: NFPA 90A - Standard for the Installation of Air Conditioning and Ventilating Systems.

D. Sheet Metal and Air Conditioning Contractors: SMACNA - HVAC Duct Construction Standard - Metal and Flexible.

1.4 PERFORMANCE REQUIREMENTS

- A. *Variation of duct configuration or sizes other than those of equivalent or lower loss coefficient is not permitted except by written permission.*

1.5 SUBMITTALS

- A. *Provide submittals for all products and systems under this Section in accordance with Section 23 05 00 - Common Work Results for Mechanical and Division 1.*
- B. *Product Data:*
 - 1. *Submit data for duct materials and accessories.*
 - 2. *Submit manufacturers catalog literature for each item indicated on the Ventilation Equipment Schedule on Sheet MI.1.*
 - 3. *Submit manufacturers catalog literature for dampers, actuators, filters, and all other items specified herein.*
- C. *Shop Drawings: Submit shop drawings for fabrication of ductwork. Note that if ductwork will be fabricated exactly as indicated on the Drawings, the design Drawings can be submitted in lieu of shop drawings.*

1.6 CLOSEOUT

- A. *Division 1 - Closeout Requirements.*
- B. *Project Record Documents: Record actual locations of ducts and duct fittings. Record changes in fitting location and type. Show additional fittings used.*

1.7 QUALITY ASSURANCE

- A. *Division 1 – Quality Control*
- B. *Perform Work in accordance with SMACNA - HVAC Duct Construction Standards - Metal and Flexible and International Mechanical Code.*

1.8 QUALIFICATIONS

- A. *Manufacturer: Company specializing in manufacturing products specified in this section.*
- B. *Installer: Company specializing in performing work of this section.*

1.9 ENVIRONMENTAL REQUIREMENTS

- A. *Do not install duct sealant when temperatures are less than those recommended by sealant manufacturers.*
- B. *Maintain temperatures during and after installation of duct sealant.*

1.10 FIELD MEASUREMENTS

- A. *Verify field measurements prior to fabrication as required.*

PART 2 - PRODUCTS

2.1 MATERIALS

- A. *Galvanized Steel: ASTM A653/A653M galvanized steel sheet, lock-forming quality, having zinc coating in conformance with ASTM A90.*
- B. *Aluminum: Type 5052 alloy, minimum 0.090" thick.*
- C. *Fasteners: Rivets, bolts, or sheet metal screws except where indicated as welded.*
- D. *Sealants, Mastics and Tapes: Conform to UL 181A. Provide products bearing appropriate UL 181A markings.*

2.2 FABRICATION

- A. *Fabricate and support rectangular ducts in accordance with SMACNA HVAC Duct Construction Standards - Metal and Flexible and as indicated on the Drawings. Provide duct material, gages, reinforcing, and sealing for operating pressures indicated.*
- B. *Fabricate assemblies from galvanized steel or aluminum as indicated on the Drawings. Galvanized sheet metal assemblies shall have standard mechanical joints sealed airtight. Aluminum assemblies shall have continuous welded joints. Grind weld joints smooth after fabrication.*
- C. *Exterior Hood Fabrications: Fabricate all exterior hoods from minimum 0.090" thick Type 5052 aluminum using welded joints.*
- D. *Provide stainless steel mesh and frames where indicated on the Drawings.*

2.3 CONTROL DAMPER

- A. *Opposed blade low-leakage control damper, airfoil blades, galvanized steel construction, acetal bearings, stainless steel jamb seals, TPE blade seals. Greenheck VCD-33 or approved equal. See fabrication details on Drawings for sizes.*

2.4 ACTUATORS

- A. *On duct dampers install multi-voltage spring return actuator, Belimo AFBUP or approved equal.*

2.5 FILTERS

- A. *High capacity pleated panel filter, MERV 8 rating. Camfill 30/30 or approved equal. See fabrication details on Drawings for sizes.*

PART 3 - EXECUTION

3.1 EXAMINATION

- A. *Check equipment for damage that may have occurred during shipment. Repair damaged equipment as required or replace with new equipment.*

3.2 INSTALLATION

- A. Install Owner Furnished fabrications as indicated on Drawings.
- B. Caulk and seal to module as indicated on Drawings.
- C. Verify proper rotation and operation of fans.
- D. Adjust actuators to achieve damper full open to full close operation.
- E. Install one set of Owner Furnished air filters in all intake ducts. Deliver second set (spare) of Owner Furnished air filters to utility.

END OF SECTION

SECTION 23 35 17

ENGINE EXHAUST, CRANK VENT, AND CHARGE AIR SYSTEMS

Notes:

1. *All exhaust, crank vent, and charge air piping systems were furnished and partially installed as part of the prior module assembly contract. See Drawings for detail.*
2. *Temporary disassembly of exhaust, crank vent, and charge air piping through the module exterior wall for shipping is to be performed under this contract.*
3. *Final installation of exhaust and crank vent, and charge air piping and final piping insulation is to be performed under this contract. See Drawings for detail.*

PART 1 - GENERAL

1.1 SUMMARY

- A. Section includes:
 1. Engine Exhaust Piping and Accessories.
 2. Crank Vent Piping and Accessories.
 3. Charge Air Tubing and Accessories.

1.2 RELATED REQUIREMENTS

- A. Section 23 05 00 – Common Work Requirements for Mechanical.
- B. Section 23 05 29 - Hangers and Supports for Piping and Equipment.
- C. Section 23 07 19 - Piping Insulation.

1.3 REFERENCES

- A. American Society of Mechanical Engineers:
 1. ASME B31.1 –
 2. Power Piping.
 3. ASME B31.9 - Building Services Piping.
 4. ASME Section IX - Boiler and Pressure Vessel Code - Welding and Brazing Qualifications.

1.4 SYSTEM DESCRIPTION

- A. All fabrications and materials provided with module under assembly contract except as indicated below in Part 2 – Products.

1.5 SUBMITTALS

- A. Provide submittals for all products and systems under this Section in accordance with Section 23 05 00 - Common Work Results for Mechanical and Division 1.

- B. Product Data. Submit manufacturer's catalog information for the following:
 - 1. Flanges and Gaskets
- C. Welder's Certificate: Provide welder's certificate in accordance with Section 23 05 00 – Common Work Requirements for Mechanical.

1.6 QUALITY ASSURANCE

- A. Division 1 – Quality Control
- B. Perform Work in accordance with ASME B31.9 code for installation of piping systems and ASME Section IX for welding materials and procedures.
- C. Perform pipe welding with experienced welder with current API or equivalent certification for pipe welding in all positions.

1.7 QUALIFICATIONS

- A. Manufacturer: Company specializing in manufacturing products specified in this section.
- B. Fabricator or Installer: Company specializing in performing Work of this section.

1.8 DELIVERY, STORAGE, AND HANDLING

- A. Accept materials on site in shipping containers with labeling in place. Inspect for damage.
- B. Provide temporary end caps and closures on piping and leave in place until installation.

1.9 FIELD MEASUREMENTS

- A. Verify field measurements prior to fabrication.

PART 2 - PRODUCTS

2.1 FLANGED JOINTS

- A. Charge Air Flanges: 1/2" thick steel plate, ANSI 125/150# pattern for O.D. and bolting, I.D. sized for tubing insert connection.
- B. Charge Air Flange Bolts: Hot dip galvanized bolts, nuts, and washers. Coat with high temperature anti-seize prior to assembly.
- C. Flange Gaskets: Full face, rated for minimum 1000F continuous. Garlock 4122-FC, Metal Tech HT-195, or approved equal.

PART 3 - EXECUTION

3.1 EXAMINATION

- A. Check materials for damage that may have occurred during shipment. Repair damaged materials as required or replace with new materials.

3.2 REINSTALLATION – EXHAUST AND CRANK VENT PIPING

- A. Install new flange gaskets where piping is broken apart for shipping. See Shop/On-Site Notes on Drawings.
- B. Re-tighten all exhaust flange bolts after minimum one engine run/cool cycle.

3.3 PIPE INSULATION

- A. Reinstall pipe insulation and jacket as indicated in Shop/On-Site Notes on Drawings.
- B. Fill entire wall penetration void with mineral wool insulation, install cover plates, and seal as indicated on Drawings. See Shop/On-Site Notes.
- C. Insulate interior charge air tubing as indicated on the Drawings in accordance with Section 23 07 19.

3.4 INSTALLATION - CHARGE AIR TUBING

- A. Prepare pipe and install new weld flange pair as indicated on the Drawings. Wire brush flanges and weld area and cover with two coats of cold galvanizing compound to match adjacent tubing.
- B. Install all new flange gaskets.
- C. Coat all flange bolts and gaskets with high temperature anti-seize.
- D. Seal wall penetrations as indicated on the Drawings.

3.5 CHARGE AIR TUBING TESTING AND REPORTING

- A. Division 1 – Quality Control
- B. Provide notification and reporting in accordance with Section 23 05 00 – Common Work Requirements for Mechanical.
- C. Isolate engines and coolers prior to pressure testing.
- D. Test all Charge Air Tubing with minimum 50 psig air. Test 100% of welds visually for leaks with each joint soaked in a foaming soapy water solution, and visually inspect each joint for leaks. Isolate and pressure test each run of piping. Provide blind flanges, threaded caps, or plugs as needed. Do not conceal pipe joints before pressure testing is complete.

END OF SECTION

SECTION 26 05 00

COMMON WORK RESULTS FOR ELECTRICAL

PART 1 – GENERAL

1.1 SCOPE OF WORK

- A. The work to be included in these and all other electrical subsections shall consist of providing, installing, adjusting and setting into proper operation complete and workable systems for all items shown on the Drawings, described in the specifications or reasonably implied. This shall include the planning and supervision to coordinate the work with other crafts and to maintain a proper time schedule for delivery of materials and installation of the work.
- B. Provide the labor, materials, equipment and test equipment necessary to furnish, install, and place into operation the power, motor, lighting, control, alarm, and associated electrical systems of this Contract. Connect motors, meters, panels, sensors, switches, and outlets or any other electrical device installed or provided as part of the project. Mark and identify circuits, terminal boards, equipment, enclosures, etc. with identification numbers, wire numbers, nameplates, and warning signs. Test, adjust and calibrate equipment and start-up all electrical equipment and its associated mechanical attachments as necessary to place the project into operation.
- C. Local Conditions: The Contractor shall thoroughly familiarize himself with the work as well as the local conditions under which the work is to be performed. Schedule work with regard to seasons, weather, climate conditions, and all other local conditions which may affect the progress and quality of work.

1.2 RELATED REQUIREMENTS

- A. Division 1.
- B. All other Division 26 Specifications.
- C. See Divisions 21, 23, and 33 which contain information and requirements that apply to work specified herein.

1.3 CODES AND STANDARDS

- A. Codes: Perform all work in strict accordance with all applicable national, state, and local codes; including, but not limited to the latest legally enacted editions of the following specifically noted requirements:
 - 1. NFPA 70, National Electric Code – NEC.
 - 2. National Fire Protection Association (NFPA) NFPA 37.
 - 3. ANSI-C2, National Electrical Safety Code – NESC.
 - 4. International Building Code – IBC.
 - 5. International Fire Code – IFC.

- B. Standards: Reference to the following standards infers that installation, equipment, and materials shall be within the limits for which it was designed, tested, and approved, in conformance with the current publications and standards of the following organizations:
1. American National Standards Institute - ANSI;
 2. American Society for Testing and Materials - ASTM;
 3. American Society of Heating, Refrigerating and Air Conditioning Consultants - ASHRAE (Standard 90-75);
 4. Factory Mutual – FM;
 5. Institute of Electrical and Electronics Consultants - IEEE;
 6. National Electrical Contractors Association - NECA;
 7. National Electrical Manufacturers' Association - NEMA;
 8. National Fire Protection Association - NFPA, and
 9. Underwriters Laboratory - UL

1.4 QUALITY ASSURANCE

- A. Division 1 – Quality Control.
- B. Perform all work in accordance with above referenced codes and standards which are referenced to establish minimum requirements.
1. If the Contractor observes that the Drawings and/or Specifications are at variance with such codes and regulations, he shall promptly notify the Authority in writing.
 2. Should the Contractor perform any work in non-compliance with the above-mentioned codes and regulations without such notice to the Authority, the Contractor shall bear all costs arising therefrom.
- C. In addition, perform all work in accordance with the specific requirements of all Division 26 sections which follow. Wherever the specifications require higher grades of material or workmanship than required by the codes the specifications shall prevail.
- D. All electrical work shall be performed by Alaska licensed Journeyman Electricians or by licensed Apprentice Electricians under the direct supervision of a licensed Journeyman Electrician. Journeyman and Apprentice Electricians' current cards shall be available on the job site for review upon request.
- E. Perform all work in a neat and workmanlike manner using skilled craftsmen who are qualified and experienced in the specific type of work.
- F. Test all work as required by the specifications. Document all testing and submit results in accordance with specifications.

1.5 SPECIAL CONDITIONS AND REQUIREMENTS

- A. Ensure that the appropriate safety measures are implemented and that all workers are aware of the potential hazards from electrical shock, burn, noise, rotating fans, pulleys, belts, hot piping, etc. associated with working near power generation and related equipment.
- A. The Contractor is responsible for maintaining required clearspace. Should the Contractor become aware of a clearspace violation or if the installation of electrical equipment as shown produces a clearspace violation, notify the Authority in writing before proceeding with the installation.
- B. If hazardous location boundaries exist, they will be shown on the drawings. Locations for seal-off fittings shall be field determined by the Contractor.
- C. Wet Locations: Wet locations shall include all areas underground (below grade), in direct contact with the earth, areas subject to saturation with water or other liquids from splashing, surface water, exposed to the weather and unprotected.

1.6 DRAWINGS, SPECIFICATIONS & SYMBOLS

- A. The Drawings and Specifications are complementary; what is shown on one is as binding as if called for in both. Do not scale the Drawings. Locations of devices, fixtures, and equipment are approximate unless dimensioned.
- B. Drawing symbols used for basic materials, equipment and methods are commonly used by the industry and should be universally understood. Special items are identified by a supplementary list of graphical illustrations, or called for on the Drawings or in the specifications.

1.7 SPECIFIC TERMINOLOGY

- A. Streamlining: In many instances, the products, reference standards, and other itemized specifications have been listed without verbiage. In these cases, it is implied that the Contractor shall provide the products and perform in accordance with the references listed.
- B. "Furnish" means to purchase material as shown and specified, and cart the material to an approved location at the site or elsewhere as noted or agreed to be installed by supporting crafts.
- C. "Install" means to set in place and connect, ready for use and in complete and properly operating finished condition, material that has been furnished.
- D. "Provide" means furnish all products, labor, sub-contracts, and appurtenances required and install to a complete and properly operating, finished condition.
- E. "Product" is a generic term which includes materials, equipment, fixtures, and any physical item used on the project.
- F. "Accessible" means arranged so that an appropriately dressed man 6-foot 2 inches tall, weighing 250 pounds, may approach the area in question with the tools and products necessary for the work intended, and may then position himself to properly

perform the task to be accomplished, without disassembly or damage to the surrounding installation.

- G. "Serviceable" means arranged so that the component or product in question may be properly removed and replaced without disassembly, destruction, or damage to the surrounding installation.
- H. "Rough-in and Connect" means provide an appropriate system connection such as conduit with "J" boxes, wiring, switches, disconnects, etc., and all wiring connections. Equipment furnished is received, uncrated, assembled and set in place under the Division in which it is specified.

1.8 SUBMITTALS – GENERAL REQUIREMENTS

- A. Provide submittals for all products and systems described in Division 26 specifications and shown on the Drawings to demonstrate compliance with the requirements of the project. Provide submittals in the manner described herein and in Division 1 with an index following specification format and with item by item identification.
- B. Submittal review is for general design and arrangement only and does not relieve the Contractor from any of the requirements of the Contract Documents. Submittals will not be checked for quantity, dimension, fit or proper technical design of manufactured equipment. Where deviations of substitute product or system performance have not been specifically noted in the submittal by the Contractor, provision of a complete and satisfactory working installation of equal quality to system specified is the sole responsibility of the Contractor.
- C. Submittals shall demonstrate compliance with the requirements of the project. Furnish all relevant data as appropriate including but not limited to:
 - 1. Manufacturer's name and address, and supplier's name, address, and phone number.
 - 2. Catalog designation or model number with rough-in data and dimensions.
 - 3. Operation characteristics.
 - 4. Complete customized listing of characteristics required. Indicate whether item is "As Specified" or "Proposed Substitution." Indicate any deviations on submittal. Mark out all non- applicable items. The terminology "As Specified" used without this customized listing is not acceptable.
 - 5. Wiring diagrams for the specific system.
 - 6. Coordination data to check protective devices.
 - 7. Shop Drawings.
- D. Provide submittals for all materials and equipment in the Division 26 specification sections which follow and submit under that specification section.

1.9 SUBMITTALS UNDER THIS SECTION

- A. All materials in the Electrical Equipment Schedule on the Drawings.

- B. All materials in the Electrical Conductor Schedule on the Drawings.

1.10 RECEIVING AND HANDLING MATERIAL

- A. See General Conditions and Division 1 regarding material handling.
- B. Deliver packaged materials to the jobsite in unbroken packaging with manufacturer's label, and store to facilitate inspection and installation sequence.
- C. Protect all materials and equipment during the duration of construction work against contamination and damage. Replace or repair to original manufactured condition any items damaged during construction. Immediately report any items found damaged to the Authority prior to commencing construction.

1.11 TIMELY EXECUTION OF WORK

- A. The work must be expedited and close coordination will be required in executing the work. The various trades shall perform their portion of the work at such times as directed so as to meet scheduled completion dates, and to avoid delaying any other trade.
- B. The Authority will set up completion dates. Each Contractor shall cooperate in establishing these times and locations and shall process his work so as to ensure the proper execution of it.

1.12 LAYOUT AND COORDINATION OF WORK

- A. Drawings are partly diagrammatic and it is not the intent to show in detail all features of work or exact physical arrangement of equipment. The locations of outlets and equipment are approximate unless dimensioned. The exact locations and routing of conduits shall be governed by structural conditions and physical interferences and by the location of electrical terminations on equipment. Equipment shall be located and installed so that it will be readily accessible for operation and maintenance.
- B. If conduit is placed incorrectly with respect to equipment connections or if equipment connections are relocated without appropriate changes in the electrical work and the resulting work is not coordinated, the work affected shall be removed and re-installed at the Contractor's expense, even if removal and replacement of portions of work by other trades is necessary.
- C. The Contractor shall schedule his work to coordinate through the General Contractor and with all other subcontractors, power and telephone utilities in order to maintain job progress and to avoid conflicts with equipment installation or work done by the various trades.

1.13 COOPERATION AND CLEANING UP

- A. The Contractor for the work under each section of the specifications shall coordinate his work with the work described in all other sections of the specifications, and shall carry on his work in such a manner that none of the work under any section of these specifications shall be compromised, hindered, or delayed at any time.

- B. At all times during the progress of the work, the Contractor shall keep the premises clean and free of unnecessary materials and debris. The Contractor shall, on direction at any time from the Authority, clear any designated area or areas of materials and debris. On completion of any portion of the work, the Contractor shall remove from the premises all tools and machinery and all debris occasioned by the work, leaving the premises free of all obstructions and hindrances.

1.14 PROJECT RECORD DRAWINGS

- A. In accordance with the requirements of Division 1 maintain record documents at the project site and make available for review by the Authority upon request.
- B. Mark up a clean set of drawings as the work progresses to show the dimensioned location and routing of all mechanical work which will become permanently concealed. Show routing of work in concealed below grade or in blind spaces within the building.
- C. At completion of project, deliver record documents in accordance with Division 1.

1.15 ELECTRICAL SYSTEMS TESTING AND REPORTING REQUIREMENTS

- A. Division 1 - Closeout Requirements.
- B. In addition to field testing, the Contractor shall perform all shop tests for fabricated items such as switchgear and engine-generators as required by the Division 26 specification sections which follow.
- C. Field testing shall include but not be limited to:
 - 1. Continuity of all circuits.
 - 2. Correct phase rotation.
 - 3. Megger test of all conductors size #2AWG and larger.
 - 4. Correct rotation of all motors.
 - 5. Proper function of all switches and devices.
 - 6. Proper function of all control systems.
- D. Note that final field testing and commissioning of the switchgear and engine-generators will be performed by the Authority after substantial completion.
- E. Notify the Authority in writing seven (7) days in advance of tests. The Authority shall have the option to be present at all testing.
- F. Provide written documentation of all tests. The Contractor may use their own test forms or upon request the Authority can provide forms for common tests. Test reports shall include at a minimum the following information: item or system identification, air temperature, time, date, signature of person performing test, and photographs of testing in progress.
- G. Where tests disclose problem areas, retest after the defect has been corrected. Retesting after the repair of defects shall be performed at no cost to the Authority.

- H. Submit completed results of final successful tests along with photographs to the Authority for approval prior to Substantial Completion.

1.16 ELECTRICAL DEVICE CALIBRATION REQUIREMENTS

- A. Division 1 – Quality Control.
- B. Division 23.
- C. Calibrate all electrical and electronic measuring devices as indicated on the Drawings and in the Division 26 sections that follow.
- D. Support other trades as required with calibration of electronic devices furnished under Division 23.

1.17 SUBSTANTIAL COMPLETION

- A. In accordance with Section 01 77 00 - Contract Closeout Procedures, provide advance written notice to the Authority to schedule substantial completion inspection. Submit all required documents and ensure all conditions have been met.
- B. Provide Authority access to the site. Provide on-site transportation, ladders, lifts, etc. for inspection and testing of the work.
- C. Cooperate with the Authority and provide assistance at all times for the inspection of the electrical work performed under this Contract. Remove covers, operate machinery, or perform any reasonable work which, in the opinion of the Authority, will be necessary to determine the completeness, quality, or adequacy of the work.
- D. Conduct operating tests and demonstrate that all systems operate satisfactorily in accordance with requirements of Contract Documents. Should a portion of installation fail to meet requirements of Contract Documents, repair or replace items failing to meet requirements until items can be demonstrated to comply.
- E. Have instruments available for measuring voltage and current values and for demonstration of continuity, ground, or open circuit conditions. Provide services of qualified technicians familiar with equipment and systems to assist in taking measurements and making tests.
- F. Assist the Authority in instruction of operators on the proper operation and maintenance of all systems and equipment under this contract. Provide services of qualified technicians familiar with each item or system.

1.18 FINAL COMPLETION

- A. In accordance with Section 01 77 00 - Contract Closeout Procedures, provide notification of completion. Submit all required documents and ensure all conditions have been met.

1.19 WARRANTY

- A. In accordance with Section 01 73 00 – Execution Requirements, provide warranties for all systems and equipment.

- B. See Division 26 sections that follow for specific equipment warranty requirements. Wherever the Division 26 specifications have more stringent warranty requirements than Division 1, the Division 26 requirements shall prevail.

PART 2 – PRODUCTS

2.1 ELECTRICAL EQUIPMENT

- A. Provide all materials in the Electrical Equipment Schedule on the Drawings.

2.2 ELECTRICAL CONDUCTORS

- A. Provide all materials in the Electrical Conductor Schedule on the Drawings.

PART 3 – EXECUTION (NOT USED)

END OF SECTION

SECTION 26 05 02
BASIC ELECTRICAL MATERIALS AND METHODS

PART 1 – GENERAL

1.1 SCOPE OF WORK

- A. This Section describes specific requirements, products, and methods of execution which are typical throughout the Electrical Work of this Project. Additional requirements for the specific systems will be found in the Division specifying those systems.

1.2 RELATED REQUIREMENTS

- A. This section applies to all Division 26 work.
- B. See Divisions 23, 27, and 33 which contain information and requirements that apply to work specified herein.

1.3 COORDINATION

- A. Layout all the work in advance and avoid conflict with other Work in progress. Physical dimensions shall be determined from Drawings and field measurements. Verify locations for junction boxes, disconnect switches, stub-ups, etc., for connection to equipment furnished by others, or in other Divisions of this Work.

1.4 SERVICEABILITY OF PRODUCTS

- A. Furnish all products to provide the proper orientation of serviceable components to access space provided.
- B. Coordinate installation of all products to allow proper service areas for any items requiring periodic maintenance inspection or replacement.
- C. Replace or relocate all products incorrectly ordered or installed.

1.5 ACCESSIBILITY OF PRODUCTS

- A. Arrange all work to provide access to all serviceable and/or operable products. Layout work to optimize net usable access space within confines of space available. Advise the Authority, in a timely manner, of areas where proper access or required clearspace cannot be maintained. Furnish Layout Drawings to verify this claim, if requested.
- B. Provide access doors in ceilings, walls, floors, etc., for access to j-boxes, automatic devices, and all serviceable or operable equipment in concealed spaces.

PART 2 – PRODUCTS

2.1 PRODUCTS FURNISHED IN DIVISION 26

- A. All products furnished and installed in permanent construction shall be new, full-weight, standard in every way, and in first class condition.

- B. All equipment furnished by the Contractor shall be listed by and shall bear the label of Underwriters' Laboratories, Incorporated (UL) or equivalent independent testing laboratory.
- C. All products of similar class or service shall be of one manufacturer.
- D. Capacities, sizes, and dimensions given are minimum unless otherwise indicated. All systems and products shall be subject to review for adequacy and compliance with Contract Documents.

2.2 PRODUCTS FURNISHED IN OTHER DIVISIONS

- A. Controls, including conduit, wiring, and control devices required for the operation of systems furnished in other Divisions shall be installed in accordance with Division 26 Specifications.
- B. All equipment furnished by the Contractor shall be listed by and shall bear the label of Underwriters' Laboratories, Incorporated (UL) or equivalent independent testing laboratory.
- C. Provide complete power connections to equipment including but not limited to feeders, connections, disconnects and motor running overcurrent protection. Where starters are provided as part of a packaged product, overcurrent devices shall be provided.

2.3 IDENTIFICATION

- A. Equipment Nameplates:
 - 1. Provide rigid engraved nameplates of laminated plastic 1/16-inch thick with white letters on a black or gray background. Nameplates for emergency equipment shall be red with white letters.
 - a. Securely attach nameplates with two screws, minimum.
 - b. Temporary markings not permitted on equipment. Repaint trims housings, etc., where markings cannot be readily removed. Refinish defaced surfaces.
 - c. No labeling abbreviations will be permitted without prior approval.
 - 2. Nameplate Locations:
 - a. Provide 1/2-inch minimum height letters on following equipment:
 - 1) Service disconnects (red background).
 - 2) Secondary feeder breakers in distribution equipment. Designation as required by load served.
 - 3) Special equipment housed in cabinets, as designated on Drawings, on outside of door.
 - b. Provide 1/4-inch minimum height letters on:

- 1) Disconnects and starters for motors or fixed appliances - (include item designation and branch feeder circuit number); and
 - 2) Designated electrical equipment.
- B. Branch Circuit Panelboard Schedules: Provide neatly typed schedule (odd numbered circuits on left side or top, even on right side or bottom) under plastic jacket or protective cover to protect the schedule from damage or dirt. Securely mount on inside face of panelboard door. Define briefly, but accurately, nature of connected load (i.e., Lighting, interior; receptacles, work bench; etc.) as approved.
- C. Conduit Labeling: Unless a conduit is completely exposed and the purpose is clearly obvious, all conduits shall be permanently marked using a label maker.
1. Conduits Entering Panels: All conduits entering panels shall be labeled with the circuit numbers of the circuits contained inside.
 2. Concealed Conduits: Conduits that are concealed inside building structure or below grade shall be marked at each with the designation of the opposite end.
 3. For interior conduits the label shall be applied directly to the conduit. For exterior conduits the label shall be applied inside the junction box or conduit body where the conduit terminates.
- D. Junction Boxes: All junction boxes with steel covers shall be permanently marked using a label maker with the circuit numbers of wiring inside. For interior locations the label shall be applied on the outside and for exterior locations the label shall be applied inside the junction box.
- E. Conductors:
1. Conductors shall be color coded as indicated on the Electrical Conductor Schedule on the Drawings.
 2. Control and alarm circuit conductors
 - a. Field conductors shall be identified by destination panel and terminal block designations.
 - b. Internal (Control Panel) numbering system shall be provided by the Contractor or panel Fabricator. The numbering system shall assign each logical conductor set a unique identification number that will be reflected on the as-built drawings.

PART 3 – EXECUTION

3.1 STORAGE AND HANDLING

- A. Division 1 – Material and Equipment.
- B. All items shall be delivered and stored in original containers, which shall indicate manufacturer's name, the brand, and the identifying number.

- C. Items subject to moisture and/or thermal damage shall be stored in a dry, heated place.
- D. All items shall be covered and protected against dirt, water, chemical and/or mechanical damage.

3.2 PROTECTION OF PRODUCTS

- A. The Contractor shall be held responsible for products to be installed under this Contract.
- B. The Contractor will be required to make good, at his own cost, any injury or damage which said products may sustain before Final Acceptance.

3.3 INSTALLATION

- A. All products shall be installed by skilled craftsmen. The norms for execution of the work shall be in conformity with NEC Chapter 3 and the NECA "Standards of Installation," which herewith is made part of these Specifications.
- B. Provide working space in accordance with NEC 110.26 to permit ready and safe operation and maintenance of equipment.
- C. Installation of all equipment shall be in accordance with manufacturer's instructions.

3.4 SUPPORT SYSTEMS

- A. All interior materials used shall be galvanized or zinc plated.
- B. All exterior materials used shall be hot dip galvanized. Where support elements are field cut, exposed metal shall be coated with spray-on cold galvanizing.
- C. Support from structure or as specifically detailed on the Drawings.
- D. Conduits shown to be run at grade shall be supported by sleepers as shown on the drawings. Conduits may share fuel piping sleepers if installed such that neither system will require removal during maintenance or replacement.

3.5 MOUNTING HEIGHTS

- A. Mounting heights shall be above finished floor (AFF) or above finished grade as noted below, unless otherwise shown or indicated.
 - 1. Lighting Switches, 48 inches to center
 - 2. Receptacles shall be mounted as indicated on the Drawings.
- B. Other mounting heights are indicated on the Drawings by detail.

3.6 CUTTING AND PATCHING

- A. Where previously completed building surfaces or other features must be cut, penetrated, or otherwise altered, such work shall be carefully laid out and patched in a neat and workmanlike manner to the original condition. Perform work only with craftsmen skilled in their respective trades.

- B. Do not cut, drill, or notch structural members unless specifically approved by the Authority. Minimize penetrations and disruption of building features

3.7 FLASHING AND SEALING

- A. Seal all interior and exterior wall penetrations with polyurethane caulking. Seal both sides of walls where accessible.

3.8 PROTECTIVE FINISHES

- A. Take care not to scratch or deface factory finish on electrical apparatus and devices. Repaint all marred or scratched surfaces.
- B. Provide hot dip galvanized components for ferrous materials installed in exterior locations.

3.9 CLEAN-UP AND COMMISSIONING

- A. Throughout the Work, the Contractor shall keep the work area neat and orderly by periodic clean-ups.
- B. As independent parts of the installation are completed, they may be commissioned and utilized during construction.

END OF SECTION

SECTION 26 05 26

GROUNDING AND BONDING FOR ELECTRICAL SYSTEMS

PART 1 – GENERAL

1.1 SCOPE OF WORK

- A. This section describes general requirements, products, and methods of execution relating to the furnishing and installation of a complete grounding system as required for this project.

1.2 RELATED REQUIREMENTS

- A. Section 26 05 00 Common Work Results for Electrical.
- B. Section 26 05 02 Basic Materials and Methods.
- C. Division 33.

1.3 MINIMUM REQUIREMENTS

- A. The minimum requirement for the system shall conform to Article 250 of the NEC.

1.4 SUBMITTALS

- A. Product Data: Provide in accordance with Section 26 05 00 Common Work Results for Electrical and Division 1.

PART 2 – PRODUCTS

2.1 GENERAL

- A. Install types indicated and of sizes and ratings to comply with NEC. Where types, sizes, ratings, and quantities indicated are in excess of NEC requirements, the more stringent requirements and the greater size, rating, and quantity indications shall govern.
- B. Material: Copper only. Aluminum is not acceptable for use in any location.

2.2 GROUNDING ELECTRODES

- A. Copper clad steel with high-strength steel core and electrolytic-grade copper outer sheath, molten welded to core. Size as indicated on the Drawings.

2.3 WIRE AND CABLE CONDUCTORS

- A. Ground Grid or Grounding Electrode Conductors shall be bare copper conductors conforming to the following:
 - 1. Solid Conductors: ASTM B-3.
 - 2. Stranded Conductors: ASTM B-8.
 - 3. Tinned Conductors: ASTM B-33.
- B. Station Service Circuit Grounding Conductor: General use conductors in accordance with the conductor schedule, green insulated. Minimum No. 12 AWG.

- C. Generator and Feeder Circuit Grounding Conductor: Equivalent to the phase conductors in accordance with the conductor schedule, size as indicated.

2.4 MISCELLANEOUS CONDUCTORS

- A. Ground Bus: Bare annealed copper bars of rectangular cross section.
- B. Braided Bonding Jumpers: Copper tape, braided No. 30 gauge bare copper wire, terminated with copper ferrules.
- C. Bonding Strap Conductor/Connectors: Soft copper, 0.05-inch-thick and 2 inches wide, except as indicated

2.5 GROUND CONNECTIONS

- A. All underground ground connections shall be made with exothermic welds.
- B. Wherever the ground rod crosses the ground grid it shall be connected.
- C. Grounding conductor connections to building structure and to equipment skids shall be made with mechanical lugs or compression lugs as indicated. Drill and tap steel structure and equipment and fasten with stainless steel bolts for positive bond to clean bare steel threads.

PART 3 – EXECUTION

3.1 SERVICE AND STRUCTURE GROUND

- A. Create a Grounding Electrode System (GES) for this project by connecting the following:
 - 1. Generators, switchgear, and transformers grounded as shown on the Drawings.
 - 2. Building structure and equipment skids as shown on the Drawings.
 - 3. Other items or equipment grounded as indicated on the Drawings.
 - 4. The neutral conductors grounded only where specifically indicated on the Drawings.
- B. Current carrying capacity of the grounding and bonding conductors shall be in conformity with Tables 250.66 and 250.122 of the NEC.

3.2 EQUIPMENT GROUND

- A. The raceway system shall be bonded in conformity with NEC requirements to provide a continuous ground path. Where required by code or where called for on the Drawings, an additional grounding conductor shall be sized in conformity with Table 250.122 of the NEC.
- B. Provide a separate copper equipment grounding conductor for each feeder and for each branch circuit indicated. Install the grounding conductor in the same raceway with the related phase and neutral conductors, and connect the grounding conductor to pull boxes or outlet boxes at intervals of 100 feet or less. Where paralleled conductors in separate raceways occur, provide a grounding conductor in each

raceway. Connect all grounding conductors to bare grounding bars in panel boards, and to ground buses in service equipment to the end that there will be an uninterrupted grounding circuit from the point of a ground fault back to the point of connection of the equipment ground and system neutral. All grounding conductors shall be sized in conformity with Table 250.122 of the NEC.

- C. Provide separate grounding conductor securely bonded and effectively grounded to both ends of all non-metallic raceways and all flexible conduit.
- D. If non-metallic enclosures are provided, all metal conduits terminating or entering the enclosure shall be bonded together with approved bonding bushings and minimum #6 AWG copper cable.

END OF SECTION

SECTION 26 05 29

HANGERS AND SUPPORTS FOR ELECTRICAL SYSTEMS

PART 1 – GENERAL

1.1 SCOPE OF WORK

- A. Support and align raceways, cabinets, boxes, fixtures, etc., in an approved manner and as specified.

1.2 RELATED REQUIREMENTS

- A. Section 26 05 00 Common Work Results for Electrical.
- B. Section 26 05 02 Basic Materials and Methods.
- C. Section 26 05 33 Raceway and Boxes for Electrical Systems.
- D. Division 33.

1.3 SUBMITTALS

- A. Shop Drawings and Product Data: Provide in accordance with Section 26 05 00 Common Work Results for Electrical and Division 1.

PART 2 – PRODUCTS

2.1 HANGERS AND SUPPORTS

- A. Support equipment and raceways on strut, brackets, trapeze hangers, or as detailed. Anvil, B-Line, Grinnell, Unistrut, or approved equal.

2.2 FORMED STEEL CHANNEL

- A. Strut: Cold formed mild steel channel strut, pre-galvanized finish and slotted back unless specifically indicated otherwise.
- B. Standard Strut: 12 gauge thick steel, 1-5/8" x 1-5/8", B-line B22-SH-Galv or approved equal.
- C. Double Strut: 12 gauge thick steel, 1-5/8" x 3-1/4", B-line B22A-SH-Galv or approved equal.
- D. Shallow Strut: 14 gauge thick steel, 1-5/8" x 13/16", B-line B54-SH-Galv or approved equal.
- E. On all exterior installations provide hot dip galvanized strut and fittings.

2.3 FITTINGS AND ACCESSORIES

- A. Hanger Rods: Continuous threaded rod. Zinc plated carbon steel except for exterior installations provide hot dip galvanized.
- B. Provide fittings, brackets, channel nuts, and accessories designed specifically for use with specified channel strut. Zinc plated carbon steel except for exterior installations provide hot dip galvanized.

- C. Pipe Clamps: Two piece pipe clamp designed to support pipe tight to strut, B-line B20##, or approved equal. Zinc plated carbon steel except for exterior installations provide hot dip galvanized
- D. Fasteners: All bolts, nuts, and washers to be zinc plated carbon steel except on exterior installations provide hot dip galvanized or stainless steel.

2.4 EARTHQUAKE ANCHORAGE

- A. Anchor equipment weighing more than 100 pounds to the building structure to resist lateral earthquake forces.
- B. Total lateral (earthquake) force shall be 1.00 times the equipment weight acting laterally in any direction through the equipment center of gravity. Provide adequate backing at structural attachment points to accept the forces involved.
- C. Provide equipment supported by flexible isolation mounts with earthquake restraining supports positioned as close to equipment as possible without contact in normal operation (earthquake bumpers). The maximum lateral displacement due to the computed earthquake force from above shall not exceed 1.5 inches.

PART 3 – EXECUTION

3.1 INSTALLATION

- A. Conduits and equipment shall be mounted using strut or similar supports unless otherwise noted.
- B. Support material shall be cut square and smooth using a floor mounted bandsaw or chop saw. Hacksaws shall not be used to cut support material.
- C. Do not strap conduits to piping except where specifically detailed on the Drawings. When run in parallel with piping maintain adequate separation to allow maintenance to take place on either piping or conduit system so that the other does not have to be removed when maintenance is required.
- D. Conduits shown to be run at grade shall be supported by sleepers as shown on the drawings. Conduits may share fuel piping sleepers if installed such that neither system will require removal during maintenance or replacement.

END OF SECTION

SECTION 26 05 33
RACEWAY AND BOXES FOR ELECTRICAL SYSTEMS

PART 1 – GENERAL

1.1 SCOPE OF WORK

- A. This section describes specific requirements, products, and methods of execution relating to conduit and conduit fittings approved for use on this project. Type, size and installation methods shall be as shown on the Plans, required by Code and specified in these specifications.

1.2 RELATED REQUIREMENTS

- A. Section 26 05 00 Common Work Results for Electrical.
- B. Section 26 05 02 Basic Materials and Methods.
- C. Section 26 05 26 Grounding and Bonding for Electrical Systems.
- D. Section 26 05 29 - Hangers and Supports for Electrical Systems.
- E. Division 33.

1.3 QUALITY ASSURANCE

- A. Conduit and conduit fittings shall be standard types and sizes as manufactured by a nationally recognized manufacturer of this type of materials and be in conformity with applicable standards and UL listings.

1.4 SUBMITTALS

- A. Shop Drawings and Product Data: Provide in accordance with Section 26 05 00 Common Work Results for Electrical and Division 1.

PART 2 – PRODUCTS

2.1 GALVANIZED RIGID CONDUIT (GRC)

- A. Galvanized rigid conduit shall be mild steel with continuous welded seam, hot-dip galvanized complying with ANSI C80.1 and shall be UL listed.
- B. Elbows, bends, and fittings shall be made of full weight materials complying with the above and shall be coated and threaded the same as conduit.
- C. Threads for conduit shall be tapered and clean cut. All threads shall be hot dip galvanized after cutting.
- D. Conduit shall be 1/2-inch trade size or larger.

2.2 ELECTRICAL METALLIC TUBING (EMT)

- A. Steel tubing, galvanized outside and provided with a slick corrosion resistant interior coating; UL listed and labeled according to Standard 797; conforming to ANSI Standard C80.3.

2.3 LIQUIDTIGHT FLEXIBLE METAL CONDUIT

- A. Liquidtight flexible conduit shall be manufactured from galvanized steel strip, sealed with a polyvinyl outer jacket and shall be UL listed.
- B. Fittings shall be designed for use with liquidtight flexible conduit and shall maintain electrical continuity throughout fittings and conduit.
- C. Liquidtight flexible metal conduit shall be 1/2-inch trade size or larger and shall be manufactured by O-Z/Gedney Co., Southwire Co., or approved equal.

2.4 FITTINGS

- A. Conduit bodies shall be factory made with threaded hub connections and weather tight screw type covers. For all exterior locations provide malleable iron conduit bodies with hot dipped galvanized finish.
- B. Fittings utilized with rigid steel shall be galvanized steel. Conduit bushings shall be of the insulated type. Where grounding bushings are required, insulated grounding bushings with pressure type lugs shall be provided. Lock rings shall be of the sealing gland type. Provide conduit bushings on all penetrations without hubs.
- C. Couplings and Terminations for Electrical Metallic Tubing (EMT): Join lengths of EMT with steel compression type couplings and connectors. The connectors shall have insulated throats or a smooth interior so as not to damage the insulation during pulling operations.
- D. Fittings for liquid-tight flexible conduit shall be steel or malleable iron, of a type incorporating a threaded grounding cone, nylon or plastic compression ring, and a tightening gland, providing a low resistance ground connection. All throats shall be insulated.

2.5 JUNCTION BOXES AND ENCLOSURES

- A. Metallic device/junction boxes for interior use with Electrical Metallic Tubing (EMT) shall be minimum .0625" thick SAE 1008 pressed steel with galvanized finish, 2-1/8" deep welded or drawn construction with 1/2" and 3/4" knockouts. Provide with 1/2" raised face metal covers.
- B. For interior electrical junction boxes larger than 4" square provide NEMA 1 steel wall mount screw cover enclosures. Minimum 12-gauge steel with color ANSI 61 gray powder coated finish. Hoffman, B-Line, or approved equal. Provide with plated or stainless-steel cover screws.
- C. Weatherproof gang boxes for exterior use and where specifically indicated shall be die cast zinc metal with powder coated finish and threaded hubs. Provide with matching weatherproof gasketed covers and mounting hardware.

2.6 FINISHED SURFACE MOUNTED RACEWAY

- A. Where specifically indicated on the Drawings to install conductors in Wiremold, provide complete system of surface mount raceway.

- B. System shall be low profile surface mount raceway, Legrand Wiremold 500 Series or approved equal. Provide a complete system including raceway, fittings, connectors, couplings, boxes, transition fittings and other components required to integrate with both new and existing electrical systems.
- C. All exposed components shall be finish coated, color ivory.

PART 3 – EXECUTION

3.1 CONDUIT USAGE

- A. INTERIOR - All interior locations shall be electrical metallic tubing (EMT) except where specifically indicated as GRC.
- B. EXTERIOR - All exterior above grade locations shall be galvanized rigid conduit (GRC).
- C. Liquidtight flexible metal conduit shall be used in lengths of 18 to 24 inches for connections to motors or equipment subject to vibration and where indicated on the Drawings. Longer lengths may be used for equipment connection if grounding conductor is installed through conduit.
- D. FINISHED AREAS – In existing finished interior spaces install surface mount raceway where indicated on the Drawings.

3.2 CONDUIT INSTALLATION, GENERAL

- A. Conduit field joints shall be cut square and reamed smooth. Threads shall be cleanly cut and joints drawn up tight. Running threads shall not be permitted.
- B. After cutting and threading exterior GRC, threads shall be cleaned and degreased and shall receive two coats of cold galvanizing compound.
- C. Offsets and bends shall be made carefully, without reducing cross sectional area, and shall not be less than the radius of standard elbows.
- D. Convenience outlets, switches, and other devices located on walls shall be serviced from above, unless otherwise indicated.
- E. Raceways penetrating vapor barriers or traversing from warm to cold areas shall be sealed (at the penetration point) with a non-hardening duct sealing compound to prevent the accumulation of moisture.
- F. Provide seal off fittings when crossing hazardous boundaries into non-hazardous locations and at enclosures where required by Code. Not all locations where these fittings are required are shown.
- G. All metal conduits shall have insulating bushings and shall have locknuts inside and outside of enclosure box, etc. Conduits smaller than 1-1/4-inch trade size shall be equipped with bushings and shall have locknuts inside and outside of enclosure.

- H. All conduit runs shall be grounded in an effective and approved manner at point of origin and shall maintain a continuous ground throughout all runs, cabinets, pull boxes, and fittings from point of service to all outlets.
- I. Conduit Supports:
 - 1. Support conduits by wall brackets, pipe straps and strut sections, or trapeze hangers spaced not more than 10 feet on center.
 - 2. Conduits shall be supported from the structural system. Provide additional support as required for junction and pull boxes.
- J. All conduit runs shall be completed and cleaned free from foreign matter inside before conductors are drawn in. After installation conduit ends shall be plugged or capped to prevent the entrance of foreign materials.
- K. All conduits and junction boxes shall be permanently labeled in accordance with Section 26 05 02.
- L. All conduits not used by this Contract shall have a pull wire installed and securely tied off at each end for future conductor installation.

END OF SECTION

SECTION 31 11 00
CLEARING AND GRUBBING

PART 1 - GENERAL

1.1 SCOPE OF WORK

- A. This item consists of furnishing all labor, equipment, supplies, and material in performance of all operations required for site clearing, grubbing and clean-up operations.

1.2 RELATED REQUIREMENTS

- A. Section 31 23 00 - Excavation and Fill.
- B. Section 31 23 19 - Dewatering and Control of Surface Water.
- C. Section 02 41 00 – Demolition.

1.3 DEFINITIONS

- A. Clearing: Includes cutting all brush, trees and stumps, to within 2 inches of natural ground, chipping and disposing of the cuttings. Clearing also includes the removal of all snow and ice in the project area.
- B. Grubbing: Includes the removal and disposal of all stumps, roots, organics, buried logs, brush and other objectionable material down to in-situ mineral soils.

PART 2 - PRODUCTS

Not used.

PART 3 - EXECUTION

3.1 GENERAL

- A. Contractor shall perform all clearing and grubbing operations where designated on the Drawings and as specified herein or as directed by the owner.
 - 1. Locate, identify and protect utilities from damage.
 - 2. Verify with the Owner any vegetation to remain.
- B. The project site may contain miscellaneous debris including connexes, inoperable construction equipment, construction material, and other debris. Contractor shall relocate all materials, waste, and equipment that interfere with proposed improvements to approved location onsite in accordance with Demolition Specification 02 41 00.

3.2 PROTECTION

- A. Provide protection as necessary to prevent damage to existing improvements and utilities indicated to remain.

1. Protect improvements on adjoining properties and on project site.
 2. Protect trees, plant growth and features designated to remain. Protect survey benchmarks, property corners, survey monuments, light poles, and existing work from damage or displacement.
- B. All property corners, benchmarks or other permanent survey marker disturbed during construction shall be removed and recorded. The Contractor shall be responsible for the resurvey and resetting of any disturbed property corners, benchmarks or other permanent survey markers by a professional land surveyor, licensed by the State of Alaska.

3.3 USE AND DISPOSAL OF GRUBBED MATERIAL

- A. Cleared and grubbed material shall be disposed of at a Contractor furnished disposal area.
- B. Except as otherwise stated, the Contractor shall make their own arrangements and assume all cost in connection with disposal sites. Disposal sites shall be located and maintained in such a manner as to prevent a public nuisance.
- C. If the disposal site is located on private land, the Contractor shall obtain written permission from the property owner or owners for such disposal sites and shall furnish the Authority with a copy of this permission. The written permission shall specifically provide that the property owner will not hold the Authority, its employees, agents, or engineers liable for use or damage to this property. The Contractor shall be liable for any trespass and property damage incurred as a result of utilizing the disposal site.

END OF SECTION

SECTION 31 23 00
EXCAVATION AND FILL

PART 1 - GENERAL

1.1 SCOPE OF WORK

- A. This item consists of furnishing all labor, equipment, supplies, and material in performance of all earthwork operations including construction of foundations, earthen pads/embankments, access road(s), laydown areas, and other applicable features of the Work.
- B. Contractor shall make their own determination of the adequacy of the site to support equipment and other construction loads. Additional fill material and/or crane mats may be required to support loads during construction and Contractor shall provide additional fill and/or crane mats as required at no additional cost to the Authority.

1.2 RELATED REQUIREMENTS

- A. Division 1.
- B. Section 07 21 00 - Thermal Insulation.
- C. Section 02 32 00 - Geotechnical Investigations.
- D. Section 31 23 33 - Trenching and Backfill For Utilities.

1.3 QUALITY CONTROL ASSURANCE

- A. Materials high in chloride content, such as beach sand or gravel, shall not be used in contact with steel fittings or appurtenances.
- B. Materials may be tested on a case-by-case basis as directed by the Engineer.
 - 1. Gradation Analysis: ATM T-7, ASTM C136 or AASHTO T-27.
 - 2. Other testing procedures and methods referenced in individual specification sections.

1.4 SUBMITTALS

- A. Submit certified gradation analysis for any non-local fill material. Submit not less than 14 days prior to shipment.

1.5 MATERIAL SOURCES

- A. Imported Gravel Fill Material is not available locally and must be imported.
- B. Classified Fill may be available locally in the community or within the region. Contractor responsibilities shall include, but not be limited to, verification of available quantities, procurement of fill, transportation, processing, testing, offloading, storage, placement, and compaction.
- C. It is the responsibility of the Contractor to select a material source for the

project and supply material that meets the requirements for Classified Fill materials.

- D. The Contractor shall coordinate as necessary with the borrow pit surface and subsurface property owners, shall acquire all necessary permits and/or material sales agreements, and shall pay all required fees, royalties, and other costs associated with pit access and material extraction.
- E. The Authority is not responsible for fill lost during transportation.

PART 2 - PRODUCTS

2.1 UNCLASSIFIED EXCAVATION

- A. Excavation from the project area shall be considered unclassified. Complete all excavation as shown on the Drawings and/or at the direction of the Authority regardless of the type, nature, or condition of the materials encountered.
- B. Excavation conforming to the specifications for Classified Fill Materials may be reused. Unclassified excavation intended for reuse shall be stockpiled for placement in the work.
- C. Dispose of unusable excavation at a location provided by Contractor and approved by the Authority.

2.2 CLASSIFIED FILL MATERIALS

- A. Classified Fill Material shall consist of unfrozen silty sand and gravel mineral soil, free from dirt, muck, frozen chunks, clay balls, roots, organic material, debris, or deleterious material. Particle size shall not exceed 2 inches.
- B. Pipe Bedding Material shall be Classified Fill Material with particle size not to exceed 1 inch.

2.3 IMPORTED GRAVEL FILL MATERIALS

- A. Imported Gravel Fill Material shall meet the requirements of ADOT&PF Aggregate for Surface Course "E1" and shall consist of crushed stone or gravel consisting of sound, tough, durable pebbles or rock fragments containing no muck, peat, frozen material, roots, sod, or other deleterious matter.

PART 3 - EXECUTION

3.1 GENERAL

- A. Safety – The Contractor shall be solely responsible for making all excavations in a safe manner. Provide appropriate measures to retain excavation sideslopes and prevent sloughing to ensure that persons working in or near the excavation are protected.
- B. Notify the Authority of any discrepancies between Contractual requirements and site conditions prior to start of Work.

- C. Maintain subgrade, backfill and embankment areas or lifts open until testing is complete and testing requirements are met, or approval of testing is secured from the Authority.
- D. Any work covered up prior to approval by the Authority shall be excavated and reconstructed at no cost to the Authority.
- E. Work in inclement weather is at Contractor's risk. Any materials which become unstable as the result of improper moisture content, improper selection of techniques, equipment, or operations during inclement wet weather shall be replaced at no cost to the Authority.
- F. Excavations and embankment shall be accomplished in such a manner that drainage is maintained at all times; any areas not so drained shall be kept free of standing water by pumping if necessary.
- G. The Contractor shall provide for the proper maintenance of traffic flow and accessibility as may be necessary, and shall also make adequate provisions for the safety of property and persons.
- H. No separate payment for any excavation will be made. All excavation shall be incidental to the Bid Item being performed.

3.2 EXCAVATION

- A. Excavate to lines and grades shown on the Drawings. Remove and dispose of all topsoil, dirt, muck, frozen chunks, clay balls, roots, organic material, debris, or other deleterious material.
- B. At Contractor's option, unclassified excavation may be stockpiled and tested for conformance with classified fill specifications. See Part 1 of this specification for testing requirements.
- C. Disposal of Excess Excavation:
 - 1. Dispose of all excess excavated materials offsite. Contractor shall make arrangements for the disposal of the excavated material and bare all costs incidental to such disposal.
 - 2. Sideslopes of excavation waste piles shall be sloped to match the materials natural angle of repose, or flatter.
 - 3. Excavation waste areas shall be completely within the limits of the disposal area property.
- D. Dewatering:
 - 1. Excavate all materials in a dewatered condition unless approved otherwise by the Authority.
 - 2. Dewatering shall be performed in accordance with the requirements of Section 31 23 19, Dewatering and Control of Surface Water.
- E. Unauthorized Excavation:
 - 1. Unauthorized excavation consists of removal of materials beyond

- indicated subgrade elevations or neat-line dimensions without written direction by the Authority.
2. Unauthorized excavation, as well as remedial work as directed, shall be at Contractor's expense.
 3. Backfill and compact unauthorized excavations as specified for authorized excavations of same classification.
- F. Disposal of Excavated Material:
1. Excavated material that is not suitable for use shall be disposed of at a Contractor furnished disposal area.
 2. Except as otherwise stated, the Contractor shall make their own arrangements and assume all cost in connection with disposal sites. Disposal sites shall be located and maintained in such a manner as to prevent a public nuisance.
 3. If the disposal site is located on private land, the Contractor shall obtain written permission from the property owner or owners for such disposal sites and shall furnish the Authority with a copy of this permission. The written permission shall specifically provide that the property owner will not hold the Authority, its employees, agents, or engineers liable for use or damage to this property. The Contractor shall be liable for any trespass and property damage incurred as a result of utilizing the disposal site.

3.3 SITE PREPARATION

- A. Clear and grub the construction area in accordance with Section 31 11 00 of the Specifications and the Drawings. Remove and dispose all organic material, silt, and top soil.
- B. Project area must be fully thawed (no seasonal frost) prior to placement of fill. If frozen soils are encountered, promptly notify the Authority. At the discretion of the Authority, additional time shall be allowed for the ground to thaw.
- C. Fill all depressions or holes below the general area surface level, whether caused by removal of debris or unacceptable material, or otherwise. Fill with Classified material as shown on the drawings, and compact to specified density and to a level, uniform surface before the placement of subsequent layers.
- D. Sloped ground surfaces steeper than 1 vertical to 4 horizontal on which embankment is to be placed shall be plowed, benched, or broken up in such manner that the fill material will bond with the prepared surface.

3.4 EMBANKMENT CONSTRUCTION

- A. Embankment Fill Placement:
 1. Classified material shall be placed at the locations and to the lines and grades indicated on the Drawings. The material shall be placed and spread uniformly in successive layers not exceeding eight (8) inches in

loose thickness. The layers shall be carried up full width from the bottom of the fill to avoid the necessity of widening the edges after the center has been brought to grade. Each layer shall be compacted in accordance with Paragraph 3.5 of this Specification.

2. Blading, rolling, and tamping shall continue until the surface is smooth, free from waves and irregularities, and conforms to elevations shown on the Drawings. If at any time the material is excessively wet; it shall be aerated by means of blade graders, harrows, or other suitable equipment until the moisture content is satisfactory. The surface shall then be compacted and finished as specified above.
3. Oversized material shall be removed. Portions of any layer in which the embankment material becomes segregated shall be removed and replaced with satisfactory material or shall be added to and remixed to secure proper gradation as directed by the Authority. No separate payment will be made for any material removed or regraded in areas where material becomes segregated.

3.5 COMPACTION

- A. Compact each embankment lift to 95% of maximum density at optimum moisture content as determined by ASTM D1557 or AASHTO T-180, Method D.
- B. Correct improperly compacted areas or lifts until adequate compaction is achieved.
- C. Portions of any lift in which the materials become segregated or unworkable due to pumping/moisture content to the extent that the required percent compaction cannot be attained, shall be removed and replaced with satisfactory materials, or blended with additional material until specified percent compaction is attained.
- D. If, in the opinion of the Authority, based on inspection, subgrade and layers of embankment that have been placed are below specified density, the Contractor shall perform additional compaction and testing at elevations directed by the Authority until specified density is obtained, at no additional cost to the Authority.
- E. The Contractor shall be responsible for providing the proper size and type of compaction equipment and for selecting the proper method of operating said equipment to attain the required compaction density.

3.6 GRADING

- A. Existing ground contours shown on the Drawings are based upon limited survey information and are approximate.
- B. Finished surfaces shall be not more than 0.10 foot above or below the finished grade elevations shown on the Drawings; soft spots or settling areas shall be corrected at Contractor's expense. Feather finish grades to match adjacent existing roads and parking surfaces where required.

3.7 MAINTENANCE

- A. As necessary, Contractor shall water the site while grading is in progress to control dust.
- B. Contractor shall protect newly graded areas from traffic and erosion and keep free of trash and debris.
- C. Contractor shall repair and re-establish grades in settled, eroded and rutted areas as directed by the Authority.
- D. Where completed compacted areas are disturbed by subsequent construction operations or adverse weather, scarify surface, reshape, and compact to required density prior to further construction.
- E. All open excavations shall be adequately signed and barricaded to protect the public.

END OF SECTION

SECTION 31 23 19
DEWATERING AND CONTROL OF SURFACE WATER

PART 1 - GENERAL

1.1 SCOPE OF WORK

- A. This Section describes the requirements for dewatering and the control of surface water during construction.

1.2 SYSTEM DESCRIPTION

- A. Dewatering and temporary diversion works shall be designed by and be the sole responsibility of the Contractor.
- B. Design dewatering systems to:
 - 1. Prevent the pollution of nearby water bodies, including drainage ponds, lakes, and rivers.
 - 2. Prevent damage to adjacent properties, buildings, utilities, and construction operations.
 - 3. Maintain stability of sides and bottoms of excavations.
- C. Locate system components without interfering with installation of permanent Work and existing rights-of-way, buildings, and improvements.

1.3 RELATED REQUIREMENTS

- A. Division 1
- B. Section 31 23 00 - Excavation and Fill

PART 2 - PRODUCTS

2.1 GENERAL

- A. Selection of equipment and materials to perform the work is the responsibility of the Contractor.
- B. The Contractor shall be responsible for preparation of any required Storm Water Pollution Prevention Plan.

2.2 STORM WATER POLLUTION PREVENTION PLAN (SWPPP)

- A. The area of trenching and backfill for buried utilities is approximately 1/6 acre which is less than the 1-acre threshold which requires preparation of a SWPPP.
- B. If Contractor activities exceed the 1-acre threshold, the Contractor shall be responsible for preparation and implementation of the required SWPPP.

PART 3 - EXECUTION

3.1 GENERAL

- A. Contractor shall make their own provisions for diverting surface run off,

- alleviating ponding water, and dewatering excavation when ground water is encountered.
- B. Contractor shall be responsible for coordinating, acquiring, and paying for all permits required for dewatering operations.
 - C. Remove ponded water and limit water flowing or infiltrating into the work area to the extent that the quality of work is not compromised.
 - D. Surface water flows within the work area shall be diverted by constructing temporary ditches, berms, or other means to control and direct the water away from the work; use of pumping equipment may be required to dewater some areas.
 - E. Discharge from dewatering operations shall be returned to natural drainage routes. Settling pits, silt fences, straw dikes, or other appropriate measures shall be taken to prevent highly turbid waters from entering existing ponds, streams, or wetlands.

END OF SECTION

SECTION 31 23 33
TRENCHING AND BACKFILL FOR UTILITIES

PART 1 – GENERAL

1.1 SCOPE OF WORK

- A. The Work under this item includes furnishing all labor, materials and equipment to perform all operations pertaining to trenching and backfill for utilities.
- B. Buried utilities covered includes but is not limited to heat recovery piping. See Sections for each utility for additional requirements.

1.2 RELATED REQUIREMENTS

- A. Section 07 21 00 - Thermal Insulation.
- B. Section 31 23 00 - Excavation and Fill.
- C. Section 31 23 19 - Dewatering and Control of Surface Water.
- D. Section 33 61 14 - PEX Arctic Pipe.

1.3 PROTECTION

- A. Protect personnel and vehicular traffic from trenches and excavations by providing adequate barricades and signage.
- B. Protect excavation side-slopes or adjacent structures by providing adequate back-slopes, shoring, bracing or other methods required to prevent failure of the excavation or existing soils.
- C. Protect all above and belowground utilities.
- D. Notify the Authority of unexpected sub-surface conditions and discontinue work in affected areas until notification is given to resume work.
- E. Grade top perimeter of the excavation to prevent surface water runoff from entering the excavation.
- F. Provide for dewatering of the trench where ground water is encountered.

PART 2 – MATERIALS

2.1 TRENCH BACKFILL

- A. Material for trench backfill shall be obtained from the trench excavation except for bedding material as specified and indicated.
- B. If the excavated material is unsuitable for trench backfill (contains organic matter, muck, peat, frozen materials, vegetation, debris or other unsuitable or deleterious matter) then furnish Classified Fill material.
- C. Bedding shall consist of Pipe Bedding Material (1" minus Classified Fill) as specified in Section 31 23 00.

2.2 LOCATOR/WARNING TAPE

- A. Metallic Locator/Warning tape shall be capable of being inductively detected electronically. Tape shall be as manufactured by Lineguard, Inc., Wheaton, Illinois, (708)-653-0271, Reef Industries, Inc., Houston, Texas, (713)-943-0070, or approved equal. Materials shall conform to the following:
1. Film: Inert plastic. Each film layer shall be not less than 0.0005-inch thick (0.5 mil).
 2. Imprint: 3/4-inch or larger bold black letters.
 3. Legend: The buried utility line tape shall be identified with imprint such as "Caution: Fuel Line Below" and the identification repeated on approximately 24-inch intervals.
 4. Metallic foil laminated between two layers of impervious plastic film not less than 2 inches wide. The adhesive shall be compatible with the foil and film. Total thickness of tape shall not be less than 0.005 inch (5 mil).

PART 3 – EXECUTION

3.1 PREPARATION

- A. Identify all existing underground utilities. Stake and flag their locations.
- B. Maintain and protect the existing utilities that may pass through the work area. The Contractor shall coordinate with UI, the Village, and all other local utility companies before beginning exaction activities.
- C. Existing utilities shown on the Plans are based on incomplete records. Contractor shall coordinate with Local Utilities and have appropriate materials on hand to repair water, sewer, communication, and electrical utility damage that may occur as a result of construction activities. Contractor shall repair damaged utilities at no additional cost to the project.

3.2 EXCAVATION

- A. Excavate the subsoil required for installing piping and conduits.
- B. Cut trenches sufficiently wide to enable proper installation and inspection of utilities as specified and shown on the Drawings.
- C. When excavated material is unsuitable for trench backfill dispose of in accordance with Section 31 23 00 Excavation and Fill.
- D. Correct unauthorized excavation or over-excavated areas at no cost to the Authority.
- E. All trenching depths specified are minimum as measured from the final grade to the top surface of the utility. The trenches shall be dug so that the bottom has a smooth grade. The routing shall be as shown on the Drawings unless conditions encountered are such that changes are necessary to accomplish the work. In such event promptly notify the Authority.

- F. Where trenches are intended for more than one utility, particular care must be taken to provide for extra depth and width to allow for soil falling into the trench during the laying of the first utilities.
- G. Construction shall be arranged so that trenches will be left open for the shortest practical time to avoid creating a hazard to the public and to minimize the likelihood of trench collapse due to other construction activity, rain, accumulation of water in the trench, etc.
- H. Install rigid insulation and buried utility marking tape as shown on the Drawings.

3.4 TRENCH BACKFILL

- A. The first lift is to provide at least a 6 inch bedding thickness over the pipes. Bedding shall consist of 1" minus Pipe Bedding Material as described in Section 31 23 00 Excavation and Fill.
- B. No blocking of any type shall be used to adjust the pipe to grade.
- C. Subsequent lifts of not more than 8-inches shall be installed and individually compacted to 95% of maximum density as described in Section 31 23 00 Excavation and Fill.
- D. Where ground water is present, the Contractor shall provide drainage through pumping or ditching to ensure that the bedding does not become saturated before placement of the backfill material.
- E. The Contractor shall exercise caution when compacting above pipes to ensure that the pipes and coatings are not damaged by compaction and backfilling operations. All pipes or coatings damaged during backfill or compaction operations shall be repaired or replaced by the Contractor, at no expense to the Authority.
- F. Where trenching crosses a road or driveway, the top 12" minimum shall be filled with Classified Fill material as described in Section 31 23 00 Excavation and Fill.

3.5 FIELD QUALITY CONTROL

- A. Provide photographs to the Authority of open excavations, rigid insulation placement, bedding, and utility installation prior to placement of backfill. Any work that is covered without approval may be subject to excavation for inspection at no cost to the Authority.

END OF SECTION

SECTION 33 05 00
COMMON WORK RESULTS FOR UTILITIES

PART 1 – GENERAL

1.1 SCOPE OF WORK

- A. Provide all labor, materials, equipment, and test equipment necessary to furnish, install, and place into operation new buried electrical feeder, overhead electrical distribution system, and heat recovery arctic pipe system as indicated on the drawings, specifications, and staking sheets.
- B. Demolish portions of the existing overhead electrical distribution system as indicated on the Drawings.
- C. Telephone service is not a part of this project except where modifications to the overhead electric distribution requires moving and/or re-attachment of existing telephone lines. In addition, the contractor shall be responsible for repairing any damage to the telephone system resulting from contractor activities.
- D. Where the work of several crafts is involved, coordinate all related work to provide each system in complete and in proper operating order. Cooperate with all others involved in the project, with due regard to their work, to promote rapid completion.
- E. Prior to commencing with the work, the Contractor shall prepare and submit a schedule for the construction activities associated with the installation and startup. The schedule shall identify the routing of the new system and the means to maintain electrical service throughout construction.
- F. Local Conditions: The Contractor shall thoroughly familiarize themselves with the work as well as the local conditions under which the work is to be performed. Schedule work with regard to seasons, weather, climate conditions, and all other local conditions which may affect the progress and quality of work.
- G. The electric utility is the City of Napaskiak, d/b/a Napaskiak Electric Utility, herein after referred to as the electric utility or utility. All construction activity shall be closely coordinated with the utility. The existing electrical distribution system effected by the project serves existing customers. At all times service shall be maintained to the customers except when outages are required for service conversion or other construction related activities. All outages shall be coordinated in advance with the Utility and shall be kept as short as possible.
- H. At certain times, roads or boardwalks will be required to be closed for construction activities will interfere with pedestrian or property owner access. All local requirements for road closing or limited access shall be followed at all times. Any required signs, barricades, or other equipment required for traffic control shall be provided by the Contractor. All activities that limit access to public or private property or right of ways shall be coordinated with the Village Council.

1.2 RELATED REQUIREMENTS

- A. Division 1.
- B. Division 23.
- C. Division 26.
- D. This section applies to all Division 33 work.

1.3 CODES AND STANDARDS

- A. Codes: Perform all work in strict accordance with all applicable national, state, and local codes; including, but not limited to the latest legally enacted editions of the following specifically noted requirements:
 - 1. NFPA 70, National Electric Code – NEC.
 - 2. ANSI-C2, National Electrical Safety Code – NESC.
 - 3. RUS Bulletin 1728F-804, Specifications and Drawings for 12.47/7.2 kV Line Construction.
- B. Standards: Reference to the following standards infers that installation, equipment, and materials shall be within the limits for which it was designed, tested, and approved, in conformance with the current publications and standards of the following organizations:
 - 1. American National Standards Institute – ANSI.
 - 2. American Society for Testing and Materials – ASTM.
 - 3. Factory Mutual – FM.
 - 4. Institute of Electrical and Electronics Consultants – IEEE.
 - 5. National Electrical Contractors Association – NECA.
 - 6. National Electrical Manufacturers' Association – NEMA.
 - 7. National Fire Protection Association – NFPA.
 - 8. Underwriters Laboratory – UL
- C. If the Contractor observes that the Drawings and/or Specifications are at variance with such codes and regulations, he shall promptly notify the Authority in writing.
- D. Should the Contractor perform any work in non-compliance with the above-mentioned codes and regulations without such notice to the Authority, the Contractor shall bear all costs arising therefrom.
- E. The above codes are referenced to establish minimum requirements and wherever this specification requires higher grades of material or workmanship than required by the codes, this specification shall prevail.

1.4 QUALITY ASSURANCE

- A. Division 1 – Quality Control.

- B. Perform all work in accordance with above referenced codes and standards which are referenced to establish minimum requirements.
 - 1. If the Contractor observes that the Drawings and/or Specifications are at variance with such codes and regulations, he shall promptly notify the Authority in writing.
 - 2. Should the Contractor perform any work in non-compliance with the above-mentioned codes and regulations without such notice to the Authority, the Contractor shall bear all costs arising therefrom.
- C. In addition, perform all work in accordance with the specific requirements of all Division 33 sections which follow. Wherever the specifications require higher grades of material or workmanship than required by the codes the specifications shall prevail.
- D. In accordance with Alaska statues and regulations, all Electrical work falling under the scope of 12 AAC 32.075 shall be performed under the supervision of an Electrical Administrator with a current license in the State of Alaska in the Unlimited Linework Category.
- E. All electrical distribution work shall be performed by Alaska licensed Journeyman Electricians or licensed Apprentice Electricians under the direct supervision of a licensed Journeyman Electrician. Journeyman and Apprentice Electricians' current cards shall be available on the project and made available for review upon request.
- F. All pipe welding work shall be performed by an experienced welder with current API or equivalent certification for pipe welding in all positions. Certification shall be available on the project and made available for review upon request.
- G. Perform work with skilled craftsmen specializing in said work. Install all materials in a neat, orderly, and secure fashion, as required by these specifications and commonly recognized standards of good workmanship.
- H. Test all work as required by the specifications. Document all testing and submit results in accordance with specifications.

1.5 SPECIAL CONDITIONS AND REQUIREMENTS

- A. Contactor shall ensure that appropriate safety measures are implemented and that all workers are aware of the potential hazards from electrical shock associated with working on or near energized medium voltage distribution equipment.

1.6 DRAWINGS, SPECIFICATIONS, STAKING SHEETS, & SYMBOLS

- A. The Drawings, Specifications, and Staking Sheets are complementary; what is shown on one is as binding as if called for in both. Do not scale the Drawings. Locations of devices, fixtures, and equipment are approximate unless dimensioned.
- B. The Drawings are partly diagrammatic and do not show precise routing of circuits or exact location of all products, and may not show in minute detail all features of the installation; however, provide all systems complete and in proper operating order.

- C. Drawing symbols used for basic materials, equipment and methods are commonly used by the industry and should be universally understood. Special items are identified by a supplementary list of graphical illustrations, or called for on the Drawings or in the specifications.

1.7 SPECIFIC TERMINOLOGY

- A. Streamlining: In many instances, the products, reference standards, and other itemized specifications have been listed without verbiage. In these cases, it is implied that the Contractor shall provide the products and perform in accordance with the references listed.
- B. "Furnish" means to purchase material as shown and specified, and cart the material to an approved location at the site or elsewhere as noted or agreed to be installed by supporting crafts.
- C. "Install" means to set in place and connect, ready for use and in complete and properly operating finished condition, material that has been furnished.
- D. "Provide" means furnish all products, labor, sub-contracts, and appurtenances required and install to a complete and properly operating, finished condition.
- E. "Accessible" means arranged so that an appropriately dressed man 6-foot 2 inches tall, weighing 250 pounds, may approach the area in question with the tools and products necessary for the work intended, and may then position himself to properly perform the task to be accomplished, without disassembly or damage to the surrounding installation.
- F. "Serviceable" means arranged so that the component or product in question may be properly removed and replaced without disassembly, destruction, or damage to the surrounding installation.
- G. "Product" is a generic term which includes materials, equipment, fixtures, and any physical item used on the project.

1.8 SUBMITTALS – GENERAL REQUIREMENTS

- A. Provide submittals for all products and systems described in Division 33 specifications and/or shown on the Drawings and Staking Sheets to demonstrate compliance with the requirements of the project. Furnish submittals in the manner described herein, and in Division 1 with an index following specification format and with item by item identification.
- B. Submittal review is for general design and arrangement only and does not relieve the Contractor from any of the requirements of the Contract Documents. Submittals will not be checked for quantity, dimension, fit or proper technical design of manufactured equipment. Where deviations of substitute product or system performance have not been specifically noted in the submittal by the Contractor, provision of a complete and satisfactory working installation of equal quality to system specified is the sole responsibility of the Contractor.
- C. Submittals shall demonstrate compliance with the requirements of the project. Furnish all relevant data as appropriate including but not limited to:

1. Manufacturer's name and address, and supplier's name, address, and phone number.
 2. Catalog designation or model number with rough-in data and dimensions.
 3. Operation characteristics.
 4. Complete customized listing of characteristics required. Indicate whether item is "As Specified" or "Proposed Substitution." Indicate any deviations on submittal. Mark out all non-applicable items. The terminology "As Specified" used without this customized listing is not acceptable.
 5. Wiring diagrams for the specific system.
 6. Coordination data to check protective devices.
 7. Shop Drawings.
- D. Provide submittals for all materials in the Division 33 specification sections which follow and submit under that specification section. Data submitted shall demonstrate that these items meet the requirements of the individual specification sections or paragraphs. Items requiring submittals shall include but not be limited to:
1. Electrical Utilities Material and Equipment.
 2. Raceways, Fittings, and Supports.
 3. Conductors, Wire, and Cable.
 4. Sag and tension and stringing tables.
 5. Arctic pipe systems.
 6. Additional items that may be indicated on the Drawings.
- E. Note that transformers will be Owner furnished. The the approved submittals for these items are included in these specifications.

1.9 SUBMITTALS UNDER THIS SECTION

- A. Under this specification section provide submittals for any products and systems shown on the Drawings or Staking Sheets that are not referenced under a Division 33 specification. Identify by the Drawing or Staking Sheet reference.

1.10 COORDINATION

- A. Drawings are partly diagrammatic and it is not the intent to show in detail all features of work or exact physical arrangement of equipment. Equipment shall be located and installed so that it will be readily accessible for operation and maintenance.
- B. If equipment is placed incorrectly with respect to accessibility and required operating clearances, the work affected shall be removed and re-installed at the Contractor's expense.
- C. The Contractor shall schedule his work to coordinate through the General Contractor and with all other subcontractors, power and telephone utilities in order

to maintain job progress and to avoid conflicts with equipment installation or work done by the various trades.

- D. The Contractor is responsible for maintaining required operating clearances. Should the Contractor become aware of operating clearances violation or if the installation of electrical equipment as shown produces an operating clearances violation, notify the Authority in writing before proceeding with the installation.

1.11 DEVICES AND EQUIPMENT

- A. Devices and equipment shall be listed for the intended service. Manufacturers or model numbers shown on the drawings or in the specifications is provided to indicate the required features. Substitutions of equivalent items will be accepted unless items specifically indicate no substitutes.
- B. Install all equipment such that the minimum required operating clearances are maintained.
- C. Protect all materials and equipment during the entire duration of construction work against contamination or damage. Replace or repair to original manufactured condition any items damaged during construction. Immediately report to the Authority any items found damaged prior to commencing construction.

1.12 INSPECTIONS

- A. Provide advance written notice to the Authority in accordance with Section 01 77 00 - Contract Closeout Procedures to schedule substantial completion inspection. The Authority will generate a punch list of corrective action items during the inspection. Work will not be considered complete until all corrective action items in the Authority's punch list have been satisfactorily completed and photographic or other positive documentation has been provided to the Authority.
- B. Cooperate with the Authority and provide assistance at all times for the inspection of the electrical work performed under this Contract. Remove covers, operate machinery, or perform any reasonable work which, in the opinion of the Authority, will be necessary to determine the completeness, quality, or adequacy of the work.

1.13 STAKING SHEETS

- A. Staking sheets are included as part of the Contract Documents. RUS Units referenced have not been included unless the Unit has been modified by this project. Contractor shall obtain copies of the RUS Units and keep them on the jobsite at all times for reference.

1.14 RECORD DRAWINGS & STAKING SHEETS

- A. Reference requirements stated in Division 1.
- B. In addition to other requirements, mark up a clean set of Drawings and Staking Sheets as the work progresses, to show the dimensioned location and routing of all electrical work which will become permanently concealed. Show complete routing and sizing of any significant revisions to the systems shown.

- C. Maintain Record Drawings and Staking Sheets in an up-to-date fashion in conjunction with the actual progress of installation. "Record" progress mark-ups shall be available on-site for examination by the Authority at all times.
- D. Prior to substantial completion, deliver these drawings and staking sheets and their electronic files in both .dwg and full size .pdf format to the Authority and obtain a written receipt.

1.15 PROJECT COMPLETION AND DEMONSTRATION

- A. Division 1 - Closeout Requirements.
- B. The Contractor shall balance the load on the electrical distribution system to the greatest extent possible. Balance shall be read on the bus meter at the power plant. The Contractor shall coordinate balancing with the Utility staff.
- C. Demonstrate installation to operate satisfactorily in accordance with requirements of Contract Documents. Should a portion of installation fail to meet requirements of Contract Documents, repair or replace items until compliance is attained.
- D. Have instruments available for measuring voltage and current values and for demonstration of continuity, ground, or open circuit conditions. Furnish personnel to assist in taking measurements and making tests.
- E. In the event that systems are not complete and fully operational at the time of Final Inspection, all costs of any subsequent inspections shall be borne by the Contractor at no additional cost to the Authority.

1.16 TESTS

- A. Division 1 - Closeout Requirements.
- B. The Contractor shall provide notification to the Authority a minimum of seven (7) calendar days in advance of performing tests. The Authority shall have the right to observe tests. Any tests performed without proper notification shall be repeated upon request of the Authority at no cost to the Authority.
- C. The Contractor shall test the overhead distribution system. Minimum overhead distribution system testing shall include Ground Resistance Test, Operating Test, and Sag and Tension Test. See Section 33 71 01 - Overhead Electrical Distribution for testing requirements.
- D. The Contractor shall test the heat recovery system. See Section 23 21 13 - Hydronic Piping for testing requirements.
- E. Report all test results in writing. Where tests disclose problem areas, retest after the defect has been corrected.
- F. Any rework or repair of equipment required during or as a result of the testing shall be done by the Contractor at no additional expense to the Authority.
- G. The Contractor shall duplicate test readings during Substantial Completion Inspection as requested by the Authority.

1.17 DEVICE CALIBRATION REQUIREMENTS

- A. Division 1 – Quality Control.
- B. Division 23.
- C. Calibrate all electrical and electronic measuring devices as indicated on the Drawings and in the Division 33 sections that follow.
- D. Calibrate all mechanical measuring devices as indicated in Division 23.

1.18 SUBSTANTIAL COMPLETION

- A. In accordance with Section 01 77 00 - Contract Closeout Procedures, provide advance written notice to the Authority to schedule substantial completion inspection. Submit all required documents and ensure all conditions have been met.
- B. Provide Authority access to the site. Provide on-site transportation, ladders, lifts, etc. for inspection and testing of the work.
- C. Cooperate with the Authority and provide assistance at all times for the inspection of the electrical work performed under this Contract. Remove covers, operate machinery, or perform any reasonable work which, in the opinion of the Authority, will be necessary to determine the completeness, quality, or adequacy of the work.
- D. Conduct operating tests and demonstrate that all systems operate satisfactorily in accordance with requirements of Contract Documents. Should a portion of installation fail to meet requirements of Contract Documents, repair or replace items failing to meet requirements until items can be demonstrated to comply.
- E. Have instruments available for measuring voltage and current values and for demonstration of continuity, ground, or open circuit conditions. Provide services of qualified technicians familiar with equipment and systems to assist in taking measurements and making tests.
- F. Assist the Authority in instruction of operators on the proper operation and maintenance of all systems and equipment under this contract. Provide services of qualified technicians familiar with each item or system.

1.19 FINAL COMPLETION

- A. In accordance with Section 01 77 00 - Contract Closeout Procedures, provide notification of completion. Submit all required documents and ensure all conditions have been met.

1.20 WARRANTY

- A. In accordance with Section 01 73 00 – Execution Requirements, provide warranties for all systems and equipment.
- B. See Division 33 sections that follow for specific equipment warranty requirements. Wherever the Division 33 specifications have more stringent warranty requirements than Division 1, the Division 33 requirements shall prevail.

PART 2 – MATERIALS

Not used.

PART 3 – EXECUTION

Not used.

END OF SECTION

SECTION 33 61 14
PEX ARCTIC PIPE

PART 1 - GENERAL

1.1 SUMMARY

- A. Pre-insulated arctic pipe system for not to exceed 200F glycol/water service at 90 psi in direct burial installation. Provide press-fit couplings, adapters, sleeves, shells/couplings, end caps, insulation, shrink sleeves, and all other components required for a complete installation. Heat trace and alarm wires are not required. Install all piping in accordance with manufacturer's instructions.

1.2 RELATED REQUIREMENTS

- A. Section 07 21 00 - Thermal Insulation
- B. Section 23 05 00 – Common Work Requirements for Mechanical.
- C. Section 23 21 13 - Hydronic Piping.
- D. Section 31 23 00 - Excavation and Fill.
- E. Section 31 23 33 - Trenching and Backfill For Utilities.
- F. Section 33 61 24 – Steel Arctic Pipe.
- G. Section 33 61 25 – Exterior Insulated Steel Pipe.

1.3 PERFORMANCE REQUIREMENTS

- A. Minimum Working-Pressure Rating: Unless otherwise indicated, minimum pressure requirement is 90 psig.

1.4 REFERENCES

- A. ASTM – American Society for Testing and Materials:
 - 1. ASTM F876 – Standard Specification for Crosslinked Polyethylene (PEX) Tubing.
 - 2. ASTM F877 – Standard Specification for Crosslinked Polyethylene (PEX) Plastic Hot- and Cold-Water Distribution Systems.
 - 3. ASTM F2080 – Standard Specification for Cold-Expansion Fittings with Metal Compression-Sleeves for Cross-Linked Polyethylene (PEX) Pipe.
- B. CSA – Canadian Standards Association:
 - 1. CSA B137.5 – Crosslinked Polyethylene (PEX) Tubing Systems for Pressure Applications.
- C. DIN – German Institute for Standardization (Deutsches Institut für Normung):
 - 1. DIN 4726 – Plastic Piping Used in Warm Water Floor Heating (Warmwasser-Fußbodenheizungen und Heizkörperanbindungen - Rohrleitungen aus Kunststoffen).
- D. ISO – International Organization for Standardization:

1. ISO 9001 – Quality Management Systems – Requirements.
- E. ISO – International Organization for Standardization:
 1. ISO 9001 – Quality Management Systems – Requirements.
- F. PPI – Plastic Pipe Institute
 1. PPI TR-3 – Policies and Procedures for Developing Hydrostatic Design Basis (HDB), Pressure Design Basis (PDB), Strength Design Basis (SDB), and Minimum Required Strength (MRS) Ratings for Thermoplastic Piping Materials or Pipe

1.5 SYSTEM DESCRIPTION

- A. PEX to be designated as PEXa and be manufactured by the high-pressure peroxide (Engel) method.
- B. Provide fittings where required and as indicated on the drawings.

1.6 SUBMITTALS

- A. Provide submittals for all products and systems under this Section in accordance with Section 23 05 00 - Common Work Results for Mechanical and Division 1.
- B. Product Data:
 1. Piping: Submit data on pipe materials, fittings, and accessories. Submit manufacturers catalog information, specifications, and installation instructions.
 2. Joint Kits: Submit manufacturers catalog information, specifications, and installation instructions.
 3. Accessories: Detectable warning tape and other accessories.

1.7 QUALITY ASSURANCE

- A. Division 1 – Quality Control
- B. Install and test products in accordance with manufacturer’s installation instructions, including storage and handling, installing pipe, fittings, and accessories, building entries, field insulation kits, and testing.

1.8 QUALIFICATIONS

- A. Manufacturer: Company specializing in manufacturing products specified in this section.
- B. Installer: Company specializing in performing Work of this section.

1.9 DELIVERY, STORAGE, AND HANDLING

- A. Prior to shipping, install temporary end caps and closures on pipe sections. Maintain in place until installation.
- B. Deliver pipe in banded coils cut to the length required. The coils shall remain strapped or banded while in storage and should not be uncoiled until time of installation.
- C. Inspect materials on site for damage.

- D. Provide covers as required to limit accumulated UV exposure for outer jacket to no more than one year.

1.10 FIELD MEASUREMENTS

- A. Verify field measurements prior to installation.

1.11 WARRANTY

- A. The pipe manufacturer shall warrant the crosslinked polyethylene carrier pipe to be free from defects in material and workmanship for a period of twenty-five (25) years.

PART 2 - PRODUCTS

2.1 GENERAL

- A. Materials shall be new unless otherwise specified. All items of the same type shall be of the same manufacturer.

2.2 CARRIER PIPE

- A. Crosslinked polyethylene (PEX) carrier pipe shall conform to the requirements of one or more of the following: ASTM F876, ISO 15875 or DIN 16892 and/or DIN 16893. PEX carrier pipe shall have a minimum degree of crosslinking of 70% when tested in accordance with ASTM D2765, Method B
- B. Oxygen Diffusion Barrier: Coextruded barrier layer that limits oxygen diffusion through the PEX carrier pipe to less than 0.32 mg/(m²*day) at 40°C temperature, as defined by DIN 4726, shall be applied to the PEX carrier pipe.

2.3 INSULATED PIPE SYSTEM

- A. Provide single carrier pipe, diameter as indicated, with nominal 1.5" thick polyurethane insulation and continuous corrugated seamless polyethylene outer jacket. Foamed in place polyurethane insulation (0.015 btu/hr-ft-f) to completely fill the annular space between the carrier pipe and jacket to create a fully bonded system that will expand and contract as a unit. Rehau Insulpex, Perma-Pipe PEX-Gard, Rovanco Rhinoflex or approved equal.
- B. Tees, elbows, couplings and sleeves to be hot forged brass or cast bronze. Weld end adapters to be carbon steel. All connections to be with press-fit compression fittings except where indicated as welded. Threaded or bolted compression fittings will not be accepted. Rehau, Perma-Pipe, Rovanco or approved equal.
- C. All field joints to be configured for straight press fit connections with straight insulation joints unless specifically indicated otherwise.

2.4 JOINT KITS

- A. Straight joint kits to include polyethylene shells and Canusa HDPE or approved equal shrink casings to form a continuous watertight jacket. Insulation to be flexible closed cell foam sheets or rigid urethane foam half shells. Note that two-part pour-in-place urethane foam will not be accepted.

- B. Provide complete joint insulation kits including all required attachments, heat shrink tape, closure strips, etc. required for installation.
- C. Kits at reducing tees and at PEX to steel connections to allow for outside diameter (O.D.) variations. Any difference in O.D. between pipe, fittings and joint kits must not exceed the allowable shrink tolerance of the supplied heat shrink casing.

2.5 DETECTABLE WARNING TAPE

- A. Minimum 6” wide 5 mil plastic tape laminated to aluminum foil core. Yellow background with black letters “CAUTION BURIED PIPELINE BELOW”. Seton Style No. 85522 or approved equal.

PART 3 - EXECUTION

3.1 EXAMINATION

- A. Prior to installation, inspect interior of pipe for debris and thoroughly clean prior to installation.

3.2 PREPARATION

- A. Cut and prepare ends in accordance with manufacturer’s instructions.
- B. Keep open ends of pipe free from debris and dirt. Protect open ends with temporary plugs or caps.

3.3 EXCAVATION AND BACKFILL

- A. Perform all excavation, bedding, and backfill in accordance with Section 31 23 33 - Trenching and Backfill For Utilities.
- B. Bury at depth indicated on the Drawings using specified bedding material.
- C. Install continuous rigid insulation over PEX arctic pipe as indicated on the Drawings.
- D. Install detectable warning tape continuous over buried arctic pipe as indicated on the Drawings.

3.4 ARCTIC PIPE INSTALLATION

- A. During installation protect piping systems from entry of foreign materials by temporary covers, completing sections of the Work, and isolating parts of completed system.
- B. After pressure testing install insulation joint kits in accordance with manufacturer’s instructions to create a continuous waterproof casing.
- C. Install piping in a manner that will allow for expansion and contraction and for differential ground movement without stressing pipe, joints, or connected equipment. Install closed cell foam of thickness and length indicated at all locations shown on Drawings. Secure in place with tape prior to backfill.

3.5 PRESSURE TESTING

- A. Pressure test prior to installing joint kits. See Section 23 21 13 - Hydronic Piping.
Provide temporary plugs or fittings as required for testing.

3.6 SYSTEM START-UP

- A. See Section 23 21 13 - Hydronic Piping.

END OF SECTION

SECTION 33 61 24
STEEL ARCTIC PIPE

PART 1 - GENERAL

1.1 SUMMARY

- A. Pre-insulated arctic pipe system for 200F glycol/water service at 90 psi in above grade or direct burial installation. Provide pre-insulated piping, elbows, z-bends, and insulation joint kits, shrink sleeves, and all other components required for a complete installation. Heat trace and alarm wires are not required. Install all piping as indicated in the Drawings.

1.2 RELATED REQUIREMENTS

- A. Section 07 21 00 - Thermal Insulation
- B. Section 23 05 00 – Common Work Requirements for Mechanical.
- C. Section 23 05 29 - Hangers and Supports for Piping and Equipment.
- D. Section 23 21 13 - Hydronic Piping.
- E. Section 31 23 00 - Excavation and Fill.
- F. Section 31 23 33 - Trenching and Backfill For Utilities.
- G. Section 33 61 14 – PEX Arctic Pipe.
- H. Section 33 61 25 – Exterior Insulated Steel Pipe.

1.3 PERFORMANCE REQUIREMENTS

- A. Minimum Working-Pressure Rating: Unless otherwise indicated, minimum pressure requirement is 90 psig.

1.4 REFERENCES

- A. American Society of Mechanical Engineers:
 - 1. ASME B31.1 - Power Piping.
 - 2. ASME B31.9 - Building Services Piping.
 - 3. ASME Section IX - Boiler and Pressure Vessel Code - Welding and Brazing Qualifications.
- B. ASTM International:
 - 1. ASTM A53B - Standard Specification for Pipe, Steel, Black and Hot-Dipped.
- C. American Welding Society:
 - 1. AWS A5.8 - Specification for Filler Metals for Brazing and Braze Welding.
 - 2. AWS D1.1 - Structural Welding Code - Steel.
- D. Manufacturers Standardization Society of the Valve and Fittings Industry:
 - 1. MSS SP 58 - Pipe Hangers and Supports - Materials, Design and Manufacturer.

2. MSS SP 69 - Pipe Hangers and Supports - Selection and Application.

1.5 SYSTEM DESCRIPTION

- A. Provide piping system of material as specified in PART 2.
- B. Provide flanges at locations indicated on the Drawings.
- C. Provide pipe hangers and supports in accordance with Drawings and specifications.

1.6 SUBMITTALS

- A. Provide submittals for all products and systems under this Section in accordance with Section 23 05 00 - Common Work Results for Mechanical and Division 1.
- B. Product Data:
 1. Piping: Submit data on pipe materials, fittings, and accessories. Submit manufacturers catalog information.
 2. Joint Kits: Submit manufacturers catalog information.
 3. Accessories: Closed cell foam and other accessories.
- C. Shop Drawings: Submit shop drawings for fabrication of piping sections and fittings.

1.7 QUALITY ASSURANCE

- A. Division 1 – Quality Control
- B. Perform Work in accordance with ASME B31.9 code for installation of piping systems and ASME Section IX for welding materials and procedures.
- C. Perform pipe welding with experienced welder with current API or equivalent certification for pipe welding in all positions.

1.8 QUALIFICATIONS

- A. Manufacturer: Company specializing in manufacturing products specified in this section.
- B. Installer: Company specializing in performing Work of this section.

1.9 DELIVERY, STORAGE, AND HANDLING

- A. Prior to shipping, install temporary end caps and closures on pipe sections. Maintain in place until installation.
- B. Inspect materials on site for damage.

1.10 FIELD MEASUREMENTS

- A. Verify field measurements prior to fabrication.

PART 2 - PRODUCTS

2.1 GENERAL

- A. Materials shall be new unless otherwise specified. All items of the same type shall be of the same manufacturer.

2.2 CARRIER PIPE

- A. Carbon steel pipe, ASTM A53B, ERW or ASTM A106B, schedule 40 unless specifically indicated otherwise.
- B. Carbon steel elbows and tees pipe, ASTM A234 seamless butt weld fittings, standard bore unless specifically indicated otherwise.

2.3 INSULATED PIPE SYSTEM

- A. Provide single carrier pipe, diameter as indicated, with nominal 1.5" thick polyurethane insulation and continuous smooth HDPE outer jacket. Foamed in place polyurethane insulation (0.015 btu/hr-ft-f) to completely fill the annular space between the carrier pipe and jacket to create a fully bonded system that will expand and contract as a unit. Perma-Pipe Xtru-Therm, Rovanco, Thermacor Ferro-Therm, or approved equal.
- B. Pre-fabricated elbows and Z-bends to be equivalent construction to straight pipe using ASTM A234 seamless carbon steel butt weld fittings. Standard elbows and tees to have nominal 3' long tangents or as indicated on Drawings.
- C. Make custom fabrications in accordance with details on the Drawings.
- D. All field joints to be configured for straight butt welds with straight insulation joints unless specifically indicated otherwise.

2.4 JOINT KITS

- A. Straight joint kits to include polyethylene shells and Canusa HDPE or approved equal shrink casings to form a continuous watertight jacket. Insulation to be flexible closed cell foam sheets or rigid urethane foam half shells. Note that two-part pour-in-place urethane foam will not be accepted.
- B. Provide complete joint insulation kits including all required attachments, heat shrink tape, closure strips, etc. required for installation.
- C. Kits at reducing tees and at PEX to steel connections to allow for outside diameter (O.D.) variations. Any difference in O.D. between pipe, fittings and joint kits must not exceed the allowable shrink tolerance of the supplied heat shrink casing.

2.5 CLOSED CELL FOAM

- A. Flexible, closed cell, elastomeric nitrile rubber insulation with a polymeric coating suitable for direct bury application. Armaflex Tuffcoat or approved equal.

PART 3 - EXECUTION

3.1 EXAMINATION

- A. Prior to installation, inspect interior of pipe for debris and thoroughly clean prior to installation.

3.2 PREPARATION

- A. Clean joints and bevel ends before assembly and welding.

3.3 EXCAVATION AND BACKFILL

- A. Perform all excavation, bedding, and backfill in accordance with Section 31 23 33 - Trenching and Backfill For Utilities.
- B. Bury at depth indicated on the Drawings using specified bedding material.

3.4 ARCTIC PIPE INSTALLATION

- A. During installation protect piping systems from entry of foreign materials by temporary covers, completing sections of the Work, and isolating parts of completed system.
- B. After pressure testing install insulation joint kits in accordance with manufacturer's instructions to create a continuous waterproof casing.
- C. Install piping in a manner that will allow for expansion and contraction and for differential ground movement without stressing pipe, joints, or connected equipment. Install closed cell foam of thickness and length indicated at all locations shown on Drawings. Secure in place with tape prior to backfill.

3.5 PRESSURE TESTING

- A. Pressure test prior to installing joint kits. See Section 23 21 13 - Hydronic Piping. Provide temporary blind flanges or welded caps as required for testing.

3.6 SYSTEM START-UP

- A. See Section 23 21 13 - Hydronic Piping.

END OF SECTION

SECTION 33 61 25
EXTERIOR INSULATED STEEL PIPE

PART 1 - GENERAL

1.1 SUMMARY

- A. Scope: This section applies to all exterior insulated hydronic (heat recovery) piping installed above grade underneath buildings.
- B. Section includes:
 - 1. Heat recovery pipe and fittings.
 - 2. Pipe insulation and jackets.

1.2 RELATED REQUIREMENTS

- A. Section 23 05 00 - Common Work Requirements for Mechanical.
- B. Section 23 05 29 - Hangers and Supports for Piping and Equipment.
- C. Section 23 21 13 - Hydronic Piping.
- D. Section 33 61 14 - PEX Arctic Pipe.
- E. Section 33 61 24 - Steel Arctic Pipe.

1.3 REFERENCES

- A. American Society of Mechanical Engineers:
 - 1. ASME B31.1 - Power Piping.
 - 2. ASME B31.9 - Building Services Piping.
 - 3. ASME B16.5 Flanges and Flanged Fittings
 - 4. ASME B16.9 Factory-Made Wrought Steel Butt welding Fittings
 - 5. ASME B16.11 Forged Fittings, Socket-Welding and Threaded
 - 6. ASME Section IX - Boiler and Pressure Vessel Code - Welding and Brazing Qualifications.
- B. ASTM International:
 - 1. ASTM A106B – Standard Specification for Seamless Carbon Steel Pipe for High Temperature Services.
 - 2. ASME B16.11 Forged Fittings, Socket-Welding and Threaded
 - 3. ASTM C585 - Standard Practice for Inner and Outer Diameters of Rigid Thermal Insulation for Nominal Sizes of Pipe and Tubing (NPS System).
 - 4. ASTM C450 - Standard Practice for Fabrication of Thermal Insulating Fitting Covers for NPS Piping, and Vessel Lagging.

5. ASTM B209 - Standard Specification for Aluminum and Aluminum-Alloy Sheet and Plate.

1.4 SYSTEM DESCRIPTION

- A. Provide piping of material as specified in PART 2.
- B. Provide insulation material as specified in PART 2.
- C. Provide pipe hangers and supports per Drawings and specifications.

1.5 SUBMITTALS

- A. Provide submittals for all products and systems under this Section in accordance with Section 23 05 00 - Common Work Results for Mechanical and Division 1.
- B. Product Data:
 1. Piping: Submit manufacturers catalog information for pipe materials, fittings, and accessories.
 2. Insulation: Submit manufacturers catalog information for insulation, jacket, and accessories including heat shrink tape.
- C. Welder's Certificate: Provide welder's certificate in accordance with Section 23 05 00 – Common Work Requirements for Mechanical.

1.6 QUALITY ASSURANCE

- A. Division 1 – Quality Control
- B. Perform Work in accordance with ASME B31.1 and ASME B31.9 code for installation of piping systems.
- C. Perform pipe welding with experienced welder with current API or equivalent certification for pipe welding in all positions.

1.7 QUALIFICATIONS

- A. Manufacturer: Company specializing in manufacturing products specified in this section.
- B. Installer: Company specializing in performing Work of this section..

1.8 DELIVERY, STORAGE, AND HANDLING

- A. Prior to shipping, install temporary end caps and closures on pipe sections. Maintain in place until installation.
- B. Accept insulation materials on site in original factory packaging, labeled with manufacturer's identification, including product density and thickness.
- C. Protect insulation from weather and construction traffic, dirt, water, chemical, and damage, by storing in original wrapping.
- D. Inspect materials on site for damage.

1.9 FIELD MEASUREMENTS

- A. Verify field measurements prior to fabrication.

PART 2 - PRODUCTS

2.1 GENERAL

- A. Materials shall be new unless otherwise specified. All items of the same type shall be of the same manufacturer.
- B. Pipe shall have welded joints except for threaded connections to equipment and valves as required and shown.
- C. Provide butt weld joints for all pipe 2 inches in diameter and larger and on smaller pipe where specifically indicated on Drawings. Provide socket weld or threaded joints for all piping smaller than 2 inches in diameter unless indicated otherwise.

2.2 PIPE AND FITTINGS

- A. Pipe: ASTM A106B seamless black steel pipe. Schedule 40 for all pipe 2 inches in diameter and larger. Schedule 80 for all piping smaller than 2 inches in diameter.
- B. Fittings: ASTM A234 seamless carbon steel butt weld fittings for all pipe 2 inches in diameter and larger and on smaller pipe where specifically indicated on Drawings. Provide socket weld or threaded joints for all piping smaller than 2 inches in diameter using ASTM 105, forged steel fittings, minimum 3000 lb.

2.3 INSULATION AND JACKETS

- A. Insulation: TYPE P-1, ASTM C547, 1-1/2" preformed rigid fiberglass pipe insulation. Thermal Conductivity: 0.23 at 75 degrees F. Operating Temperature Range: 0 to 850 degrees F. Vapor Barrier Jacket: ASTM C1136, Type I, factory applied reinforced foil kraft with self-sealing adhesive joints. Jacket Temperature Limit: minus 20 to 150 degrees F. Johns-Manville "Micro-Lok" or approved equal.
- B. ASTM B209 exterior grade aluminum, 0.016 inch thick sheet, embossed finish roll stock for straight pipe. Pre-formed aluminum covers for elbows and tees. Provide wing seal band closures.
- C. Heat Shrink: Mastic lined heat shrink tape. Raychem Flexclad or approved equal.

PART 3 - EXECUTION

3.1 EXAMINATION AND PREPARATION

- A. Check materials for damage that may have occurred during shipment. Repair damaged materials as required or replace with new materials.
- B. Ream pipe ends and remove burrs. Remove scale and dirt, on inside and outside, before assembly.

3.2 INSTALLATION

- A. Route piping in orderly manner and run level to the maximum extent possible.
- B. Install piping to allow for expansion and contraction without stressing pipe, joints, or connected equipment.
- C. Protect piping systems from entry of foreign materials by temporary covers, completing sections of the work, and isolating parts of completed system.
- D. Install pipe hangers and supports in accordance with Section 23 05 29. Touch up all galvanized items in accordance with Section 23 05 00.
- E. Seal wall and floor penetrations as indicated on the Drawings.
- F. Pressure test piping prior to insulating.
- G. Install pipe insulation continuous between arctic pipe risers at each end. Notch tight around hangers and branch connections.
- H. Cover piping insulation with continuous aluminum jackets. Provide longitudinal slip joints with minimum 2 inch laps located on the bottom of the pipe. Overlap circumferential joints 2" minimum. Secure with wing seal bands at each circumferential joint and between joints at 12" on center maximum.
- I. Seal aluminum jacket to HDPE arctic pipe risers with heat shrink tape.

3.3 PRESSURE TESTING

- A. Pressure test prior to installing joint kits. See Section 23 21 13 - Hydronic Piping. Provide temporary blind flanges or welded caps as required for testing.

3.4 SYSTEM START-UP

- A. See Section 23 21 13 - Hydronic Piping.

END OF SECTION

SECTION 33 71 01

OVERHEAD ELECTRICAL DISTRIBUTION

PART 1 - GENERAL

1.1 SCOPE

- A. This Specification describes the minimum acceptable standards for overhead distribution line construction. All construction work shall be done in a thorough and workmanlike manner in accordance with the Drawings, Staking Sheets, specifications, and the standards specified herein.
- B. Any modified RUS Construction Units or any new construction units are included on the detail sheets in the Drawings. Any standard RUS Construction Units referenced on the Drawings or Staking Sheets shall be obtained by the Contractor. The lack of having the correct RUS construction unit drawing will not be acceptable as an excuse for an incorrect installation.
- C. The Drawings, Specifications, and Staking Sheets are complementary; what is shown on one is as binding as if called for in all. Do not scale the drawings. Locations of devices and equipment are approximate unless dimensioned.

1.2 RELATED REQUIREMENTS

- A. Division 1.
- B. Division 26.
- C. All Other Division 33 Specifications.

1.3 CODES AND STANDARDS

- A. Codes: Perform all work in strict accordance with all applicable national, state, and local codes; including, but not limited to the latest legally enacted editions of the following specifically noted requirements:
 - 1. ANSI-C2, National Electrical Safety Code – NESC.
 - 2. RUS Bulletin 1728F-804, Specifications and Drawings for 12.47/7.2 kV Line Construction.

1.4 QUALITY CONTROL

- A. All material shall be Rural Utility Service (RUS) approved and accepted.
- B. All construction work shall be done in a thorough and workman-like manner in accordance with RUS Bulletin 1728F-804, Specifications and Drawings for 12.47/7.2 kV Line Construction, the Staking Sheets, Drawings and Specification, and Construction Drawings. The Contractor shall obtain a copy of these specifications and shall keep them on the jobsite.
- C. This specification supplements the RUS Bulletins identified above. Where there is a conflict, the more stringent condition shall apply. In general, standard RUS construction unit drawings have been used. However, several construction units have been modified. These construction units are included on the Drawings and

have been identified with a modifier and shall be used in lieu of the similar RUS construction unit.

- D. Work shall be performed to the latest adopted Edition of the National Electric Safety Code (NESC) except where local regulations or the specifications or Drawings are more stringent, in which case the specifications and/or Drawings and the local regulations shall govern.

1.5 SUBMITTALS

- A. Shop Drawings and Product Data: Provide in accordance with Section 33 05 00 - Common Work Results for Utilities and Division 1.
- B. In addition to Product Data the Contractor shall submit the sag and tension method to be used and the associated sag tables. See Section 33 71 11.

PART 2 - PRODUCTS

2.1 GENERAL

- A. Products shall conform to the following requirements. Items of the same classification shall be identical including equipment, assemblies, parts, and components.
- B. Material and equipment shall be the standard product of a manufacturer regularly engaged in the manufacturer of the product.

2.2 INSULATORS

- A. All insulators shall meet ANSI C29.
- B. Post or pin insulators shall be ANSI Class 55 rated minimum 15 kV, polymer, tie top. Contractor shall determine neck size for the conductor provided. Preformed Line Products, or approved equal.
- C. Spool insulators shall be polymer, ANSI Class 53. Preformed Line Products, or approved equal.
- D. Deadend insulators shall be 15 kV, ANSI Class DS, fiberglass core, silicone housing. Provide clevis and tongue fittings as required.
- E. Insulators shall be selected to properly accommodate the armor rod installed on the conductor.

2.3 CROSSARMS

- A. Crossarms shall meet the requirements of RUS Spec. No. DT-5B:PE-16 solid wood, distribution type, and a 1/4 inch, 45° chamfer on all top edges. Crossarms shall be full-length pressure treated using a pressure injection method approved by the Western Wood Preserves Institute. Pressure treatment shall be by the pentachlorophenol process in accordance with AWWA C4. Other treatment processes will not be accepted.
- B. Crossarm gains shall meet ANSI C135.33 requirements.
- C. Crossarms shall be 8 feet in length, unless otherwise required by the Contract Documents. Crossarms shall be machined, chamfered, trimmed, and bored for

stud and bolt holes before pressure treatment. Factory drilling shall be provided for pole and brace mounting, for four pin or four vertical line-post insulators, and for four suspension insulators, except where otherwise indicated or required. Drilling shall provide required climbing space and wire clearances. Crossarms shall be straight and free of twists to within 1/10-inch per foot of length. Bend or twist shall be in one direction only. Crossarms shall have a stamp or nameplate indicating manufacturer, year of manufacture, species of wood, and type of treatment, and grade (close grain or dense).

- D. Crossarm braces shall be selected for the crossarm length and shall be full-length pressure treated using a pressure injection method approved by the Western Wood Preserves Institute. Pressure treatment shall be by the pentachlorophenol process in accordance with AWPAC4. Other treatment processes will not be accepted.

2.4 FUSED CUTOUTS

- A. Primary-fuse cutouts shall be 15 kV, 110 kV BIL, 100A loadbreak open type construction, polymer. NEMA B, heavy duty, 10 kA, for crossarm mounting. Open-link cutouts are not acceptable. Fuses shall be the dropout type. Fuse cutouts shall be equipped with combination mounting brackets for cutout and surge arrester, suitable for the indicated installations.
- B. Hubbell Power Systems, or approved equal.

2.5 SURGE ARRESTERS

- A. Surge arresters shall be 7.65 kV, 9 kV duty cycle, distribution class, MOV type requiring no gap adjustment. Hubbell PDV-100, no. 213708, or approved equal.
- B. Surge arresters shall be provided for protection of aerial-to-underground transitions, gang-operated load-interrupter switches, transformers and other indicated equipment.
- C. Surge arresters shall meet NEMA LA1 requirements for the zinc-oxide type and shall be suitable for outdoor installations. Arresters shall be equipped with mounting brackets suitable for the indicated installations.

2.6 POLE LINE HARDWARE

- A. Zinc-coated hardware material shall meet ANSI C135.1, C135.14, C135.17, C135.22, and C135.33 requirements.
- B. Steel hardware material shall meet ASTM A575 and A576 requirements.
- C. All hardware shall be hot-dip galvanized in accordance with ASTM A153.
- D. All curved washers shall be cast ductile iron.

2.7 GROUNDING

- A. All grounding material shall be copper or bronze. Aluminum material shall not be used.
- B. All below grade connections shall be made using the exothermic weld metal method.

2.8 GUY ASSEMBLIES

- A. Guy material shall be minimum 7 strands, 3/8" nominal diameter, Class A zinc-coated-steel extra high-strength meeting ASTM A475 requirements, with a minimum breaking strength not less than 15,400 pounds or as indicated on the Drawings.
- B. Guy assemblies, including insulators and attachments, shall provide a strength exceeding the required guy strength. Thimbles or thimble-eyes shall be provided on anchor points. Guy hook guy attachments shall be Hubbell catalog number GH5N, or approved equal.
- C. Holding capacities for down guys shall be based on a lead angle of 45 degrees as indicated. When field conditions prevent indicated lead angles, anchors shall be placed in other locations as approved by the Authority.
- D. Guy deadends shall be made by using Preformed Line Products Guy-Grip deadend, or approved equal. Deadends shall be selected to equal or exceed the rating of the RUS unit referenced in the Staking Sheets.

2.9 GUY MARKERS

- A. Guy markers shall be full round, 2-inch by 8 feet long, yellow. Markers shall be made of high density polyethylene with ultra-violet light resistance additives to protect the resin and the color from brittleness and fading. Provide vandal resistant type. Securely clamped to the guy at the bottom and top of the marker.

2.10 SPLICES AND DEADENDS

- A. All splices shall be full tension automatic type, Fargo GL406A, or approved equal.
- B. Primary deadends shall be clamp type dead end shoe, Hubbell PG46N, or equal. Deadends shall be full tension rated for the conductor.
- C. Secondary and service conductors shall be deadended using Preformed Line Products service grip deadends, suitable for the conductor provided.

2.11 POLE NUMBERS

Pole numbers shall be 2-inch high aluminum embossed with Roman typeface. Attached to pole with aluminum barbed round head nail. Pole numbers shall match the associated location in the Staking Sheet.

2.12 PRIMARY OVERHEAD CONDUCTORS

- A. All primary conductors shall be bare overhead, Aluminum Conductor Steel Reinforced (ACSR). Conductors shall conform to the following standards.
 - ASTM B230: Aluminum Wire, 1350-H19 for Electrical Purposes
 - ASTM B231: Aluminum Conductors, Concentric-Lay Stranded.
 - ASTM B232: Aluminum Conductors, Concentric-Lay Stranded, Coated Steel Reinforced (ACSR).

- ASTM B498: Zinc Coated (Galvanized) Steel Core for Use in Overhead Electrical Conductors.
- ASTM B500: ASTM Standard Specification for Metallic Coated Stranded Steel Core for Aluminum Conductors, Steel Reinforced (ACSR).
- B. Each primary cable shall be provided in the sizes indicated in the Staking Sheets or on the Drawings. Cables shall be provided based on the standard Code Word for the specific cable size, i.e. #1/0 ACSR shall be Raven.
- C. The conductors shall be capable of withstanding normal handling incident to manufacture, shipment, and field installation without being deformed or abraded. Such handling includes reeling, lifting and movement of full reels, unreeling, pulling through controlled tension stringing equipment, over stringing sheaves, compression fittings and other standard accessories as required.
1. The conductor shall be Class AA stranding in accordance with Table 1 of ASTM B232.
 2. The conductor size and number of wires shall be as specified herein.
 3. The aluminum wire shall be made of 1350-H19 aluminum alloy in accordance with ASTM B230. The minimum average conductivity of the aluminum shall not be less than 61.2% IACS.
 4. The zinc-coated (galvanized) steel core wire (Class A weight coating) shall be in accordance with ASTM B498. The minimum average conductivity of the steel shall not be less than 8% IACS.
 5. The component conductors shall be made with standard right hand lay.
- D. All tension tests shall meet or exceed ASTM B498, B230, and B232. The surface of the conductors shall remain smooth, free from points, sharp edges, abrasions, or other departures from smoothness that would tend to increase radio interference and corona loss. The conductors shall be free from excessive amounts of grease, metal particles, dirt, or other foreign matter. The conductors shall not deform from the cylindrical form nor shall longitudinal smoothness be affected by strand movement when subjected to tension. Conductor components shall be formed so that there is no slack in the outer layer.
- E. Sag and Tension and Stringing Tables.
- The Contractor shall provide a sag table and stringing table for each conductor based on the following information prior to stringing any conductor. All costs associated with these tables shall be included in the cost of the conductor. Contractor shall submit the sag and stringing table for review.
1. Design Conditions:
 - a. NESC Heavy Loading District, 130 mph wind.
 - b. Ruling Span: 160 feet.
 - c. Tension:

- i. Initial Tension: 15% of Conductor Tensile Strength.
 - ii. Final Tension: 25% of Conductor Tensile Strength.
 - iii. Maximum Tension: 50% of Conductor Tensile Strength.
 2. Creep is not a factor.
 3. Stinging table shall provide sag and tensions at spans of 100 feet to 300 feet at a temperature range of -40° F to 100 ° F.
- F. The MANUFACTURER shall use a statistically based quality control sampling and testing plan to assure acceptable quality levels. As a minimum, sampling and testing shall be as required by ASTM B230, ASTM B232, and ASTM B498.
- G. Provide a certificate of compliance, signed by an authorized employee of the MANUFACTURER, that the material shipped meets the requirements of this specification and any supplementary requirements cited in a contract or order under which it was purchased.

2.13 SECONDARY OVERHEAD CONDUCTORS

- A. All secondary conductors shall be overhead service drop, multiplex, aluminum, 600 volt, 75° C rating, polyethylene insulated conductors. For each assembly, provide insulated conductors as indicated and an ACSR concentrically stranded neutral messenger. Conductors shall conform to the following standards.
- B-230: Aluminum Wire, 1350-H19 for Electrical Purposes.
- B-231: Aluminum Conductors, Concentric-Lay-Stranded.
- B-232 Aluminum conductors, Concentric-Lay-Stranded, Coated Steel Reinforced (ACSR).
- B-399: Concentric-Lay-Stranded 6201-T81 Aluminum Alloy Conductors.
- ICEA S-61-402
- B. Each multiplex cable shall be provided in the sizes indicated in the Staking Sheets or on the Drawings. Cables shall be provided based on the standard Code Word for the specific cable. Cables shall be provided as follows:
1. Duplex Conductors:
Cables utilized for lighting or other 120 volt service. Cable shall consist of one insulated conductor and one neutral.
 2. Triplex Conductors:
Cables utilized for single phase service or other uses as indicated on the Drawings. Cable shall consist of two insulated conductors and one neutral ACSR.
 3. Quadruplex Conductors:
Primarily used for three-phase service. Shall be provided with three insulated conductors and one neutral ACSR. Conductors shall be marked for easy phase identification.

2.14 SUPPORT BRACKETS AND TRANSFORMER MOUNTS

Support mounts for three-phase transformer installations shall be Aluma-form wing cluster mounts, model 3MW-24-M-L. Cluster mounts shall be suitable for the transformers installed.

PART 3 - EXECUTION

3.1 GENERAL

- A. Materials to be used for construction are designated by one or two lower-case alphabetic characters shown on the Drawings and in the "ITEM" column in the drawing material blocks. For example, "b" designates a steel, pole top pin.
- B. Normally crossarm pins and post-type insulators come equipped with washers and locknuts. Thus, the washers and locknuts for crossarm pins are not tallied in the "QTY" (quantity) columns in the material boxes on the Drawings. However, the crossarm pin washers and locknuts are shown on the Drawings in parenthesis to depict proper construction. If crossarm pins or post type insulators are purchased without washers, locknuts or studs, the quantity totals in the material boxes on the Drawings will need to be adjusted accordingly.
- C. Locknuts shall be installed on all threaded material and hardware in addition to nuts and washers. The threads on installed bolts shall protrude past the lock washers a minimum of one inch but not more than two inches.

3.2 DISTRIBUTING POLES

In distributing the poles, large, choice, close-grained poles shall be used for transformers, deadend, angle, and corner poles.

3.3 SETTING POLES

- A. All poles shall be direct buried. Poles shall be buried greater than RUS standards as indicated on the Drawings.
- B. On sloping ground, the depth of the hole shall be measured from the low side of the hole.
- C. Pole backfill shall be thoroughly tamped the full depth. Excess dirt shall be banked around the pole.
- D. Poles shall be set so that alternate crossarm gains face in opposite directions, except at terminals and deadends where the gains of the last two (2) poles shall be on the side facing the terminal or deadend. On unusually long spans, the poles shall be set so that the crossarm comes on the side of the pole away from the long span. Where pole top pins are used, they shall be on the opposite side of the pole from the gain, with the flat side against the pole.
- E. Poles shall be set in alignment and plumb except at corners, terminals, angles, junctions, or other points of strain, where they shall be set and raked against the strain so that the conductors shall be in line. Vertical angle structures (A3, B3, C3) shall be offset from centerline by the length of the insulator string hardware, to prevent adjacent poles from leaning into the angle.

- F. Poles shall be raked against the conductor strain not less than one inch for each ten feet of pole length, but not more than two inches for each ten feet of pole length after conductors are installed at the required tension.
- G. Pole backfill shall be thoroughly tamped the full depth. Excess dirt shall be banked around the pole.

3.4 OVERHEAD CONDUCTOR INSTALLATION

- A. Conductors shall be handled with care. Conductors shall not be tramped on nor run over by vehicles. Each reel shall be examined and the wire shall be inspected for cuts, kinks, or other injuries. Injured portions shall be cut out and the conductors spliced. The conductors shall be pulled over suitable rollers or stringing blocks properly mounted on pole or crossarm if necessary to prevent binding while stringing.
- B. The neutral conductor should be maintained on one side of the pole for tangent construction and for angles not exceeding 30°.
- C. With pin-type insulators the conductors shall be tied in the top groove of the insulator on tangent poles and on the side of the insulator away from the strain at angles. Pin-type insulators shall be tight on the pins and on tangent construction the top groove shall be in line with the conductors after tying in.
- D. For neutral and secondary conductors on poles, insulated brackets (Material Item 'da') may be substituted for the single and double upset bolts on angles of 0° to 5° in locations known to be subject to considerable conductor vibration. All conductors shall be cleaned thoroughly by wire brushing before splicing or the installation of a connector or clamp. A suitable inhibitor shall be used before splicing or applying connectors over aluminum conductor.

3.5 PHASING

- A. New conductors shall follow the same phase arrangement as the existing system.

3.6 SAGGING CONDUCTORS

- B. Conductors shall be sagged evenly and in accordance with the conductor manufacturers' recommendations. The air temperature at the time and place of sagging shall be determined by a certified etched glass thermometer.
- C. The sag of all conductors after stringing shall be in accordance with the conductor manufacturers' recommendations, except that a maximum increase of three (3) inches of the specified sag in any span will be acceptable. However, under no circumstances will a decrease in the specified sag be allowed.
- D. The conductor shall be tensioned above the initial sag conditions. After bringing conductor to proper sag, deadends shall be secured within 2 hours. Wire shall be tied to insulators within 48 hours.

3.7 CONDUCTOR TIES

- A. All ties used shall be pre-formed type as manufactured by Preformed Line Products and conductors shall be properly attached to insulators using preformed ties.

- B. Conductor ties shall be selected to properly accommodate the armor rod installed on the conductor.

3.8 GRADING OF LINE

When using high poles to clear obstacles such as buildings, foreign wire crossing, railroads, etc., there shall be no upstrain on pin-type insulators in grading the line each way to lower poles.

3.9 GUYS AND ANCHORS

- A. Guys shall be placed before the conductors are strung and shall be attached to the pole per the Specifications for Overhead Distribution Line Construction.
- B. All anchors shall be as indicated on the Drawings and specified herein.
- C. Guys shall be placed before the conductors are strung and shall be attached to the pole as shown in the Drawings.
- D. All anchors and rods shall be in line with the strain and shall be so installed that approximately six inches of the rod remain out of the ground. In cultivated fields or other locations, as deemed necessary, the projection of the anchor rod above the earth may be increased to a maximum of 12 inches to prevent burial of the rod eye. The backfill of all anchor holes must be thoroughly tamped the full depth.
- E. Guy bonding clamps shall be installed in the eyes of all anchor rods. All guys (primary & secondary) shall be effectively grounded according to REA/RUS specifications. On secondary poles, guys shall be bonded to the secondary neutral.

3.10 POLE LINE HARDWARE

- A. A locknut shall be installed with each nut, eye-nut, or other fastener on all bolts or threaded hardware such as insulator pins, upset bolts, double arming bolts, etc.
- B. Suitable washers shall be installed under boltheads and nuts on wood surfaces and elsewhere as required. Washers used on through-bolts and double-arming bolts shall be approximately 2-1/4 inches square and 3/16 inch thick. The diameter of holes in washers shall be the correct standard size for the bolt on which a washer is used. Square curved washers shall be used for down-guy attachments to pole. Washers for use under heads of carriage-bolts shall be of the proper size to fit over square shanks of bolts. Eye bolts, bolt eyes, eyenuts, strain-load plates, lag screws, guy clamps, fasteners, hooks, shims, and clevises shall be used wherever required to adequately support and protect poles, brackets, crossarms, guy wires, and insulators.
- C. A 3 inch by 3 inch (minimum), square, curved washer (item "d") shall be used abutting the pole when installing primary deadend, neutral deadend and guy assemblies directly to the pole. A 2-1/4 inch (minimum) square washer shall be placed under the shoulder of crossarm insulator pins whose surface area abutting the crossarm is less than 4 square inches.

3.11 SPLICES AND DEADENDS

- A. Conductors shall be spliced and deadended as indicated on the Drawings. There shall be not more than one (1) splice per conductor in any span and splicing sleeves shall be located at least ten (10) feet from the conductor support.
- B. No splices shall be located in grade B crossing spans nor in the adjacent spans.
- C. Splices shall be no closer than 1,000 feet from one another and there shall be no more than three splices per mile in any primary phase or neutral conductor.
- D. Splices shall be installed in accordance with the manufacturer's specifications and recommendations.

3.12 TAPS AND JUMPERS

- A. Jumpers and other leads connected to line conductors shall have sufficient slack to allow free movement of the conductors. Where slack is not indicated, it shall be provided by at least two (2) bends in a vertical plane, or one (1) in a horizontal plane, or the equivalent. In areas where aeolian vibration occurs, special measures to minimize the effects of jumper breaks shall be used as specified.
- B. All aluminum to aluminum connections shall be provided with a Belleville washer.
- C. Jumpers and other leads connected to line conductors shall have sufficient slack to allow free movement of the conductors. Where slack is not shown on the Drawings it will be provided by at least two (2) bends in a vertical plane, or one (1) in a horizontal plane, or the equivalent. In areas where aeolian vibration occurs, special measures to minimize the effects of jumper breaks shall be used as specified.
- D. All leads on equipment such as transformers, etc., shall be a minimum of #4 AWG bare, stranded copper conductors. No. 4 AWG stranded copper conductors shall be used from the primary line to a cutout and from the cutout to the transformer. Provide slack in the jumper to allow for movement in the conductors during windy conditions. Where aluminum jumpers are used, a connection to an unplated bronze terminal shall be made by splicing a short stub of copper to the aluminum jumper using a suitable aluminum compression sleeve.
- E. All primary jumpers shall consist of minimum #2 ACSR, or the size of the conductor, if larger.
- F. Pole tap assemblies shall be framed so that the source is on top and the load (tap) is below.
- G. In no case shall pin-type insulators be installed upside down to carry jumpers.

3.13 HOT LINE CLAMPS AND CONNECTORS

- A. Connectors and hot-line clamps suitable for the purpose shall be installed. On all hot-line clamp installations, the clamp and jumper shall be installed so that they are permanently bonded to the load side of the line, allowing the jumper to be de-energized when the clamp is disconnected.

- B. Hot-line clamps shall be used at single phase transformer connections beneath three-phase primary lines and where single phase primary taps or extends from a three-phase primary line. Where a hot line clamp is used install a stirrup clamp suitable for the conductor.
- C. Stirrups shall be aluminum, bolted with tin plated loop. Hubbell Power type AHLS, or approved equal. Size selected to fit the primary conductor and the hot line clamp.
- D. Connections to the main line shall be made with compression solderless connectors. Connectors to equipment shall be made with compression connectors bolted to the equipment pad. Tools and dies shall be as recommended by the manufacturer. An embossing die code or other standard method shall provide visible indication that a connector has been adequately compressed on the ground wire. Where ground wires are connected to aluminum-composition conductors, specially treated or lined copper-to-aluminum connectors suitable for this purpose shall be utilized.
- E. All conductors shall be cleaned thoroughly by wire brushing before splicing or installing connectors or clamps. A suitable oxidation inhibitor shall be applied before splicing or applying connectors over aluminum conductor.
- F. All insulated secondary to secondary connections shall be made using compression connectors which are already pre-insulated, or parallel groove connectors and plastic covers.
- G. Secondary connections at the polemount transformers shall be made up as indicated on the Drawings. Inhibitor compound shall be used in all mechanical (setscrew) connections.

3.14 ARMOR RODS

- A. Armor rods shall be provided for all ACSR conductors. Armor rods shall be installed at each insulator but will not be required at primary dead-end assemblies if aluminum or aluminum-lined zinc-coated steel clamps are used.
- B. Lengths and methods of fastening armor rods shall be in accordance with the manufacturer's recommendations. All armor rods shall be pre-formed round.
- C. The application of armor rods to the conductor shall be such that the center of the armor rods shall not deviate from the center of the conductor support by more than 2-1/2 inches.

3.15 SECONDARIES AND SERVICE DROPS

- A. Secondary conductors shall be multi-conductor service cable. The conductors shall be sagged in accordance with the manufacturer's recommendations.
- B. Conductors for secondary underbuild on primary lines will be insulated in those instances where prevailing conditions may limit primary span lengths to the extent that covered wires or service cables may be used. Service drops shall be covered wire or service cable.

- C. Secondaries and service drops shall be so installed as not to obstruct climbing space. There shall not be more than one splice per conductor in any span, and splicing sleeves shall be located at least ten feet from the conductor support. Where the same covered conductors or service cables are to be used for the secondary and service drop, they may be installed in one continuous run.
- D. #4 Service drops over 140' in length shall be solidly guyed.
- E. #2 Service drops over 100' in length shall be solidly guyed.
- F. Install a wrap of tape around multi-plex cable at ends, to prevent further unraveling. Where multi-plex cable is open-ended, fold leads back and tape to mainline. Also tape the rough edges of pre-formed grips to protect the insulated leads from abrasion caused by wind vibration.
- G. Secondary cable shall be installed: 16" below existing bare neutral and 4'10" down on poles intended for a future primary tangent or 6'1" down on poles intended for a future primary dead-end.
- H. Where both 240/120 volt 1-phase and a higher voltage (208 or 480 volt) 3-phase secondary are to be installed, the higher voltage circuit shall be attached at least 16" above the lower voltage circuit (up to 4/0 quadruplex over 1/0 triplex, 200' maximum span).

3.16 SERVICES

- A. Service entrance and riser shall be by the customer. Contractor shall install the service drop and make connections to the customer's service entrance conductors at the weatherhead. Contractor shall install service entrance deadend.

3.17 TRANSFORMERS

- A. Polemount transformers shall be installed and grounded according to REA/RUS specifications. Transformers shall have at least two connections from the tank to the multi-grounded neutral conductor.
- B. Insulated trainer brackets (material item "fo") shall be used at pole transformers to secure secondary multiplex cable leads to prevent chafing due to wind movement.
- C. Transformers internally wired for 120 Volt secondary shall be labeled "120V" with reflective tags, 2.5" minimum height.

3.18 CROSSARMS

- A. Crossarms shall be bolted to poles with 5/8-inch through-bolts with square washer with locknut at each end. Bolts shall extend not less than 1/8 inch nor more than 2 inches beyond nuts.
- B. On single crossarm construction, the bolt head shall be installed on the crossarm side of the pole. Single crossarms shall be placed on opposite sides of consecutive poles.
- C. Double crossarms shall be securely held in position as indicated on the RUS Construction Units. Each bolt shall be equipped with square washers with

locknuts. Double crossarms shall be provided at dead-ends, and at angles and corners as indicated, to provide adequate vertical and longitudinal strength.

- D. Tangent Arms and Buck Arms: Tangent arms and buck arms shall be set at right angles to lines for straight runs and for angles 45° and greater. Tangent arms shall bisect angles of turns of less than 45°. Dead-end assemblies shall be used for turns where shown. Buckarms shall be installed, as indicated, at corners and junction poles.

3.19 BRACES

- A. Wood braces shall be used for crossarm supports, unless specified otherwise on the Drawings. Braces shall be Hughes Brothers type 2023 or 2045, size as indicated on the RUS Construction Units, or approved equal.
- B. Braces shall be bolted to arms with 3/8-inch carriage bolts with round or square washers with locknuts between boltheads and crossarms, and secured to poles with 1/2-inch by 4-inch lag screws after crossarms are leveled and aligned.

3.20 GROUNDING

- A. The ground wire shall be secured to the pole with copper coated staples. The staples on the ground wire shall be spaced two (2) feet apart except for a distance of eight (8) feet above the ground and eight (8) feet down from the top of the pole where they shall be six (6) inches apart.
- B. Ground rods shall be driven full length in undisturbed earth in accordance with the Drawings. The top shall be at least 12 inches below the surface of the earth.
- C. All equipment shall have at least two (2) connections from the frame, case or tank to the multi-grounded neutral conductor.
- D. The equipment ground, neutral wires, and lightning-protective equipment shall be interconnected and attached to a common ground wire.
- E. Ground wire sizes shall be not smaller than No. 4 AWG copper. All pole grounds shall be solid.
- F. Surge Arrester Grounding: Surge arresters shall be grounded. Ground resistance for distribution-class arresters shall be not more than 5 ohms. Ground wire connections shall be not less than #4 AWG for distribution arresters.
- G. Unless otherwise indicated, neutral conductors shall be grounded at each transformer. Also, neutral conductors shall be grounded at a point not exceeding every third pole, or as indicated in the Staking Sheets.

3.21 WOOD POLE STORAGE AND HANDLING

- A. Wood poles held in storage for more than 2 weeks shall be stored in accordance with ANSI 05.1. Poles shall be stacked on treated skids, so arranged as to support the poles without producing noticeable distortion to any of the poles and to allow free circulation of air. The height of the piles shall be limited so as to avoid damage to poles on the bottom layers. Poles shall be piled and supported in such a manner that all poles are at least 1 foot above general ground level and any

vegetation growing thereon. No decayed or decaying wood shall be permitted to remain underneath stored poles.

- B. Handling of wood poles shall be in accordance with ANSI 05.1. Poles shall not be dragged along the ground. Cant hooks, pole tongs, or other tools capable of producing indentations of more than 1 inch in depth shall not be used in handling the poles.

3.22 TESTS

- A. The Contractor shall provide notification to the Authority a minimum of seven (7) calendar days in advance of performing tests. The Authority shall have the right to observe tests. Any tests performed without proper notification shall be repeated upon request of the Authority at no cost to the Authority.
- B. Operating Test: After the installation is completed, the Contractor shall conduct an operating test for approval. Equipment shall be demonstrated to operate in accordance with the requirements herein. Verify correct rotation throughout system. Verify voltage at each service. Correct voltage at any service more than 5% above or below the nominal voltage.
- C. Ground-Resistance Measurements: Ground-resistance measurements shall be taken and certified by the Contractor. Certified test results shall be submitted to the Authority prior to energization of the distribution system. No part of the electrical distribution system shall be energized prior to the receipt of written approval from the Authority of the resistance testing of that system's ground rods and grounding systems. Test reports shall indicate the location of the ground point and grounding system and the resistance and the soil conditions at the time the test was performed. Ground-resistance measurements shall be made in normally dry weather with the ground under test isolated from other grounds. The resistance to ground shall be measured using the fall-of-potential method described in IEEE No. 142.
- D. Sag and Tension Test
 - 1. The Authority reserves the right to witness the procedures used for ascertaining that initial stringing sags and tensions are in compliance with requirements for the applicable loading district and cable weight.
 - 2. The Contractor shall submit the sag and tension method to be used and the sag tables used to achieve the proper sag. The contractor shall wait a minimum of 2 hours after stringing the conductors to allow the conductors to stabilize prior to conducting the sag and tension tests. The contractor must complete the tests within 36 hours after stringing the conductors to avoid damaging the cable. Sagging operations shall not be conducted when wind conditions prevent satisfactory sagging.
 - 3. The span used to set the sag shall be called the sag-check span. The sag-check span shall be a level span and approximately equal to the ruling span.

END OF SECTION

SECTION 33 71 16
WOOD ELECTRICAL UTILITY POLES

PART 1 - GENERAL

1.1 SCOPE

This specification describes the minimum acceptable quality of wood poles. Where there is conflict between this specification and any other specification referred to herein, this specification shall govern. The poles shall be constructed in accordance with these specifications.

1.2 RELATED REQUIREMENTS

- A. Section 33 71 00 - Electrical Utilities

1.3 STANDARDS

All characteristics, definitions, and terminology, except as specifically covered in this specification, shall be in accordance with the latest revision of the following standards.

- | | |
|-------------------------|---|
| RUS Bulletin 1728F-700: | Specification for Wood Poles, Stubs, and Anchor Logs. |
| ANSI 05.1 | Wood Poles - Specifications and Dimensions. |
| AWPA-C4: | Poles - Preservative Treatment by Pressure Processes, American Wood Preservers Association. |

1.4 SUBMITTALS

- A. Shop Drawings and Product Data: Provide in accordance with Section 33 05 00 - Common Work Results for Utilities and Division 1.

PART 2 – PRODUCTS

2.1 WOOD POLES

- A. Wood poles shall meet the requirements of ANSI 05.1 and shall be Douglas Fir drilled and gained in accordance with RUS W1.1G Pole Framing Guide. Wood poles shall have pole markings located 10 feet from pole butts. Other locations will not be acceptable. Poles shall be machine trimmed by turning smooth full length, and shall be roofed, gained, and bored prior to pressure treatment. No climbing rungs shall be provided.
- B. Poles shall be full length pressure treated using a pressure injection method approved by the Western Wood Preserves Institute that prevents leaching. Pressure treatment shall be by the pentachlorophenol process in accordance with AWPA C4. Other treatment processes will not be accepted.
- C. Poles exhibiting any of the following defects will not be accepted; cross-breaks (horizontal cracks), catface (scars), compound through checks, decay, double sweep (poles having sweep in two planes), hollow butts or tops, improper framing, plugged holes (other than increment core holes), spike knots or any knot with bark inclusion, and split top.

- D. Checks:
1. Checks (vertical cracks) are permitted in the top of pole except for any check more than 1/8 inch wide and extending down from the top of the pole more than 12 inches and within 30 angular degrees from the axis of the face of pole directly above ground; and any through checks or splits.
 2. Through checks or splits in the butt surface of the pole are not permitted.
 3. A check is considered to be continuous if it is not separated by at least 1/2 inch of wood. The maximum allowable width and length of any single check are found in Table II "Maximum Allowable Check Dimensions".

TABLE II. MAXIMUM ALLOWABLE CHECK DIMENSIONS

LENGTH OF POLE	MAXIMUM WIDTH	MAXIMUM LENGTH
30 feet	1/4 inch	5 inches
35 and 45 feet	5/16 inch	5 inches
50 feet and longer	3/8 inch	8 inches

- E. Knots:
1. The diameter of any single knot or sum of the diameters of all knots shall not exceed the limits of Table II "Limits of Knot Sizes".

PART 3 – EXECUTION

3.1 CERTIFICATION

- A. Provide a certificate of compliance, signed by an authorized employee of the producer, that the material shipped meets the requirements of this specification and any supplementary requirements cited in a contract or order under which it was purchased.
- B. Provide independent inspection certification.

END OF SECTION

SECTION 33 73 14

OVERHEAD LIQUID-FILLED TRANSFORMERS

Notes:

- 1) *The overhead transformers are Owner Furnished in accordance with Section 01 64 00 - Receipt of Owner Furnished Materials. This Section was used in the purchase of the transformers and is included here for informational purposes.*
- 2) *The submittals for the Owner Furnished transformers are included at the end of this Section.*

PART 1 - GENERAL

1.1 SUMMARY

- A. This specification covers the electrical and mechanical characteristics of Single-Phase Overhead-Type Distribution Transformers. The transformers shall be designed and constructed in accordance with these specifications. All characteristics, voltage designations and tests shall be in accordance with the latest editions of ANSI Standards C57.12.26 and C57.12.00, except as modified herein.
- B. Transformers shall be designed in accordance with RUS requirements and shall be of new construction.
- C. The transformers will be non-evaluated units but shall be provided with minimum efficiencies as specified herein.
- D. Transformers shall be suitable for step-down service or step-up service as indicated in the Bid Schedule.
- E. Quantities and ratings shall be as indicated in the Bid Schedule.

1.2 RELATED REQUIREMENTS

- A. Section 26 05 00 - Common Work Results for Electrical.
- B. Section 33 71 01 - Overhead Electrical Distribution.

1.3 STANDARDS

All characteristics, definitions, and terminology, except as specifically covered in this specification, shall be in accordance with the latest revision of the following ANSI and NEMA standards.

- | | |
|------------|--|
| C57.12.00: | IEEE Standard General Requirements for Liquid-Immersed Distribution, Power and Regulating Transformers. |
| C57.12.20: | Overhead-Type Distribution Transformers, 500 KVA and Smaller: High Voltage, 34500 Volts and Below: Low Voltage, 7970/13800Y Volts and Below. |
| C57.12.31 | IEEE Standard for Pole Mounted Equipment–Enclosure Integrity |
| C57.12.35: | Bar Coding for Distribution Transformers. |

- C57.12.90: IEEE Standard Test Code for Liquid-Immersed Distribution, Power, and Regulating Transformers and IEEE Guide for Short-Circuit Testing of Distribution and Power Transformers.
- C57.12.91: Guide for Loading Mineral-Oil-Immersed Overhead and Pad-Mounted Transformers rated 500 kVA and less with 55°C or 65°C average winding rise.
- NEMA TR-1: Transformers, Regulators, and Reactors.
- NEMA TP-1: Guide for Determining Energy Efficiency for Distribution Transformers
- NEMA TP-3: Standard for Labeling of Distribution Transformer Efficiency.
- DOE: 10 CFR Part 431 – Department of Energy – Energy Conservation Program for Commercial Equipment: Distribution Transformers Energy Conservation Standards; Final Rule.
- REA: Bulletin 50-37 (D10), Specification for Rural Distribution Transformers (Overhead.)

1.4 SUBMITTALS

- A. Shop Drawings and Product Data: Provide in accordance with Section 33 05 00 - Common Work Results for Utilities and Division 1.
- B. Submit complete electrical data, mechanical and layout drawings, and wiring and connection diagrams for each type of transformer provided.
- C. Drawings shall indicate the kVA rating, dimensions, transformer impedance, voltage (both primary and secondary), phase of the transformer, and winding connecting.
- D. Provide certified test reports prior to shipment of the transformers. Test reports shall indicate the impedance, no load, and full load loss of each transformer, by serial number, and shall include the transformer efficiency, expressed in percent, of the transformer based on the test procedures specified herein.
- E. Certified test reports shall contain a statement identifying the amount of PCB in the insulating oil.

1.5 WARRANTY

The failure of any transformer due to defective design, material and/or workmanship within 12 months after being energized or eighteen months after being delivered, whichever comes first, shall be repaired or replaced without cost. Any defect in design, material and/or construction discovered within this period shall be corrected at the manufacturer's expense, either by repair or replacement.

PART 2 - PRODUCTS

2.1 RATINGS

- A. General:
1. Primary System Voltage Rating: 12470/7200 volt, grounded wye.

- | | | |
|----|---------------------------|--|
| 2. | Secondary Voltage Rating: | As indicated as indicated in the Bid Schedule. |
| 3. | Frequency: | 60 Hz. |
| 4. | Phase: | Single. |
| 5. | Impedance: | ANSI Standard. |
| 6. | kVA Rating: | As indicated as indicated in the Bid Schedule. |
| 7. | BIL Rating: 7200/12470Y | 95 kV. |
| 8. | Temperature Rating: | Self-cooled, 65° C above a 30° C ambient. |

2.2 ACCEPTABLE MANUFACTURERS

Acceptable manufactures shall be as follows. Manufacturers shall be on the RUS approved list.

- A. ABB.
- B. Cooper Power.
- C. Ermco.
- D. G. E. Prolec.
- E. Howard Transformers.
- F. Approved equal.

2.3 TRANSFORMER VOLTAGES

- A. Transformer primary voltage shall be 7,200 volts.
- B. Unless otherwise indicated in the Bid Schedule, transformer secondary voltages shall be as follows:
 - 1. Transformers used for single-phase service shall be provided with a secondary voltage of 120/240 volt, single-phase, 3-wire utilizing the full transformer capacity.
 - 2. Transformers used as part of a three-phase transformer bank shall be rated 277 volts to provide utilization of the full transformer capacity for 480/277 volt, three-phase, 4-wire service.

2.4 TRANSFORMER LOSSES

Transformer no load and load losses shall be provided with the transformer submittal and shall be guaranteed by the manufacturer. Transformer losses determined by the factory tests on the individual transformers shall be less than 10% greater than the guaranteed bid losses. No individual unit shall be shipped that exceeds guaranteed no load losses by more than 10%.

2.5 TRANSFORMER TAPS

Transformers shall be furnished with full capacity high-voltage taps. The taps shall be +/-2 - 2½% above and below rated nominal voltage. The tap changer switch shall be an

externally operated switch with a hotstick-operable handle. The tap changer shall be clearly labeled to reflect that the transformer must be de-energized before operating the tap changer as required in IEEE Standard C57.12.20.

2.6 HIGH VOLTAGE BUSHINGS AND TERMINALS

- A. Provide two high voltage bushings. Single bushing transformers will not be acceptable.
- B. The bushing terminals provided shall be tin-plated to accommodate both aluminum and copper conductors. The size of the terminals shall be 5/8”.
- C. The color of the bushings shall match Light Gray Number 70, Munsell Notation 5BG7.0/0.4.
- D. High voltage bushings shall be porcelain.
- E. Provide high voltage bushings rated at 110 or 125 kV BIL.

2.7 LOW VOLTAGE BUSHINGS AND TERMINALS

- A. Low voltage bushings shall be provided with the following ratings.
 - 1. 30 kV BIL Rating.
 - 2. 10 kV 60 Hz Dry 1-Minute Withstand Voltage.
 - 3. 6 kV 60 Hz Wet 10 Second Withstand Voltage.
- B. The bushing terminals provided shall be clamp type to accommodate the use of screw bar post connector.
- C. Provide three porcelain bushings on 120/240 volt transformers.
- D. Provide two porcelain bushings on 277 volt transformers used for three-phase service.
- E. The internal secondary leads shall be permanently embossed with the letters A, B, C, and D per ANSI C57.12.00 and C57.12.20.

2.8 PROTECTION

- A. No overcurrent protection is required. Transformers shall be protected using external fused cutouts installed by others.

2.9 CORE AND COIL

- A. Windings shall be copper or aluminum. All windings shall meet the guaranteed temperature rise requirements.
- B. The core and coil shall be vacuum processed to ensure maximum penetration of insulating fluid into the coil insulation system. While under vacuum the transformer shall be filled with preheated filtered degassed insulating fluid. The core shall be manufactured from burr-free, grain-oriented silicon steel and shall be precisely stacked to eliminate gaps in the corner joints. The coil shall be insulated with B-stage, epoxy coated, diamond pattern, insulating paper, which shall be thermally cured under pressure to ensure proper bonding of conductor and paper.

2.10 TANK

- A. The tank shall include a pressure relief device as a means to relieve pressure in excess of pressure resulting from normal operation. The venting and sealing characteristics shall be as follows.
 - 1. Cracking Pressure: 10-psig \pm 2 psig.
 - 2. Resealing Pressure: 6-psig minimum.
 - 3. Zero leakage from reseal pressure to -8 psig.
 - 4. Flow at 15 psig: 35 SCFM minimum.
- B. The tank coating shall meet all requirements in ANSI C57.12.31 including.
 - 1. Salt Spray Test.
 - 2. Crosshatch Adhesion Test.
 - 3. Humidity Test.
 - 4. Impact Test.
 - 5. Oil Resistance Test.
 - 6. Ultraviolet Accelerated Weathering Test.
 - 7. Abrasion Resistance - Taber Abraser.
- C. The tank provided shall have a recessed tank bottom which offers protection when sliding over rough surfaces.
- D. The tank shall have an internal mark, which indicates the proper oil level per Section 6.2.3 of ANSI C57.12.20.
- E. Permanently stamped secondary leads.
- F. The tank covering, and cover ring loops shall be stainless steel. All hardware shall be stainless steel. A bronze nut shall also be provided to eliminate corrosion problems and avoid galling. Provide a visible cover ground.
- G. Provide a drain/sampling device.
- H. Provide ground connections accepting #8 AWG solid to #2 AWG stranded. Provide a ground strap between the secondary neutral bushing and the transformer tank.
- I. The tank shall include arrester mounting pads, grounding provisions, ANSI support lugs (hanger brackets) and lift lugs. Hanger brackets shall be single.
- J. The tank color shall be ANSI 70 light gray.

2.11 INSULATING OIL

Transformers shall be provided with highly refined inhibited new mineral oil and meet the minimum requirements as specified in Table 1, "Functional Property Requirements," of ASTM D3487 and ANSI C57.106.

2.12 NOISE

Standard transformer sound level shall not exceed the values as calculated per the latest edition of NEMA Publication TR-1.

2.12 NAMEPLATES & LABELS

- A. Diagrammatic nameplate that conforms to the latest edition of ANSI C57.12.00. Impedance of the transformer shall be included on the nameplate. The nameplate shall be etched and black-filled aluminum or stainless steel. Affix to the enclosure with rivets.
- B. In addition to warning labels, provide a label indicating the transformer kVA rating on the front of the transformer, in minimum 2-1/2" black letters.

PART 3 - EXECUTION

3.1 TESTING AND LOSSES

- A. All units shall be tested for the following:
 - 1. No Load (Core) Losses.
 - 2. Load Losses at 85°C and rated current.
 - 3. Percent Impedance at 85°C and rated current.
 - 4. Excitation current (100% voltage) test.
 - 5. Winding resistance measurement tests.
 - 6. Ratio tests using all tap settings.
 - 7. Polarity and phase relation tests.
 - 8. Induced potential tests.
- B. The manufacturer shall provide certification for all design and other tests listed in Table 17 of ANSI C57.12.00 including verification that the design has passed Short Circuit Criteria per ANSI C57.12.00 and C57.12.90.
- C. One PDF copy of the factory certified test report of each test, in IEEE 1388 format, shall be delivered to the Engineer for review and acceptance prior to shipment of the transformers.

3.2 SHIPPING

- A. Transformers shall be installed on pallets to allow loading and unloading with a forklift.
- B. The transformers shall be packaged to protect them from damage during shipment, handling, and storage.

END OF SECTION

"B" & "C" Dimensions include Arresters & Radiators, if applicable.

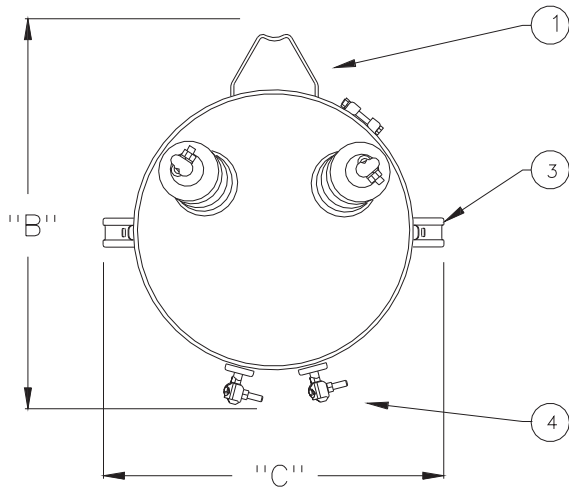

**Note: 3 Each Item #2 167kVA
277/480Y provided as Owner
Furnished step up bank.**

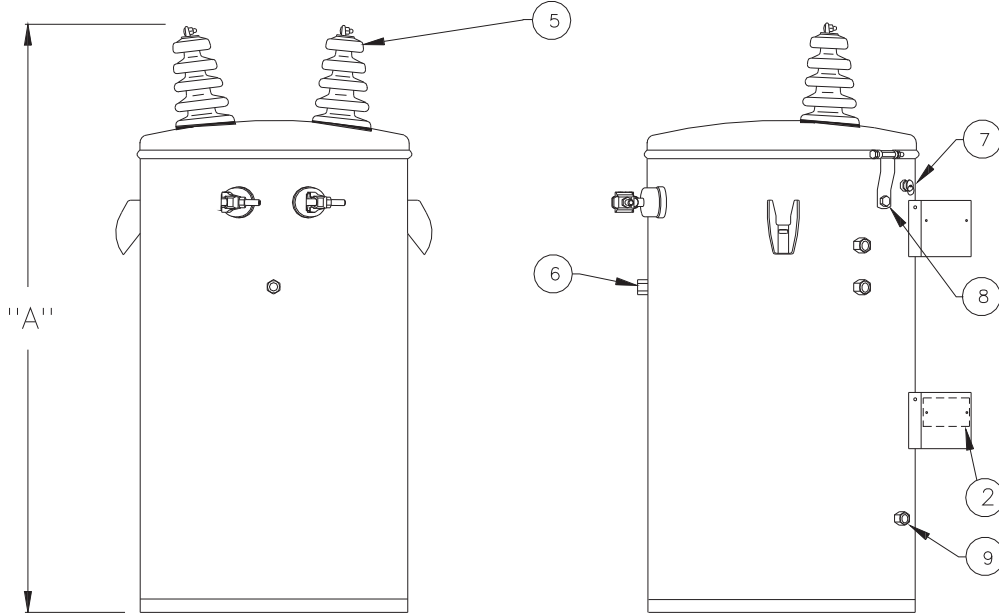

**** UNCONTROLLED ****

H.V. : 7200/12470Y 95BIL 2BU CSP CONV

L.V. : 277/480Y 2 LVBU 30 BIL

TAPS: 2 TAPS 2.5% ABOVE AND BELOW

PART	DESCRIPTION	QUANTITY
1	HANGER BRACKET TYPE: B	1 SET
2	NAMEPLATE (ON LOWER BRACKET) TYPE: (1) ALUMINUM NAMEPLATE (STANDARD)	1
3	LIFTING LUGS	2
4	LOW VOLTAGE BUSHINGS TYPE: 4 HOLE PORCELAIN H-SPADE	2
5	HIGH VOLTAGE BUSHINGS TYPE: EXTRA CREEP HV BUSHING	2
6	GROUNDING PROVISION: W/ GROUND STRAP (S)	1
7	P.R.V.: GENERIC.25 10PSI35SCFM (-01 OR -30)	1
8	COVER GROUND STRAP	1
9	TANK GROUNDING PROVISIONS: W/ (2) GROUND LUGS	2

ADDITIONAL FEATURES
TAP SW: STANDARD DV &/OR TC, HOOKSTICK
KVA DECAL: STANDARD 2.5 BLAKONWHITE KVA DECAL
Oil TYPE: STD TX MINERAL OIL
TK | CVR: MS | 3kV 304L SS
CVR BAND: 3kV 304L SS

ITEM AND/OR STOCK #	KVA	DIMENSIONS IN INCHES			APPROX. GAL. OIL	APPROX. WEIGHT LBS.
		A	B	C		
2	167	55.2	34.9	28	60.5	1470

ERMCO

CUSTOMER: ALASKA ENERGY AUTHORITY RFQ/SPEC #:

SCALE: NTS DATE: 05/12/22 BY: EAR QUOTE NUMBER: 653374

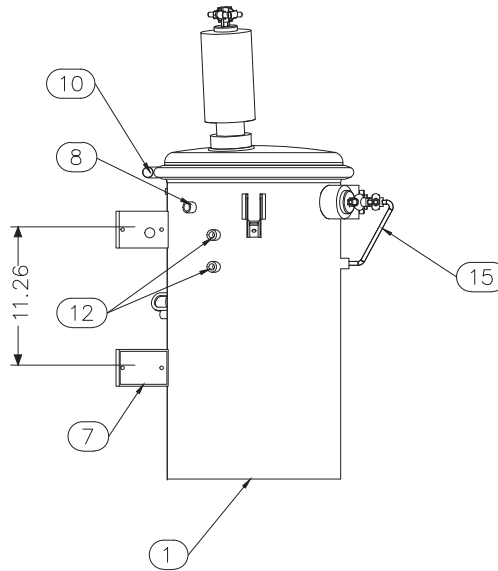
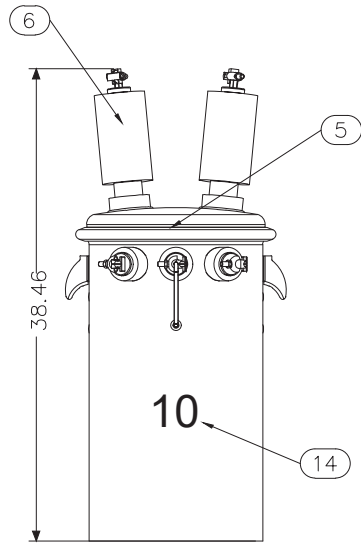
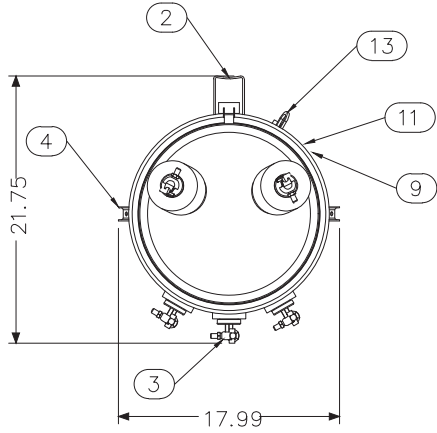



NUM	DESCRIPCION
1	MILD STEEL TANK
2	HANGER BRACKET
3	5/8 EYEBOLT POLYMER LV BUSHING CELECO
4	LIFTING LUGS
5	STAINLESS STEEL COVER & BELT
6	HIGH VOLTAGE BUSHINGS EYEBOLT TYPE TERMINAL H-J ENTERPRISES AS1007-003 #10 - 1#
7	NAMEPLATE
8	FILL PLUG
9	CELECO GROUND CONECTOR #D1090 #8 TO #2/0 AWG
10	GROUNDING DEVICE
11	PRV VIAT #301-010-01N 35 SCFM
12	ARRESTER PROVISIONS
13	ABB TAP CHANGER - 1C11075G03
14	KVA DECAL - 2.75" BLACK LETTERS
15	CU STRAP

NOTE 1: TRANSFORMERS' EXTERIOR COLOR IS GRAY MUNSELL 5BG 7.0/0.4

NOTE 2: FILLED WITH MINERAL OIL PER ASTM TYPE II

For single phase service.

REV 1 - THE CUSTOMER NAME IS UPDATED - MAVL 09/25/2023

Draftman: MAVL	Customer: ALASKA ENERGY AUTHORITY	TOLERANCE: +/- 3%
REV: GLG		
App: LECP	Title: OUTLINE DRAWING 10 KVA, 1 PHASE, 60 HERTZ, 7200/12470Y-120/240 VOLT	
Scale: NONE		
Dimensions in inch		
Date: 09/13/2023	 	Drawing No. AOS884
Rev: 1		

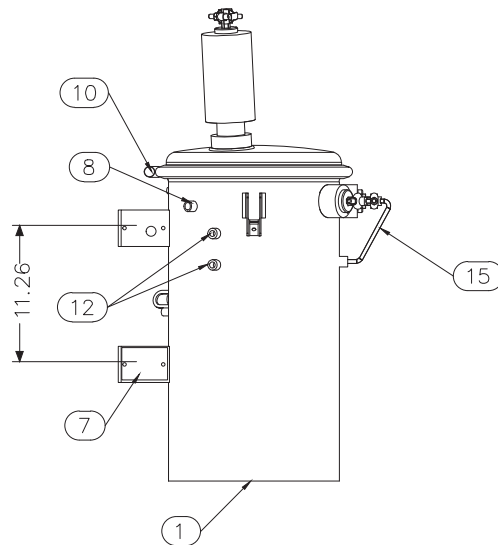
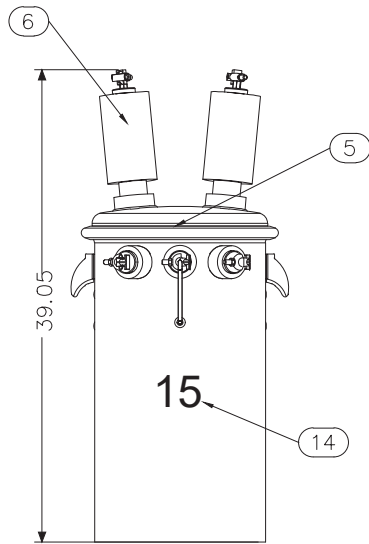
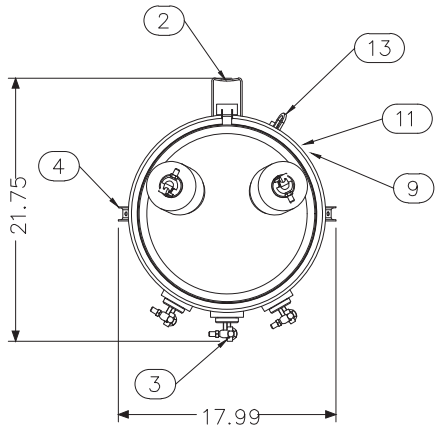



NUM	DESCRIPCION
1	MILD STEEL TANK
2	HANGER BRACKET
3	5/8 EYEBOLT POLYMER LV BUSHING CELECO
4	LIFTING LUGS
5	STAINLESS STEEL COVER & BELT
6	HIGH VOLTAGE BUSHINGS EYEBOLT TYPE TERMINAL H-J ENTERPRISES AS1007-003 #10 - 1#
7	NAMEPLATE
8	FILL PLUG
9	CELECO GROUND CONECTOR #D1090 #8 TO #2/0 AWG
10	GROUNDING DEVICE
11	PRV VIAT #301-010-01N 35 SCFM
12	ARRESTER PROVISIONS
13	ABB TAP CHANGER - 1C11075G03
14	KVA DECAL - 2.75" BLACK LETTERS
15	CU STRAP

NOTE 1: TRANSFORMERS' EXTERIOR COLOR IS GRAY MUNSELL 5BG 7.0/0.4

NOTE 2: FILLED WITH MINERAL OIL PER ASTM TYPE II

For single phase service.

REV 1 - THE CUSTOMER NAME IS UPDATED - MAVL 09/25/2023

Draftman: MAVL	Customer: ALASKA ENERGY AUTHORITY	TOLERANCE: +/- 3%
REV: GLG	Title: OUTLINE DRAWING 15 KVA, 1 PHASE, 60 HERTZ, 7200/12470Y-120/240 VOLT	
App: LECP		
Scale: NONE	 	Drawing No. AOS885
Dimensions in inch		
Date: 09/13/2023		
Rev: 1		

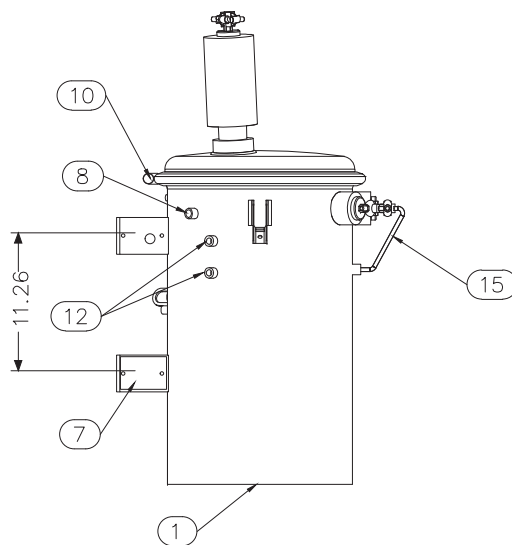
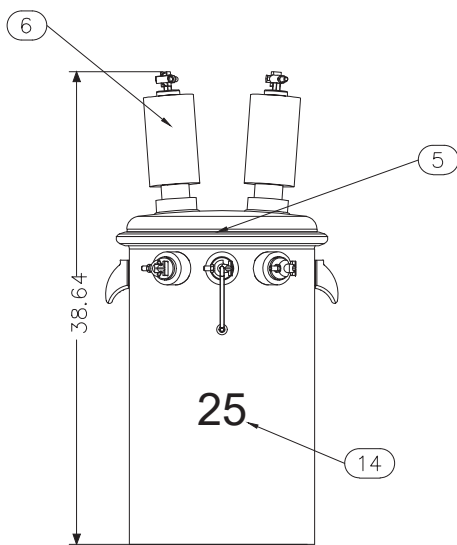
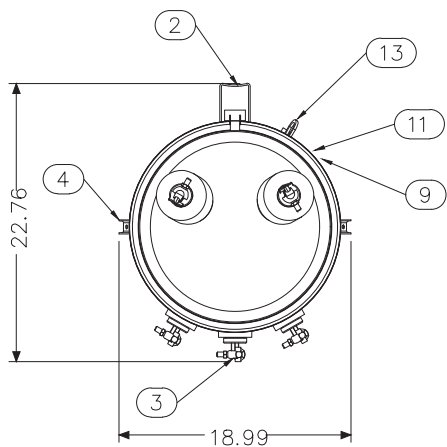



NUM	DESCRIPCION
1	MILD STEEL TANK
2	HANGER BRACKET
3	13/16 EYEBOLT POLYMER LV BUSHING CELECO
4	LIFTING LUGS
5	STAINLESS STEEL COVER & BELT
6	HIGH VOLTAGE BUSHINGS EYEBOLT TYPE TERMINAL H-J ENTERPRISES AS1007-003 #10 - 1#
7	NAMEPLATE
8	FILL PLUG
9	CELECO GROUND CONECTOR #D1090 #8 TO #2/0 AWG
10	GROUNDING DEVICE
11	PRV VIAT #301-010-01N 35 SCFM
12	ARRESTER PROVISIONS
13	ABB TAP CHANGER - 1C11075G03
14	KVA DECAL - 2.75" BLACK LETTERS
15	CU STRAP

NOTE 1: TRANSFORMERS' EXTERIOR COLOR IS GRAY MUNSELL 5BG 7.0/0.4

NOTE 2: FILLED WITH MINERAL OIL PER ASTM TYPE II

For single phase service.

REV 1 - THE CUSTOMER NAME IS UPDATED - MAVL 09/25/2023

Draftman: MAVL	Customer: ALASKA ENERGY AUTHORITY	TOLERANCE: +/- 3%
REV: GLG		
App: LECP	Title: OUTLINE DRAWING 25 KVA, 1 PHASE, 60 HERTZ, 7200/12470Y-120/240 VOLT	
Scale: NONE		
Dimensions in inch		
Date: 09/13/2023	 	Drawing No. AOS886
Rev: 1		

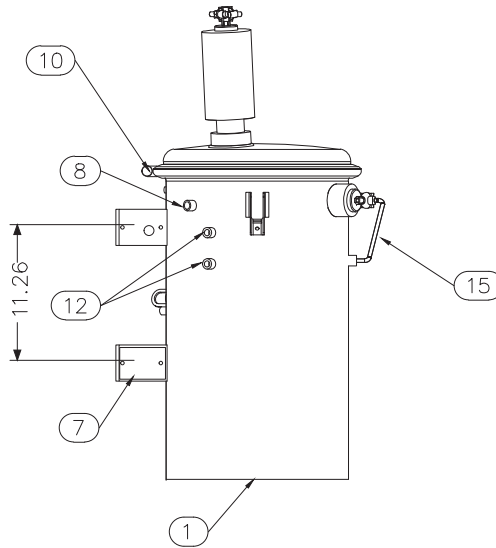
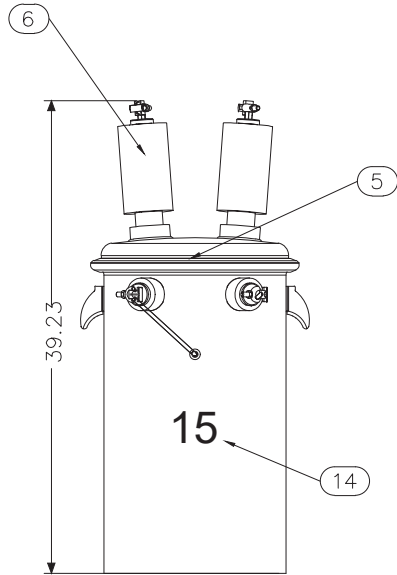
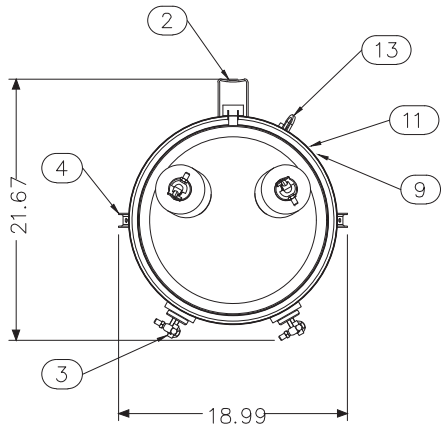



NUM	DESCRIPCION
1	MILD STEEL TANK
2	HANGER BRACKET
3	5/8 EYEBOLT POLYMER LV BUSHING CELECO
4	LIFTING LUGS
5	STAINLESS STEEL COVER & BELT
6	HIGH VOLTAGE BUSHINGS EYEBOLT TYPE TERMINAL H-J ENTERPRISES AS1007-003 #10 - 1#
7	NAMEPLATE
8	FILL PLUG
9	CELECO GROUND CONECTOR #D1090 #8 TO #2/0 AWG
10	GROUNDING DEVICE
11	PRV VIAT #301-010-01N 35 SCFM
12	ARRESTER PROVISIONS
13	ABB TAP CHANGER - 1C11075G03
14	KVA DECAL - 2.75" BLACK LETTERS
15	CU STRAP

NOTE 1: TRANSFORMERS' EXTERIOR COLOR IS GRAY MUNSELL 5BG 7.0/0.4

NOTE 2: FILLED WITH MINERAL OIL PER ASTM TYPE II

For three phase service.

REV 1 - THE CUSTOMER NAME IS UPDATED - MAVL 09/25/2023

Draftman: MAVL	Customer: ALASKA ENERGY AUTHORITY	TOLERANCE: +/- 3%
REV: GLG		
App: LECP	Title: OUTLINE DRAWING 15 KVA, 1 PHASE, 60 HERTZ, 7200/12470Y-120 VOLT	
Scale: NONE		
Dimensions in inch		
Date: 09/13/2023	 	Drawing No. AOS887
Rev: 1		

"B" & "C" Dimensions include Arresters & Radiators, if applicable.

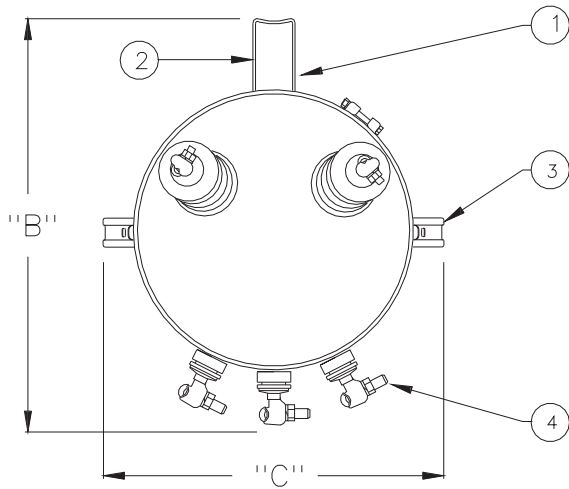

Note: 1 Each Item #1 15kVA & 1 Each Item #3 25kVA 120/240V provided as spares for community.

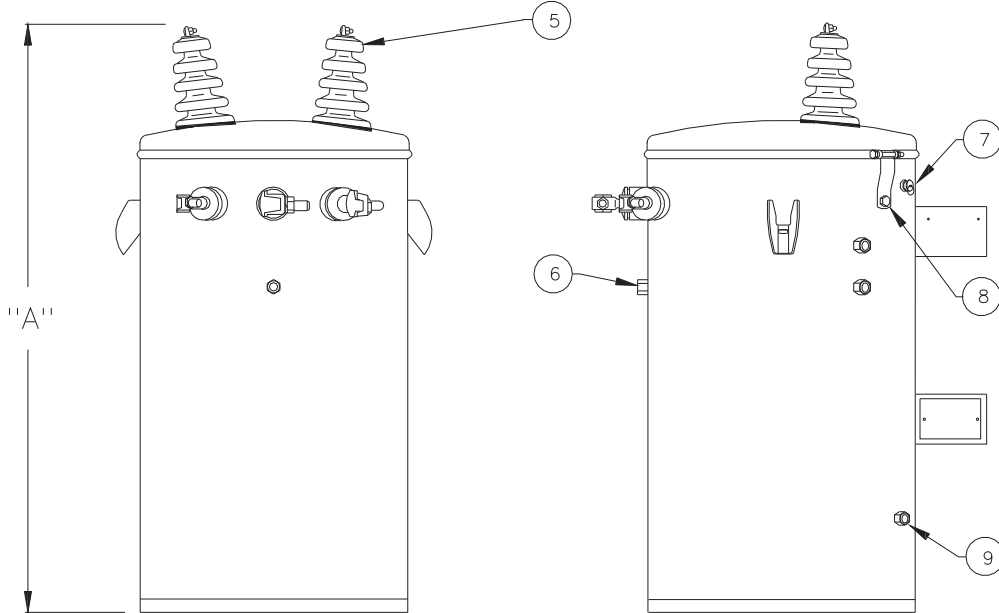

H.V. : 7200/12470Y 95BIL 2BU CSP CONV

L.V. : 120/240 3 OR 4 LVBU (QTY PER ANSI) 30 BIL

TAPS: 2 TAPS 2.5% ABOVE AND BELOW

PART	DESCRIPTION	QUANTITY
1	HANGER BRACKET TYPE: A	1 SET
2	NAMEPLATE (ON LOWER BRACKET) TYPE: (1) ALUMINUM NAMEPLATE (STANDARD)	1
3	LIFTING LUGS	2
4	LOW VOLTAGE BUSHINGS TYPE: PORCELAIN LVBU With EyeBolt	3
5	HIGH VOLTAGE BUSHINGS TYPE: EXTRA CREEP HV BUSHING	2
6	GROUNDING PROVISION: W/ GROUND STRAP (S)	1
7	P.R.V.: GENERIC.25 10PSI35SCFM (-01 OR -30)	1
8	COVER GROUND STRAP	1
9	TANK GROUNDING PROVISIONS: W/ (2) GROUND LUGS	2

ADDITIONAL FEATURES
 TAP SW: STANDARD DV &/OR TC, HOOKSTICK
 KVA DECAL: STANDARD 2.5 BLAKONWHITE KVA DECAL
 Oil TYPE: STD TX MINERAL OIL
 TK | CVR: MS | 3kV 304L SS
 CVR BAND: 3kV 304L SS

ITEM AND/OR STOCK #	KVA	DIMENSIONS IN INCHES			APPROX. GAL. OIL	APPROX. WEIGHT LBS.
		A	B	C		
1	15	35.2	21.8	19	12	311
3	25	37.2	22.1	19	12.5	381

ERMCO

CUSTOMER: ALASKA ENERGY AUTHORITY RFQ/SPEC #:

SCALE: NTS DATE: 05/12/22 BY: EAR QUOTE NUMBER: 653374

**** UNCONTROLLED ****