

# ALASKA ENERGY AUTHORITY - INVITATION TO BID (ITB) # 24106

Issue Date: January 31, 2024

## TENAKEE SPRINGS DERA PROJECT ENGINE-GENERATOR PURCHASE

Alaska Energy Authority (AEA) is soliciting bids to purchase commodities as indicated in Appendix C - Scope of Work, Appendix D - Bid Schedule, and Appendix E - Specifications.

**IMPORTANT NOTICE:** If you received this solicitation from the State of Alaska’s “Online Public Notice” web site, or you downloaded this solicitation from AEA’s procurement website, you must register on the online Plan Holders List to receive notification of subsequent amendments to the solicitation. Failure to register may result in the rejection of your bid. It is the bidder’s responsibility to ensure that they have received all addenda affecting this ITB. To register, go to [www.aideaaeprocurement.org](http://www.aideaaeprocurement.org) and select the Plan Holders Registration link and complete the Planholders Registration.

**BIDDER'S NOTICE:** By signature on this form, the bidder certifies that they comply with the following:

- (1) the bidder has a valid Alaska business license or will obtain one prior to award of any contract resulting from this ITB. If the bidder possesses a valid Alaska business license, the license number must be written below or one the following forms of evidence submitted with the bid:
  - a canceled check for the business license fee;
  - a copy of the business license application with a receipt date stamp from the State's business license office;
  - a receipt from the State’s business license office for the license fee;
  - a copy of the bidder’s valid business license;
  - a sworn notarized affidavit that the bidder has applied and paid for a business license;
- (2) the price(s) submitted was arrived at independently and without collusion, under penalty of perjury, and that the bidder is complying with:
  - the laws of the State of Alaska;
  - the applicable portion of the Federal Civil Rights Act of 1964;
  - the Equal Employment Opportunity Act and the regulations issued thereunder by the state and federal Government;
  - the Americans with Disabilities Act of 1990 and the regulations issued thereunder by the state and federal government;
  - the bid will remain open and valid for at least 30 days;
  - all terms and conditions set out in this Invitation to Bid (ITB).

If a bidder does not hold an Alaska Business License (1) at the time designated in the ITB for opening the Authority will disallow the Alaska Bidder Preference. Bids must also be submitted under the name as appearing on the bidder’s current Alaska business license in order to receive the Alaska Bidder Preference. If a bidder fails to comply with (2) of this paragraph, the Authority may reject the bid, terminate the contract, or consider the contractor in default.

Selwin C. Ray Contract Officer	_____ COMPANY SUBMITTING BID	*DOES YOUR BUSINESS QUALIFY FOR THE ALASKA BIDDER’S PREFERENCE? <input type="checkbox"/> YES <input type="checkbox"/> NO
813 West Northern Lights Blvd Anchorage, AK 99503	_____ AUTHORIZED SIGNATURE	*DOES YOUR BUSINESS QUALIFY FOR THE ALASKA VETERAN PREFERENCE? <input type="checkbox"/> YES <input type="checkbox"/> NO
Phone: (907) 771-3035 FAX: (907) 771-3044	_____ PRINTED NAME	*SEE ITB FOR EXPLANATION OF CRITERIA TO QUALIFY
Email: <a href="mailto:AEAProcurement@akenergyauthority.org">AEAProcurement@akenergyauthority.org</a>	_____ DATE	_____ TELEPHONE NUMBER
_____ ALASKA BUSINESS LICENSE NUMBER	_____ FEDERAL TAX ID NUMBER	_____ E-MAIL ADDRESS

# TABLE OF CONTENTS

<b>SECTION 1. INTRODUCTION &amp; INSTRUCTIONS .....</b>	<b>4</b>
SEC. 1.01 PURPOSE OF THE ITB .....	4
SEC. 1.02 DEADLINE FOR RECEIPT OF BIDS .....	4
SEC. 1.03 PRIOR EXPERIENCE .....	4
SEC. 1.04 INVITATION TO BID (ITB) REVIEW .....	4
SEC. 1.05 QUESTIONS PRIOR TO DEADLINE FOR RECEIPT OF BIDS .....	4
SEC. 1.06 SITE INSPECTION .....	4
SEC. 1.07 SUBMITTING BIDS .....	4
SEC. 1.08 BID FORMS .....	5
SEC. 1.09 PRICES .....	5
SEC. 1.10 PRE-BID CONFERENCE .....	5
SEC. 1.11 ASSISTANCE TO BIDDERS WITH A DISABILITY .....	5
SEC. 1.12 AMENDMENTS TO BIDS .....	5
SEC. 1.13 AMENDMENTS TO THE ITB .....	6
SEC. 1.14 ITB SCHEDULE .....	6
SEC. 1.15 ALTERNATE BIDS .....	6
SEC. 1.16 SUPPORTING INFORMATION .....	6
SEC. 1.17 FIRM, UNQUALIFIED, AND UNCONDITIONAL OFFER .....	6
<b>SECTION 2. CONTRACT INFORMATION .....</b>	<b>6</b>
SEC. 2.01 CONTRACT TERM .....	6
SEC. 2.02 CONTRACT ADMINISTRATION .....	7
SEC. 2.03 CONTRACT FUNDING .....	7
SEC. 2.04 CONTRACT EXTENSION .....	7
SEC. 2.05 CONTRACT CHANGES – UNANTICIPATED AMENDMENTS .....	7
SEC. 2.06 SUBCONTRACTORS .....	7
SEC. 2.07 JOINT VENTURES .....	7
SEC. 2.08 CONTRACT PERFORMANCE LOCATION .....	7
SEC. 2.09 RIGHT TO INSPECT PLACE OF BUSINESS .....	7
SEC. 2.10 SCOPE OF WORK AND SPECIFICATIONS .....	7
SEC. 2.11 F.O.B. POINT .....	8
SEC. 2.12 SHIPPING DAMAGE .....	8
SEC. 2.13 DELIVERY TIME .....	8
SEC. 2.14 INSPECTION & MODIFICATION - REIMBURSEMENT FOR UNACCEPTABLE DELIVERABLES .....	8
SEC. 2.15 CONTINUING OBLIGATION OF CONTRACTOR .....	8
SEC. 2.16 ESTIMATED QUANTITIES .....	8
SEC. 2.17 CONTRACT PRICE ADJUSTMENTS .....	8
SEC. 2.18 INFORMAL DEBRIEFING .....	8
SEC. 2.19 INDEMNIFICATION .....	8
SEC. 2.20 INSURANCE .....	9
SEC. 2.21 MANDATORY REPORTING .....	9
NOT APPLICABLE .....	9
<b>SECTION 3. CONTRACT INVOICING AND PAYMENTS .....</b>	<b>10</b>
SEC. 3.01 BILLING INSTRUCTIONS .....	10
SEC. 3.02 PAYMENT FOR AUTHORITY PURCHASES .....	10
SEC. 3.03 THIRD-PARTY FINANCING AGREEMENTS NOT ALLOWED .....	10
<b>SECTION 4. EVALUATION AND CONTRACTOR SELECTION .....</b>	<b>10</b>
SEC. 4.01 EVALUATION OF BIDS .....	10
SEC. 4.02 APPLICATION OF PREFERENCES .....	10
SEC. 4.03 ALASKA BIDDER PREFERENCE .....	10
SEC. 4.04 ALASKA VETERAN PREFERENCE .....	10

SEC. 4.05	USE OF LOCAL FOREST PRODUCTS .....	10
SEC. 4.06	LOCAL AGRICULTURAL AND FISHERIES PRODUCT PREFERENCE .....	10
SEC. 4.07	ALASKA PRODUCT PREFERENCE.....	10
SEC. 4.08	EMPLOYMENT PROGRAM PREFERENCE .....	10
SEC. 4.09	ALASKANS WITH DISABILITIES PREFERENCE .....	10
SEC. 4.10	PREFERENCE QUALIFICATION LETTER .....	11
SEC. 4.11	EXTENSION OF PRICES.....	11
SEC. 4.12	METHOD OF AWARD .....	11
SEC. 4.13	NOTICE OF INTENT TO AWARD.....	11
<b>SECTION 5.</b>	<b>GENERAL PROCESS AND LEGAL INFORMATION.....</b>	<b>11</b>
SEC. 5.01	ALASKA BUSINESS LICENSE AND OTHER REQUIRED LICENSES.....	11
SEC. 5.02	AUTHORITY.....	12
SEC. 5.03	COMPLIANCE (REFER TO APPENDIX A, A.9) .....	12
SEC. 5.04	SUITABLE MATERIALS, ETC. (REFER TO APPENDIX A, A.2) .....	12
SEC. 5.05	SPECIFICATIONS.....	12
SEC. 5.06	CONTRACTOR SITE INSPECTION.....	12
SEC. 5.07	ORDER DOCUMENTS.....	12
SEC. 5.08	HUMAN TRAFFICKING .....	12
SEC. 5.09	RIGHT OF REJECTION .....	13
SEC. 5.10	AUTHORITY NOT RESPONSIBLE FOR PREPARATION COSTS .....	13
SEC. 5.11	DISCLOSURE OF BID CONTENTS.....	13
SEC. 5.12	ASSIGNMENTS (REFER TO APPENDIX A, A.5).....	13
SEC. 5.13	FORCE MAJEURE (REFER TO APPENDIX A, A.14) .....	14
SEC. 5.14	DEFAULT (REFER TO APPENDIX A, A.4) .....	14
SEC. 5.15	DISPUTES (REFER TO APPENDIX A, A.3) .....	14
SEC. 5.16	SEVERABILITY (REFER TO APPENDIX A, A.16) .....	14
SEC. 5.17	CONTRACT CANCELLATION.....	14
SEC. 5.18	GOVERNING LAW; FORUM SELECTION (REFER TO APPENDIX A, A.18) .....	14
SEC. 5.19	SOLICITATION ADVERTISING .....	14
SEC. 5.20	QUALIFIED BIDDERS.....	14
SEC. 5.21	FEDERALLY IMPOSED TARIFFS .....	14
SEC. 5.22	PROTEST .....	15
<b>SECTION 6.</b>	<b>APPENDICES.....</b>	<b>16</b>
(a)	<i>Appendix A – General Conditions .....</i>	<i>16</i>
(b)	<i>Appendix B – Federal Assurances .....</i>	<i>16</i>
(c)	<i>Appendix C – Scope of Work.....</i>	<i>16</i>
(d)	<i>Appendix D - Bid Schedule .....</i>	<i>16</i>
(e)	<i>Appendix E – Specifications and Drawings.....</i>	<i>16</i>

## SECTION 1. INTRODUCTION & INSTRUCTIONS

### SEC. 1.01 PURPOSE OF THE ITB

Alaska Energy Authority (AEA) is soliciting bids to purchase commodities as indicated in Appendix C - Scope of Work, Appendix D - Bid Schedule, and Appendix E - Specifications.

### SEC. 1.02 DEADLINE FOR RECEIPT OF BIDS

Bids must be received no later than the time and date indicated in the ITB Schedule, Sec. 1.14, at which time they will be publicly opened. Late bids or amendments will be disqualified and not opened or accepted for evaluation. **The bid opening will be conducted telephonically.** Potential bidder may attend telephonically by calling **1-888-585-9008** and when prompted enter **351 122 943 #**.

### SEC. 1.03 PRIOR EXPERIENCE

Minimum prior experience, if applicable, is indicated in the attached Specifications. A bidder's failure to meet these minimum prior experience requirements will cause their bid to be considered non-responsive and rejected.

### SEC. 1.04 INVITATION TO BID (ITB) REVIEW

Bidders shall carefully review this ITB for defects and questionable or objectionable material. Comments concerning defects and questionable or objectionable material in the ITB should be made in writing and received by the contracting officer at least ten days before the bid opening date. This will allow time for an amendment to be issued if one is required. It will also help prevent the opening of a defective bid, upon which award cannot be made, and the resultant exposure of bidders' prices.

### SEC. 1.05 QUESTIONS PRIOR TO DEADLINE FOR RECEIPT OF BIDS

All questions must be in writing and directed to the contracting officer. The interested party must confirm telephone conversations in writing. Two types of questions generally arise. One may be answered by directing the questioner to a specific section of the ITB. These questions may be answered over the telephone. Other questions may be more complex and may require a written amendment to the ITB. The contracting officer will make that decision.

Contract Officer Selwin C. Ray

Phone 907-771-3035 Fax 907-771-3044

### SEC. 1.06 SITE INSPECTION

Not Applicable

### SEC. 1.07 SUBMITTING BIDS

Bids must be either Emailed, Hand Delivered or Mailed as follows:

EMAIL: [AEAProcurement@akenergyauthority.org](mailto:AEAProcurement@akenergyauthority.org)

HAND DELIVERED OR MAILED: The sealed bid package must be addressed as follows:

Alaska Energy Authority

Attention: **Selwin C. Ray**

Invitation to Bid (ITB) Number: **24106**

ITB TITLE: **TENAKEE SPRINGS DERA PROJECT ENGINE-GENERATOR PURCHASE**

**813 W NORTHERN LIGHTS BLVD**

**ANCHORAGE, AK 99503**

It is the bidder's responsibility to contact the issuing agency at **907-771-3035** to confirm that the bid has been received. The Authority is not responsible for unreadable, corrupt, or missing attachments.

## SEC. 1.08 BID FORMS

Bidders shall use the front page of this ITB and any other forms identified in this ITB for submitting bids. All bids must be signed by an individual authorized to bind the bidder to the provisions of the ITB.

### **BIDDER'S CERTIFICATION**

By signature on the bid, the bidder certifies that they comply with the following:

- A. the laws of the State of Alaska;
- B. the applicable portion of the Federal Civil Rights Act of 1964;
- C. the Equal Employment Opportunity Act and the regulations issued thereunder by the state and federal government;
- D. the Americans with Disabilities Act of 1990 and the regulations issued thereunder by the state and federal government;
- E. all terms and conditions set out in this ITB;
- F. the price(s) submitted was arrived at independently arrived and without collusion, under penalty of perjury; and
- G. that the bid will remain open and valid for at least 30 days.

If any bidder fails to comply with [a] through [g] of this paragraph, the Authority reserves the right to disregard the bid, terminate the contract, or consider the contractor in default.

### **CONFLICT OF INTEREST**

Each bid shall include a statement indicating whether or not the company or any individuals working on the contract has a possible conflict of interest (e.g., currently employed by the State of Alaska or formerly employed by the State of Alaska within the past two years) and, if so, the nature of that conflict. The contracting officer reserves the right to **consider a bid non-responsive and reject it** or cancel the award if any interest disclosed from any source could either give the appearance of a conflict or cause speculation as to the objectivity of the contract to be performed by the bidder.

## SEC. 1.09 PRICES

The bidder shall state prices in the units of issue on this ITB. Prices quoted in bids must be exclusive of federal, state, and local taxes. If the bidder believes that certain taxes are payable by the state, the bidder may list such taxes separately, directly below the bid price for the affected item.

## SEC. 1.10 PRE-BID CONFERENCE

Not Applicable

## SEC. 1.11 ASSISTANCE TO BIDDERS WITH A DISABILITY

Bidders with a disability may receive accommodation regarding the means of communicating this ITB or participating in the procurement process. For more information, contact the contracting officer no later than ten days prior to the deadline for receipt of bids.

## SEC. 1.12 AMENDMENTS TO BIDS

Amendments to or withdrawals of bids will only be allowed if acceptable requests are received prior to the deadline that is set for receipt of bids, in accordance with 3 AAC 109.170. No amendments or withdrawals will be accepted after the deadline unless the delay is due to an error of the procurement agency, in accordance with 3 AAC 109.360.

### SEC. 1.13 AMENDMENTS TO THE ITB

If an amendment is issued, it will be provided to all who were notified of the ITB and to Planholders who have registered on the ITB Plan Holders Registration at [www.aideaaeaprocurement.org](http://www.aideaaeaprocurement.org).

### SEC. 1.14 ITB SCHEDULE

The ITB schedule set out herein represents the Authority's best estimate of the schedule that will be followed. If an Activity of this schedule is changed, the schedule may be adjusted. All times are Alaska Time.

ACTIVITY	TIME	DATE
Issue Date / ITB Released		1/31/2024
Deadline for Protest (10 days prior to Bid Due)	2:00 PM	2/12/2024
Deadline for Comments/Questions (5 days prior to Bid Due)	2:00 PM	2/16/2024
Deadline for Receipt of Bids / Bid Due Date	2:00 PM	2/21/2024

This ITB does not, by itself, obligate the Authority. The Authority's obligation will commence when the contract is approved by the AEA Executive Director, or the Director's designee. Upon written notice to the contractor, the Authority may set a different starting date for the contract. The Authority will not be responsible for any work done by the contractor, even work done in good faith, if it occurs prior to the contract start date set by the Authority.

### SEC. 1.15 ALTERNATE BIDS

Bidders may only submit one bid. In accordance with 3 AAC 109.270 alternate bids (bids that offer something different than what is asked for) will be rejected.

### SEC. 1.16 SUPPORTING INFORMATION

Bidders shall submit all required technical, specification, and other supporting information with their bid, so that a detailed analysis and determination can be made by the contracting officer that the product offered meets the ITB specifications and that other requirements of the ITB have been met. However, provided a bid meets the requirements for a definite, firm, unqualified, and unconditional offer, the Authority reserves the right to request supplemental information from the bidder, after the bids have been opened, to ensure that the products or services offered completely meet the ITB requirements. The requirement for such supplemental information will be at the reasonable discretion of the Authority and may include the requirement that a bidder will provide a sample product(s) so that the Authority can make a first-hand examination and determination.

A bidder's failure to provide this supplemental information or the product sample(s), within the time set by the Authority, will cause the Authority to consider the offer non-responsive and reject the bid.

### SEC. 1.17 FIRM, UNQUALIFIED, AND UNCONDITIONAL OFFER

Bidders must provide enough information with their bid to constitute a definite, firm, unqualified and unconditional offer. To be responsive a bid must constitute a definite, firm, unqualified and unconditional offer to meet all the material terms of the ITB. Material terms are those that could affect the price, quantity, quality, or delivery. Also included as material terms are those which are clearly identified in the ITB and which, for reasons of policy, must be complied with at risk of bid rejection for non-responsiveness.

## SECTION 2. CONTRACT INFORMATION

### SEC. 2.01 CONTRACT TERM

The length of the contract will be from the date of award until the time of delivery and acceptance at the F.O.B. point.

## **SEC. 2.02 CONTRACT ADMINISTRATION**

The administration of this contract is the responsibility of the contracting officer or person appointed by AEA.

## **SEC. 2.03 CONTRACT FUNDING**

Refer to Appendix A, A.13. AEA estimates a budget of between **\$100,000.00** and **\$150,000.00** dollars for this contract.

## **SEC. 2.04 CONTRACT EXTENSION**

A month-to-month extension may only be executed by the contracting officer via a written contract amendment. Refer to Appendix A, A.15.

## **SEC. 2.05 CONTRACT CHANGES – UNANTICIPATED AMENDMENTS**

During the course of this contract, the contractor may be required to perform additional work. That work will be within the general scope of the initial contract. When additional work is required, the Authority will provide the contractor a written description of the additional work and request the contractor to submit a firm time schedule for accomplishing the additional work and a firm price for the additional work. Cost and pricing data must be provided to justify the cost of such amendments per 3 AAC 109.540.

The contractor will not commence additional work until the contracting officer has secured required Authority approvals necessary for the amendment and issued a written contract amendment.

## **SEC. 2.06 SUBCONTRACTORS**

Subcontractors will not be allowed.

## **SEC. 2.07 JOINT VENTURES**

Joint ventures will not be allowed.

## **SEC. 2.08 CONTRACT PERFORMANCE LOCATION**

The location(s) the work is to be performed, completed and managed at the vendors place of business.

The Authority will not provide workspace for the contractor. The contractor must provide its own workspace.

By signature on their bid, the bidder certifies that all services provided under this contract by the contractor and all subcontractors shall be performed in the United States.

If the bidder cannot certify that all work will be performed in the United States, the bidder must contact the contracting officer in writing to request a waiver at least 10 days prior to the deadline for receipt of bids.

The request must include a detailed description of the portion of work that will be performed outside the United States, where, by whom, and the reason the waiver is necessary.

Failure to comply with these requirements may cause the Authority to reject the bid as non-responsive, or cancel the contract.

## **SEC. 2.09 RIGHT TO INSPECT PLACE OF BUSINESS**

At reasonable times, the Authority may inspect those areas of the contractor's place of business that are related to the performance of a contract. If the Authority makes such an inspection, the contractor must provide reasonable assistance.

## **SEC. 2.10 SCOPE OF WORK AND SPECIFICATIONS**

Alaska Energy Authority (AEA) is soliciting bids to purchase commodities as indicated in Appendix C - Scope of Work, Appendix D - Bid Schedule, and Appendix E - Specifications.

### **SEC. 2.11 F.O.B. POINT**

The F.O.B. point for all items purchased under this contract is the final destination. Ownership of and title to the ordered items remains with the contractor until the items have been delivered to their final destination and are accepted by the Authority. The F.O.B. point is indicated in Appendix C - Scope of Work.

### **SEC. 2.12 SHIPPING DAMAGE**

The Authority will not accept or pay for damaged goods. The contractor must file all claims against the carrier(s) for damages incurred to items in transit from the point of origin to the ultimate destination. The Authority will provide the contractor with written notice when damaged goods are received. The Authority will deduct the cost of the damaged goods from the invoice prior to payment. The contractor must file all claims against the carrier(s) for reimbursement of the loss.

### **SEC. 2.13 DELIVERY TIME**

The Scope of Work indicates the desired delivery in calendar weeks. In the space provided on the Bid Schedule indicate the earliest firm delivery in calendar weeks required to make delivery after the receipt of an order. Failure to make an entry in the space provided will be construed as an offer to deliver by the desired delivery. Bids that specify deliveries in excess of the desired delivery may be considered non-responsive and may be rejected.

### **SEC. 2.14 INSPECTION & MODIFICATION - REIMBURSEMENT FOR UNACCEPTABLE DELIVERABLES**

The contractor is responsible for proving all products or the completion of all work set out in the contract. All products or work is subject to inspection, evaluation, and approval by the Authority. The Authority may employ all reasonable means to ensure that the work is progressing and being performed in compliance with the contract. The Authority may instruct the contractor to make corrections or modifications if needed in order to accomplish the contract's intent. The contractor will not unreasonably withhold such changes.

Substantial failure of the contractor to perform the contract may cause the Authority to terminate the contract. In this event, the Authority may require the contractor to reimburse monies paid (based on the identified portion of unacceptable products or work received) and may seek associated damages.

### **SEC. 2.15 CONTINUING OBLIGATION OF CONTRACTOR**

Refer to Appendix A, A.17.

### **SEC. 2.16 ESTIMATED QUANTITIES**

The quantities in this ITB are indicated in Appendix D - Bid Schedule.

### **SEC. 2.17 CONTRACT PRICE ADJUSTMENTS**

Not Applicable.

### **SEC. 2.18 INFORMAL DEBRIEFING**

When the contract is completed, an informal debriefing may be performed at the discretion of the contracting officer. If performed, the scope of the debriefing will be limited to the products provided or work performed by the contractor.

### **SEC. 2.19 INDEMNIFICATION**

The contractor shall indemnify, hold harmless, and defend the contracting agency from and against any claim of, or liability for error, omission or negligent act of the contractor under this agreement. The contractor shall not be required to indemnify the contracting agency for a claim of, or liability for, the independent negligence of the contracting agency. If there is a claim of, or liability for, the joint negligent error or omission of the contractor and



the independent negligence of the contracting agency, the indemnification and hold harmless obligation shall be apportioned on a comparative fault basis.

“Contractor” and “contracting agency”, as used within this and the following article, include the employees, agents and other contractors who are directly responsible, respectively, to each. The term “independent negligence” is negligence other than in the contracting agency’s selection, administration, monitoring, or controlling of the contractor and in approving or accepting the contractor’s work.

## SEC. 2.20 INSURANCE

Without limiting the contractor's indemnification, it is agreed that the contractor shall purchase at its own expense and maintain in force at all times during the performance of services under this agreement the following policies of insurance. Where specific limits are shown, it is understood that they shall be the minimum acceptable limits. If the contractor's policy contains higher limits, the Authority shall be entitled to coverage to the extent of such higher limits.

Certificates of Insurance must be furnished to the contracting officer prior to contract approval and must provide for a notice of cancellation, non-renewal, or material change of conditions in accordance with policy provisions. Failure to furnish satisfactory evidence of insurance or lapse of the policy is a material breach of this contract and shall be grounds for termination of the contractor's services. All insurance policies shall comply with and be issued by insurers licensed to transact the business of insurance under AS 21.

### **Proof of insurance is required for the following:**

- Workers' Compensation Insurance: The contractor shall provide and maintain, for all employees engaged in work under this contract, coverage as required by AS 23.30.045, and; where applicable, any other statutory obligations including but not limited to Federal U.S.L. & H. and Jones Act requirements. The policy must waive subrogation against the state.
- Commercial General Liability Insurance: covering all business premises and operations used by the contractor in the performance of services under this agreement with minimum coverage limits of \$300,000 combined single limit per occurrence.
- Commercial Automobile Liability Insurance: covering all vehicles used by the contractor in the performance of services under this agreement with minimum coverage limits of \$300,000 combined single limit per occurrence.

## SEC. 2.21 MANDATORY REPORTING

Not Applicable.

## **SECTION 3. CONTRACT INVOICING AND PAYMENTS**

### **SEC. 3.01 BILLING INSTRUCTIONS**

Invoices must be billed to the ordering agency's address shown on the individual Purchase Order, Contract Award or Delivery Order. The Authority will make payment after it receives the goods or services and the invoice. Questions concerning payment must be addressed to the Authority.

### **SEC. 3.02 PAYMENT FOR AUTHORITY PURCHASES**

Payment for agreements under \$500,000 for the undisputed purchase of goods or services provided to the Authority will be made within 30 days of the receipt of a proper billing or the delivery of the goods or services to the location(s) specified in the agreement, whichever is later.

### **SEC. 3.03 THIRD-PARTY FINANCING AGREEMENTS NOT ALLOWED**

Because of the additional administrative and accounting time required of the Authority when third party financing agreements are permitted, they will not be allowed under this contract.

## **SECTION 4. EVALUATION AND CONTRACTOR SELECTION**

### **SEC. 4.01 EVALUATION OF BIDS**

After bid opening, the contracting officer will evaluate the bids for responsiveness. Bids deemed non-responsive will be eliminated from further consideration. An evaluation may not be based on discrimination due the race, religion, color, national origin, sex, age, marital status, pregnancy, parenthood, disability, or political affiliation of the bidder.

### **SEC. 4.02 APPLICATION OF PREFERENCES**

Because the federal funding source prohibits the use of local preferences in the selection of contractors no Alaskan Bidder, Alaskan Products, or Alaskan Employment Program preferences will be used in determining the lowest responsive and responsible bidder.

### **SEC. 4.03 ALASKA BIDDER PREFERENCE**

Not Applicable.

### **SEC. 4.04 ALASKA VETERAN PREFERENCE**

Not Applicable.

### **SEC. 4.05 USE OF LOCAL FOREST PRODUCTS**

Not Applicable.

### **SEC. 4.06 LOCAL AGRICULTURAL AND FISHERIES PRODUCT PREFERENCE**

Not Applicable.

### **SEC. 4.07 ALASKA PRODUCT PREFERENCE**

Not Applicable.

### **SEC. 4.08 EMPLOYMENT PROGRAM PREFERENCE**

Not Applicable.

### **SEC. 4.09 ALASKANS WITH DISABILITIES PREFERENCE**

Not Applicable.

#### SEC. 4.10 PREFERENCE QUALIFICATION LETTER

Not Applicable.

#### SEC. 4.11 EXTENSION OF PRICES

In case of error in the extension of prices in the bid, the unit prices will govern; in a lot bid, the lot prices will govern.

#### SEC. 4.12 METHOD OF AWARD

Award will be made to the lowest responsive and responsible bidder. In order to be considered responsive, bidders must bid on all items.

#### SEC. 4.13 NOTICE OF INTENT TO AWARD

After the responses to this ITB have been opened and evaluated, a tabulation of the bids will be prepared. This tabulation, called a Notice of Intent to Award, serves two purposes. It lists the name of each company or person that offered a bid and the price they bid. It also provides notice of the Authority's intent to award a contract(s) to the bidder(s) indicated. A copy of the Notice of Intent will be emailed to each company or person who responded to the ITB. Bidders identified as the apparent low responsive bidders are instructed not to proceed until a Purchase Order, Contract Award, Lease, or some other form of written notice is given by the contracting officer. A company or person who proceeds prior to receiving a Purchase Order, Contract Award, Lease, or some other form of written notice from the contracting officer does so without a contract and at their own risk.

### SECTION 5. GENERAL PROCESS AND LEGAL INFORMATION

#### SEC. 5.01 ALASKA BUSINESS LICENSE AND OTHER REQUIRED LICENSES

Prior to the award of a contract, a bidder must hold a valid Alaska business license. However, in order to receive the Alaska Bidder Preference and other related preferences, such as the Alaska Veteran Preference and Alaskans with Disabilities Preference, a bidder must hold a valid Alaska business license prior to the deadline for receipt of bids. Bidders should contact the **Department of Commerce, Community and Economic Development, Division of Corporations, Business, and Professional Licensing, PO Box 110806, Juneau, Alaska 99811-0806**, for information on these licenses. Acceptable evidence that the bidder possesses a valid Alaska business license may consist of any one of the following:

- copy of an Alaska business license;
- certification on the bid that the bidder has a valid Alaska business license and has included the license number in the bid;
- a canceled check for the Alaska business license fee;
- a copy of the Alaska business license application with a receipt stamp from the state's occupational licensing office; or
- a sworn and notarized statement that the bidder has applied and paid for the Alaska business license.

You are not required to hold a valid Alaska business license at the time bids are opened if you possess one of the following licenses and are offering services or supplies under that specific line of business:

- fisheries business licenses issued by Alaska Department of Revenue or Alaska Department of Fish and Game,

- liquor licenses issued by Alaska Department of Revenue for alcohol sales only,
- insurance licenses issued by Alaska Department of Commerce, Community and Economic Development, Division of Insurance, or
- Mining licenses issued by Alaska Department of Revenue.

Prior the deadline for receipt of bids, all bidders must hold any other necessary applicable professional licenses required by Alaska Statute.

## SEC. 5.02 AUTHORITY

This ITB is written in accordance with 3 AAC 109 and 2 AAC 12.

## SEC. 5.03 COMPLIANCE (Refer to Appendix A, A.9)

## SEC. 5.04 SUITABLE MATERIALS, ETC. (Refer to Appendix A, A.2)

## SEC. 5.05 SPECIFICATIONS

Unless otherwise specified in this ITB, product brand names or model numbers specified in this ITB are examples of the type and quality of product required, and are not statements of preference. If the specifications describing an item conflict with a brand name or model number describing the item, the specifications govern. Reference to brand name or number does not preclude an offer of a comparable or better product, if full specifications and descriptive literature are provided for the product. Failure to provide such specifications and descriptive literature may be cause for rejection of the offer.

## SEC. 5.06 CONTRACTOR SITE INSPECTION

The Authority may conduct on-site visits to evaluate the bidder's capacity to perform the contract. A bidder must agree, at risk of being found non-responsive and having its bid rejected, to provide the Authority reasonable access to relevant portions of its work sites. Individuals designated by the contracting officer at the Authority's expense will make site inspection.

## SEC. 5.07 ORDER DOCUMENTS

Except as specifically allowed under this ITB, an ordering agency will not sign any vendor contract. The Authority is not bound by a vendor contract signed by a person who is not specifically authorized to sign for the Authority under this ITB. Unless otherwise specified in this ITB, the Authority Purchase Order, Contract Award and Delivery Order are the only order documents that may be used to place orders against the contract(s) resulting from this ITB.

## SEC. 5.08 HUMAN TRAFFICKING

By signature on their bid, the bidder certifies that the bidder is not established and headquartered or incorporated and headquartered in a country recognized as Tier 3 in the most recent United States Department of State's Trafficking in Persons Report.

The most recent United States Department of State's Trafficking in Persons Report can be found at the following website: <http://www.state.gov/j/tip/>

Failure to comply with this requirement will cause the Authority to reject the bid as non-responsive, or cancel the contract.

## SEC. 5.09 RIGHT OF REJECTION

Bidders must comply with all of the terms of this ITB, 3 AAC 109 (Procurement for Alaska Energy Authority Managed Grants), and all applicable local, state, and federal laws, codes, and regulations. The contracting officer may reject any bid that does not comply with all of the material and substantial terms, conditions, and performance requirements of the ITB.

Bidders may not qualify the bid nor restrict the rights of the Authority. If a bidder does so, the contracting officer may determine the bid to be a non-responsive counter-offer and the bid may be rejected.

Minor informalities that:

- do not affect responsiveness;
- are merely a matter of form or format;
- do not change the relative standing or otherwise prejudice other offers;
- do not change the meaning or scope of the RFP;
- are trivial, negligible, or immaterial in nature;
- do not reflect a material change in the work; or
- do not constitute a substantial reservation against a requirement or provision;

may be waived by the contracting officer.

The Authority reserves the right to refrain from making an award if it determines that to be in its best interest.

**A bid from a debarred or suspended bidder shall be rejected.**

## SEC. 5.10 AUTHORITY NOT RESPONSIBLE FOR PREPARATION COSTS

The Authority will not pay any cost associated with the preparation, submittal, presentation, or evaluation of any bid.

## SEC. 5.11 DISCLOSURE OF BID CONTENTS

All bid prices become public information at the bid opening. After the deadline for receipt of bids, all other bid material submitted become the property of the State of Alaska and may be returned only at the Authority's option. AAC 109.270 and 3 AAC 109.700 require public records to be open to reasonable inspection. All other bid information will be held in confidence during the evaluation process and prior to the time a Notice of Intent to Award is issued. Thereafter, bids will become public information.

Trade secrets and other proprietary data contained in bids may be held confidential if the bidder requests, in writing, that the contracting officer does so, and if the contracting officer agrees, in writing, to do so. The bidder's request must be included with the bid, must clearly identify the information they wish to be held confidential, and include a statement that sets out the reasons for confidentiality. Unless the contracting officer agrees in writing to hold the requested information confidential, that information will also become public after the Notice of Intent to Award is issued.

## SEC. 5.12 ASSIGNMENTS (Refer to Appendix A, A.5)

Bids that are conditioned upon the Authority's approval of an assignment will be rejected as non-responsive.

SEC. 5.13 FORCE MAJEURE (Refer to Appendix A, A.14)

SEC. 5.14 DEFAULT (Refer to Appendix A, A.4)

SEC. 5.15 DISPUTES (Refer to Appendix A, A.3)

SEC. 5.16 SEVERABILITY (Refer to Appendix A, A.16)

SEC. 5.17 CONTRACT CANCELLATION

The Authority reserves the right to cancel the contract at its convenience upon 30 calendar days written notice to the contractor. The Authority is only liable for payment in accordance with the payment provisions of this contract for supplies or services provided before the effective date of termination.

SEC. 5.18 GOVERNING LAW; FORUM SELECTION (Refer to Appendix A, A.18)

SEC. 5.19 SOLICITATION ADVERTISING

Public notice has been provided in accordance with 3 AAC 109.150.

SEC. 5.20 QUALIFIED BIDDERS

Per 2 AAC 12.875, unless provided for otherwise in the ITB, to qualify as a bidder for award of a contract issued under 3 AAC 109, the bidder must:

- 1) Add value in the contract by actually performing, controlling, managing, or supervising the services to be provided; or
- 2) Be in the business of selling and have actually sold on a regular basis the supplies that are the subject of the ITB.

If the bidder leases services or supplies or acts as a broker or agency in providing the services or supplies in order to meet these requirements, the contracting officer may not accept the bidder as a qualified bidder under 3 AAC 109.

SEC. 5.21 FEDERALLY IMPOSED TARIFFS

Changes in price (increase or decrease) resulting directly from a new or updated federal tariff, excise tax, or duty, imposed after contract award may be adjusted during the contract period or before delivery into the United States via contract amendment.

- **Notification of Changes:** The contractor must promptly notify the contracting officer in writing of any new, increased, or decreased federal excise tax or duty that may result in either an increase or decrease in the contact price and shall take appropriate action as directed by the contracting officer.
- **After-imposed or Increased Taxes and Duties:** Any federal excise tax or duty for goods or services covered by this contract that was exempted or excluded on the contract award date but later imposed on the contractor during the contract period, as the result of legislative, judicial, or administrative action may result in a price increase provided:
  - a) The tax or duty takes effect after the contract award date and isn't otherwise addressed by the contract;
  - b) The contractor warrants, in writing, that no amount of the newly imposed federal excise tax or duty or rate increase was included in the contract price, as a contingency or otherwise.
- **After-relieved or Decreased Taxes and Duties:** The contract price shall be decreased by the amount of any decrease in federal excise tax or duty for goods or services under the contract, except social security

or other employment taxes, that the contractor is required to pay or bear, or does not obtain a refund of, through the contractor's fault, negligence, or failure to follow instructions of the contracting officer.

- **Authority's Ability to Make Changes:** The Authority reserves the right to request verification of federal excise tax or duty amounts on goods or services covered by this contract and increase or decrease the contract price accordingly.
- **Price Change Threshold:** No adjustment shall be made in the contract price under this clause unless the amount of the adjustment exceeds \$250.

## SEC. 5.22 PROTEST

3 AAC 109.570 provides that an interested party may protest the content of the ITB.

An interested party is defined in 3 AAC 109.900 (17) as "an actual or prospective bidder or offeror whose economic interest might be affected substantially and directly by the issuance of a contract solicitation, the award of a contract, or the failure to award a contract."

If an interested party wishes to protest the content of a solicitation, the protest must be received, in writing, by the contracting officer at least ten days prior to the deadline for receipt of bids.

3 AAC 109 also provides that an interested party may protest the award of a contract or the proposed award of a contract.

If a bidder wishes to protest the award of a contract or the proposed award of a contract, the protest must be received, in writing, by the contracting officer within 10 days after the date the Notice of Intent to Award for the contract is issued.

A protester must have submitted a bid in order to have sufficient standing to protest the proposed award of a contract. Protests must include the following information:

- the name, address, and telephone number of the protester;
- the signature of the protester or the protester's representative;
- identification of the contracting agency and the solicitation or contract at issue;
- a detailed statement of the legal and factual grounds of the protest including copies of relevant documents; and the form of relief requested.

Protests filed by telex or telegram are not acceptable because they do not contain a signature. Fax copies containing a signature are acceptable.

The contracting officer will issue a written response to the protest. The response will set out the contracting officer's decision and contain the basis of the decision within the statutory time limit in 3 AAC 109.570. A copy of the decision will be furnished to the protester by certified mail, fax or another method that provides evidence of receipt.

All bidders will be notified of any protest. The review of protests, decisions of the contracting officer, appeals, and hearings, will be conducted in accordance with 3 AAC 109 – Procurement for Alaska Energy Authority Managed Grants.)

## SECTION 6. APPENDICES

- (a) Appendix A – General Conditions
- (b) Appendix B – Federal Assurances
- (c) Appendix C – Scope of Work
- (d) Appendix D - Bid Schedule
- (e) Appendix E – Specifications and Drawings



## APPENDIX A - GENERAL CONDITIONS

### A.1 INSPECTIONS AND REPORTS

The department may inspect, in the manner and at reasonable times it considers appropriate, all of the contractor's facilities and activities under this contract. The contractor shall make progress and other reports in the manner and at the times the department reasonably requires.

### A.2 SUITABLE MATERIALS, ETC.

Unless otherwise specified, all materials, supplies or equipment offered by the contractor shall be new, unused, and of the latest edition, version, model or crop and of recent manufacture.

### A.3 DISPUTES

If the contractor has a claim arising in connection with the contract that it cannot resolve with the Authority by mutual agreement, it shall pursue the claim, if at all, in accordance with the provisions of 2 AAC 108.915.

### A.4 DEFAULT

In case of default by the contractor, for any reason whatsoever, the Authority may procure the goods or services from another source and hold the contractor responsible for any resulting excess cost and may seek other remedies under law or equity.

### A.5 NO ASSIGNMENT OR DELEGATION

The contractor may not assign or delegate this contract, or any part of it, or any right to any of the money to be paid under it, except with the written consent of the Contracting Officer.

### A.6 NO ADDITIONAL WORK OR MATERIAL

No claim for additional supplies or services, not specifically provided in this contract, performed or furnished by the contractor, will be allowed, nor may the contractor do any work or furnish any material not covered by the contract unless the work or material is ordered in writing by the Contracting Officer.

### A.7 INDEPENDENT CONTRACTOR

The contractor and any agents and employees of the contractor act in an independent capacity and are not officers or employees or agents of the Authority in the performance of this contract.

### A.8 PAYMENT OF TAXES

As a condition of performance of this contract, the contractor shall pay all federal, State, and local taxes incurred by the contractor and shall require their payment by any subcontractor or any other persons in the performance of this contract. Satisfactory performance of this paragraph is a condition precedent to payment by the Authority under this contract.

### A.9 COMPLIANCE

In the performance of this contract, the contractor must comply with all applicable federal, state, and borough regulations, codes, and laws, and be liable for all required insurance, licenses, permits and bonds.

### A.10 CONFLICTING PROVISIONS

Unless specifically amended and approved by the Department of Law, the terms of this contract supersede any provisions the contractor may seek to add. The contractor may not add additional or different terms to this contract; AS 45.02.207(b)(1). The contractor specifically acknowledges and agrees that, among other things, provisions in any documents it sees to append hereto that purport to (1) waive the State of Alaska's sovereign immunity, (2) impose indemnification obligations on the Authority, or (3) seek to limit liability of the contractor for acts of contractor negligence, are expressly superseded by this contract and are void.

**A.11 OFFICIALS NOT TO BENEFIT**

Contractor must comply with all applicable federal or State laws regulating ethical conduct of public officers and employees.

**A.12 CONTRACT PRICES**

Contract prices for commodities must be in U.S. funds and include applicable federal duty, brokerage fees, packaging, and transportation cost to the FOB point so that upon transfer of title the commodity can be utilized without further cost. Prices for services must be in U.S. funds and include applicable federal duty, brokerage fee, packaging, and transportation cost so that the services can be provided without further cost.

**A.13 CONTRACT FUNDING**

Contractors are advised that funds are available for the initial purchase and/or the first term of the contract. Payment and performance obligations for succeeding purchases and/or additional terms of the contract are subject to the availability and appropriation of funds.

**A.14 FORCE MAJEURE**

The parties to this contract are not liable for the consequences of any failure to perform, or default in performing, any of their obligations under this Agreement, if that failure or default is caused by any unforeseeable Force Majeure, beyond the control of, and without the fault or negligence of, the respective party. For the purposes of this Agreement, Force Majeure will mean war (whether declared or not); revolution; invasion; insurrection; riot; civil commotion; sabotage; military or usurped power; lightning; explosion; fire; storm; drought; flood; earthquake; epidemic; quarantine; strikes; acts or restraints of governmental authorities affecting the project or directly or indirectly prohibiting or restricting the furnishing or use of materials or labor required; inability to secure materials, machinery, equipment or labor because of priority, allocation or other regulations of any governmental authorities.

**A.15 CONTRACT EXTENSION**

Unless otherwise provided, the Authority and the contractor agree: (1) that any holding over of the contract excluding any exercised renewal options, will be considered as a month-to-month extension, and all other terms and conditions shall remain in full force and effect, and (2) to provide written notice to the other party of the intent to cancel such month-to-month extension at least thirty (30) days before the desired date of cancellation.

**A.16 SEVERABILITY**

If any provision of the contract is declared by a court to be illegal or in conflict with any law, the validity of the remaining terms and provisions will not be affected; and, the rights and obligations of the parties will be construed and enforced as if the contract did not contain the particular provision held to be invalid.

**A.17 CONTINUING OBLIGATION OF CONTRACTOR**

Notwithstanding the expiration date of this contract, the contractor is obligated to fulfill its responsibilities until warranty, guarantee, maintenance and parts availability requirements have completely expired.

**A.18 GOVERNING LAW; FORUM SELECTION**

This contract is governed by the laws of the State of Alaska. To the extent not otherwise governed by Article 3 of this Appendix, any claim concerning this contract shall be brought only in the Superior Court of the State of Alaska and not elsewhere.

## APPENDIX B – FEDERAL ASSURANCES

Because this contract is funded with federal funds, the following contract provisions shall apply, where applicable, to all work performed on the contract by the contractor's own organization and by subcontractors. As provided in this Section, the contractor shall insert in each subcontract all of the stipulations contained in these Required Contract Provisions and further require their inclusion in any lower tier subcontracts or purchase orders that may in turn be made. The prime contractor shall be responsible for compliance by any subcontractor or lower tier subcontractor with all applicable Required Contract Provisions.

### B.1 BREACHES AND DISPUTE RESOLUTION.

**Contracts in excess of \$250,000.** Any dispute arising under this Contract which is not disposed of by mutual agreement shall be resolved in accordance with 2 AAC 108.915.

### B.2 TERMINATION.

**Contracts in excess of \$10,000.** This Contract may be terminated by either party upon 10 days written notice if the other party fails substantially to perform in accordance with its terms through no fault of the party initiating the termination ("Default Termination"). If the Authority terminates this agreement, the Authority will pay the Contractor a sum equal to the percentage of Work completed that can be substantiated either by the Contractor to the satisfaction of the Authority, or by the Authority. If the Authority becomes aware of any non-conformance with the Work or this agreement by the Contractor, the Authority will promptly notify the Contractor in writing of the non-conformance. Should the Contractor's Work remain in non-conformance after having received written notification, the percentage of total compensation attributable to the non-conforming Work may be withheld. The Authority may at any time suspend or terminate ("Convenience Termination") this Agreement for its needs or convenience with or without cause upon written notice. In the event of a Convenience Termination, the Contractor will be compensated for all authorized Work and authorized expenditures performed to the date of receipt of written notice of termination plus reasonable expenses. No fee or other compensation will be due for any incomplete portion of the Work.

### B.3 EQUAL EMPLOYMENT OPPORTUNITY.

Except as otherwise provided under [41 CFR Part 60](#), **all construction contracts** must include, and all contractors and subcontractors must comply with, the equal opportunity clause provided under [41 CFR 60-1.4\(b\)](#), in accordance with Executive Order 11246, "Equal Employment Opportunity" ([30 FR 12319](#), [12935](#), [3 CFR Part, 1964-1965](#) Comp., p. 339), as amended by Executive Order 11375, "Amending Executive Order 11246 Relating to Equal Employment Opportunity," and implementing regulations at [41 CFR part 60](#), "Office of Federal Contract Compliance Programs, Equal Employment Opportunity, Department of Labor."

### B.4 DAVIS-BACON ACT, AS AMENDED ([40 U.S.C. 3141-3148](#)).

**Construction contracts in excess of \$2,000** are required to comply with the Davis-Bacon Act ([40 U.S.C. 3141-3144](#), and [3146-3148](#)) as supplemented by Department of Labor regulations ([29 CFR Part 5](#), "Labor Standards Provisions Applicable to Contracts Covering Federally Financed and Assisted Construction"). Contractors are required to pay wages to laborers and mechanics at a rate not less than the prevailing wages specified in a wage determination made by the Secretary of Labor. In addition, contractors must pay wages not less than once a week. **A copy of the current prevailing wage determination issued by the Department of Labor is included in this solicitation.** Contract and subcontract awards must be conditioned upon the acceptance of the wage determination. All suspected or reported violations must be reported to the Federal awarding agency.

**B.5 COPELAND “ANTI-KICKBACK” ACT ([40 U.S.C. 3145](#))**

**Construction contracts in excess of \$2,000** are required to comply with the **Copeland “Anti-Kickback” Act ([40 U.S.C. 3145](#))**, as supplemented by Department of Labor regulations ([29 CFR Part 3](#), “Contractors and Subcontractors on Public Building or Public Work Financed in Whole or in Part by Loans or Grants from the United States”). Each contractor or subrecipient is prohibited from inducing, by any means, any person employed in the construction, completion, or repair of public work, to give up any part of the compensation to which he or she is otherwise entitled. All suspected or reported violations must be reported to the Federal awarding agency.

**B.6 CONTRACT WORK HOURS/SAFETY STANDARDS ACT ([40 U.S.C. 3701-3708](#)).**

**Construction contracts in excess of \$100,000** that involve the employment of mechanics or laborers are required to comply with [40 U.S.C. 3702](#) and [3704](#), as supplemented by Department of Labor regulations ([29 CFR Part 5](#)). Under [40 U.S.C. 3702](#) of the Act, each contractor is required to compute the wages of every mechanic and laborer on the basis of a standard work week of 40 hours. Work in excess of the standard work week is permissible provided that the worker is compensated at a rate of not less than one and a half times the basic rate of pay for all hours worked in excess of 40 hours in the work week. The requirements of [40 U.S.C. 3704](#) are applicable to construction work and provide that no laborer or mechanic must be required to work in surroundings or under working conditions which are unsanitary, hazardous or dangerous. These requirements do not apply to the purchases of supplies or materials or articles ordinarily available on the open market, or contracts for transportation or transmission of intelligence.

**B.7 RIGHTS TO INVENTIONS MADE UNDER A CONTRACT OR AGREEMENT.**

If the recipient or subrecipient wishes to enter into a contract with a small business firm or nonprofit organization regarding the substitution of parties, assignment or performance of experimental, developmental, or research work under that “funding agreement,” the recipient or subrecipient must comply with the requirements of [37 CFR Part 401](#), “Rights to Inventions Made by Nonprofit Organizations and Small Business Firms Under Government Grants, Contracts and Cooperative Agreements,” and any implementing regulations issued by the awarding agency.

**B.8 CLEAN AIR ACT ([42 U.S.C. 7401-7671Q](#).) AND THE FEDERAL WATER POLLUTION CONTROL ACT ([33 U.S.C. 1251-1387](#)), AS AMENDED**

**Contracts in excess of \$150,000** are required to comply with all applicable standards, orders or regulations issued pursuant to the Clean Air Act ([42 U.S.C. 7401-7671q](#)) and the Federal Water Pollution Control Act as amended ([33 U.S.C. 1251-1387](#)). Violations must be reported to the Federal awarding agency and the Regional Office of the Environmental Protection Agency (EPA).

**B.9 DEBARMENT AND SUSPENSION (EXECUTIVE ORDERS 12549 & 12689)**

A contract award **greater than or equal to \$25,000** (see [2 CFR 180.220](#)) must not be made to parties listed on the government wide exclusions in the System for Award Management (SAM), in accordance with the OMB guidelines at [2 CFR 180](#) that implement Executive Orders 12549 (3 CFR part 1986 Comp., p. 189) and 12689 (3 CFR part 1989 Comp., p. 235), “Debarment and Suspension.” **Contractors that apply or bid for an award exceeding \$25,000 must sign and submit the attached “Debarment” certification with their bid.**

**B.10 BYRD ANTI-LOBBYING AMENDMENT ([31 U.S.C. 1352](#))**

Each contractor and subcontractor must certify that it will not and has not used Federal appropriated funds to pay any person or organization for influencing or attempting to influence an officer or

employee of any agency, a member of Congress, officer or employee of Congress, or an employee of a member of Congress in connection with obtaining any Federal contract, grant or any other award covered by [31 U.S.C. 1352](#). Each tier must also disclose any lobbying with non-Federal funds that takes place in connection with obtaining any Federal award. Disclosures shall be forwarded from tier to tier up to the Authority. **Contractors that apply or bid for an award exceeding \$100,000 must sign and submit the attached “Lobbying” certification with their bid.**

### **B.11 PROCUREMENT OF RECOVERED MATERIALS.**

A state agency or agency of a political subdivision of a state and its contractors must comply with section 6002 of the Solid Waste Disposal Act, as amended by the Resource Conservation and Recovery Act. The requirements of Section 6002 include procuring only items designated in guidelines of the Environmental Protection Agency (EPA) at [40 CFR part 247](#) that contain the highest percentage of recovered materials practicable, consistent with maintaining a satisfactory level of competition, **where the purchase price of the item exceeds \$10,000 or the value of the quantity acquired during the preceding fiscal year exceeded \$10,000**; procuring solid waste management services in a manner that maximizes energy and resource recovery; and establishing an affirmative procurement program for procurement of recovered materials identified in the EPA guidelines.

### **B.12 PROHIBITION ON CERTAIN TELECOMMUNICATIONS AND VIDEO SURVEILLANCE SERVICES OR EQUIPMENT.**

Contractors and subcontractors are prohibited from entering into a contract (or extending or renewing a contract) to procure or obtain equipment, services, or systems that uses covered telecommunications equipment or services as a substantial or essential component of any system, or as critical technology as part of any system. As described in [Public Law 115-232](#), section 889, covered telecommunications equipment is telecommunications equipment produced by Huawei Technologies Company or ZTE Corporation (or any subsidiary or affiliate of such entities). See [§ 200.216](#).

### **B.13 DOMESTIC PREFERENCES FOR PROCUREMENTS.**

As appropriate and to the extent consistent with law, and to the greatest extent practicable, Contractor’s are required to provide a preference for the purchase, acquisition, or use of goods, products, or materials produced in the United States (including but not limited to iron, aluminum, steel, cement, and other manufactured products). The requirements of this section must be included in all contracts and purchase orders for work or products under this award. See [§ 200.322](#).

The funding for this project is exempt from the Buy American Act and therefore this purchase is not subject to the Buy American Act.

**DEBARMENT, SUSPENSION, INELIGIBILITY & VOLUNTARY EXCLUSION – 2 CFR 200.214; Executive Orders 12549 and 12689** [Applicable to all federally assisted contracts which exceed \$25,000]**Instructions for Certification:**

1. The certification in this clause is a material representation of fact upon which reliance was placed when this transaction was entered into. If it is later determined that the prospective contractor and lower tier participants knowingly rendered an erroneous certification, in addition to other remedies available to the Federal Government, the Authority may pursue available remedies, including suspension and/or debarment.
2. The prospective contractor and lower tier participants shall provide immediate written notice to the Authority if at any time the prospective contractor and lower tier participants learns that its certification was erroneous when submitted or has become erroneous by reason of changed circumstances.
3. The terms "covered transaction," "debarred," "suspended," "ineligible," "lower tier covered transaction," "participant," "persons," "lower tier covered transaction," "principal," "proposal," and voluntarily excluded," as used in this clause, have the meanings set out in the Definitions and Coverage sections of rules implementing Executive Orders [12549](#) and 12689. You may contact the Authority for assistance in obtaining a copy of those regulations.
4. The prospective contractor and lower tier participants agrees by submitting this bid or proposal that, should the proposed covered transaction be entered into, it shall not knowingly enter into any lower tier covered transaction with a person who is debarred, suspended, declared ineligible, or voluntarily excluded from participation in this covered transaction, unless authorized in writing by the Authority.
5. The prospective contractor and lower tier participants further agrees by submitting this bid or proposal that it will require the language of this certification be included in all subcontracts and all lower tier participants shall certify compliance with this requirement.
6. A participant in a covered transaction may rely upon a certification of a prospective participant in a lower tier covered transaction that it is not debarred, suspended, ineligible, or voluntarily excluded from the covered transaction, unless it knows that the certification is erroneous. A participant may decide the method and frequency by which it determines the eligibility of its principals. Each participant may, but is not required to, check the Non-procurement List issued by U.S. General Service Administration.
7. Nothing contained in the foregoing shall be construed to require establishment of system of records in order to render in good faith the certification required by this clause. The knowledge and information of a participant is not required to exceed that which is normally possessed by a prudent person in the ordinary course of business dealings.
8. Except for transactions authorized under Paragraph 5 of these instructions, if a participant in a covered transaction knowingly enters into a lower tier covered transaction with a person who is suspended, debarred, ineligible, or voluntarily excluded from participation in this transaction, in addition to all remedies available to the Federal Government, the Authority may pursue available remedies including suspension and/or debarment.

**Certification Regarding Debarment, Suspension, Ineligibility and Voluntary Exclusion Lower Tier Covered Transaction**

- (1) The prospective contractor and lower tier participants certifies, by submission of this bid or proposal, that neither it nor its "principals" is presently debarred, suspended, proposed for debarment, declared ineligible, or voluntarily excluded from participation in this transaction by any Federal department or agency.
- (2) When the prospective contractor and lower tier participants is unable to certify to the statements in this certification, such prospective participant shall attach an explanation to this proposal.

The Contractor, \_\_\_\_\_ certifies or affirms the truthfulness and accuracy of each statement of its certification and disclosure, if any. In addition, the Contractor understands and agrees that the provisions of 2 CFR §180 apply to this certification and disclosure, if any.

Signature of Contractor's Authorized Official: \_\_\_\_\_

Name and Title of Contractor's Authorized Official: \_\_\_\_\_

Date: \_\_\_\_\_

**CERTIFICATION REGARDING USE OF CONTRACT FUNDS FOR LOBBYING - 31 USC §1352**

[Applicable to all federally assisted contracts and to all related subcontracts which exceed \$100,000]

A bidder must submit to the Authority the below certification with its bid response for any federally assisted contract that exceeds \$100,000. Bids that are not accompanied by a completed certification may be rejected as nonresponsive.

1. The undersigned Contractor certifies, to the best of his or her knowledge and belief, that:

a. No Federal appropriated funds have been paid or will be paid, by or on behalf of the undersigned, to any person for influencing or attempting to influence an officer or employee of any Federal agency, a Member of Congress, an officer or employee of Congress, or an employee of a Member of Congress in connection with the awarding of any Federal contract, the making of any Federal grant, the making of any Federal loan, the entering into of any cooperative agreement, and the extension, continuation, renewal, amendment, or modification of any Federal contract, grant, loan, or cooperative agreement.

b. If any funds other than Federal appropriated funds have been paid or will be paid to any person for influencing or attempting to influence an officer or employee of any Federal agency, a Member of Congress, an officer or employee of Congress, or an employee of a Member of Congress in connection with this Federal contract, grant, loan, or cooperative agreement, the undersigned shall complete and **submit Standard Form-LLL, "Disclosure Form to Report Lobbying,"** in accordance with its instructions.

2. The undersigned also agrees that he or she shall require that the language of this certification be **included in all lower tier subcontracts, which exceed \$100,000** and that all such recipients shall certify and disclose accordingly.

3. This certification is a material representation of fact upon which reliance was placed when this transaction was made or entered into. Submission of this certification is a prerequisite for making or entering into this transaction imposed by 31 USC 1352 (as amended by the Lobbying Disclosure Act of 1995). Any person who fails to file the required certification shall be subject to a civil penalty of not less than \$10,000 and not more than \$100,000 for each such failure.

The Contractor, \_\_\_\_\_ certifies or affirms the truthfulness and accuracy of each statement of its certification and disclosure, if any. In addition, the Contractor understands and agrees that the provisions of 31 USC 3801, *et seq.*, apply to this certification and disclosure, if any.

Signature of Contractor's Authorized Official: \_\_\_\_\_

Name and Title of Contractor's Authorized Official: \_\_\_\_\_

Date: \_\_\_\_\_

End of Federal Assurances

### SCOPE OF WORK

1. **Scope** – Furnish engine-generator sets and accessories as indicated in Attachment D – Bid Schedule and in accordance with Attachment E – Specifications.
2. **Submittals** – Provide Submittals in accordance with Attachment E – Specifications. Submittals shall be provided to the Authority within 14 days of contract award.
3. **Testing** – Test engine-generator sets and provide test documentation in accordance with Attachment E – Specifications.
4. **Packaging** – Prepare, package, and label engine-generator sets and loose ship accessories as indicated in Attachment E – Specifications.
5. **O&M Manuals** – Provide a complete Operation and Maintenance (O&M) Manual for the engine-generator set in accordance with Attachment E – Specifications.
6. **F.O.B. Point** – Deliver all items to the Alaska Energy Authority, 2601 Commercial Drive, Anchorage, AK 99501.
7. **Delivery Date** – Delivery of all items to the F.O.B. Point is desired within 16 calendar weeks after receipt of an order. On the Bid Schedule provide a firm delivery in calendar weeks for each type of commodity where indicated.



Item No.	Item Description	Quan	Units	Unit Cost	Extended Cost
1	100ekW Engine-Generator & Accessories	2	Each		
				<b>TOTAL \$</b>	
Firm Delivery Date for Engine-Generators:					

**NOTES:**

- 1) See Attachment E for equipment specifications.
- 2) See Attachment C for scope of work including requirements for submittals, equipment packaging, etc.
- 3) See Attachment C for F.O.B. point and desired delivery.
- 4) Provide unit cost and extended cost for each item listed above. Provide a total cost for entire order.
- 5) Provide a firm delivery in calendar weeks where indicated above. Note that a firm delivery significantly later than the desired delivery date may cause a bid to be declared non-responsive.
- 6) For a bid to be considered responsive it must include the following:
  - a) This Bid Schedule completed as indicated.
  - b) The completed ITB response (page 1 of the ITB).
  - c) The completed Debarment Certificate, Appendix B, Page B-4.
  - d) The completed Lobbying Certificate Certificate, Appendix B, Page B-5.

**SECTION 26 32 13  
ENGINE GENERATORS**

**PART 1 - GENERAL**

**1.1 SCOPE**

- A. The Work included herein shall consist of providing, fabricating, and shop testing complete engine generators as specified herein.
- B. The engine generators shall be delivered complete and ready for installation.
- C. Provide all accessories as specified for all engine generators plus any additional components listed.

**1.2 RELATED REQUIREMENTS (*Not Used This Specification*)**

**1.3 SUBMITTALS**

- A. Provide each submittal in a single electronic file in Adobe Acrobat PDF format.
- B. Provide complete and accurate drawings of the equipment, including outline drawings and dimensional data which fully describe the height, width, and depth of the equipment; skid construction; schematics; wiring diagrams; and other relevant details.
- C. Provide mechanical and electrical performance data for the engine and generator.
- D. Provide manufacturer's catalog literature for all accessories and equipment.
- E. A torsional vibration analysis (TVA) has been prepared and accepted for the following engine generator combinations:

- 1. John Deere 4045AFM85 with Newage/Stamford UCI274E.

For any engine generator combinations not specifically listed above, a TVA shall be provided for the proposed engine generator combination within 14-days of contract award.

**1.4 REGULATORY COMPLIANCE**

The Environmental Protection Agency (EPA) has issued New Source Performance Standards (NSPS) regulations governing use of stationary diesel engines in remote areas of Alaska. These regulations were revised effective June 29, 2021. The following provision of 40 CFR applies to this solicitation:

- A. 40 CFR 60.4216(c) stipulates: Manufacturers, owners, and operators of stationary CI ICE that are located in remote areas of Alaska may choose to meet the applicable emission standards for emergency engines in §§ 60.4202 and 60.4205, and not those for non-emergency engines in §§ 60.4201 and 60.4204, except that for 2014 model year and later nonemergency CI ICE, the owner or operator of any such engine must have that engine certified as meeting at least the Tier 3 PM standards identified in appendix I of 40 CFR part 1039 or 40 CFR 1042.101.

In order to comply with EPA emissions requirements and also be compatible with the intended service applications, the diesel engine furnished under this solicitation shall be a new Tier 3 Marine certified engine.

### **1.5 QUALITY ASSURANCE**

- A. Equipment shall not have been in service at any time prior to delivery, except as required by tests.
- B. All equipment shall be designed, fabricated, and assembled in accordance with recognized and acceptable engineering and shop practices. Individual parts shall be manufactured to standard sizes and gauges so that repair parts, furnished at any time, can be installed in the field. Like parts of duplicate units shall be interchangeable.
- C. Equipment and components furnished under these specifications shall be in accordance with the requirements of applicable UL, NEC, IEEE, NEMA, and ANSI standards.

### **1.6 FABRICATOR QUALIFICATIONS**

The engine generators shall be furnished, assembled, and tested by a qualified fabricator (Fabricator) who is regularly engaged in the business of providing diesel engine driven generator equipment.

- A. The Fabricator must have staff with extensive experience in packaging diesel engine driven electrical generators. A list of five successful installations that key staff have worked on may be requested by the Authority after the bid opening and prior to award in order to verify Fabricator qualifications. The list must include installation date, description of installation, and a reference contact for each installation.
- B. The Fabricator must maintain a competent service organization that is available for field service calls. A description of the organization including resumes of key personnel may be requested by the Authority after the bid opening and prior to award in order to verify Fabricator qualifications.
- C. The Fabricator must have a fabrication facility with adequate space and appropriate equipment as required to perform the work. The Authority may inspect the Fabricator's shop after the bid opening and prior to award in order to verify Fabricator qualifications.

### **1.7 FABRICATOR WARRANTIES**

- A. The Fabricator shall warrant the work for a period of not less than 18 months after delivery to the F.O.B. point.
- B. In the event of equipment or component failure during the warranty period, the Fabricator shall repair or replace such defective equipment or components and bear all associated costs. Costs shall include material, parts, and labor. The Fabricator will be allowed to charge for travel and per diem expenses within Alaska related to warranty service at actual cost plus 10%. The Fabricator shall assist the Authority as directed to determine the cause of failure and pursue manufacturer's warranties

to the extent necessary to obtain replacement equipment and provide proof of action taken upon request.

- C. Provide a nametag on each piece of equipment that clearly identifies the party responsible for the warranty. Nametag shall include the name, address, and phone number, and shop order or Fabricator's serial number.

### **1.8 OPERATION AND MAINTENANCE MANUALS.**

- A. Provide one (1) complete bound set of operation and maintenance (O&M) manuals for each unique engine generator unit. Identification symbols for all replaceable parts and assemblies shall be included. Provide manuals for the following equipment:
  - 1. Engine.
  - 2. Generator.
  - 3. Voltage Regulator.
  - 4. All accessories.
- B. For each engine provide all available factory service publications including parts manuals, service manuals, component technical manuals, etc.
- C. For all other components of each engine generator unit provide:
  - 1. Equipment function, normal operating characteristics, and limiting conditions.
  - 2. Assembly, installation, alignment, adjustment, and checking instructions.
  - 3. Operating instructions for start-up, routine and normal operation, regulation and control, shutdown, and emergency conditions.
  - 4. Lubrication and maintenance instructions.
  - 5. Guide to "troubleshooting."
  - 6. Parts list.
  - 7. Outline, cross section, elevation, and assembly drawings
  - 8. Engineering data including all mechanical and electrical performance characteristics.
  - 9. Complete AC connection and three-line diagrams.
  - 10. Complete DC schematics including voltage regulator, fuel injector pump, sensors, switches, fuses, and all other devices.
- D. The operation and maintenance manuals shall be in addition to any instructions or parts list packed with or attached to the equipment when delivered, or any information submitted for review.
- E. Bind materials in locking three ring "D" style binders. Binder capacities shall not exceed 3 inches, nor shall material included exceed the designed binder capacity. If material to be bound exceeds capacity rating, multiple volumes shall be furnished. Binder capacity shall not be less than approximately 1/2 inch greater than the thickness of the material within the binder. Permanently label with project information on the front cover and edge.
- F. Where reduction is not practical, larger drawings shall be folded separately and placed in envelopes, which are bound into the manuals. Each envelope shall bear suitable identification on the outside.

- G. All information in the O&M manuals shall be new and original publications.

## **PART 2 - PRODUCTS**

### **2.1 GENERAL CONFIGURATION AND MANUFACTURERS**

- A. All units shall be complete skid mounted engine generators utilizing all new components.
- B. All units shall be configured as specified herein and shall include all accessories as indicated.
- C. Engines shall be rated for prime power duty at the horsepower (shaft) and electrical kilowatt (generator) ratings indicated for each unit. All engines shall be 1800 RPM unless specifically indicated otherwise. All starting and control systems shall be **12 VDC**.
- D. Prime Power Rating Nameplate: The Fabricator shall provide a permanently affixed nameplate listing the prime power rating as specified herein for each engine generator.
- E. Provide engines of the manufacturer and model as indicated in Paragraph 2.2 - Specific Configuration, no other substitutes except as specifically noted below.
- F. Approved equal substitutions of engines will be allowed only by Engineer's approval. To obtain approval, submittals must clearly demonstrate the following:
1. The substitute engine must meet all of the requirements of Paragraph 2.3
  2. The substitute engine manufacturer must have at least one factory authorized service representative with a permanent shop in Southcentral Alaska.
  3. The size and weight of the substitute engine must not exceed that of the specified engine by more than 10%.
  4. The physical layout, piping connections, and service access areas of the substitute engine must be sufficiently similar to that of the specified engine so that no major changes will be required to the power plant design.
  5. The substitute engine must meet or exceed the fuel efficiency rate of the specified engine. Provide fuel curve showing fuel consumption (kWh/gallon) at 25%, 50%, 75% and 100% of prime rated capacity.
  6. The substitute engine must be provided with a single jacket water cooling circuit without a separate aftercooler circuit.
  7. The substitute engine must meet or exceed the heat rejection to the jacket water circuit of the specified engine.
  8. The engine must not be equipped, or require to be equipped, with any exhaust emissions equipment including Exhaust Gas Recirculation, Diesel Oxidation Catalyst, Diesel Particulate Filter, or Selective Catalytic Reduction.
- G. Provide Newage/Stamford generators as indicated in the Specific Configuration requirements that follow or Kato equal, no other substitutes except as specifically noted below. The generator shall be rated for continuous output at the value and

temperature rise indicated at 0.8 power factor. The generator shall be 2/3 pitch winding, 3 phase, 277/480 volt, 12 lead reconnectable, with PMG excitation.

- H. If a Marathon or other generator of equivalent or greater capacity is provided it shall be modified and upgraded prior to installation. Prior to assembling to the engine the following tasks shall be performed:
1. Inspect generator internally for defects. If any defects are encountered immediately file a warranty claim with the manufacturer.
  2. Electrically test all windings.
  3. Check fasteners for proper torque.
  4. Replace diode plate mounting bolts with grade 8 bolts with nylok nuts.
  5. Insulate main rotor leads with phase paper or fabric wire loom. Secure leads with heat shrinkable polyester tape using epoxy on all knots.

## 2.2 SPECIFIC CONFIGURATION

Furnish Engine Generators of the capacity and configuration listed below:

- No. 1&2: **Engine** - 148 hp, 100 ekW prime, John Deere 4045AFM85, Tier 3 Marine. Configured for generator drive application with 11.5" diameter flywheel and SAE 3 adapter. Starting and Control Voltage = 12 VDC (convert as required).  
**Generator** - Minimum 125kW continuous at 105°C rise, Newage/Stamford UCI274E or Kato equal.

## 2.3 ENGINE STANDARD FEATURES

- A. Provide a skid mounted, 1800 RPM, diesel engine complete with generator/alternator and ready for service. The unit shall be of newest design and of recent manufacture.
- B. The engine shall be a four-cycle, water-cooled, direct injection diesel engine of 4 cylinder in-line configuration as indicated by model number and shall be provided with a gear driven coolant pump where offered by manufacturer.
- C. Cylinder Liners: The engines shall be provided with removable cylinder liners to facilitate field rebuilding.
- D. Horsepower: Certified engine power curves and fuel consumption at 25%, 50%, 75%, and 100% loading, shall be submitted showing the manufacturer's approval of the engine rating for engine generator prime power application. Special ratings or "continuous standby" ratings will not be acceptable.
- E. Fuel: The engine shall be capable of satisfactory performance on No. 1 or No. 2 Ultra Low Sulphur Diesel (ULSD) Fuel.
- F. Fuel System: The engine shall have manufacturer's engine mounted fuel filters with replaceable elements.
- G. Lubrication: The engine shall have a gear type lubricating oil pump for supplying oil under pressure to the main bearings, crankshaft bearings, pistons, piston pins, timing gears, camshaft bearings and valve rocker mechanism. Threaded spin-on type, full flow lubricating oil filters shall be provided.

- H. Starting: The engine shall be equipped with a 12 VDC electric starting system. The starting system shall be of sufficient capacity to crank the engine at a speed which will allow full diesel starting.
- I. Engine Control: All engine control functions will be performed by remote switchgear which will perform all start/stop, speed, paralleling, and load sharing control functions in addition to all engine function monitoring and safety shut downs. Engine manufacturer's electronic control panels shall not be provided.
- J. ECU and Isochronous Governor: Provide an Engine Control Unit (ECU) for interface with the switchgear. Program the ECU as shown in the typical payload file in Attachment A. All AFM engines with Generation II Marine Electronics shall be furnished with the following accessories:
  - 1. ECU mounting bulkhead with 10' long engine to ECU interconnect harness.
  - 2. Generator drive adapter harness ECU to 21 pin connection.
  - 3. Fuel pump relay.

#### **2.4 ENGINE MOUNTED ACCESSORIES, WIRING, AND PIPING**

- A. Fuel and Oil Hoses: All hoses for fuel, lube oil, vents, mechanical gauges, etc., shall be Aeroquip type FC300, Eaton Weatherhead H569 or approved equal. Minimum hose size shall be 5/16" (#6). Provide with re-useable JIC swivel type fittings. Push-on or barb type hose connections will not be allowed. Route hoses to avoid wear points and to ensure access to normal service points on the engine. Securely support hoses from engine and skid.
- B. Glycol Hoses: All hoses for glycol shall be Teflon hose with stainless steel outer braid, Eaton Weatherhead H243 or approved equal. Provide with re-useable plated steel straight JIC swivel ends with NPT adapters. Route hoses to avoid wear points and to ensure access to normal service points on the engine. Securely support hoses from engine and skid.
- C. Wire Loom: All wiring for control and instrumentation shall be routed in plastic loom. Provide tee fittings for all branch connections. Route loom to avoid wear points and to ensure access to normal service points on the engine. Securely support loom from engine and skid.
- D. Protective Guards: All moving parts and hot surfaces shall be provided with protective guards in accordance with U.L Standard 2200.
- E. Air Cleaners: The engine shall be provided with a metal canister air cleaner with a reusable oiled cotton stock element. John Deere, K&N, Parker, or approved equal. Open disposable type air filters or plastic canisters will not be accepted.
- F. Fuel Piping Termination: Fuel supply and return lines shall be routed to the front of generator skid for field connection to the plant piping. See Drawings for detailed configuration.
- G. Lube Oil Piping Termination: The oil drain line shall be routed to the front of generator skid for field connection to the plant piping. See Drawings for detailed configuration.

- H. Oil Level: The engine shall have a combination visual oil level site gauge with adjustable high and low level switches, Murphy L129CK1 or approved equal. Mount on rubber isolators and connect to engine with minimum #8 hoses. Carefully route upper vent hose to create a high point and connect directly into crankcase. Route lower hose to a connection directly on the oil pan. Do not tee lower hose into oil drain line. See Drawings for installation detail.
- I. Starting: A starter auxiliary relay shall be furnished and remote mounted in control wiring junction box:
  - 1. 12 VDC Relay: John Deere AT141011, Caterpillar 9X-8112, or Denso equal.
- J. Control Power: To provide 12VDC power to the control wiring junction box, a 30A circuit breaker with switch shall be mounted on the engine in the vicinity of the starter, Cooper 187-030-F-00 or approved equal.
- K. Sensors and Safety Controls: The engine shall be equipped with the following:
  - 1. Air Restriction Indicator/Switch, Combination visual indication and alarm switch. 1/8" MPT, 22.46" water column limit, manual reset, normally open switch with adjustable setpoint. Donaldson 135578-08420 or approved equal. Wire into engine harness and program ECU to recognize input. Shop adjust switch to close at 20" water column and verify function.
  - 2. Exhaust Gas Temperature. Manufacturer standard exhaust temperature sensor kit. Provide complete assembly including 14mm fitting and connectors for wiring harness. John Deere DZ104193. Wire into engine harness and program ECU to recognize input. See note 2 below for installation.

Note 1. The above listed sensors shall be independent from engine gauges and all other devices and sensors. Where standard factory furnished sensors for the above listed functions are required for operation of the ECU, provide additional duplicate sensors as specified. All sensors shall be installed on the engine and wired to the engine harness.

Note 2. Upon completion of shop testing, if exhaust gas temperature sensor is installed in flex, remove sensor and tywrap to engine in a secure location for shipping.

## 2.5 ENGINE MODIFICATIONS

- A. The crankcase ventilation filter and accessories shall be removed and a single point hose connection shall be left for field connection by others to a crankcase ventilation system.
- B. All engines shall be furnished without a charging alternator. Factory installed components shall be removed as required. Idler pulleys shall be added and belt guards shall be modified as required.
  - 1. Remove charging alternator.
  - 2. Install transient voltage protection diode.



3. Install industrial engine fan drive bearing and hub assembly. Replace belt as required. Install custom fabricated belt guard.
- C. All engines shall be furnished without a heat exchanger, coolant expansion tank, or accessory reduction gear drive. Factory installed components shall be removed as required. See Paragraph 2.6, Cooling System.

## **2.6 COOLING SYSTEM**

- A. Engine cooling shall be by remote radiators (provided by others) with coolant circulation driven by the engine coolant pump.
- B. Glycol Filter: Provide screw-on canister style filter element with 3/8" NPT connections on head, Wix #24019 head with #24069 element or approved equal. Mount head on steel bracket fixed to front or side of engine. Connect to engine with glycol hoses with 3/8" NPT quarter turn gauge cock isolation valves. Connect inlet to thermostat housing and connect outlet to water pump inlet. On thermostat housing connection provide 3/8" NPT tee fitting with plug for field connection of pre-heat line by others. When filters are provided as part of engine manufacturer's assembly the standard factory filters may be substituted for the above specified parts; however, equivalent mounting, connections, and isolation valves shall be included.
- C. Provide an air vent/pre-heat connection at the high point on the engine coolant system. Provide a threaded ball valve with a 1/2" male hose barb fitting.
- D. Modify engines as follows:
  1. Remove coolant tank and other accessories that are not required. Note that the 4045AFM85 engines have small ports in the coolant hose connection fittings that are overly restrictive. To provide adequate flow for prime power application remove the coolant discharge and suction connection fittings. Cut off hose ends and drill or bore out a 2.5 inch diameter hole. Furnish new 2 inch aluminum king nipples, cut off threads, and weld to housings. Reinstall connection fittings with discharge oriented vertically and suction oriented horizontally. Install a bent or welded section of 2 inch steel tube routed to the front of the left skid and supported from the skid. Provide hose barbs on each end and connect to engine suction fitting with short section of silicone hose as required. See photographs below for representative installation.

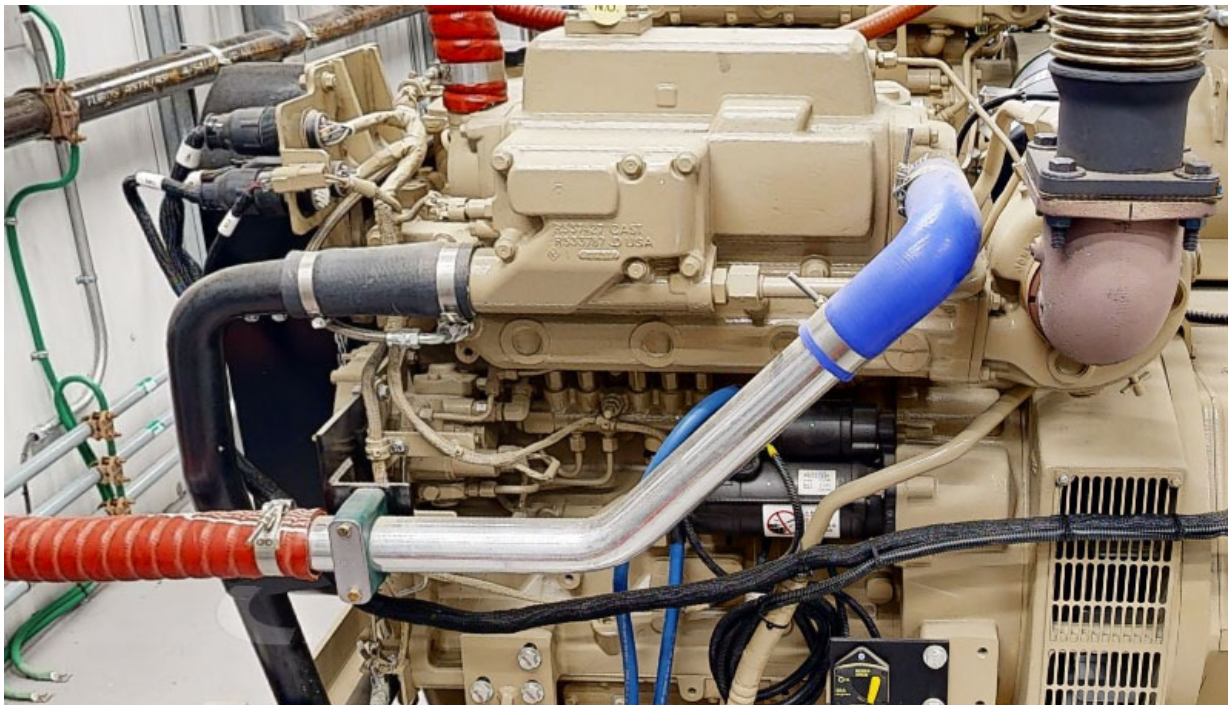

## 2.7 EXHAUST FLEX

- A. The turbocharger discharge shall be equipped with a 4-hole square “Cat” flange when available.
- B. A flexible, continuous, 18 inch long stainless steel exhaust flex connector with welded connections shall be furnished for each engine, Alaska Rubber, DME, Harco, or approved equal. Provide a mating connection to match the turbocharger at one end and a 4” ANSI 125/150# pattern flange at the opposite end. Provide gasket, bolts, v-clamp, or any other components required for connection to the turbocharger. Provide a 90° elbow where required for the flex to be installed vertically. Note that if the exhaust temperature sensor cannot be installed directly

in the turbocharger outlet connection, a 14mm FPT stainless steel boss fitting shall be welded into the flex between the engine connection and the corrugated hose.

## **2.8 LOOSE SHIP ACCESSORIES**

Provide the following accessories for each engine generator (unless otherwise indicated):

- A. Spring vibration isolators complete with mounting hardware, four (4) per each unit, minimum 1400# capacity, minimum 1000#/inch spring rate. Caldyn RJC 1430 or approved equal.
- B. Each engine shall be provided with two each #2/0 AWG arctic flex battery cables, 15 ft. long. All cables shall include compression type terminal ends shipped loose. One battery cable shall be red for the positive lead and the other shall be black for the negative lead. Provide plastic terminal covers. The battery cables shall be routed and supported as indicated on the Drawings.

## **2.9 DIAGNOSTIC GAUGE**

- A. Provide a J1939 multi-function monitoring panel programmed to receive unique John Deere fault codes, John Deere DG14 or approved equal. Note that the panel must be programmed for operation with a Marine Tier 3 engine, no exceptions. The panel shall be mounted on the side of the control wiring junction box. Provide with wiring harness as required for connection to ECU and battery power.

## **2.10 GENERATOR/ALTERNATOR**

- A. Generator shall be a single bearing, four pole, synchronous type. Generator shall be directly connected to the engine flywheel housing and driven through a flexible coupling to ensure permanent alignment. Windings shall 2/3 pitch, random wound, and lashed at the end turns to provide superior mechanical strength. The generator shall be brushless, 12 lead reconnectable, three phase, 60 Hz, 1800 RPM, and connected for 277/480V service.
- B. The rotating assembly shall be dynamically balanced to less than 2 mils peak to peak displacement and shall be designed to have an over speed withstand of 125% of rated speed for 2 minutes in accordance with NEMA MG1-32.
- C. Cast iron end brackets with bearing bores machined for an O-Ring to retard bearing outer race rotation and fabricated steel frames shall be used. Bearings shall be pre-lubricated, double shielded, ball type, single row Conrad, C3 fit. Minimum B-10 bearing life shall be 30,000 hours for single bearing units.
- D. Generator wiring diagram shall be permanently installed on the inside of the terminal enclosure cover.
- E. The insulation system of both the rotor and stator shall be of NEMA Class H materials or better and shall be synthetic and non-hygroscopic. The stator winding and rotor shall be coated with resin plus an epoxy sealant for extra moisture and abrasion resistance.
- F. The generator shall be equipped with a permanent magnet generator (PMG) excitation system. The system shall supply a minimum short circuit support current of 300% of the rating for 10 seconds. The rotating exciter shall use a three-phase full wave rectifier assembly with hermetically sealed silicon diodes protected

against abnormal transient conditions by a multi-plate selenium surge protector. The diodes shall be designed for safety factors of 5 times voltage and 1.5 times current.

- G. Voltage Regulator: The voltage regulator shall be compatible with the PMG excitation and shall control the output of the brushless AC generator by regulating the current into the exciter field. The voltage regulation shall be minimum 0.25% accuracy. Basler BE2000E, Marathon DVR 2400, or approved equal.
1. The voltage regulator shall be configured for rear mounting and shall be mounted inside of the control wiring junction box as indicated in the Drawings.
  2. The voltage regulator shall be connected to the 3 phase voltage sensing, field, and PMG on terminal blocks in the control wiring junction box as indicated in the Drawings.
- H. Factory Nameplate: The generator manufacturer shall provide a permanently affixed nameplate that provides the following information:
1. Rated voltage, phase, and power factor.
  2. Insulation class, winding type, and connection.
  3. Rated kW and amperage at specific temperature rise.
  4. Exciter voltage and current.
- I. Each generator shall be provided with a standard sized terminal compartment. The terminal compartment shall be provided with a load connection block to allow easy field termination of the load, neutral, and ground conductors. The generator neutral connection shall not be connected to the mounting skid or the generator frame. The neutral shall be isolated for field grounding by others at the switchgear or transformer.
- J. The generator shall be self-ventilated with a direct drive one-piece, cast aluminum alloy, unidirectional internal fan for high volume, low noise air delivery. Airflow shall be from opposite drive end through generator to drive end. The exciter shall be in the airflow.

## 2.11 MOUNTING SKID

- A. The engine generator shall be equipped with a suitable full length base frame (skid) for mounting the engine and generator. The skid shall be constructed from structural steel channel with ends beveled and plated for short term skidding and rolling of unit. **No formed or stamped steel base frame designs will be accepted.** Provisions shall be made so that the generator can slide back a minimum of 12" to access the rear main seal on the engine without removing the generator end off of the skid or requiring the use of blocking to support it. See the Drawings for skid design and layout.
- B. Provisions shall be made in the skid for the mounting of vibration isolators at locations as indicated on the Drawings. Wedge washers shall be welded in place on the skid to provide a flat surface for the vibration isolator lock nuts.
- C. Each engine generator shall be placed on the skid at the location indicated on the Drawings.

## 2.12 WIRING INTERFACE WITH REMOTE SWITCHGEAR

- A. A control wiring junction box shall be furnished with the generator. It will be field installed on a strut rack above the right hand side of the generator enclosure. The engine ECU mounting panel will be installed directly behind the junction box.
- B. Furnish the junction box with the following features:
  - 1. NEMA 12 steel enclosure with hinged door and screw down latches. B-Line, Hoffman or approved equal. See Drawings for size.
  - 2. The junction box orientation, device layout, terminal block layout, and labeling shall be as indicated on the Drawings.
  - 3. All wiring for control, monitoring, and safety shall be terminated on terminal blocks within the control wiring junction. The terminals shall be IDEC or approved equal, BNH15LW except where indicated 50A provide BNH50W. Terminals shall be mounted on DIN rail with heavy duty end anchors. Each terminal block and all wire terminations shall be individually numbered as indicated.
  - 4. Install the voltage regulator and the instrument panel as previously specified in the junction box as shown on the Drawings.
  - 5. Install an engine manufacturer's standard 21 pin customer connection for field connection to the engine ECU in the junction box as shown on the Drawings.
  - 6. Provide a minimum 3' long service connection cable with manufacturer's standard 21 pin customer connections for connecting to the engine ECU mounting panel.
- C. The DC power supply for the switchgear shall be provided from the engine starting batteries through the engine-mounted circuit breaker. Terminals shall be provided as indicated on the Drawings for supplying 12 or 24 VDC to the switchgear. All remote indication will be 24VDC, 4-20mA, or as otherwise indicated. All switches used for remote indication shall be rated for operation at 24 VDC.
- D. Label each control wiring junction box with the serial number of the associated engine. Connect to the engine and generator prior to performing the load test.

## 2.13 PAINTING

Each unit shall be painted John Deere industrial tan including engine, skid, and generator.

## 2.14 SPARE FILTERS

In addition to the filters installed on the engines, provide the following quantities of replacement filters for each engine plus break in oil. Package spare filters and oil in boxes and label each box with the engine model and the community name.

- A. Twelve (12) oil filters.
- B. Four (4) primary fuel filters.
- C. Four (4) secondary fuel filters.
- D. Two (2) air filters plus one air filter service kit.

- E. Four (4) glycol filters.
- F. Break in oil identical to oil installed in engine. One (1) gallon for each engine.

### **PART 3 - EXECUTION**

#### **3.1 SHOP ASSEMBLY**

- A. Prior to beginning assembly, thoroughly inspect engine and generator for manufacturing defects or for damage that may have occurred in shipping. Verify that the shipping arms on the front of the generator are intact and that rotor is properly centered. Check inside of generator for dirt or moisture and clean thoroughly.
- B. Replace the standard factory hardware used for attachment of the generator coupling disc to the engine flywheel with Grade 8 hex head bolts. Install heavy gauge washers, tighten and torque bolts in accordance with manufacturer's specifications, and paint pen mark after final torquing.
- C. Upon assembly of engine and generator on the skid, ensure proper alignment then adjust and secure supports to ensure alignment is maintained.
- D. Modify engines as specified previously. Install all accessories, devices, hoses, etc. as specified. Verify that all hose and wiring is properly routed, well supported, and secured to avoid wear points.
- E. Install exhaust temperature sensor and air restriction indicator/switch and connect to harness. Adjust air restriction switch to close at 20" water column and verify function and reset.
- F. ECU Mounting: Configure wiring harness so that ECU panel can be installed approximately 2' above the top of the generator enclosure directly behind the engine junction box.

#### **3.2 SHOP TESTS**

- A. Prior to shipment, the engine generator Fabricator shall perform shop tests on each unit at the shop where the engine generator is assembled. Supply sufficient notice to the Authority prior to performing tests. The Authority reserves the right to witness all tests. Test procedures shall conform to ASME, IEEE, and ANSI standards, and NEMA standard practices section on testing, as appropriate and applicable.
- B. The Fabricator shall provide all required mechanical and electrical equipment including but not limited to fuel supply, radiator, charge air cooler, exhaust, load bank, voltage regulator, etc.
- C. The Fabricator shall provide all required measuring and indicating devices. All devices shall be certified correct or correction data furnished for the device.
- D. Prior to performing the load test, the engine generator Fabricator shall perform the following:
  - 1. Verify that engine is filled with break in oil. The break in oil shall be approved by the engine manufacturer for 100 to 500 hour run time, John

- Deere Break-In Plus or approved equal. Pull a sample of the clean lube oil prior to the load test to be used for reference.
  2. Perform hydrostatic test on water jackets to ensure that water seals and water jackets are watertight. Test report shall indicate pressure at which test was made and the results.
  3. Connect engine coolant piping to radiator or heat exchanger. Note that all engine coolant circulation must be performed by the engine water pump without the benefit of any external pump or pressurized system.
  4. Install thermometer to monitor coolant return temperature entering the engine for comparison against the coolant discharge temperature.
  5. Connect engine air piping to charge air cooler.
  6. Connect engine and generator to the associated control wiring junction box.
- E. Engine Tests: Perform customary commercial shop 8 hour load test on each engine generator including, but not limited to, the following:
1. Prior to the 8 hour run, power up the ECU and program as shown in the typical payload file in Attachment A. Connect the ECU to an analog throttle input and verify that it is correctly responding including idle operation at input less than or equal to 0.5 VDC, 1800 RPM at 2.5 VDC, and variable RPM above and below 2.5 VDC. Note confirmation on the load test. Take screen shots to document the ECU programming and include with the load test reports for each engine.
  2. Place engine in continuous operation without stoppage for a period of not less than eight hours. Operate not less than one hour at each load point (1/2, 3/4, and full load) and 1 hour at 110 percent of rated load. If stoppage becomes necessary during this period, repeat the 8-hour run.
  3. Record the following data at the start, at 15-minute intervals, and at the end of each load run: Hz, kW load, fuel consumption, exhaust temperature, intake air temperature, jacket water temperature, coolant return temperature, lube oil temperature, lube oil pressure, manifold (boost) pressure, and crankcase vacuum.
  4. Tests shall indicate satisfactory operation and attainment of guarantees and specified performance.
- F. Provide completed test reports to the Authority. Reports shall include but not limited to the following:
1. Complete 8-hour load test data.
  2. Screen shots of throttle programming and confirmation of response.
  3. Photos of split oil filters as described below.
  4. Laboratory analysis of the clean lube oil sample and the sample pulled after the test as described below.

### **3.3 PREPARATION AND SHIPPING**

- A. Upon completion of testing perform the following steps to prepare for shipping:

1. Flush the cooling system with extended life 50/50 ethylene glycol mix, Shell Rotella ELC or approved equal. Install covers over the connections. Note that if testing was performed with extended life ethylene glycol solution the engine does not need to be flushed.
  2. Pull a sample of the lube oil. Send to a laboratory for analysis. Include the sample of clean lube oil pulled prior to the load test for reference comparison.
  3. Remove oil filter, split case, inspect contents and take photo to document. Note that if excessive or unusual metal fragments are found, contact the Authority immediately. Install new oil filter.
  4. Turn the engine at cranking speed with throttle control in full off position and use a sprayer to add a mixture of 50% VCI (volatile corrosion inhibitor) oil and 50% 30-weight engine oil into the air intake or turbocharger inlet.
  5. Continue spraying the VCI-oil mixture into the air intake or turbocharger inlet long enough to ensure the cylinders and exhaust ports are coated.
  6. Clean the outside of the engine and inspect and ensure that the engine and generator are covered by good quality paint. Correct any deficiencies.
  7. Spray a thin amount of VCI-oil mixture on the flywheel, ring gear teeth, and starter pinion. Install the covers to keep the vapors in.
  8. Install a positive mechanical seal consisting of a fitting plate and gasket on exhaust opening. Then install all covers and/or tape on any other openings. Ensure all covers are air tight and weatherproof. Use waterproof, weather resistant type tape. Do not install tape in such a manner as will damage paint when the tape is removed. Install a mechanical protective device over any protruding items, which may be vulnerable to damage during transportation.
- B. After preparing the equipment for shipping, package each engine generator separately as follows:
1. Coil wiring harnesses and secure control wiring junction box and ECU mounting panel to generator.
  2. Put a waterproof cover over the entire engine generator unit. Make the cover tight, but loose enough to let air circulate around the unit to prevent damage to exposed metal parts from condensation.
  3. All other included components (spare parts, loose items, etc.) shall be packaged individually in waterproof wrapping. Each individual component package shall then be packed in a box or crate, and each box/crate wrapped in waterproof wrapping to prevent corrosion to the components during extended periods of outside storage. All boxes or crates shall be palletized onto the minimum number of pallets, as required for the quantity and size of the boxes/crates.
  4. Each component package shall be sequentially numbered and marked for ease of identification. Each box/crate shall also be marked with a unique



identifying number. Each pallet shall be provided with a packing slip identifying the number of each box/crate on the pallet, in addition to a listing of each component package within each box/crate. Each pallet shall be marked (with two inch high letters/numbers), on all four sides and the top, with the project or community name.

5. Two copies of the packing slip identifying the quantity of pallets, the crates/boxes on each pallet, and the listing of component packages within each box/crate shall be provided to the Authority.
- C. Final payment will not be made until completion of the following:
1. All engine-generators and all loose ship parts have been accepted by the Authority at the F.O.B. Point.
  2. All required manuals have been accepted by the Authority at the F.O.B. Point.
  3. All test reports have been received and approved by the Authority.

*Note: The tasks described in the following paragraph will be included in the scope of the contract for installation in the power plant by others. It is not part of the engine-generator purchase scope and is provided here for reference only.*

#### **3.4 INSTALLATION AND COMMISSIONING**

- A. *Install the engine generators as indicated on the Drawings.*
- B. *Adjust spring vibration isolators as indicated on the Drawings.*
- C. *Ensure correct fit and alignment of all connections to not cause stress on engine connections or wear on piping, hoses, conduit, wiring, etc.*
- D. *Perform all functional testing and commissioning as required by the Contract Documents.*

#### **END OF WRITTEN SPECIFICATION**

**See The Following Attachments Which Follow:**

**Attachment A - Typical ECU Payload**

**Drawing M6 – Generator Fabrication Details**

**Drawing E3 - 12VDC Engine Control Wiring Junction Box**

# JOHN DEERE Custom Performance™

## PowerTech™ 4.5L AFM - Marine Genset

### Glossary

[Sensor Configuration](#)
[CAN Configuration](#)
[Output Configuration](#)
[Speed Control](#)
[Governors](#)  
[Engine Protection](#)
[Report](#)

## Pinout Report

PIN J2-A1 : CAN 1-High (Yellow)	PIN J2-D1 :	PIN J2-G1 :	PIN J2-K1 :
PIN J2-A2 :	PIN J2-D2 : Stop Lamp (-)	PIN J2-G2 : Excitation 4+	PIN J2-K2 : CAN Shield
PIN J2-A3 : Excitation #3+	PIN J2-D3 :	PIN J2-G3 : Excitation 4-	PIN J2-K3 :
PIN J2-A4 : Primary Analog Throttle	PIN J2-D4 :	PIN J2-G4 :	PIN J2-K4 :
PIN J2-B1 : CAN 1-Low (Green)	PIN J2-E1 :	PIN J2-H1 :	PIN J2-L1 : ECU Power
PIN J2-B2 : Keyswitch	PIN J2-E2 :	PIN J2-H2 :	PIN J2-L2 : ECU Ground
PIN J2-B3 :	PIN J2-E3 : Engine Protection Shutdown Override	PIN J2-H3 : CAN 2-Low	PIN J2-L3 : ECU Ground
PIN J2-B4 :	PIN J2-E4 :	PIN J2-H4 :	PIN J2-L4 : ECU Power
PIN J2-C1 :	PIN J2-F1 :	PIN J2-J1 :	PIN J2-M1 : ECU Power
PIN J2-C2 :	PIN J2-F2 :	PIN J2-J2 :	PIN J2-M2 : ECU Ground
PIN J2-C3 : Excitation #3-	PIN J2-F3 :	PIN J2-J3 : CAN 2-High	PIN J2-M3 :
PIN J2-C4 :	PIN J2-F4 :	PIN J2-J4 :	PIN J2-M4 : ECU Power

## Fault Code Report

Note: the following list of Fault Codes are those that are configured in the Trim Page, this list does not include all of the fault codes configured.

Fault 91.03: Primary Analog Throttle Out-of-Range High

Fault 91.04: Primary Analog Throttle Out-of-Range Low

## Standard Sensor Configuration

Help

Coolant Loss Switch Enable

Coolant Loss Switch Type

Air Filter Restriction Switch Enable - shared with Auxiliary Temperature Sensor

Air Filter Restriction Switch Type

Fuel Leak Switch Enable - shared with Configurable Switch 1

Fuel Leak Switch Type

Water-in-Fuel Sensor Disable

## Auxiliary Sensor Configuration

Help

Enable Auxiliary Temperature Sensor (Pin J2-D3) - shared with Air Filter Restriction Switch

Default (deg. C)

- Configurable Switch 1 Enable (Pin J2-F2 Switch to Power)  
Shared with Fuel Leak Switch

Switch Name

Switch Type

- Configurable Switch 2 Enable (Pin J2-E1 Switch to Power)

Switch Name

Switch Type

- Configurable Switch 3 Enable (Pin J2-J1 Switch to Ground)  
Shared with Auxiliary Derate Switch

Switch Name

Switch Type

- Configurable Switch 4 Enable (Pin J2-F1 Switch to Power)  
Shared with Bump Down Switch

Switch Name

Switch Type

- Configurable Switch 5 Enable (Pin J2-D4 Switch to Power)  
Shared with Bump Up Switch

Switch Name

Switch Type

Configurable Switch 6 Enable (Pin J2-J2 Switch to Power)

Switch Name

Switch Type

Configurable Switch 7 Enable (Pin J2-K1 Switch to Ground)  
Shared with Auxiliary Shutdown Switch

Switch Name

Switch Type

Configurable Switch 8 Enable (Pin J2-B3 Switch to Power)

Switch Name

Switch Type

Configurable Switch 9 Enable (Pin J2-E4 Switch to Power)  
Shared with Bump Enable Switch

Switch Name

Switch Type

Configurable Switch 10 Enable (Pin J2-H4 Switch to Excitation+)  
Shared with Isochronous Droop Switch

Switch Name

Switch Type

## Configurable Logic

[Help](#) Enable Configurable Logic 1Logic Name Active when the following conditions have been met for  seconds is   is Inactive when the following conditions have been met for  secondsUnused is  Unused is  Enable Configurable Logic 2Logic Name Active when the following conditions have been met for  seconds is   is Inactive when the following conditions have been met for  seconds

Unused is

Unused is

Enable Configurable Logic 3

Logic Name

Active when the following conditions have been met for  seconds

is

is

Inactive when the following conditions have been met for  seconds

Unused is

Unused is

**Shared CAN Bus Settings**

---

ECU Source Address

---

John Deere OEM Panel Function Instance

## Tachometer Output

[Help](#) Enable Tachometer Output

30 ▾ Pulses per Revolution

## Fuel Transfer Pump

[Help](#)

Select Fuel Transfer Pump Stanadyne Transfer Pump ▾

## Start Aid Control

[Help](#) Enable Glow Plugs

## Hardware Fault Lamps

[Help](#) Enable Warning Fault Lamp (J2-C1) - Shared with Starter Overspeed Relay / Configurable Output 3 Enable Stop Fault Lamp (J2-D2)

## Engine Mode Indication

[Help](#) Enable Engine Run Lamp / Alarm (J2-J4) - Shared with Configurable Output 1 Enable Engine Stop Lamp / Alarm (J2-E2)



## Configurable Outputs

[Help](#)

Enable Configurable Output 1 (J2-J4) - Shared with Run Mode Lamp/Alarm

Output Name

Output Type

Enable Output when  is

Default Output to  when  is

Lamp Test

Enable Configurable Output 2 (J2-K4)

Output Name

Output Type

Enable Output when  is

Default Output to  when  is

Lamp Test

Enable Configurable Output 3 (J2-C1) - Shared with Warning Fault Lamp

Output Name

Output Type

Enable Output when  is

Default Output to  when  is

Lamp Test



<b>Throttle</b>			
<input type="checkbox"/> Disable All Throttles			
<p><b>Digital Throttle</b></p> <p><input type="checkbox"/> Enable Digital Throttle</p> <p style="margin-left: 20px;"> <input type="radio"/> 2-State Throttle  <input checked="" type="radio"/> 3-State Throttle                     </p>	<p><b>Primary Analog Throttle</b></p> <p><input checked="" type="checkbox"/> Enable Primary Analog Throttle</p> <p style="margin-left: 20px;"><input type="checkbox"/> Self-Calibration Enable</p>	<p><b>Secondary Analog Throttle</b></p> <p><input type="checkbox"/> Enable Secondary Analog Throttle</p> <p style="margin-left: 20px;"><input type="checkbox"/> Self-Calibration Enable</p>	<p><b>PWM Throttle</b></p> <p><input type="checkbox"/> Enable PWM Throttle</p> <p style="margin-left: 20px;">                     PWM Frequency (Hz)  <input style="width: 50px;" type="text" value="200"/> </p> <p style="margin-left: 20px;">                     Minimum PWM Duty Cycle %  <input style="width: 50px;" type="text" value="10"/> </p> <p style="margin-left: 20px;">                     Maximum PWM Duty Cycle %  <input style="width: 50px;" type="text" value="90"/> </p>
<p><b>Throttle Adjustments</b></p> <p>Multiple Throttle Failure Condition Default:  <input style="width: 100%; border: 1px solid gray;" type="text" value="Default to Rated Speed"/> </p> <p>Throttle Out-of-Range Recovery:  <input style="width: 100%; border: 1px solid gray;" type="text" value="Rated Recovery"/> </p> <p>Minimum Throttle Offset:</p>			

<p>Offset: <input type="text" value="0"/> rpm increase</p> <p>Maximum Throttle Offset: <input type="text" value="0"/> rpm <input style="font-size: small; border: none; background-color: #f0f0f0; padding: 2px 5px; vertical-align: middle;" type="button" value="Decrease"/> ▼</p> <p style="text-align: center;"><input style="border: 1px solid #ccc; padding: 5px 15px; margin-top: 10px;" type="button" value="Envelope Calculation"/></p>	
--	--

<h2 style="margin: 0;">Torque Speed Control</h2> <div style="text-align: right;"><input style="border: 1px solid #ccc; padding: 2px 5px;" type="button" value="Help"/></div>		
<input type="checkbox"/> Enable TSC Source 1 Enable	<input type="checkbox"/> TSC1 Timeout Fault	<input type="text" value="3"/> Source Address 1
<input type="checkbox"/> Enable TSC Source 2 Enable	<input type="checkbox"/> TSC2 Timeout Fault	<input type="text" value="4"/> Source Address 2

<h2 style="margin: 0;">Governor Droop</h2> <div style="text-align: right;"><input style="border: 1px solid #ccc; padding: 2px 5px;" type="button" value="Help"/></div>	
<p>RPM of Droop <input type="text" value="0 Hz (Isochronous)"/> ▼</p> <p style="text-align: center;"><input style="border: 1px solid #ccc; padding: 5px 15px; margin-top: 10px;" type="button" value="Envelope Calculation"/></p>	

<h2 style="margin: 0;">Startup Acceleration Rate</h2> <div style="text-align: right;"><input style="border: 1px solid #ccc; padding: 2px 5px;" type="button" value="Help"/></div>	
<p>Acceleration Rate: <input type="text" value="Standard (Maximum)"/> ▼</p>	

## Governor Gains

[Help](#)

**Information:** The factory settings for the engine speed control (governor) parameters have been optimized for the majority of applications to provide the best combination of stability and response characteristics.

**DO NOT** change these settings from the defaults unless there is a significant problem with engine speed stability or response to load changes. Changing the governor gains from the defaults can aggravate instabilities in the system or lead to unacceptable response. Any changes must be evaluated to determine if the final performance is acceptable.

Low Speed Governor Gain	Use Selected Alternate Gain ▼
All Speed Governor Gain	Use Selected Alternate Gain ▼
Maximum Speed Governor Gain	Use Selected Alternate Gain ▼
Selected Alternate Gain	Alternate Gainset #1 ▼
Gain Adjustment Percentage	100 % (Valid range is 25% to 200%)

## Derates & Shutdowns

[Help](#)

### Standard (Level 1) Derates

Enable Standard (Level 1) Derates

### Standard Shutdowns

Refer to the Sensor Configuration section to enable optional sensors

Coolant Temperature Shutdown

Enabled ▼

Engine Overspeed Shutdown

Enabled ▼

### J1939 Enable/Disable Shutdowns

Allow Enable/Disable of Shutdowns by J1939 CAN Message

5 Controller Source Address

Engine will shutdown immediately after Engine Overspeed condition

Fuel Temperature Shutdown  ▼

Intake Manifold Air Temperature Shutdown  ▼

Oil Pressure Shutdown  ▼

Water-in-Fuel Shutdown  ▼

Coolant Loss Shutdown  ▼

Shutdown Timer  ▼

## Fault Indication

Enable Auxiliary Temperature Indication - Auxiliary Temperature Sensor is Disabled

Lamp Type  ▼    Aux Temperature Threshold 1  (deg. C)

Lamp Type  ▼    Aux Temperature Threshold 2  (deg. C)

Temperature Shutdown  ▼

## Auxiliary Derate

Auxiliary Derate Enable - shared with Configurable Switch 3

Auxiliary Derate Switch Input Type  ▼

Auxiliary Derate Amount

20% over 4 minutes ▼

 Override Auxiliary Derate at Engine Start

Override Auxiliary Derate Time

5 seconds ▼

## Auxiliary Shutdown

[Help](#)

**Warning: This is intended as a system protection shutdown. This is not intended to be used as an emergency stop.**

 Auxiliary Shutdown Enable - shared with Configurable Switch 7

Auxiliary Shutdown Switch Input Type

Normally Open ▼

**NOTE: Care should be taken to choose a switch type that matches desired behavior with common failure modes**

Auxiliary Shutdown Timer

Immediate ▼

 Override Auxiliary Shutdown at Engine Start

Override Auxiliary Shutdown Time

5 seconds ▼

## Shutdown Verify for Certification Testing

[Help](#)

Enable Engine Overspeed Verify - Engine Overspeed Shutdown has been enabled above in Standard Shutdowns

Engine Overspeed Threshold (rpm)

1700

 Enable Adjustable Coolant Temperature Shutdown

Coolant Temperature Shutdown Threshold (deg. C)

75

Enable Oil Pressure Shutdown for Certification Testing

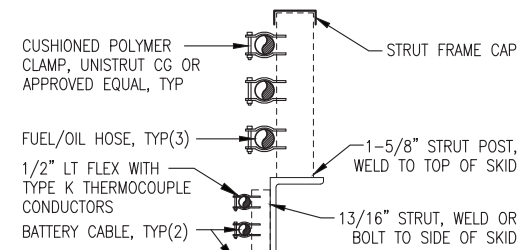

RIGHT SKID SECTION A-A

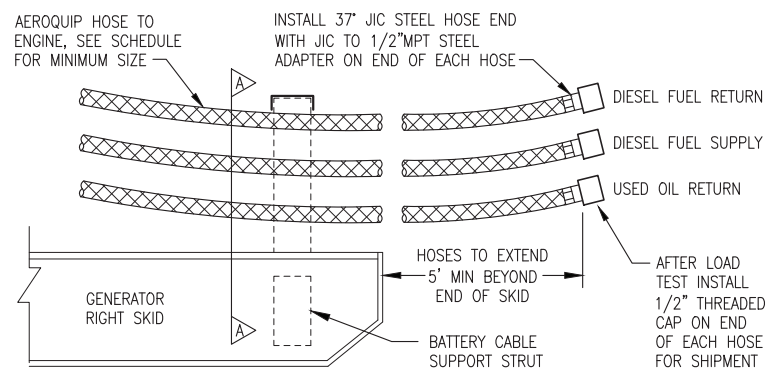

RIGHT SKID ELEVATION

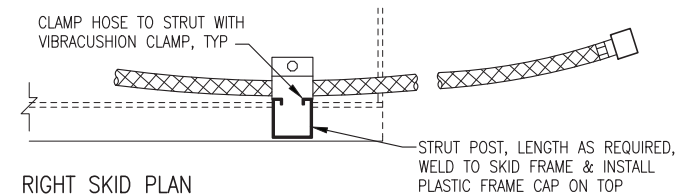

RIGHT SKID PLAN

1 FUEL & OIL HOSE TERMINATIONS  
M6 NO SCALE

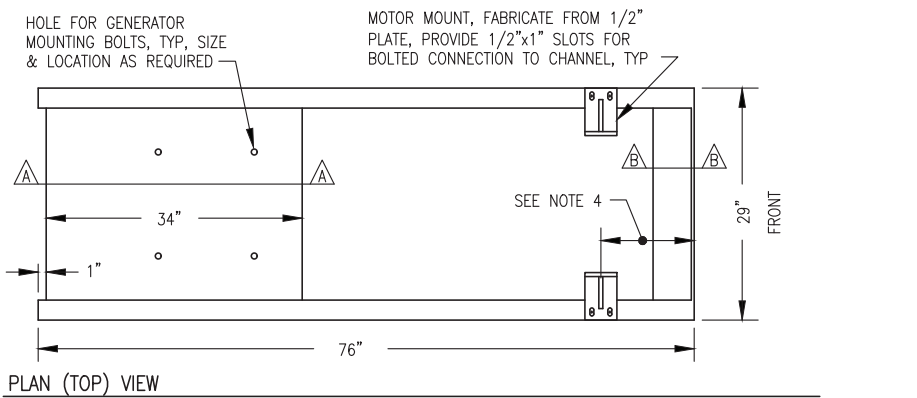

PLAN (TOP) VIEW

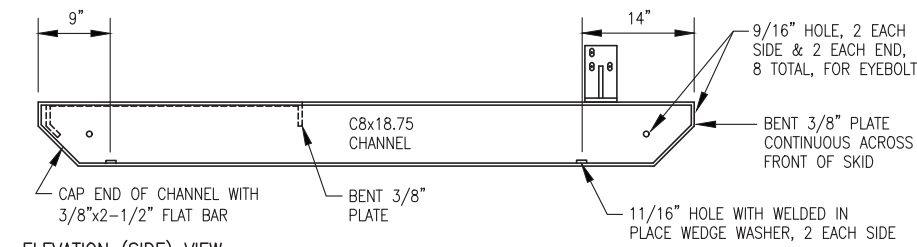

ELEVATION (SIDE) VIEW

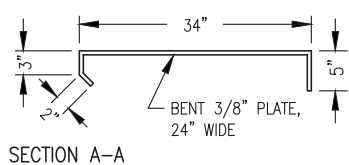

SECTION A-A

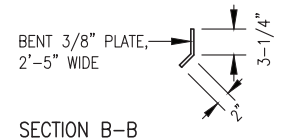

SECTION B-B

NOTES:

- 1) FABRICATE FROM ASTM A-36 STEEL. BEND PLATES & CUT ENDS OF CHANNELS AT 90° & 45° AS SHOWN.
- 2) EXCEPT WHERE INDICATED AS BOLTED MAKE ALL CONNECTIONS WITH CONTINUOUS WELDS (FILLET OR FULL-PENETRATION GROOVE AS REQUIRED) IN ACCORDANCE WITH CURRENT AWS STANDARD CODE.
- 3) ROUND ALL CORNERS & GRIND WELDS SMOOTH AFTER FABRICATION. PAINT TO MATCH ENGINE-GENERATOR.
- 4) PLACE ENGINE ON SKID SO THAT THE CENTERLINE OF THE EXHAUST RISER IS 39" FROM THE FRONT OF THE SKID.

2 GEN#1 & GEN#2 (JOHN DEERE 4045) SKID DESIGN  
M6 NO SCALE

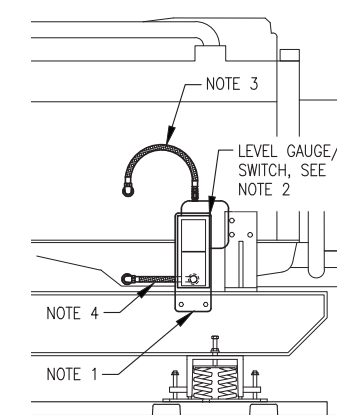



NOTES:

- 1) 1/4" STEEL SUPPORT PLATE PRE-DRILLED TO MATCH GAUGE/SWITCH MOUNTS AND BOTTOM HOSE ENTRANCE. BOLT TO INSIDE (BACK) OF CHANNEL SKID AT HEIGHT AS REQUIRED TO CENTER GAUGE AT NORMAL FULL OIL LEVEL.
- 2) MOUNT OIL LEVEL GAUGE/SWITCH TO STEEL SUPPORT PLATE WITH RUBBER SHOCK MOUNTS. ADJUST SWITCH CONTACTS TO 1/2" ABOVE AND BELOW NORMAL FULL LEVEL. PAINT MARK A RED LINE AT BOTH SWITCH LEVELS.
- 3) CONNECT TOP (VENT) PORT TO ENGINE CRANK CASE WITH #8 HOSE WITH 1/2" OR 3/8" NPT JIC SWIVEL ENDS. ROUTE UPPER HOSE WITH HIGH POINT 4" MIN ABOVE TOP OF GAUGE.
- 4) CONNECT BOTTOM PORT TO ENGINE OIL PAN WITH #8 HOSE WITH 1/2" OR 3/8" NPT JIC SWIVEL ENDS. DO NOT TEE INTO OIL DRAIN LINE. ROUTE LOWER HOSE BACK THROUGH PRE-DRILLED HOLE IN STEEL PLATE.

3 OIL LEVEL GAUGE/SWITCH INSTALLATION  
M6 NO SCALE

ISSUED FOR  
GENERATOR  
PROCUREMENT  
JAN 2023

 <b>ALASKA ENERGY AUTHORITY</b>		
PROJECT:	TENAKEE SPRINGS 2024 DERA POWER PLANT UPGRADE PROJECT	
TITLE:	GENERATOR FABRICATION DETAILS	
 P.O. 111405, Anchorage, AK 99511 (907)349-0100	DRAWN BY: JTD	SCALE: AS NOTED
	DESIGNED BY: BCG	DATE: 1/22/24
FILE NAME: TENADERA M1-M7	SHEET:	M6
PROJECT NUMBER:		



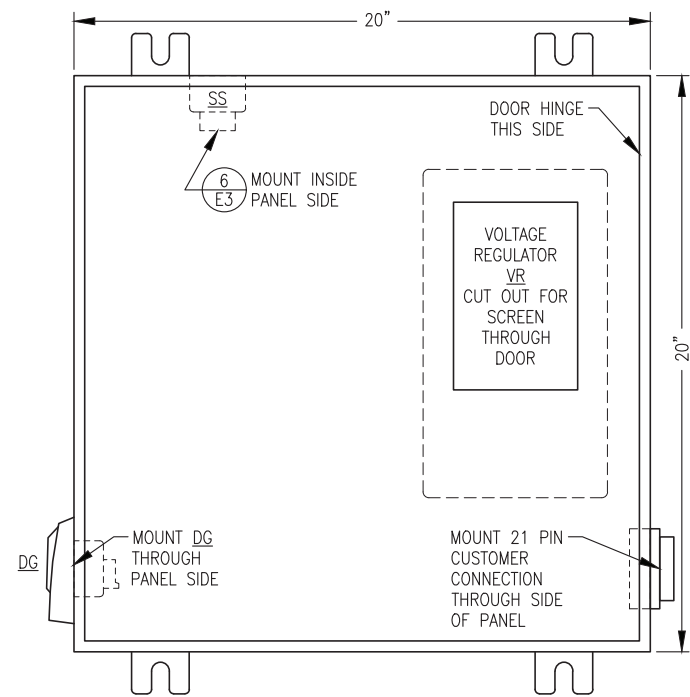

**1** JUNCTION BOX FRONT PANEL LAYOUT  
E3 NO SCALE

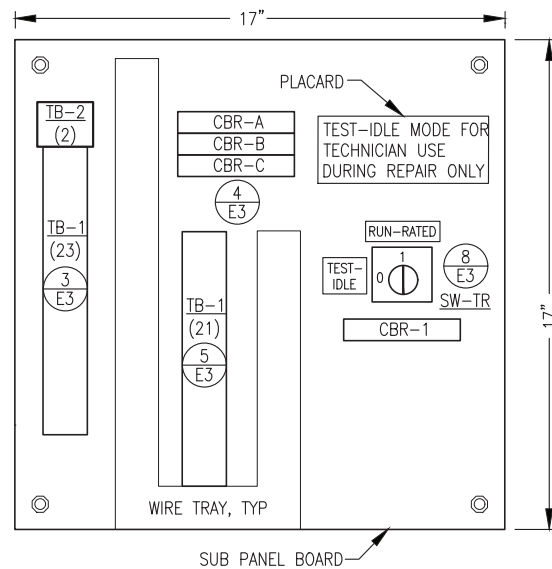

**2** JUNCTION BOX SUB PANEL LAYOUT  
E3 NO SCALE

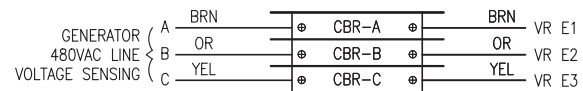

**4** CIRCUIT BREAKER CONNECTIONS  
E3 NO SCALE

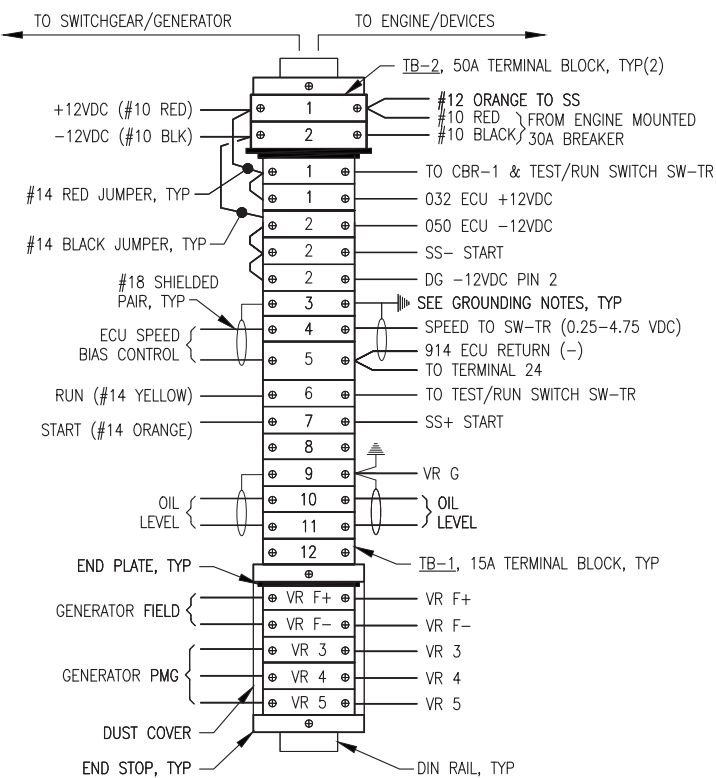

**3** TERMINAL STRIP CONNECTIONS  
E3 NO SCALE

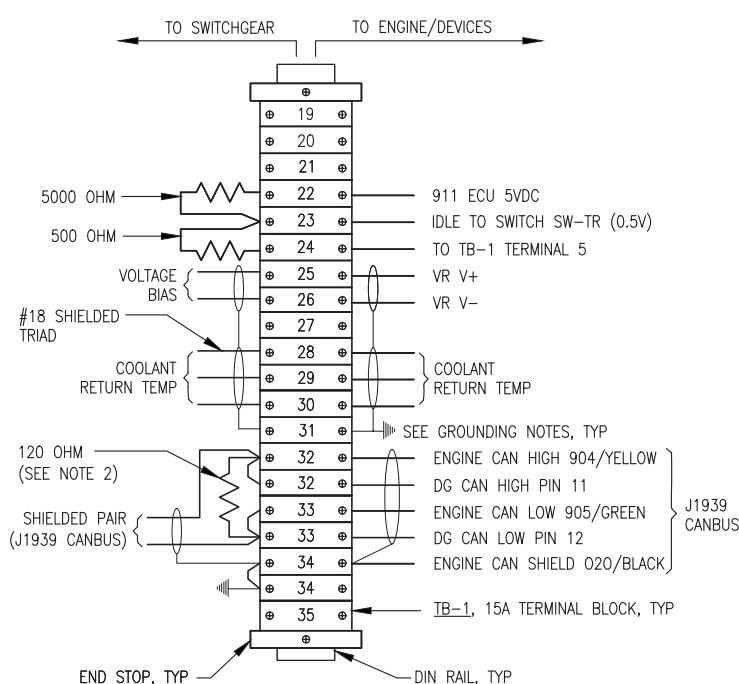

NOTES: 1) ALL RESISTORS 0.25W.  
2) REMOVE RESISTOR IF ENGINE WIRING HARNESS HAS 120 OHM END OF LINE RESISTOR.

**5** TERMINAL STRIP CONNECTIONS  
E3 NO SCALE

TAG	MANUFACTURER	MODEL	DESCRIPTION
21 PIN	JOHN DEERE OR DEUTZ		21 PIN CUSTOMER CONNECTION ASSY
CBR-A/B/C	ALLEN-BRADLEY	1489-M1-C010	RAIL MOUNT CIRCUIT BREAKER, 1P, 1A
CBR-1	ALLEN-BRADLEY	1489-M1-C050	RAIL MOUNT CIRCUIT BREAKER, 1P, 5A
DG	JOHN DEERE	DG-14	DIAGNOSTIC GAUGE WITH HARNESS
ENCL.	PROGRAMMED FOR MARINE TIER 3 WITH UNIQUE JOHN DEERE FAULT CODE		
SS	HOFFMAN	A20H20ALP	20x20x8" NEMA 12 BACK PANEL
SW-TR	HOFFMAN	A20P20	STARTER AUXILIARY SOLENOID, 12V
	JOHN DEERE	AT141011	CHANGEOVER SWITCH, 12A, 2P
	ALLEN-BRADLEY	194L-A12-225-2	90 DEGREE I-O HANDLE
TB-1	ALLEN-BRADLEY	194L-HE-4A-175	50A DIN RAIL-MOUNT TERMINAL BLOCK
TB-2	ALLEN-BRADLEY	194L-HE-4A-175	50A DIN RAIL-MOUNT TERMINAL BLOCK
VR	IDECC	BNH15LW	15A DIN RAIL-MOUNT TERMINAL BLOCK
	IDECC	BNH50W	50A DIN RAIL-MOUNT TERMINAL BLOCK
	BASLER	BE2000E	DIGITAL VOLTAGE REGULATOR
	MARATHON	DVR 2400	DIGITAL VOLTAGE REGULATOR

BRAND SPECIFIC NOTE: SPECIFIC PARTS MANUFACTURER AND MODEL SELECTED NOT ONLY TO MEET PERFORMANCE FUNCTION BUT ALSO TO COORDINATE AND INTERFACE WITH OTHER DEVICES AND SYSTEMS. APPROVED EQUAL SUBSTITUTIONS WILL BE ALLOWED ONLY BY ENGINEER'S APPROVAL. TO OBTAIN APPROVAL, SUBMITTALS MUST CLEARLY DEMONSTRATE HOW SUBSTITUTE ITEM MEETS OR EXCEEDS SPECIFIED ITEM QUALITY AND PERFORMANCE CHARACTERISTICS AND ALSO COMPLIES WITH MECHANICAL AND/OR ELECTRICAL CONNECTIONS AND PHYSICAL LAYOUT REQUIREMENTS.

**SHOP FABRICATION NOTES:**

- 1) PROVIDE ASSEMBLY WITH ALL DEVICES AND WIRING INDICATED.
- 2) INSTALL IN A NEMA 12 ENCLOSURE WITH MOUNTING FLANGES AT BACK, A MIN 14 GAUGE INTERIOR BACK PANEL AND HINGED LOCKABLE DOOR. SIZE AS INDICATED.
- 3) PROVIDE DIN RAIL, TERMINAL END PLATES, TERMINAL END STOPS, TERMINAL DUST COVERS AND OTHER MISCELLANEOUS HARDWARE AS REQUIRED TO MATCH TERMINALS. LABEL ALL TERMINALS EXACTLY AS INDICATED ON THE DETAILS.
- 4) ALL WIRE #14AWG EXCEPT WHERE SPECIFICALLY INDICATED OTHERWISE. LABEL BOTH ENDS OF ALL JUMPERS WITH THE ENGINE PANEL TERMINAL NUMBER.
- 5) PROVIDE MECHANICAL GROUND LUGS FASTENED TO BACK PANEL AND GROUNDED TO ENGINE-GENERATOR. GROUND ALL SHIELD DRAIN WIRES TO LUGS AT BACK PANEL ONLY.
- 6) PROVIDE WIRING HARNESSSES FOR CONNECTION TO GENERATOR AND TO ENGINE. INSTALL WIRES IN LIQUID TIGHT FLEX OR FLEXIBLE PLASTIC WIRE LOOM AND PROVIDE SERVICE LOOPS IN ACCORDANCE WITH SPECIFICATIONS.
- 7) SHOP TEST EACH NEW ENGINE-GENERATOR WITH ASSOCIATED JUNCTION BOX PERMANENTLY CONNECTED. UPON COMPLETION OF TESTING, COIL WIRING HARNESSSES AND SECURE JUNCTION BOX TO GENERATOR FOR SHIPPING.

**FIELD INSTALLATION NOTES:**

- 1) PERFORM ALL FIELD WIRING IN ACCORDANCE WITH SPECIFICATIONS. LABEL BOTH ENDS OF ALL FIELD WIRING WITH THE ENGINE PANEL TERMINAL NUMBER.
- 2) ON SHIELDED CONDUCTORS GROUND ALL SHIELD DRAIN WIRES AT ENGINE J-BOX ONLY. CLIP DRAIN WIRES AT OPPOSITE ENDS.

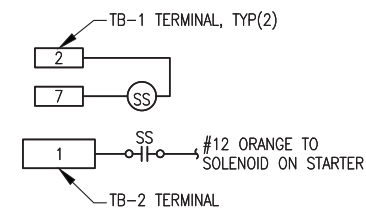

**6** STARTER AUX SOLENOID SS WIRING  
E3 NO SCALE

**7** EXHAUST RTD CONNECTOR  
E3 NO SCALE

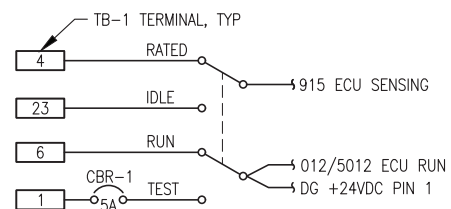

**8** TEST-IDLE/RUN-RATED SWITCH SW-TR WIRING  
E3 NO SCALE

ISSUED FOR  
GENERATOR  
PROCUREMENT  
JAN 2023

**ALASKA ENERGY AUTHORITY**

PROJECT: TENAKEE SPRINGS 2024 DERA POWER PLANT UPGRADE PROJECT

TITLE: 12VDC ENGINE CONTROL WIRING JUNCTION BOX

DRAWN BY: JTD	SCALE: AS NOTED
DESIGNED BY: CWV/BCG	DATE: 1/22/24
FILE NAME: TENADERA E1-E5	SHEET: E3
PROJECT NUMBER:	

P.O. 111405, Anchorage, AK 99511 (907)349-0100