



**This is not an order.**

INVITATION TO BID NUMBER (ITB)	<i>Return this bid to the issuing office below</i>
<p style="text-align: center;"><b>16049</b>  <b>Federal Express Fire Suppression</b>  <b>Detroit Diesel Engines Rebuild</b></p>	<p style="text-align: center;">Attention – Rich Wooten, Contract Compliance Specialist            Alaska Industrial Development and Export Authority            [AIDEA or the Authority]            813 West Northern Lights Boulevard            Anchorage, AK 99503-2495  <a href="mailto:rwooten@aidea.org">rwooten@aidea.org</a>, Ph. 907-771-3019 Fax 907-771-3044</p>

This bid is according to AIDEA procurement regulations 3AAC 100.010 – 3 AAC 100.900.

**Table of Contents**

Cover Sheet	1-page
Instructions to Bidders	4-pages
Appendix A. Terms and Conditions	4-pages
Appendix C. Overview and Specifications	3-pages
Appendix D. Bid Schedule	1-page
Appendix E. Attachments	105-pages
Debarment Certificate	1-page

**Invitation to Bid Schedule**

Bid Issued	September 2, 2015
Bid Opening	ITB shall be publically opened at, 2:00 p.m. September 23, 2015, in the Willow Conference Room.

**Important**

Interested firms shall register online to receive addenda and other information at <http://www.aideaaeprocmnt.org/>

AIDEA may provide periodic e-mail notices regarding addenda or clarifications regarding this bid to those companies who reply.

All addenda and other notices will be posted and available at <http://www.aidea.org/> “Quick Links” Procurement Opportunities.

## Instructions to Bidders

### 1. Invitation to Bid (ITB) Review

Bidders shall carefully review this ITB for defects and questionable or objectionable material. Bidders' comments concerning defects and questionable or objectionable material in the ITB must be made in writing and received by AIDEA's Procurement Department at least five (5) days before the bid opening date. This will allow time for an addendum if one is required. It will also help prevent the opening of a defective bid that will be rejected, and risk exposure of Bidders' prices. All correspondence will be addressed to the purchasing authority listed on the front of this ITB.

### 2. Bid Forms/Submittals

Bidders shall use and return the forms supplied with this invitation in submitting their bid. A photocopied bid can be submitted. **Bidders must return a signed copy of the Bid Schedule, and any/all required support documentation requested in this ITB.** The apparent low bidder may be required to provide additional documentation after bid opening and prior to award to assure compliance with all terms and conditions of the solicitation.

### 3. Minimum Qualifications - The Authority requires the following:

- a) Bidders shall be able to troubleshoot, and provide all of the parts, labor, expertise, and warranty required to perform the work described herein.
- b) If asked, Bidder must be able to provide examples of 3-projects similar to the one described herein

### 4. Submitting Bids

Envelopes containing bids must be sealed, marked, and addressed as shown below. **DO NOT FAX YOUR BID.** Envelopes with ITB numbers annotated on the outside will not be opened until the scheduled date and time. Hand carried bids should be delivered to the receptionist at the front desk or to the Procurement Manager for processing. Failure to correctly submit a bid may result in it being unopened or rejected and returned to the bidder.

#### **Bidder's return Address**

Alaska Industrial Development and Export Authority  
813 West Northern Lights Blvd  
Anchorage, Alaska 99503  
ATTN: Rich Wooten, Contract Compliance Specialist  
ITB 16049 Engine Rebuilds  
Opening Date: 2:00 September 23, 2015

### 5. Modification and Withdrawal of Bids

A bidder may, without prejudice, modify or withdraw its bid by written request provided that such request is received by the Authority prior to the bid opening date and time.

### 6. Late Bids

Late bids are bids received after the time and date set for receipt of the bids; and late bids will not be accepted.

## **7. Offer Period**

Bids must remain valid for a period of 60-days unless otherwise specified in the Bid Schedule.

## **8. Firm, Unqualified and Unconditional Offer**

Bidders must provide enough information with their offer to constitute a definite, firm, unqualified and unconditional offer. To be responsive an offer must constitute a definite, firm, unqualified and unconditional offer to meet all of the material terms of the ITB. Material terms are those which could affect price, quantity, quality, or delivery. Also included as material terms are those which are clearly identified in the ITB and which, for reasons of policy, must be complied with at risk of bid rejection for non-responsiveness.

## **9. Prices**

The bidder shall state prices in the units of issue on this ITB. Prices quoted for commodities must be in U.S. funds and include applicable federal duty, brokerage fees, packaging, and transportation cost to the F.O.B. point so that upon transfer of title the commodity can be utilized without further cost. Prices quoted for services will be quoted in U.S. funds and include applicable federal duty, brokerage fee, packaging, and transportation cost so that the services can be provided without further cost. Prices quoted in bids must be exclusive of federal, state, and local taxes. If the bidder believes that certain taxes are payable by the Authority, the bidder may list such taxes separately, directly below the bid price for the affected item.

The Authority is exempt from Federal Excise Tax except the following:

- Coal - Internal Revenue Code of 1986 (IRC), Section 4121 - on the purchase of coal;
- "Gas Guzzler" - IRC, Section 4064 - on the purchase of low m.p.g. automobiles, except that police and other emergency type vehicles are not subject to the tax,
- Air Cargo - IRC, Section 4271 - on the purchase of property transportation services by air;
- Air Passenger - IRC, Section 4261 - on the purchase of passenger transportation services by air carriers.

## **10. Extension of Prices**

In case of error in the extension of prices in the bid, the unit prices will govern; in a lot bid, the lot prices will govern,

## **11. Federal Excise Tax**

Federal Excise Tax should not be included in the bid price(s), the Authority is exempt from Federal Excise Tax.

## **12. Suitable Materials, Etc.**

Unless otherwise specified, all materials, supplies or equipment offered by a bidder must be new per the attached specifications.

## **13. Supporting Information**

The Authority strongly desires that bidders submit all required technical, specification, and other supporting information with their bid, so that a detailed analysis and determination can be made, by the Procurement Manager, that the product offered meets the ITB specifications and that other requirements of the ITB have been met. However, provided a bid meets the requirements for a definite, firm, and unqualified or unconditional offer, the Authority reserves the right to request supplemental information from the bidder, after the bids have been opened, to ensure that the products offered completely meet the ITB requirements. The requirement for such supplemental information will be at the reasonable discretion of the Authority and may include the requirement that a bidder will

provide a sample product(s) or certification of compatibility of accessories or component parts with the specifications so that the Authority can make a first-hand examination and determination.

A bidder's failure to provide this supplemental information or the product sample(s), within the time set by the Authority, will cause the Authority to consider the offer non-responsive and reject the bid.

#### **14. Subcontractor(S)**

Within five (5) working days of notice, the apparent low bidder must submit a list of the subcontractors that will be used in the performance of the contract. The list must include the name of each subcontractor and the location of the place of business for each subcontractor.

#### **15. Notice of Intent to Award**

After the responses to this ITB have been opened, a tabulation of the bids will be prepared. This tabulation, called a Notice of Intent, serves two purposes. It lists the name of each company or person that offered a bid and the price bid. It also serves as notice of the Authority's intent to award a contract(s) to the bidder(s) indicated. A copy of the Notice of Intent will be sent to each company or person who responded to the ITB. Bidders, identified as the apparent low responsive bidders, are instructed not to proceed until a Purchase Order, Contract Award, Lease, or other form of notice is given by the Procurement Manager. A company or person who proceeds prior to receiving a Purchase Order, Contract Award, Lease, or other form of notice from the Procurement Manager does so without a contract and at his or her own risk.

#### **16. Filing a Protest**

A bidder may protest the award of a contract or the proposed award of a contract for supplies, services, or professional services. The protest must be filed in writing and include the following information: (1) the name, address, and telephone number of the protester; (2) the signature of the protester or the protester's representative; (3) identification of the contracting agency and the solicitation or contract at issue; (4) a detailed statement of the legal and factual grounds of the protest, including copies of relevant documents; and (5) the form of relief requested. Protests will be treated in accordance with AIDEA Regulations 3 AAC 100.570. A Protest based on alleged improprieties or ambiguities in a solicitation must be filed at least 10 days before the bid date of the bid or proposal, unless a later bid protest due date is specifically allowed in the solicitation. A Protest based upon alleged improprieties in an award of a contract or a proposed award of a contract must be filed within 10-days after a notice.

#### **17. Order Documents**

Except as specifically allowed under this ITB, an ordering agency will not sign any vendor contract. The Authority is not bound by a vendor contract signed by a person who is not specifically authorized to sign for the Authority under this ITB. The Authority's Contract Award is the only order document that may be used to place orders against the contract(s) resulting from this ITB.

#### **18. Bid Preparation Costs**

The Authority is not liable for any costs incurred by the bidder in bid preparation.

**19. 5 Percent Alaska Bidder's Preference - AS 36.30.321(a), and AS 36.30.990(25)**

In order to qualify for the Alaska Bidder Preference the bidder must:

- Hold a current Alaska business license and submit a bid under the name on their business license.
- Have maintained a place of business within the state staffed by the bidder or an employee of the bidder for at least six months immediately preceding the date of the bid.  
And, if the bidder is a:
  - Corporation, is incorporated in Alaska or are otherwise qualified to do business under the laws of the state.
  - Sole Proprietorship, the proprietor must be a resident of the state.
  - Limited Liability Company organized under AS 10.50, all members must be residents of the state.
  - Partnership under AS 32.05, 32.06, or 32.11, all partners must be residents of the state.
  - Joint Venture, the joint venture must be composed entirely of ventures that qualify as Alaska bidders.

## Appendix A - Terms and Conditions

### 1. **Compliance**

In the performance of a contract, the Vendor must comply with all applicable federal, state, and borough regulations, codes, and laws; and be liable for all required insurance, licenses, permits and bonds; and pay all applicable federal, state, and borough taxes.

### 2. **Suitable Materials, Etc.**

Unless otherwise specified, all materials, supplies or equipment offered by a bidder shall be new, unused, and of the latest edition, version, model or crop and of recent manufacture.

### 3. **No Assignment or Delegation**

The Vendor may not assign or delegate this contract, or any part of it, or have any right to any money to be paid under it, except with the written consent of the Contracting Officer. Conditioned assignments will be rejected.

### 4. **Force Majeure**

(Impossibility to perform) The Vendor is not liable for the consequences of any failure to perform, or default in performing, any of its obligations under this Agreement, if that failure or default is caused by any unforeseeable Force Majeure, beyond the control of, and without the fault or negligence of, the Vendor. For the purposes of this Agreement, Force Majeure will mean war (whether declared or not); revolution; invasion; insurrection; riot; civil commotion; sabotage; military or usurped power; lightning; explosion; fire; storm; drought; flood; earthquake; epidemic; quarantine; strikes; acts or restraints of governmental authorities affecting the project or directly or indirectly prohibiting or restricting the furnishing or use of materials or labor required; inability to secure materials, machinery, equipment or labor because of priority, allocation or other regulations of any governmental authorities.

### 5. **Contract Extension**

The Authority and the successful Vendor agree: (1) that any holding over of the contract excluding any exercised renewal options will be considered as a month-to-month extension, and all other terms and conditions shall remain in full force and effect; and (2) to provide written notice to the other party of the intent to cancel such month-to-month extension at least thirty (30) days before the desired date of cancellation.

### 6. **Default**

In case of default by the Vendor, for any reason whatsoever, the Authority may procure the goods or services from another source and hold the Vendor responsible for any resulting excess cost and may seek other remedies under law or equity.

### 7. **Disputes**

Any dispute arising out of this agreement shall be resolved under the laws of Alaska. Any appeal of an administrative order or any original action to enforce any provision of this agreement or to obtain any relief from or remedy in connection with this agreement may be brought only in the superior court for the State of Alaska.

### 8. **Severability**

If any provision of the contract is declared by a court to be illegal or in conflict with any law, the validity of the remaining terms and provisions will not be affected; and, the rights and obligations of the parties will be construed and enforced as if the contract did not contain the particular provision held to be invalid.

**9. Continuing Obligation of Vendor**

Notwithstanding the expiration date of a contract resulting from this ITB, the Vendor is obligated to fulfill its responsibilities until warranty, guarantee, maintenance and parts availability requirements have completely expired.

**10. Human Trafficking**

By signature on their bid, the bidder certifies that the bidder is not established and headquartered or incorporated and headquartered in a country recognized as Tier 3 in the most recent United States Department of State's Trafficking in Persons Report. The most recent United States Department of State's Trafficking in Persons Report are located at the following website: <http://www.state.gov/q/tip/>; and failure to comply with this requirement will cause the state to reject the bid as non-responsive, or cancel the contract.

**11. Payment for State Purchases**

Payment for agreements under \$500,000 for the undisputed purchase of goods or services provided to a state agency will be made within 30 days of the receipt of a proper billing or the delivery of the goods or services to the location(s) specified in the agreement, whichever is later. A late payment is subject to 1.5% interest per month on the unpaid balance. Interest will not be paid if there is a dispute or if there is an agreement that establishes a lower interest rate or precludes the charging of interest.

**12. Shipping Damage**

The Authority will not accept or pay for damaged goods. The Vendor must file all claims against the carrier(s) for damages incurred to items in transit from the point of origin to the ultimate destination. The Authority will provide the Vendor with written notice when damaged goods are received. The Authority will deduct the cost of the damaged goods from the invoice prior to payment. The Vendor must file all claims against the carrier(s) for reimbursement of the loss.

**13. Indemnification**

The Vendor shall indemnify, hold harmless, and defend the contracting agency from and against any claim of, or liability for error, omission or negligent act of the Vendor under this agreement. The Vendor shall not be required to indemnify the contracting agency for a claim of, or liability for, the independent negligence of the contracting agency. If there is a claim of, or liability for, the joint negligent error or omission of the Vendor and the independent negligence of the Contracting agency, the indemnification and hold harmless obligation shall be apportioned on a comparative fault basis. "Vendor" and "Contracting agency", as used within this and the following article, include the employees, agents and other Vendors who are directly responsible, respectively, to each. The term "independent negligence" is negligence other than in the Contracting agency's selection, administration, monitoring, or controlling of the Vendor and in approving or accepting the Vendor's work.

**14. Insurance**

Without limiting Vendor's indemnification, it is agreed that Vendor shall purchase at its own expense and maintain in force at all times during the performance of services under this agreement the following policies of insurance. Where specific limits are shown, it is understood that they shall be the minimum acceptable limits. If the Vendor's policy contains higher limits, the Authority shall be entitled to coverage to the extent of such higher limits. Certificates of Insurance must be furnished to the contracting officer prior to beginning work and must provide for a notice of cancellation, non-renewal, or material change of conditions in accordance with policy provisions. Failure to furnish satisfactory evidence of insurance or lapse of the policy is a material breach of this contract and shall be grounds for termination of the Vendor's services. All insurance policies shall comply with, and be issued by insurers licensed to transact the business of insurance under AS 21.

**Proof of insurance is required for the following:**

Workers' Compensation Insurance: The Vendor shall provide and maintain, for all employees engaged in work under this contract, coverage as required by AS 23.30.045, and; where applicable, any other statutory obligations including but not limited to Federal U.S.L. & H. and Jones Act requirements. The policy must waive subrogation against the Authority.

Commercial General Liability Insurance: covering all business premises and operations used by the Vendor in the performance of services under this agreement with minimum coverage limits of \$300,000 combined single limit per occurrence.

Commercial Automobile Liability Insurance: covering all vehicles used by the Vendor in the performance of services under this agreement with minimum coverage limits of \$300,000 combined single limit per occurrence.

Failure to supply satisfactory proof of insurance within the time required will cause the Authority to declare the bidder non-responsible and to reject the bid.

**15. Insurance Certificate**

Shall name the Authority and the grantee as certificate holders and reference the contract number.

**16. Delivery Confirmation**

Bidders must obtain confirmation from manufacturers that the items offered are scheduled for production in sufficient time to meet the scheduled delivery dates.

**17. Billing Instructions**

Invoices will be addressed Alaska Industrial Development and Export Authority, 813 West Northern Lights Boulevard, Anchorage, AK 99503-2495; or emailed to [aideapayables@aidea.org](mailto:aideapayables@aidea.org). Vendor will reference the contract number on all invoices and correspondence. It is customary for AIDEA to make payment within 30-days of receipt of the merchandise or service, and the Vendor's invoice. Direct all billing questions to the Contracting Officer.

**18. Alterations**

The Contracting Office must approve in writing any Vendor alterations to the specifications prior to the changes. The Authority will not pay for alterations that are not pre-approved in advance and in writing by the Contracting Officer.

**19. Liquidated Damages**

Shall not apply to this procurement.

**20. Packaging**

The cost of all packaging must be included in the price bid. All packaging must be new and suitable for shipment and short-term warehouse storage.

**21. Warranty**

Provide warranty in accordance with the Specifications.

**22. Workmanship & Materials**

All work shall be performed in a thorough and competent manner and in accordance with current industry practices. The Vendor is responsible for the quality of the finished item. The Authority will reject any item that does not meet the specifications and return them to the Vendor. Vendors shall accept all rejected items at the Vendor's risk and expense.



**23. Contract Cancellation**

The Authority reserves the right to cancel any contract awarded as a result of this solicitation if; 1) the Vendor fails to properly perform the duties set out herein, 2) due to budget/funding issues, or 3) at its convenience upon 60 calendar days written notice to the Vendor. In the event of cancellation at its convenience, the Authority will pay for any disassembly and shipping charges necessary to remove the machine and return it to the nearest in State dealer.

**24. Brand and Model Offered**

Unless otherwise specified, when brand names and model numbers identify the type and quality of the goods desired, bidders must clearly indicate the brand names and model numbers they intend to provide. The bidder's failure to identify the brand and model offered will cause the Authority to consider the offer non-responsive and reject the bid.

**25. Order Documents**

Except as specifically allowed under this ITB, an ordering agency will not sign any vendor contract. The Authority is not bound by a vendor contract signed by a person who is not specifically authorized to sign for the Authority under this ITB. The Authority Contract Award is the only order document that may be used to place orders against the contract(s) resulting from this ITB.

**26. Compliance with ADA**

Services or activities furnished to the general-public on behalf of the Authority must be fully accessible. This is intended to ensure that agencies are in accordance with 28 CFR Part 35 Section 35.130 and that services, programs or activities furnished to the public through a contract do not subject qualified individuals with a disability to discrimination based on the disability.

The Authority complies with Title II of the Americans with Disabilities Act of 1990. Individuals with disabilities who may need auxiliary aids, services, and/or special modifications to participate in this procurement should contact Enterprise Technology Services at one of the following numbers no later than November 10, 2011 to make any necessary arrangements.

***Telephone: 907-465-5758, Fax: 907-465-3450, TDD: 907465-5745***

## APPENDIX C. OVERVIEW AND SPECIFICATIONS

### 1. Scope of Services

#### Project Scope of Work

Complete, rebuild, and replacement of parts; 6-each Detroit Diesels model 70647312, 341 HP Diesel engines for the Federal Express (FedEx) hanger fire suppression building (the "Project") located in Anchorage, Alaska. Contractor shall only be able to work on 1 engine at a time.

The Contractor who is awarded this contract, shall provide the following services: Perform all work necessary to completely rebuild an engine, according to Detroit Diesel specifications, for engines over 10,000 hours, which includes, but may not be limited to:

1. All repair or replacement parts must be Detroit Diesel manufactured or approved parts.
2. Disassemble, inspect for wear and defects, and chemically clean all parts and subassemblies (including engine block). Perform major in-frame service.
3. Completely overhaul and/or replace the following with new or remanufactured (not used) components: turbocharger, fuel modulator, water pump, governor, oil pump, fuel injectors; include replacement of pistons, rods, liners, cylinder heads.
4. Replace cylinder heads with remanufactured units, including new seals, valves, springs, guides and keepers.
5. Measure, magnaflux and inspect camshaft. Check for straight and, if needed, turn camshaft according to Detroit Diesel factory specifications. Polish camshaft. For any damage or wear discovered beyond this specification, the Contractor shall submit a Condition Found Report (CFR) and a full report of damage as prepared by a certified grinder, and/or certified machine shop, and/or Contractor to the AIDEA representative. If damage or wear can be repaired by grinding, then Contractor shall be responsible to grind the camshaft to acceptable Detroit Diesel specifications.
6. Measure, magnaflux and inspect crankshaft. Check crankshaft for straight and, if needed, turn crankshaft according to Detroit Diesel factory specifications. Polish crankshaft. For any damage or wear discovered beyond this specification, the Contractor shall submit a CFR and a full report of damage as prepared by a certified grinder, and/or Certified Machine Shop, and/or Contractor to the AIDEA representative. If damage or wear can be repaired by grinding, then Contractor shall be responsible to grind to the first or second undersize (or acceptable Detroit Diesel specifications).
7. Remove connecting rods and replace them with new or remanufactured Detroit Diesel connecting rods.
8. Disassemble, clean, pressure test and reseal oil cooler.
9. Replace oil filters with new. Clean and inspect oil filter bypass valves.
10. Replace vibration damper with new.
11. Replace all engine bearings, cam bearings and cylinder kits with new components.
12. Replace all gaskets, seals, hoses and fasteners with new components as per the Detroit Diesel parts manual for this engine. Any gaskets, hoses, seals and fasteners that are unique to this engine need to be replaced in kind.

13. Replace all engine oil lines and rubber fuel lines with new.
14. Replace starter with remanufactured unit.
15. Replace magnet 24V switch with new.
16. Replace alternator (100 amp, 24V) with new or remanufactured unit.
17. Replace thermostats with new.
18. Replace exhaust manifolds with new.
19. The after-cooler core needs to be sent out to be cleaned and pressure tested.
20. Replace fuel pump with new.
21. Replace electrical sensors per manufacturer's specifications. Sensors that are to be replaced that are unique to each engine are as follows:
  - Engine Oil Pressure, 1 ea.
  - Intake Manifold Pressure, 1 ea.
  - Coolant Temperature, 1 ea.
  - Engine Oil Temperature, 1 ea.
  - Exhaust Temperature, 1 ea.
  - Engine Oil Pressure, 1 ea.
  - Crankcase Pressure, 1 ea.
22. Replace starter ring gear with new.
23. Dynamometer test, for 2 hours, to determine engine meets factory specifications. Provide written summary of test results to AIDEA's representative.
24. Clean and paint engine's exterior as per Detroit Diesel Paint Specifications with Detroit Diesel Gray Exact Match Engine Enamel.
25. Remove or replace one (1) main engine air filter with new.

### **Deliverables**

- a. The engine rebuild will be performed on six Detroit Diesel, model 70647312, 341 HP diesel engines, currently located just north of the FedEx Hanger on Postmark Road, Anchorage, Alaska. These engines are in service powering fire pumps for the FedEx Hanger with over 10,000 operating hours. These engines shall be rebuilt, one at a time. Upon completion of each rebuilt and dynamometer tested engine the contractor may begin the next engine rebuild.
- b. All bidders must be capable of performing this type of work on Detroit Diesel, continuous duty and fire rated diesel engines.
- c. All work must meet or exceed Detroit Diesel specifications.
- d. All components of this rebuild (fasteners, hoses, belts, mechanical components, etc.) will be the responsibility of the Contractor at the Contractor's expense, and must be of the highest quality available to the industry as per Detroit Diesel manufacturer specifications.
- e. All repair/replacement parts must be Detroit Diesel manufactured or approved parts.

- f. The engine rebuild is to incorporate all design changes and engine updates as currently suggested by Detroit Diesel.
- g. The use of new or remanufactured parts depends on warranty and price, subject to prior approval by AIDEA.
- h. A detailed breakdown of all of parts and labor is required prior to payment of any invoice.
- i. Upon completion of the rebuild, the Contractor shall run the engine on a dynamometer, certified for the rated horsepower of the engine, for 2 hours, or to the satisfaction of AIDEA's representative.
- j. The Contractor shall provide AIDEA's representative with a written report of the dynamometer test results.
- k. Upon completion of the rebuild, the engine will be reinstalled.
- l. If a condition is found that warrants attention, it shall be brought to AIDEA's attention through a CFR. The Contractor shall submit the CFR to AIDEA for consideration. The CFR shall include, but not be limited to, a breakdown of the cost for repair; parts and labor must be two separate line items. AIDEA will meet with the Contractor to discuss the condition found, and the Contractor will provide the written cost estimate and time required to address the additional work. Upon approval by AIDEA of the price and time requirements to address the additional work, the Contractor may then proceed with the changed work. If Contractor performs any additional work without prior authorization, AIDEA is not obligated to pay for the additional work.
- m. Warranty. The rebuilt engine must be warranted to be free from defects in parts supplied by the vendor and free from defects in workmanship, under conditions of normal use and maintenance, for a Period of 1-YEAR FROM THE DATE THE ENGINE IS PLACED INTO SERVICE.

**Schedule**

The completion date for these engine rebuilds is July 30, 2016, unless otherwise approved by AIDEA. The contractor shall provide AIDEA with monthly updates on the rebuilds.

**APPENDIX D. BID SCHEDULE**

1. **Bid Submittals**
  - Appendix D – Bid Schedule
  - Debarment Certification
  - Insurance certificate shall be required from the successful Bidder.
2. **Inspection** - The work may be inspected by the Authority’s representative at the Bidder’s fabrication facility during the repair process.
3. **Work Location** – Work shall be performed on site at the FedEx hangar fire suppression building.
4. **F.O.B. Point** – is **FedEx Hanger Fire Suppression Building**
5. **Pricing** - The bid schedule requires a lump sum bid price. The price includes all costs and profit associated with furnishing the work described herein.
6. **Method of Award** - An award shall be made the low responsive and responsible bidder in the aggregate based on the lowest total price.

**7. Bid Schedule**

Line	Description	Quantity	Unit Cost	Lump Sum
1.	Rebuild Detroit Diesel Engines	6-each	\$	\$

**8. Acknowledge all addenda**

Addendum No	Date Issued	Addendum No	Date Issued	Addendum No	Date Issued

**9. Bidder Certification**

BIDDER’S NOTICE: By signature on this form, the Bidder certifies that:

- a. The price(s) submitted are independent and without collusion.
- b. The Bidder will comply with the laws of the State of Alaska;
- c. The Bidder will comply with applicable portions of the Federal Civil Rights Act of 1964;
- d. The Bidder will comply with the Equal Employment Opportunity Act and the regulations issued there under by the State and Federal Government; and
- e. The Bidder has reviewed all terms and conditions in this Invitation to Bid.

If any Bidder fails to comply with any of these requirements, the Authority may reject its bid, terminate the contract, or consider the Vendor in default.

Company Submitting Bid	Telephone Number
Address	Fax Number
Authorized Signature	E-mail Address
Print Name	Alaska Business License number DATE: _____

# Operation and Maintenance Instructions Manual

## DDFP SERIES ENGINES FOR FIRE PUMP APPLICATIONS

This manual covers Detroit Diesel engines  
modified by Clarke DD-A  
for fire pump service



## ABBREVIATIONS

AC	Alternating Current
AEC	Automatic Engine Controller
API	American Petroleum Institute
CCW	Counter-clockwise engine rotating (front view)
CDD-A	Clarke Detroit Diesel-Allison
CW	Clockwise engine rotation (front view)
DC	Direct Current
DDC	Detroit Diesel Corporation
DDFP	Detroit Diesel Engines approved for Fire Pump Service as certified by FM/UL/ULC for Clarke Detroit Diesel-Allison
FM	Factory Mutual Research
GM	General Motors Corporation
ID	Identification
IP	Instrument Panel
I-53	In-Line Cylinder arrangement 53 Series DDC Engine
I-71	In-Line Cylinder arrangement 71 Series DDC Engine
NA	Naturally Aspirated
NC	Normally Closed
NO	Normally Open
NFPA	National Fire Protection Association
P/N	Part Number
PSI	Pounds Per Square Inch
PTO	Power Take Off
RPM	Revolutions Per Minute
SAE	Society of Automotive Engineers
S/N	Serial Number
T	Turbocharged
TA	Turbocharged and Aftercooled
UL	Underwriters Laboratories Inc.
ULC	Underwriters Laboratories of Canada
V-92	Vee cylinder arrangement 92 Series DDC engines
V-71	Vee cylinder arrangement 71 Series DDC engines



# TABLE OF CONTENTS

SUBJECT	PAGE
ABBREVIATIONS.....	Inside Front Cover
DESCRIPTION — Section 1	
Principles of Operation .....	1
General Description .....	2
Model and Serial Number Designation .....	3
Engine Equipment .....	4
FM/UL Nameplate .....	5
General Specifications .....	6
OPERATING INSTRUCTIONS — Section 2	
Engine Start-Up and Operating Instructions .....	8
Standard Model Views .....	9
Electronic Speed Switch .....	10
Preventative Maintenance Schedule.....	11
ENGINE SYSTEMS — Section 3	
Fuel System — Section 3.1 .....	12
Operation.....	12
Maintenance & Service Procedures .....	15
Fuel System Schematic.....	14
Air Intake and Exhaust System — Section 3.2 .....	16
Air System Operation .....	16
Maintenance & Service Procedures .....	19
Exhaust Operation.....	19
Lubrication System — Section 3.3 .....	20
Operation.....	20
Lubricating System Schematics .....	21
Maintenance & Service Procedures .....	22
Cooling System — Section 3.4 .....	25
Operation.....	25
Maintenance & Service Procedures .....	30
Electrical System — Section 3.5 .....	31
Operation.....	31
Maintenance & Service Procedures .....	35
DC Wiring Diagram.....	37, 38
Engine Heater AC Wiring Diagram .....	39
Falk Drive Coupling Instructions — Section 3.6 .....	40
Installation Procedures .....	41
ENGINE TUNE-UP — Section 4	
Tune Up .....	46
TECHNICAL DATA — Section 5 .....	
47	
PARTS INFORMATION — Section 6	
Basic Engine Parts .....	48
Standard Option Parts .....	49
OWNER ASSISTANCE — Section 7 .....	
50, 51	
WARRANTY — Section 8 .....	
52, 53	
STORAGE — Section 9 .....	
54	
ALPHABETICAL INDEX — Section 10 .....	
55, 56	



## PRINCIPLES OF OPERATION

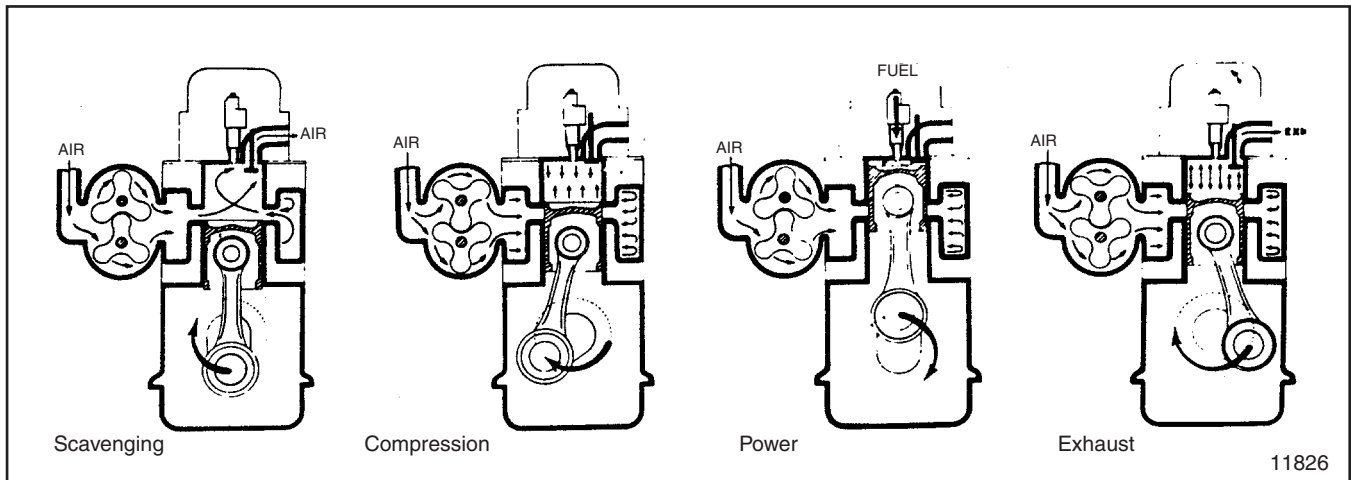

Fig. 1 - In-Line Cylinder Arrangement

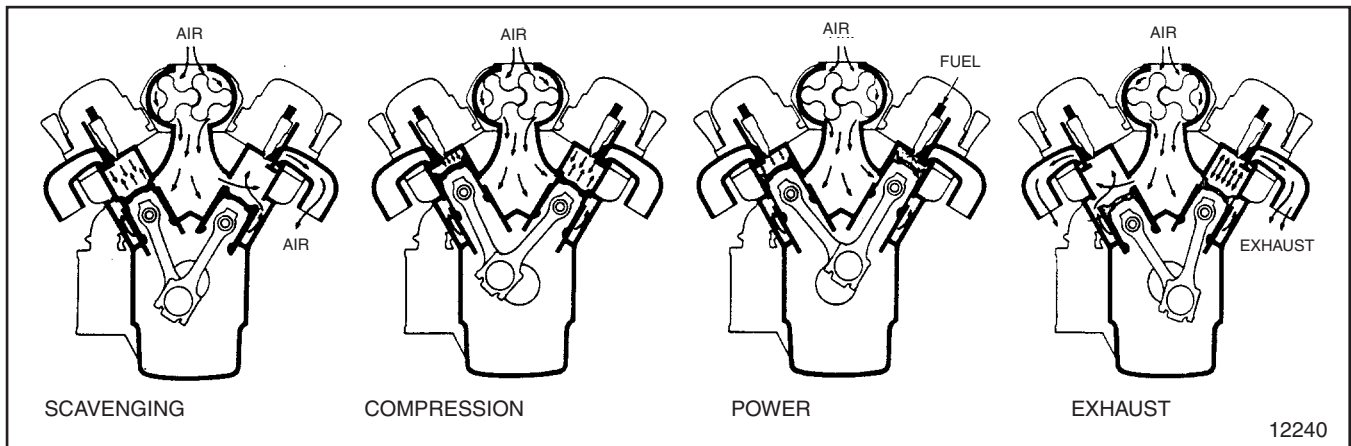

Fig. 2 - Vee Block Cylinder Arrangement

The diesel engine is an internal combustion power unit, in which the heat of fuel is converted into work in the cylinder of the engine.

In the diesel engine, air alone is compressed in the cylinder; then, after the air has been compressed, a charge of fuel is sprayed into the cylinder and ignition is accomplished by the heat of compression.

### The Two-Cycle Principle

In the two-cycle engine, intake and exhaust functions take place during part of the compression and power strokes respectively (Fig. 1) or (Fig. 2). In contrast, a four-cycle engine requires four piston strokes to complete an operating cycle; thus, during one half of its operation, the four-cycle engine functions merely as an air pump.

A blower is provided to force air into the cylinders for expelling the exhaust gases and to supply the cylinders with fresh air for combustion. The cylinder wall contains a row of ports which are above the piston when it is at the bottom of its stroke. These ports admit the air from the blower into the cylinder as soon as the rim of the piston uncovers the ports (Fig. 1 & 2 - Scavenging).

The unidirectional flow of air toward the exhaust valves produces a scavenging effect, leaving the cylinders full of clean air when the piston again covers the inlet ports.

As the piston continues on the upward stroke, the exhaust valves close and the charge of fresh air is subjected to compression (Fig. 1 & 2 - Compression).

Shortly before the piston reaches its highest position, the required amount of fuel is sprayed into the combustion chamber by the unit fuel injector (Fig. 1 & 2 - Power). The intense heat generated during the high compression of the air ignites the fine fuel spray immediately. The combustion continues until the fuel injected has been burned.

The resulting pressure forces the piston downward on its power stroke. The exhaust valves are again opened when the piston is about half way down, allowing the burned gases to escape into the exhaust manifold (Fig. 1 & 2 - Exhaust). Shortly thereafter, the downward moving piston uncovers the inlet ports and the cylinder is again swept with clean scavenging air. This entire combustion cycle is completed in each cylinder for each revolution of the crankshaft, or, in other words, in two strokes; hence, it is a "two-stroke cycle".

## DESCRIPTION

### Introduction

NFPA Pamphlet 20 states "The compression ignition diesel engine has proved to be the most dependable of the internal combustion engines for driving fire pumps." The diesel engine will operate under emergency power conditions where loss of utility or stand-by electric power renders electric motor driven pumps useless. The diesel driven fire pump system is preferred by most insurance companies.

This manual covers Detroit Diesel engines. These engines have been manufactured with specific options to function integrally with an automatic engine controller for stand-by fire protection service and to meet NFPA A-20 requirements. These systems are designed to function under emergency conditions and to assist in holding fire damage to a minimum. Complete understanding of the operation and maintenance of this fire protection system is essential to achieve this objective.

A separate manual covers the operation and maintenance of the Automatic Engine Controller (AEC).

The two-cycle engines covered in this manual are produced with various cylinder arrangements. The same bore and stroke and many of the major working parts such as injectors, pistons, connecting rods, cylinder liners and other parts are interchangeable within each engine series. The engines are either naturally aspirated (NA) or turbocharged (T) and some units are turbocharged and aftercooled (TA).

The engines have either an in-line or a vee type cylinder arrangements. The engine may have clockwise (CW) or counter-clockwise (CCW) rotation. Rotational reference is made from a front view of the engine to determine the rotation of the output shaft. All other engine references, (*right* or *left* side) are made from a rear view of the engine, looking at the flywheel.

All DDFP engines are Underwriters Laboratories (UL) listed, Underwriters Laboratories of Canada (ULC) listed and/or Factory Mutual (FM) approved and meet the requirements of the National Fire Protection Association (NFPA) standard 20.

Each engine is equipped with an oil cooler, lubricating oil filter, fuel filters, air cleaner, heat exchanger, starting motor, alternator, instrument panel and engine jacket water heater.

Full lubrication oil pressure is supplied to all main, connecting rod and camshaft bearings, and to other moving parts within the engine. A gear type pump draws oil from the oil pan through an intake screen, through the oil filter and then

to the oil cooler. From the oil cooler the oil enters a longitudinal oil gallery in the cylinder block where the supply divides and is channeled to the turbocharger (if included), to the cam and balance shaft end bearings and cylinder head, with the remainder going to the main bearings and connecting rod bearings via the drilled crankshaft. The oil then drains back into the oil pan.

Coolant is circulated through the engine by a centrifugal-type water pump. Heat is removed from the coolant as it circulates in a closed system through the heat exchanger. Control of the engine temperature is accomplished by a thermostat which regulates the flow of the coolant within the cooling system. Raw water from the fire pump passes through a tube bundle in the heat exchanger to remove the heat from the engine coolant.

Fuel is drawn from the supply tank through a strainer by a gear-type fuel pump. It is then forced through a filter and into the fuel inlet gallery in the cylinder head and to the injectors. Excess fuel is returned to the supply tank through the fuel outlet gallery and connecting lines. Since the fuel is constantly circulating through the injectors, it serves to cool the injectors and purges the system of air.

Air for scavenging and combustion is supplied by a blower which pumps air into the engine cylinders via the air box and cylinder liner ports. All air entering the blower first passes through an air cleaner. Turbochargers, when included, are located between the air cleaner and the blower. Some engines also include an after cooler which cools the air prior to entering the cylinders.

Engine starting is usually provided by an electric starting system. The electric starting motor is energized by a storage battery. A battery-charging alternator, with a built-in voltage regulator, serves to keep the battery charged while the unit is running. At rest, a battery charger in the AEC keeps batteries charged.

Engine speed is regulated by a mechanical type engine governor with a tamper proof speed control device.

### Model Numbering & Identification

Two model numbers are shown on this product. First is the Clarke FM/UL/ULC approved model number showing the prefix *DDFP*. Figure 3 explains the identification system on *DDFP* units. Second is the DDC basic engine model number using eight digits. Figure 4 provides details for understanding the significance of each digit.

The DDFP model number appears on the FM/UL/ULC tag attached to the right rear of the engine flywheel housing. The DDC basic engine model number appears on the engine rocker cover. The engine S/N should be the same at both locations.

On some engines, you may find different engine rated horsepower and operating RPM on the rocker cover name plate than on the FM/UL/ULC tag attached to the flywheel housing. The FM/UL/ULC tag is the official power data and takes precedence over the rocker cover data.

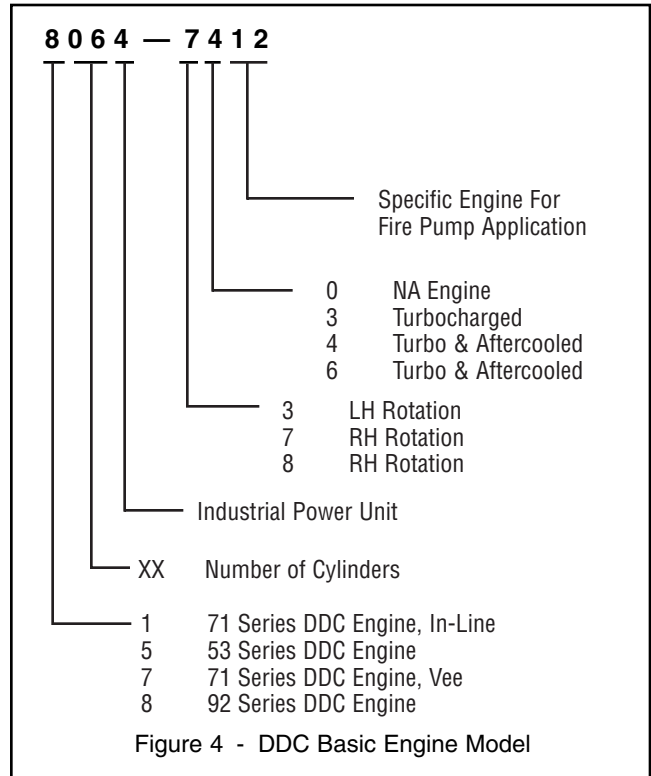
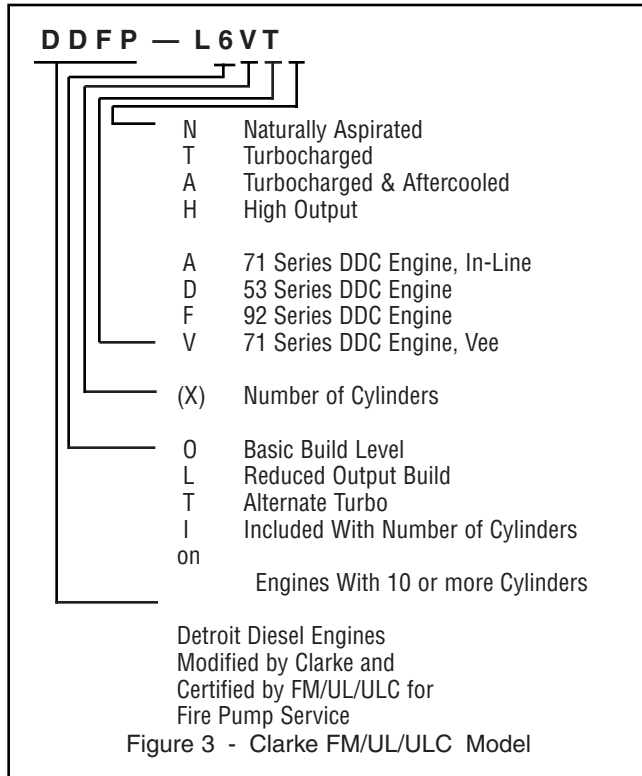

(See Page 1)

---

**DDFP STANDARD ENGINE EQUIPMENT LIST**

- Air cleaner, oiled gauze or dry type for protected environment.
- Battery charging alternator (12 or 24V-DC) negative ground
- Engine coolant heater with AC power connection (120, 208 or 240V)
- Engine oil cooler
- Electric starting motor (12 or 24V-DC)
- Exhaust manifold insulation or heat shield
- Fuel inlet check valve
- Fuel filters - Primary and Secondary
- Governor speed control (10% No Load to Full Load)
- Heat Exchanger with pressure cap
- High water temperature switch
- Instrument panel with water temperature, oil pressure and voltmeter
- Junction box (DC control) for connection to engine controller
- Low oil pressure switch
- Manual over-ride of automatic operations including instruction plate
- Manual start contactors - two provided on each engine
- Oil filter(s) full flow with by-pass
- Oil pan heater (optional)
- Overspeed control and reset switch
- Solenoid Run/Stop control-signal from AEC
- Direct mounted engine half of Falk coupling
- Tachometer with hour meter
- Tamper proof throttle control factory preset
- Wiring harness for DC control

## FM/UL/ULC CERTIFICATION NAME PLATE

The standard nameplate (Fig. 5) contains the following information: FM/UL certified model number; Clark e specification number; production date; rated horsepower; full load engine speed; basic engine serial number (S/N). The name plate is located on the right rear of the engine and attached to the flywheel housing.

The DDC model and S/N are found on the manufacturer's I.D. label (Fig. 6) on the v valve rocker cover. This model is also stamped on the engine block.

On the Inline engines, the model number is stamped into the cylinder block casting on a machined pad above and to the right of the engine blower. On the VEE engines, the number is stamped at the right front of the block just behind the water pump.

When requested, a ULC nameplate is provided in addition to the FM & UL nameplate. This plate is mounted separately on the engine.



Figure 5



Figure 6

<b>General Specifications - DDFP Models</b>				
<b>Type</b>	<b>03DN 03DT L3DT T3DT 2 Cycle</b>	<b>03AN 2 Cycle</b>	<b>04AN 04AT 2 Cycle</b>	<b>L6VT T6VT 2 Cycle</b>
Number of Cylinders	3	3	4	6
Bore (inches)	3.875	4.25	4.25	4.25
Bore (mm)	98	108	108	108
Stroke (inches)	4.5	5	5	5
Stroke (mm)	114	127	127	127
Compression Ratio (T Eng)	18.7:1	--	17:1	17:1
Compression Ratio (N Eng)	21.0:1	18.7:1	18.7:1	--
Total Displacement (cub. in.)	159	213	284	426
Total Displacement (liters)	2.61	3.49	4.66	6.99
Number of Main Bearings	4	4	5	4

<b>General Specifications - DDFP Models</b>						
<b>Type</b>	<b>06FA 2 Cycle</b>	<b>06FH 2 Cycle</b>	<b>L8FA 08FA 2 Cycle</b>	<b>08FH 2 Cycle</b>	<b>12FT 2 Cycle</b>	<b>12FH 2 Cycle</b>
Number of Cylinders	6	6	8	8	12	12
Bore (inches)	4.84	4.84	4.84	4.84	4.84	4.84
Bore (mm)	123	123	123	123	123	123
Stroke (inches)	5	5	5	5	5	5
Stroke (mm)	127	127	127	127	127	127
Compression Ratio	17:1	15:1	17:1	15:1	17:1	15:1
Total Displacement (cubic inches)	552	552	736	736	1104	1104
Total Displacement (liters)	9.05	9.1	12.07	12.07	18.1	18.1
Number of Main Bearings	4	4	5	5	8	8

For Specific Operational Data For Each Engine Model, Refer To Technical Data Section 5.

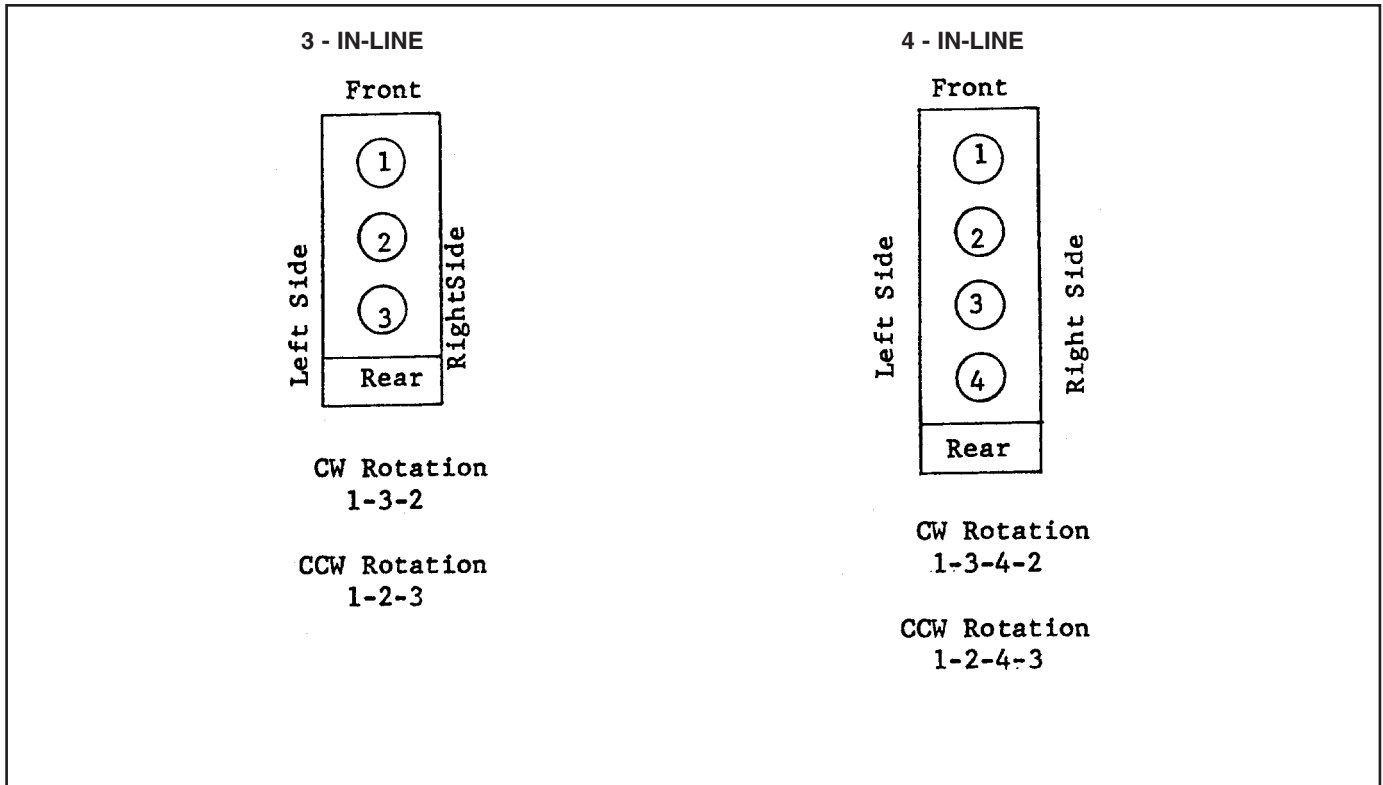

Fig. 7 - Cylinder Designation and Firing Order

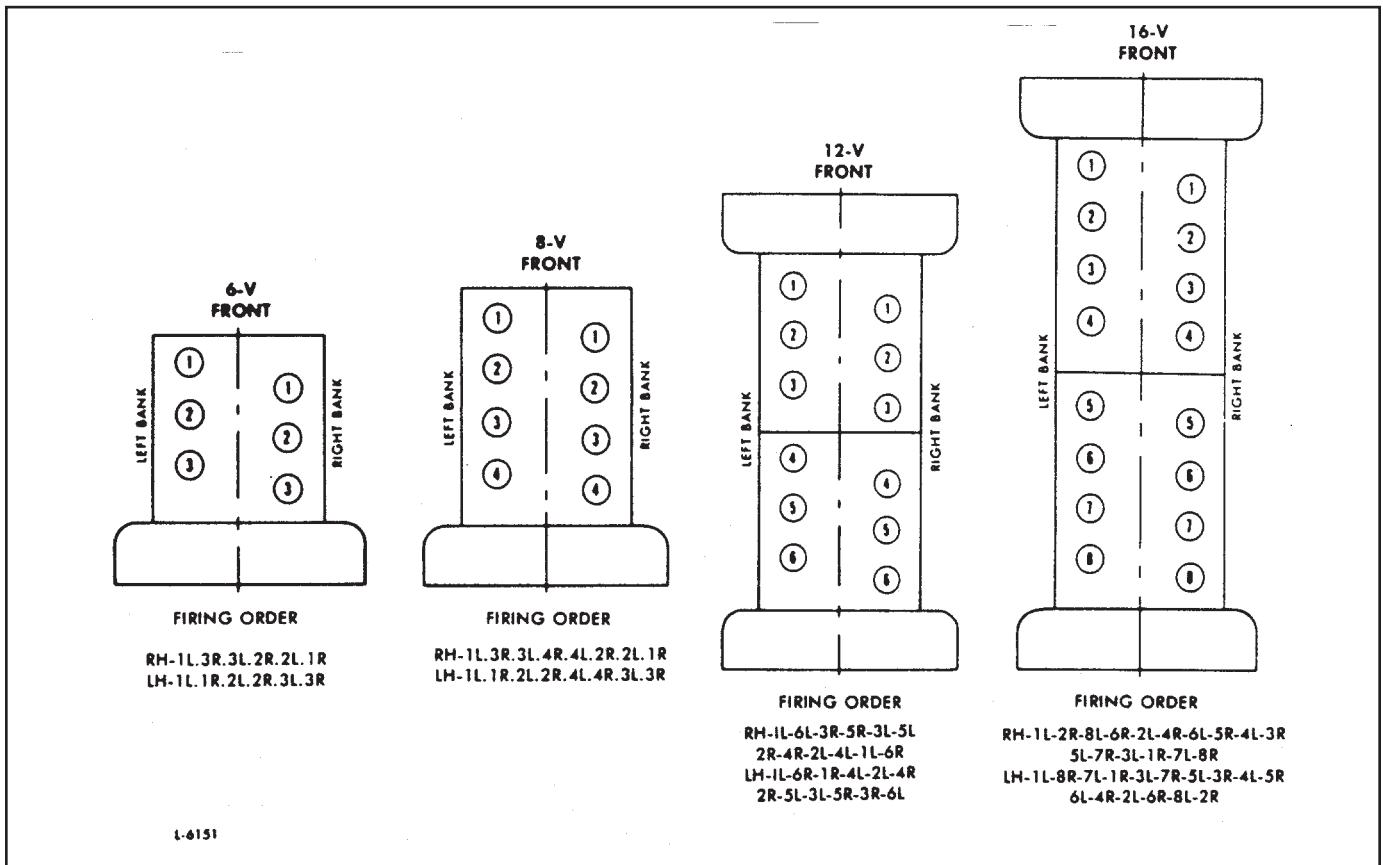

Fig. 8 VEE Engine Cylinder Designation and Firing Order

## ENGINE START UP AND OPERATING INSTRUCTIONS

### Preparing New Engine For Start-Up

Before starting a new or overhauled engine for the first time, carefully read and follow the check list below. Attempting to run the engine before studying these instructions may result in serious damage to the engine.

1. Make all electrical (DC) connections between engine (DC) junction box and engine controller.
2. Make all raw water connections to heat exchanger tank. Discharge line should be one size larger than supply line and rise a minimum of 3 inches above heat exchange outlet to assure complete coverage of the heat exchange core. Discharge water is to be piped to an open waste cone.
 

**NOTE:** Do not allow raw water plumbing to stress on engine heat exchanger.
3. Install all of the drain cocks or plugs in the cooling system (drain cocks are removed for shipping engines dry).
4. Fill engine cooling system with PRE-MIXED 50 percent water and 50 percent permanent type antifreeze solution. Fill to top heat exchanger tank.
 

**NOTE:** Refer to Section 3.4 for Cooling System Fill Procedure.
5. Connect fuel supply line and fuel return line to supply tank. Bleed fuel system of all air.
 

**NOTE:** Do not use galvanized material for any component part of a diesel fuel system. The fuel will chemically react with the zinc coating.
6. Fill fuel tank with No. 2 diesel fuel.
 

**NOTE:** No. 2 diesel fuel is the only recommended fuel, engine power could be affected by using any other type.
7. Fill engine crankcase with SAE 40 weight oil per oil recommendations of Section 3. Oil filler locations vary by engine model. Most will be found on the engine valve cover.
8. Pre-lubricate engine to a minimum 25 psi (172 KPA) to insure an immediate flow of oil to all bearings at the initial engine start-up. Contact the authorized DDC Distributor/Dealer if you require assistance with this item.

9. Unbox and inspect air cleaner element for damage or deterioration. Install air cleaner element on engine.

10. Install batteries, battery cables and service batteries as required by manufacturer. See battery recommendation under Section 3.

11. Install exhaust system. A vertical exhaust outlet is furnished for customer/contractor installation. A flexible exhaust connector must be installed at outlet.

**NOTE:** Do not exceed exhaust back pressure limits. See Section 5 for details for each engine model.

**NOTE:** Do not allow exhaust system plumbing to stress on engine.

If any problems or questions develop in performing the above procedures, advise the authorized DDC Distributor/Dealer of details when making arrangements for the installation inspection.

**NOTE:** Only one initial start-up inspection is provided at no charge for an installation review. Be sure to cover items 1-11 thoroughly before calling the authorized DDC Distributor/Dealer.

### Normal Running

Fire pump engines are run periodically to assure proper operation. Units may be run automatically as programmed within the AEC or they may be run manually for systems evaluation.

**NOTE:** For specific operating instructions, see Section 3 - Electrical System.

### Normal Care And Maintenance Should Be Made On The Following Systems:

#### Fuel System

Periodically check fuel tank to assure it is full. Keep the fuel tank filled to reduce condensation to a minimum and to assure full running time during emergency operation. Engine fuel filter should be changed annually or when fouled with contamination. If contaminated, locate the source and correct. (See Section 3 page 13 for proper procedure). If the engine runs out of fuel or if the engine is out of service for a considerable length of time, it may be necessary to reprime the fuel system. Refer to Section 3 for proper procedure.



### Drive Belts

Adjust the alternator drive belts as recommended under the Preventive Maintenance Section 2.

### Storage Battery

Check the batteries. The top should be clean and dry, the terminals tight and protected, and the electrolyte must be at the proper level. They should be tested weekly to determine the condition of cells, and the amount of charge.

**NOTE:** Once each week, check the batteries with a hydrometer; the corrected reading should be 1.265 or higher. Hydrometer readings should be corrected for the temperature of the electrolyte. Should a problem be detected, locate source and correct.

### Oil Pressure

Normal engine operating oil pressure is 40-70 psi (276-433 kPa). If operating pressure falls below 30 psi (206 kPa), stop engine and investigate cause.

### Coolant Temperature

When unit is not running, Jacket water heaters maintain

engine coolant between 120 -140 degrees F (49-60° C). When running, engine coolant temperature should register between 180-200 degrees F (82-93° C). See Section 3 for detailed information.

### Crankcase

The oil level should be maintained between the *Full* mark and *Low* mark. Check the oil level weekly prior to normal exercise. The oil dipstick is located on the right side of the engine. Do not check oil level when the engine is running. If the engine crankcase was refilled, stop the engine after normal operating temperature has been reached, allow the oil to drain back into the crankcase (approximately 10 minutes) and check the oil level. Add oil, if necessary, to bring it to the proper level on the dipstick.

**NOTE:** DO NOT OVER-FILL CRANKCASE.

Use only the recommended lubricating oil specified under Section 3 - Lubricating Oil.

### Running Inspection

While the engine is running at operating temperature, check for coolant, fuel or lubricating oil leaks. Tighten the line

### Standard Model Views

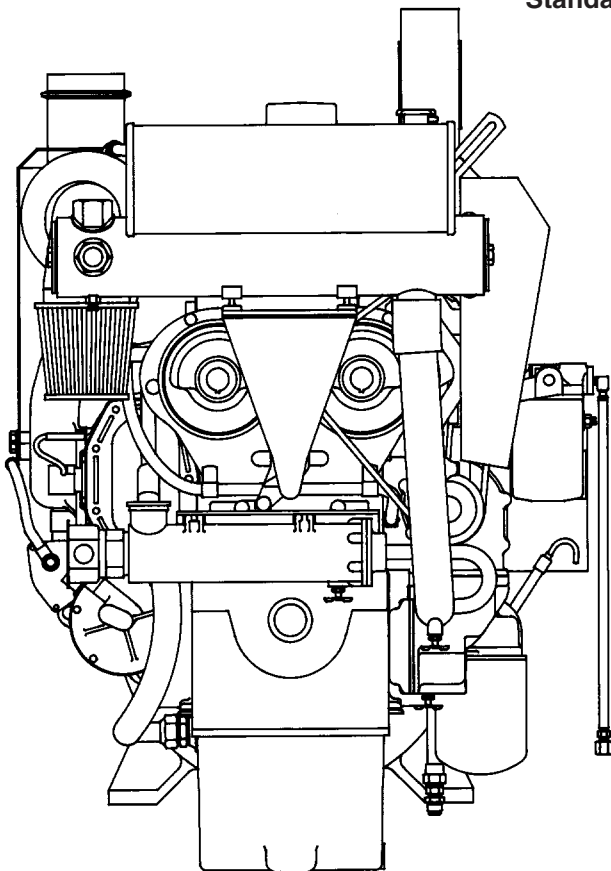

Front View (I-53)

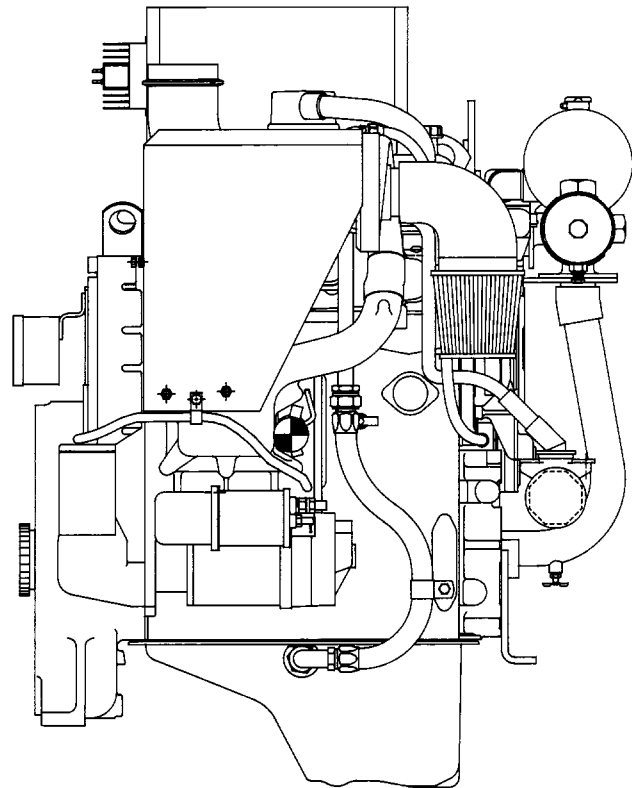

Right Side View (I-53)

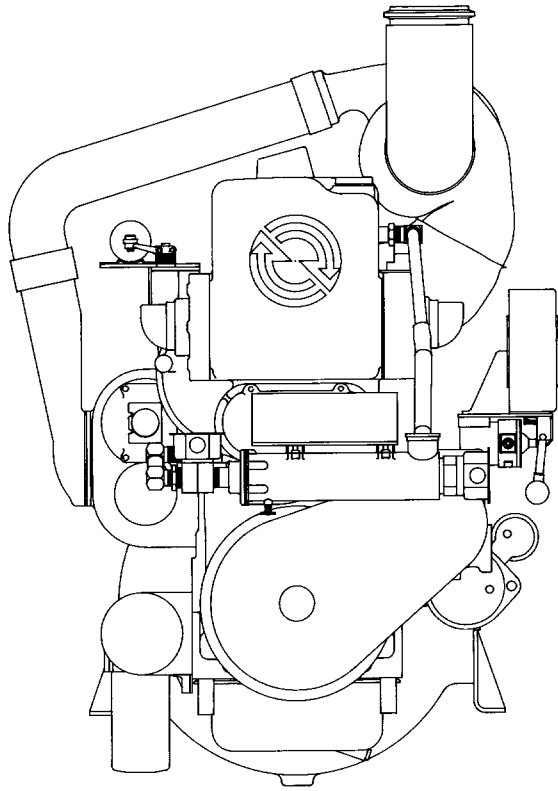

Front View (I-71)

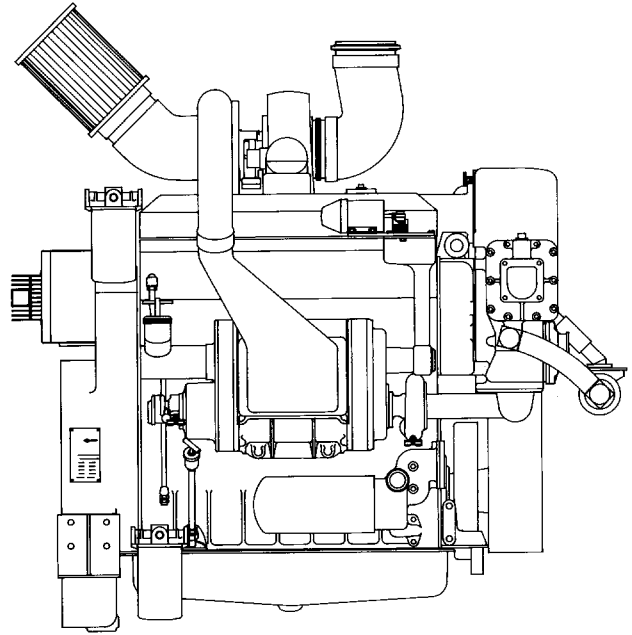

Right Side View (I-71)

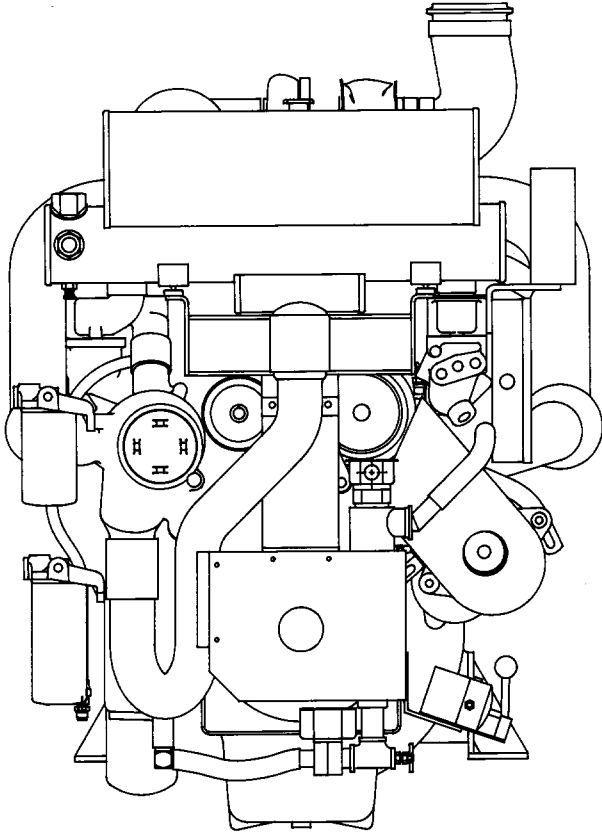

Front View (V-71)

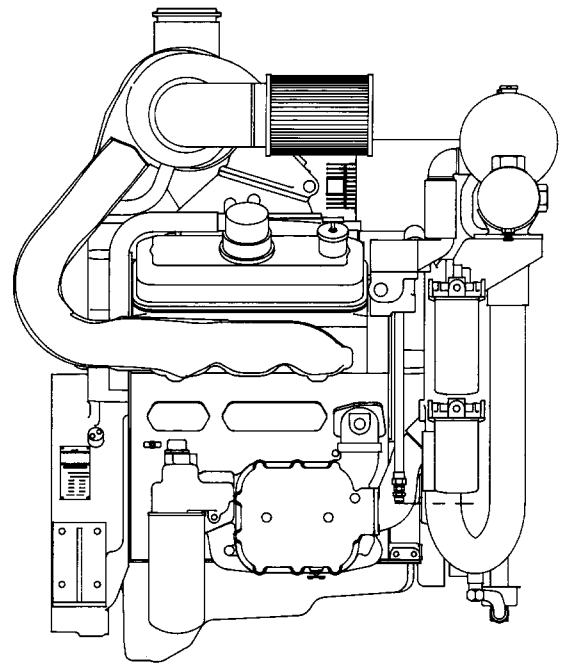

Right Side View (6V-71)

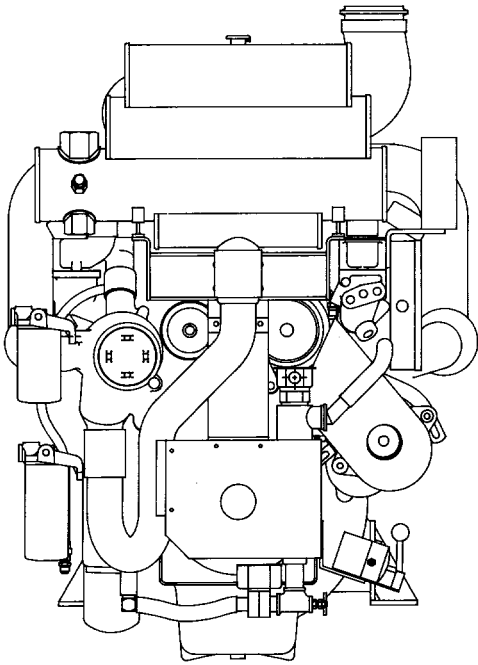

Front View (V-92)

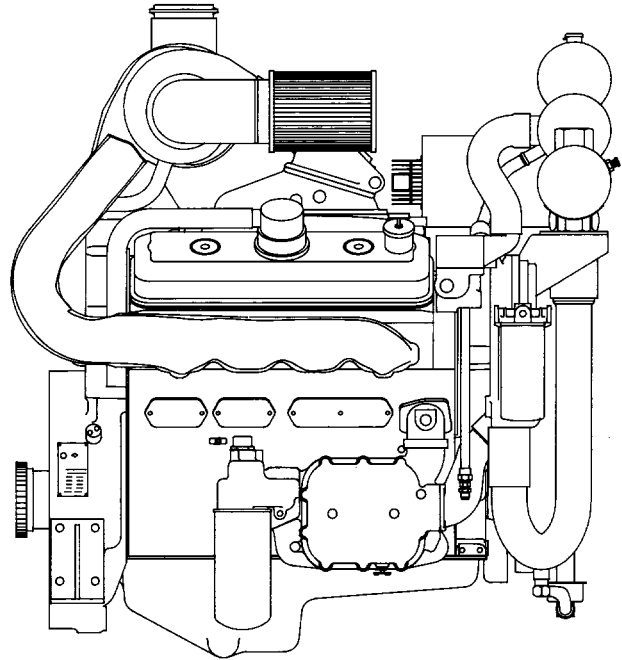

Right Side View (V-92)

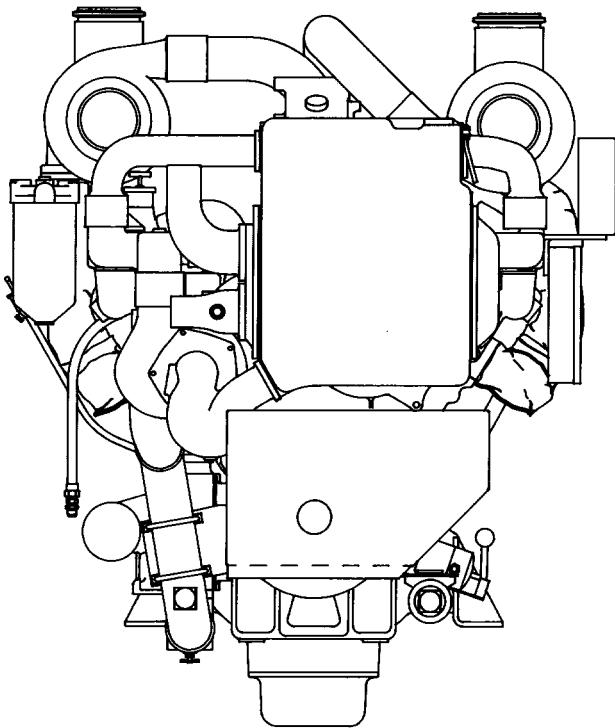

Front View (12V-92)

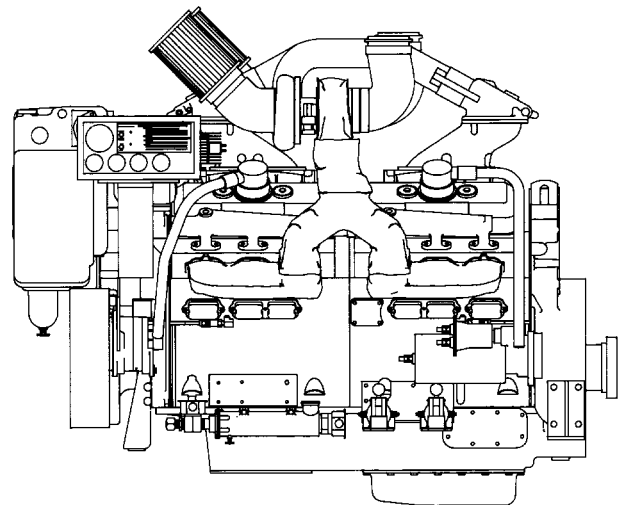

Left Side View (12V-92)

## ELECTRONIC SPEED SWITCH

The speed switch is located on the rear or back side of the instrument panel.

There are two (2) functions built into the speed switch. First to terminate starter cranking, once the engine is running. Second to signal the controller and effect an engine shutdown in the event of an engine overspeed condition.

Features of the speed switch are a "manual reset button" on the face of the switch, which must be pushed into reset the switch should the engine shutdown from an overspeed condition. Additionally, a verification circuit to assist in checking or setting the overspeed set point.

### CALIBRATION

Both crank terminate (SW#1) and overspeed (SW#2) set points, are set at the factory and should not require additional calibration. Adjustments can be made to the set points of SW#1 and/or SW#2 if required using a jewelers screw driver. Turning the corresponding adjustment screw CW to increase or CCW to decrease the set point. To access either adjustment screw remove the small cover plate on the face of the speed switch.

Crank terminate (SW#1) adjustment should be done reading "engine crankshaft" speed at the front of the engine using a hand held tachometer. For starter protection and optimum engine stability, this switch should be calibrated to 1000 RPM.

Overspeed (SW#2) adjustment should be done reading "engine crankshaft" speed at the front of the engine using a hand held tachometer. This switch should be calibrated to 120% of rated speed, but never higher than 3200 RPM. Refer to the stainless steel nameplate located at the right rear of the engine for the correct rated speed.

### OVERSPEED VERIFICATION

To verify the function of the overspeed signal (SW#2) without overspeeding the engine, install a jumper wire on terminals "C & D" of the speed switch. This will provide the controller with an overspeed signal and engine shutdown at 67% of calibrated RPM.

Start the engine via the controller, the speed switch will effect an overspeed signal and shutdown protecting both the engine and pump.

### EXAMPLE

Rated Speed : 2100 RPM  
Overspeed Shutdown : 2520 RPM (120% of 2100 RPM)  
Verification Shutdown : 1688 RPM (67% of 2520 RPM)

### CAUTION

After verification of SW#2 the jumper wire must be removed and the "reset button" pushed in to re-instate normal operation of the engine and speed switch.

## PREVENTIVE MAINTENANCE SCHEDULE

Item	Inspection Interval			
	Weekly	6 Months	1 Year	2 Year
1. Run Engine (per NFPA 20 Specifications)	X			
2. General Inspection	X			
3. Lubricating Oil	X		R	
4. Fuel Tank	X			
5. Fuel Lines		X		
6. Cooling System	X			R
7. Battery	X	C		
8. Air Cleaner - Dry Type (-03AN & -04AN)		X	R	R
- Oil Gauze (All Other Models)		X	C	R
9. Drive Belts		X		
10. Speed Control		X		
11. Fuel & Lube Oil Filters			R	
12. Exhaust System	X	X		
13. Battery Charging Alternator		X		
14. Manual Contractors		X		
15. Operating Gauges	X			
16. Crankcase Vent System			X	
17. Heat Exchanger Electrode				X
18. Governor Run-Stop Mechanism		X		
19. Jacket Water Heater	X			
20. Wiring System			X	
21. Coolant Hose Inspection	X			R

See Parts Information Section 6 for Lubricating Oil And Coolant Analysis' Kits

**IMPORTANT:** Set AEC to "of f" while servicing engine. Before turning the AEC to the "off" position, check with the maintenance and security supervisors to verify that all departments concerned will be alerted of the temporary interruption of their fire protection equipment for normal maintenance or testing. Also, alert the local fire department in the event that the AEC is connected by silent alarm to headquarters. When servicing is complete, return AEC selector to

"Automatic" position and the manual operating lever to "auto - off" position.

X Check  
R Replace  
C Clean

## ENGINE SYSTEMS

<b>Section 3.1</b>	<b>Fuel System</b>
<b>Section 3.2</b>	<b>Air Intake &amp; Exhaust System</b>
<b>Section 3.3</b>	<b>Lubrication System</b>
<b>Section 3.4</b>	<b>Cooling System</b>
<b>Section 3.5</b>	<b>Electrical System</b>
<b>Section 3.6</b>	<b>Falk Drive Coupling</b>

In this **Engine Systems** section that follows, data is presented in a generalized way for a description of system operation. For specific operational data and system limits, refer to Section 5. In addition to knowing the specific DDFP

model being operated, make special note of the certified engine operating speed (RPM). Much of the data varies by operating RPM - check the FM/UL/ULC certification tag on the engine flywheel housing for this speed.

### FUEL SYSTEM

#### OPERATION

Fuel is drawn from the supply tank through the fuel strainer and enters the fuel pump at the inlet side. Upon leaving the fuel pump under pressure, the fuel is forced through the fuel filter and into the fuel inlet manifold where it passes through fuel pipes into the inlet side of each fuel injector. The fuel is atomized through small injector spray tip orifices into the combustion chamber. Surplus fuel, returning from the injectors, passes through the fuel return manifold and connecting fuel lines back to the fuel tank. The continuous flow of fuel through the injectors helps to cool the injectors and to remove air from the fuel system.

#### CHECK VALVE

A check valve is installed between the fuel filter and the fuel inlet manifold. The check valve is rated to open at approximately 2 psi (13.7 KPA). The fuel tank and supply lines should be arranged to limit static pressure so that the valve remains closed when unit is not running. This valve opens automatically from fuel pump pressure when the unit starts. Refer to Figure 1, Page 14, for fuel system components.

#### FUEL INJECTOR

The fuel injector combines in a single unit all of the parts necessary to provide complete and independent fuel injection at each cylinder. The injector creates the high pressure necessary for fuel injection, meters the proper amount of fuel, atomizes the fuel, and times the injection into the combustion chamber.

Since the injector is one of the most important and carefully constructed parts of the engine, it is recommended that the injector be replaced as an assembly if it is not operating properly. An authorized DDC Distributor/Dealer is equipped to provide new and reconditioned replacement injectors. Under no circumstance should an attempt be made to repair these injectors. Genuine factory new or "reliable" injectors should be used for repairs.

#### FUEL PUMP

DDFP Engines are equipped with a positive displacement gear type fuel transfer pump. Fuel pumps are furnished in either left or right hand rotation according to the engine model, and are stamped *RH* or *LH*. These pumps are not interchangeable and cannot be rebuilt to operate in an opposite rotation. The fuel pump used on the 53 series engine is driven by the governor assembly on the left rear. On I-71 it is attached and driven off the rear of the lower engine blower rotor. On VEE engines, the pump is attached and driven off the right front blower rotor located on the vee of the block.

A spring-loaded relief valve, incorporated in the pump body, normally remains in the closed position, operating only when the pressure on the outlet side (to the fuel filter) becomes excessive due to a plugged filter or fuel line.

The fuel pump incorporates two oil seals. Two tapped holes are provided in the underside of the pump body, between the oil seals, to permit a drain tube to be attached. If fuel leakage exceeds one drop per minute, the seals must be replaced. An authorized DDC Distributor/Dealer is properly equipped to replace the seals or to provide reconditioned parts.

**SPIN-ON TYPE FUEL FILTER**

A spin-on type fuel strainer and fuel filter (Fig. 2) is used on Clarke DDFP engines. The spin-on filter cartridge consists of a shell, element and gasket combined into a unitized replacement assembly. No separate springs or seats are required to support the filters.

The filter base incorporates a threaded sleeve to accept the spin-on filter cartridges. The word "Primary" or "Secondary" is cast on the fuel strainer base for identification.

No drain cocks are provided on the spin-on filters. Where water is a problem, residue may be drained by removing and inverting the filter. Refill the filter with clean fuel oil before reinstalling it. Should water be found, locate the source and correct by draining or cleaning as required.

**Replace the Filter as Follows:**

1. Unscrew the filter (or strainer) and discard it.
2. Fill a new filter replacement cartridge full with clean fuel oil. Coat the seal gasket lightly with clean fuel oil.
3. Install the new filter assembly and tighten it to two-thirds of a turn beyond gasket contact.
4. Start the engine and check for leaks.

**NOTE:** DDFP engines have the "Primary" filter at or below the fuel pump. One exception to this is current production I-53 engines. Due to factory designed, formed steel fuel lines, the I-53 filters are mounted the reverse of all others. The Primary Filter mounts to the cylinder head above the pump. The Secondary filter mounts to the coolant water inlet elbow below the fuel pump. Inlet fuel check valves are always located on the discharge side of the secondary filter.

**DIESEL FUEL RECOMMENDATIONS**

The quality and grade of fuel used is a very important factor in obtaining satisfactory engine performance, long engine life, and acceptable exhaust emission levels. Certified engine ratings are based at standard SAE conditions using the recommended #2-D Diesel Fuel. Refer to the Diesel Fuel Specifications chart Fig 3 for verification of fuel properties. For additional information on the fuel system, see technical data Section 5, Page 43. In addition, Sulfur content of the #2 Diesel Fuel used must be limited to 0.5% mass. The com-

General Fuel Classification	ASTM Test	No. 2 ASTM 2-D
Gravity, °API #	D 287	33 - 37
Flash Point, Min. °F (°C)	D 93	125 (52)
Viscosity, Kinematic cST @ 100°F (40°C)	D 445	1.9 - 4.1
Sulfur Content wt%, Max.	D 1266	0.5
Carbon Residue on 10%, wt%, Max.	D 524	0.35
Accelerated Stability Total Insolubles mg/100 ml, Max. #	D 2274	1.5
Ash, wt%, Max.	D 482	0.01
Cetane Number, Min. +	D 613	45
Cetane Index, Min. +	D 4737	40
Distillation Temperature, °F (°C)	D 86	
IBP, Typical #		375 (191)
10% Typical #		430 (221)
50% Typical #		510 (256)
90% +		625 (329) Max.
End Point #		675 (357) Max.
Water & Sediment %, Max.	D 1796	0.05

# Not Specified in ASTM D 975 .....

+ Differs from ASTM D 975

Fig. 3 - Diesel Fuel Specifications Chart

## FUEL SYSTEM SCHEMATICS

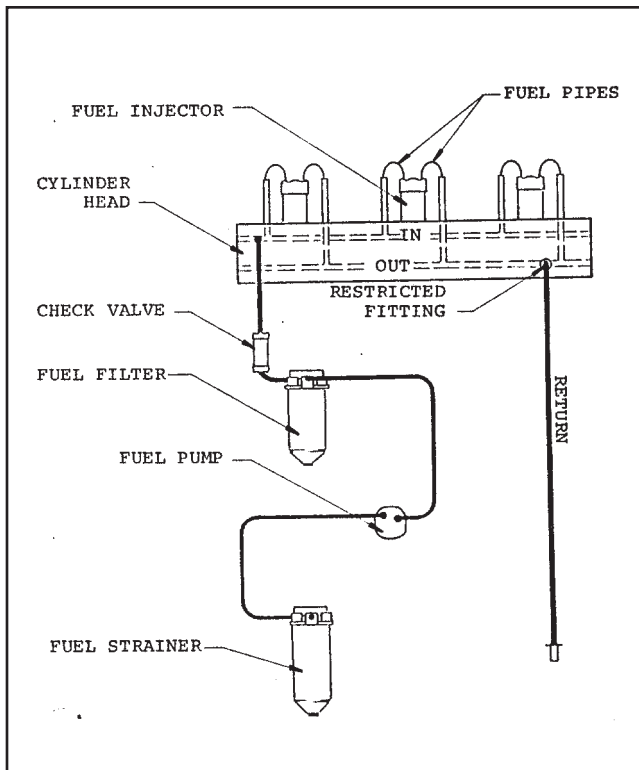

Fig. 1 - DDFP Fuel System

1. Fuel Strainer (Primary)
2. Fuel Transfer Pump
3. Fuel Filter (Secondary)
4. Check Valves
5. Cylinder Head with Internal Manifolds
6. Fuel Injectors
7. Fuel Pipes (Inlet and Return to Injector)
8. Restricted Fuel Fitting
9. Return to Tank

## ENGINE MECHANICAL GOVERNOR

A variable speed mechanical governor provides speed control of the engine. The certified engine speed, shown on FM/UL/ULC label, has been preset at the factory. Minor speed adjustments can be made in the field to meet specific installation condition, generally  $\pm 50$  RPM maximum.

The governor is controlled by the RUN-STOP solenoid. This solenoid is activated by a signal from the AEC. A manual over-ride switch on the instrument panel, placed in the **MANUAL** position, allows manual operation should the AEC malfunction.

**Note:** Always leave the instrument panel switch in the **AUTO** position when the unit is unattended.



## MAINTENANCE AND SERVICE PROCEDURES

### Weekly

- 1). Fuel Tank: Keep the fuel tank filled to reduce condensation to a minimum. Open drain at the bottom of the fuel tank once a week to drain off any possible water and/or sediment. Fill tank after each test run.

**NOTE:** Per NFPA 20 standards, the fuel tank level must never be less than 50% of capacity.

- 2). Fuel: Use a proper grade of #2-D diesel fuel only.

### 6 Months

Check condition of fuel lines for fraying, leaks or poor condition. Replace as necessary.

### Yearly

Change primary and secondary fuel filters. Refer to Section 6 for recommended part numbers.

## DIESEL FUEL CONTAMINATION

The most common form of diesel fuel contamination is water. Water is harmful to the fuel system and it also promotes the growth of microbiological organisms (microbes). These microbes clog fuel filters with a "slime" and restrict fuel flow.

Water can be introduced into the fuel supply through poor maintenance (loose or open fuel tank caps), contaminated fuel supply or condensation.

Condensation is particularly prevalent on units which stand idle for extended periods of time, such as fire pump units. Ambient temperature changes cause condensation in partially filled fuel tanks.

Water accumulation can be controlled by mixing isopropyl alcohol (dry gas) into the fuel oil at a ratio of one pint per 125 gallons fuel (or 0.10% by volume).

Microbe growth can be eliminated through the use of commercially available biocides. There are two basic types on the market. The water soluble type treats only the tank

where it is introduced. Microbe growth can start again if fuel is transferred from a treated to an untreated tank. Diesel fuel soluble type, such as "Biobor" manufactured by U.S. Borax or equivalent, treats the fuel itself and therefore the entire fuel system. Please follow manufacturer's recommendations on usage of these materials.

### Engine Out of Fuel

The problems of restarting an engine that has run out of fuel involves the entire fuel system. After the fuel is exhausted from the fuel tank, fuel is then pumped from the primary fuel strainer and sometimes partially removed from the secondary fuel filter before the fuel supply becomes insufficient to sustain engine firing.

To ensure prompt starting and smooth running, the fuel system must be purged of air and full of fuel from the supply tank to the restricted fitting at the fuel return line. To accomplish this, a manual priming pump, such as tool P/N J5956 or an electrical type priming pump can be adapted easily to the fittings provided on the secondary filter. To be sure the injectors are lubricated, priming through the secondary filter is preferred. The system should be primed until no air is present in the fuel flow from the return line. Pressure should not exceed 15 psi (103kPa) for ease of handling and safety reasons.

Priming is not always necessary if the filter elements are filled with fuel when installed and the fuel manifolds in the head are not drained of fuel. Prolonged use of the starter motor and engine fuel pump to prime the system can result in damage to the starter, fuel pump, injectors and erratic running of the engine, due to the amount of air in the lines and filters from the supply tank to the cylinder head.

**NOTE:** Under no circumstances should a starting aid such as ether be used to run the engine until the fuel system is primed. Injector damage will occur if this method is used. The heat generated by the external fuel source will cause the tips to be damaged when the fuel cools them. The

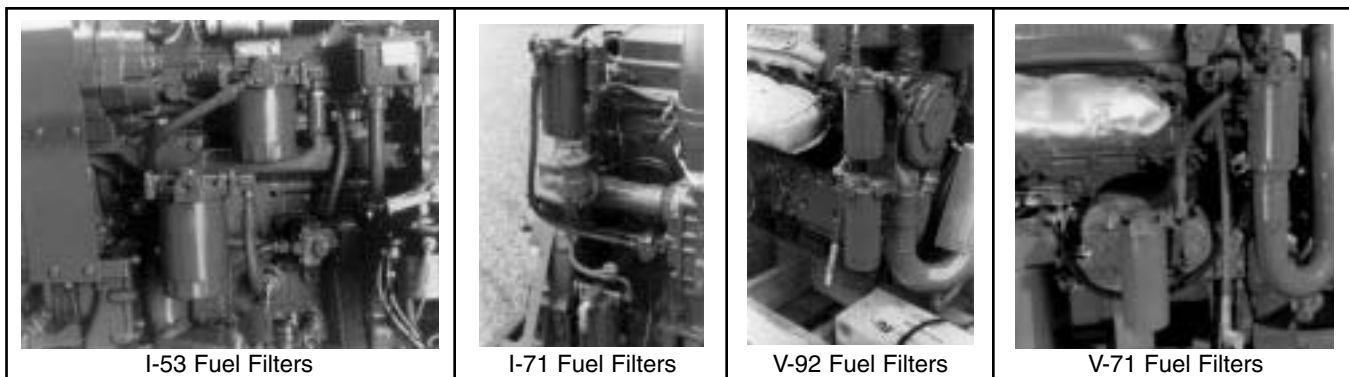

Figure 2

## AIR INTAKE AND EXHAUST SYSTEM

### AIR INTAKE OPERATION

In the scavenging process employed in the engines, a charge of air is forced into the cylinders by the blower and thoroughly sweeps out all of the burned gases through the exhaust valves. This air also helps to cool the internal engine parts, particularly the exhaust valves. At the beginning of the compression stroke, therefore, each cylinder is filled with fresh, clean air which provides for efficient combustion.

The air, entering the blower from the air cleaner, is picked up by the blower rotor lobes and carried to the discharge side of the blower as indicated by the arrows in Figure 1 & 2, Page 1. The continuous discharge of fresh air from the blower enters the air chamber of the cylinder block and sweeps through the intake ports of the cylinder liners.

The angle of the ports in the cylinder liners creates a uniform swirling motion to the intake air as it enters the cylinders. This motion persists throughout the compression

### AIR CLEANER

The air cleaner used on DDFP engines is either a dry type or the reusable type. Should a situation occur where the air cleaner becomes plugged with dirt (starving the engine for air), low power and heavy black smoke will be the result; the air cleaner should be serviced immediately.

**CAUTION:** Do not attempt to remove the air cleaner while an engine is running nor run the engine while the air cleaner is off. Exposed turbocharger could cause severe injury to personnel and major internal engine damage could occur should any foreign matter be drawn into the engine.

The air cleaner manufacturer recommends the following:

1. On engines using dry elements, replace the air cleaner element.
2. On engines with pre-oiled elements, service with a special oil. These elements can be serviced or replaced. Part number is shown in the parts section of this manual.
3. When servicing the element is not practical, you can improve filter efficiency by re-spraying with oil.

**NOTE:** Do not attempt this while engine is running.

**NOTE:** Do not over oil.

## AIR FILTER SERVICE INSTRUCTIONS

<p><b>1. PRE-CLEANING</b></p> <p>Tap the element to dislodge any large embedded dirt, then gently brush with a soft bristle brush. <i>(Note: If complete cleaning is not practical at this time, re-oil the element and re-install in your vehicle.)</i></p> 	<p><b>2. SPRAY ON CLEANER</b></p> <p>Spray <b>K&amp;N</b> air filter cleaner liberally onto the entire element and let soak for 10 minutes.</p> 	<p><b>3. PAN CLEANING</b></p> <p>Large <b>K&amp;N</b> elements can be rolled or soaked in a shallow pan of <b>K&amp;N</b> air filter cleaner. Remove immediately and let soak for approximately 10 minutes.</p> 
<p><b>4. CLEANING HINTS</b></p> <p>Use only <b>K&amp;N</b> air filter cleaner.</p> <p><b>NO gasoline cleaning.</b>  <b>NO steam cleaning.</b>  <b>NO caustic cleaning solutions.</b>  <b>NO strong detergents.</b>  <b>NO high pressure car wash.</b>  <b>NO parts cleaning solvents.</b></p> <p>Any of these NO's can cause harm to the cotton filter media, plus shrink and harden the rubber end caps.</p>	<p><b>5. RINSE OFF</b></p> <p>Rinse off the element with low pressure water. Tap water is OK. Always flush from the clean side to dirty side. This removes the dirt and does not drive it into the filter.</p> 	<p><b>6. DRYING HINTS</b></p> <p>Always dry naturally. After rinsing, shake off all excess water and let the element dry naturally.</p> <p><b>DO NOT USE COMPRESSED AIR</b>  <b>DO NOT USE OPEN FLAME</b>  <b>DO NOT USE HEAT DRYERS</b></p> <p><b>EXCESS HEAT WILL SHRINK THE COTTON FILTER MEDIA.</b></p> <p><b>COMPRESSED AIR WILL BLOW HOLES IN THE ELEMENT.</b></p>
<p><b>7. AEROSOL OILING</b></p> <p>After cleaning air filter always re-oil before using. <b>Spray</b> <b>K&amp;N</b> air filter oil down into each pleat with one pass per pleat. Wait 10 minutes and reoil any white spots still showing.</p> 	<p><b>8. SQUEEZE BOTTLE OILING</b></p> <p>After cleaning air filter always re-oil before using. Squeeze <b>K&amp;N</b> air filter oil down into the bottom and along each pleat — only one pass per pleat. Let oil wick into cotton for 20 minutes. Re-oil any white spots still showing.</p> 	<p><b>9. OILING HINTS</b></p> <p>Never use a <b>K&amp;N</b> air filter without oil. <i>(The filter will not stop the dirt without the oil.)</i> Use only <b>K&amp;N</b> formulated air filter oil.</p> <p><b>K&amp;N</b> air filter oil is a compound of mineral and animal oil blended with special polymers to form a very efficient tack barrier. Red dye is added to show just where you have applied the oil. Eventually the red color will fade but the oil will remain and filter the air.</p> <p><b>NEVER USE Automatic Transmission Fluid.</b>  <b>NEVER USE Motor Oil.</b>  <b>NEVER USE Diesel Fuel.</b>  <b>NEVER USE WD-40, LPS, or other light weight oils.</b></p>

Figure 1 - Air Filter Service Instructions

### AIR BOX DRAINS

During normal engine operation, water vapor from the intake air, as well as a slight amount of fuel and lubricating oil fumes, condenses and settles on the bottom of the air box. This condensation is removed by the air box pressure through air box drain tubes mounted on the side of the cylinder block.

Liquid accumulation in the air box will result if a drain tube becomes plugged. Remove the drain tubes and connectors from the cylinder block and clean them thoroughly when necessary.

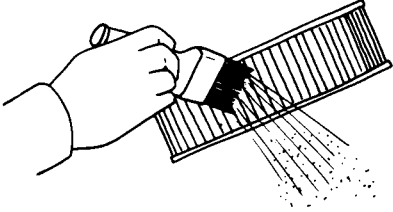
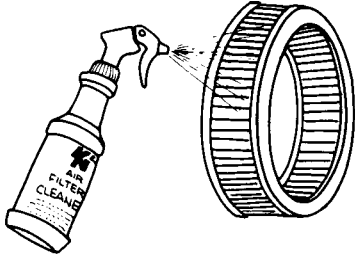
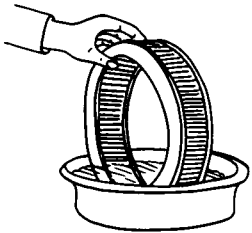
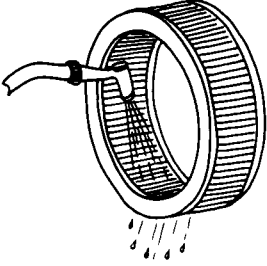
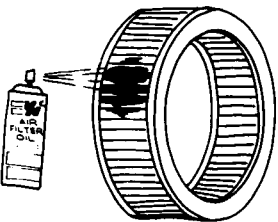
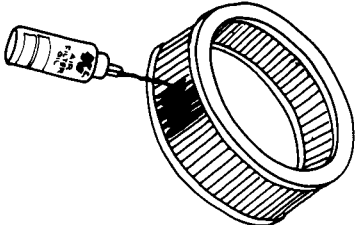
### CRANKCASE VENTILATION

Harmful vapors which may form within the engine are removed from the crankcase, gear train, and injector compartments by a continuous, pressurized ventilation system.

ments by a continuous, pressurized ventilation system.

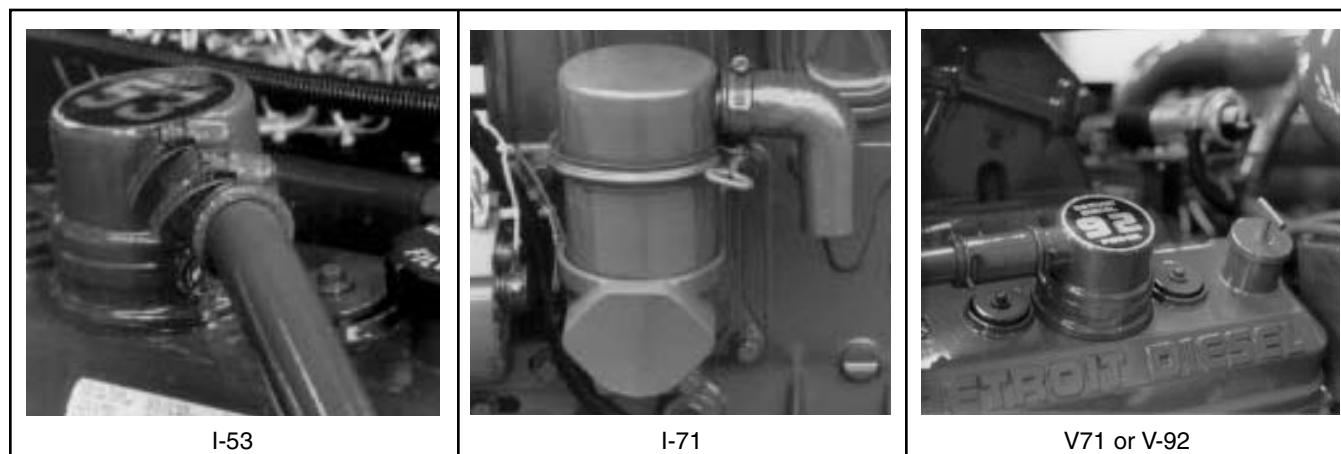

Figure 2 - Crankcase Ventilation

A slight pressure is maintained within the engine crankcase and injector compartment. This crankcase pressure and resulting ventilation is accomplished by the air seepage past the piston rings sweeping up through the flywheel housing and/or the balance weight cover into the valve and injector

rocker arm compartment. Here it is expelled through a vent pipe attached to the rocker cover breather assembly. Turbocharged I-71 engines additionally use a breather attached to the front left side of the cylinder block. Figure 2 shows the vent system for each engine series.

## EXHAUST OPERATION

Internal combustion engines convert fuel energy into both useful work and wasted heat. The useful work is the fly-wheel rotation that drives the pump. The wasted heat involves the engine water cooling system, radiated heat and the exhaust gases. Approximately  $\frac{2}{3}$  of the fuel energy is wasted. Critical review must be made of these systems to assure that the engine delivers the useful power required and maintains the engine within the operating parameters established by the engine manufacturer.

The exhaust system is critical to the proper engine performance. When initially installed, consideration must be given to the exhaust gas flow requirements, the exhaust temperatures and the exhaust back-pressure limitations of the specific engine. Generally, N engines can tolerate a higher exhaust pressure than T engines. Refer to Section 5 for specific engine model and operating speed back-pressure limitations. All the components in an exhaust system contribute to the back-pressure determination including the flexible exhaust section, muffler, exhaust piping and its configuration. In addition to providing engine exhaust data and back-pressure limitations, Clarke offers a service to installers, through the local Pump OEM Dealer, for making recommendations on exhaust system sizing for specific installations.

## MAINTENANCE AND SERVICE PROCEDURES

### Weekly

Prior to each maintenance run make a visual check of the exhaust system to verify condition of piping and muffler (if used). Investigate thoroughly any areas that would appear to have rusty conditions such as rain water running down pipe and getting inside the engine. Severe internal engine damage could occur.

Inspect the engine air cleaner for dirt buildup or damage.

During actual maintenance run check engine crankcase ventilation tube for excessive blow-by or pressure.

### 6 Months

Inspect exhaust system for leaks or plugging, if any are found, repair immediately. Inspect and tighten if necessary exhaust manifold, turbo mount (if equipped) and piping bolts/nuts. NFPA 37 requirements are to have the exhaust system covered with high temperature insulation for personnel protection. Inspect the insulation condition for any deterioration or looseness, repair as necessary.

Exhaust system back pressure limits are not to be exceeded.

If the exhaust system should become restricted, the hot exhaust gases cannot escape from the engine. This condition would cause a loss of power, extreme internal engine heat, and very high exhaust gas temperatures. These conditions can and will cause internal cylinder damage and a reduction of engine life.

Some engines are turbocharged (T). Turbochargers increase the air flow into the engine cylinder and permit increased horsepower by burning more fuel than is possible in a naturally aspirated (N) engine. Turbochargers enhance the efficiencies of engines and add power to a similar displacement (N) engine.

Basically, turbochargers are maintenance free. However, should any exhaust manifold studs or bolts break or come loose, engine exhaust gases can start leaking into the pump room. Under these conditions, the engine should be attended to immediately. First indications of an exhaust leak would be the smell of diesel exhaust and possible eye irritation. Unless fire pump maintenance personnel are well versed in a repair of turbochargers and exhaust systems, contact your local Distributor/Dealer for assistance.

**NOTE:** Exhaust back pressure, air inlet restriction and crankcase pressure limits are listed for each DDFP Model in Technical Data Section 5. These limits are not to be exceeded. To properly check these limits, the engine must be producing maximum required horsepower.

While the engine is running inspect exhaust pipe outlet outside of the pump room itself for environmental hazards such as excessive smoke conditions. The following could be used as a guide for general engine operating conditions.

1. Blue Smoke — Possible engine oil consumption - too many areas to list for possibilities.
2. White Smoke — Possibility of water in cylinders  
Source — Possible water in fuel or internal engine problem.

Should any of these or any other conditions be found, contact your local DDC Distributor/Dealer for assistance. Check condition of the air inlet system ducting clamp tightness hose condition.

### Yearly

Clean and re-oil the air cleaner element per the manufacturers directions. Each engine is shipped with the cleaning instructions. Refer to Figure 1, page 17.

Check crankcase ventilation tube for proper operation by making a visual inspection while engine is running.

## LUBRICATION SYSTEM

### OPERATION

The lubricating oil system is schematically illustrated in Figures 1, 2 and 3 for the Inline and VEE engines. The system consists of an oil pump, oil cooler, a full-flow oil filter, by-pass valves at the oil cooler and filter, and pressure regulator valves at the pump and in the cylinder block main oil gallery. Positive lubrication is ensured at all times by this system.

Oil for lubricating the connecting rod bearings, piston pins, and for cooling the piston head, is provided through the drilled hole in the crankshaft from the adjacent forward main bearings. The gear train is lubricated by the overflow of the oil from the camshaft pocket through a connecting passage into the flywheel housing from the camshaft, balance shaft, and idler gear bearings. The blower drive gear bearing is lubricated through an external pipe from the rear horizontal oil passage of the cylinder block.

On the Inline engines the oil from the cam pocket enters the blower and overflows through two holes, one at each end of the blower housing, providing lubrication for the blower drive gears at the rear end and for the governor mechanism at the front. On the VEE engines, the blower drive gear is lubricated from the rear of the blower.

### LUBE OIL PUMP

The positive displacement gear type pump is mounted to the main bearing caps on I-71 and driven from the front end of the crankshaft. On the I-53, V-71 and V-92 engines the pump is found in the lower front cover and driven by the front end of the crankshaft. The I-71, V-71 and V-92 have a pressure relief located on the discharge side of the pump, which maintains pressure being delivered to the oil filter and cooler. The I-53 engine does not use a pressure relief valve but does incorporate the use of the filter and oil cooler bypass valve to maintain pressure.

All four engines use an oil pressure regulator valve to maintain oil gallery minimum pressures. See technical data Section 5 for specifics per engine model.

### OIL COOLER

All engines use a plate type oil cooler. Between each engine model, the major difference lies in the number of plates in each cooler. The number of plates required is determined by engine horsepower developed. All the oil cooler systems incorporate oil bypass valves in the event of plate core plugging.

It should be understood that improper engine maintenance could adversely effect the efficiency of the oil cooler system. Please refer to the technical data Section 5, for specific lube oil temperature and engine coolant temperature ranges for each engine model.

### LUBE OIL FILL

On I-71 engines, the oil fill is located on the right rear. On the VEE engines, it is found in the right bank valve rocker cover. On the 53 Series engine, the oil fill is also located on the rocker cover. See technical data, Section 5 for oil volumes and specifications on each engine model. A typical oil fill location is shown in Figure 5, Page 24.

### OIL LEVEL DIPSTICK

On most DDFP engines, the dipstick is located on the lower left side. Exceptions are the I-71 and 12V92 models where the dipstick is located on the right. Oil level can be checked only when the engine is at rest (not running). Oil levels must be maintained between the low and full marks.

**NOTE:** Due to the basic engine design, DDC engines retain large volumes of oil in the block while running. For this reason, proper oil level cannot be checked immediately after engine shut off. Wait approximately 10 minutes before checking oil level. Do not add oil to a running engine; overfilling can occur!

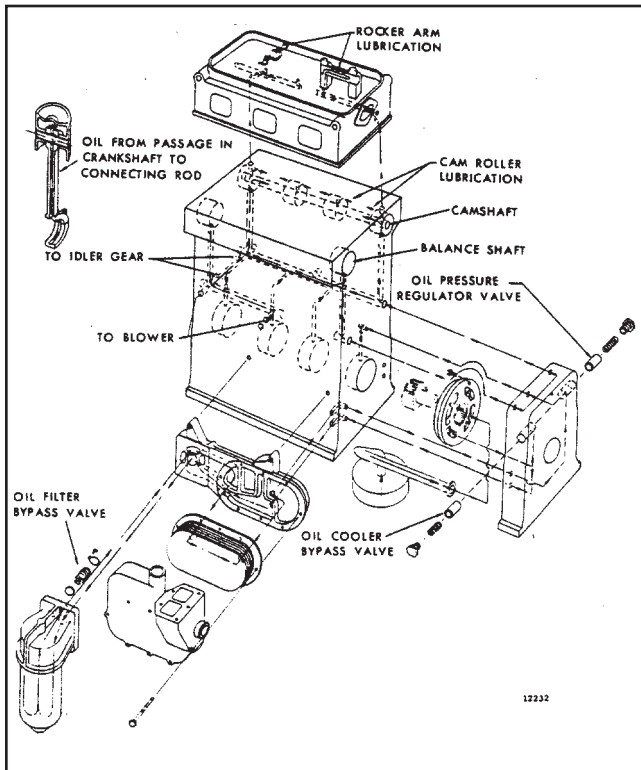

Fig. 1 - I-53 Lubricating System Schematic

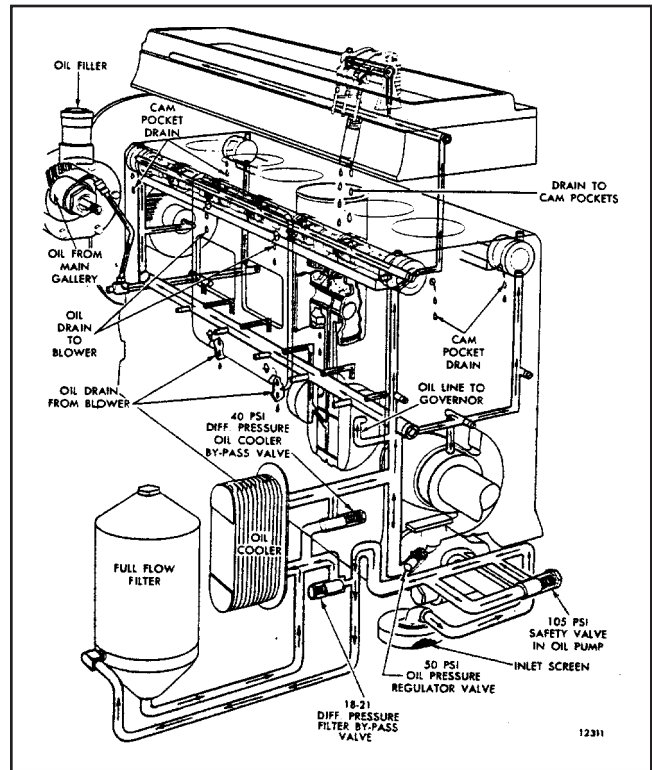

Fig. 2 - I-71 Lubricating System Schematic

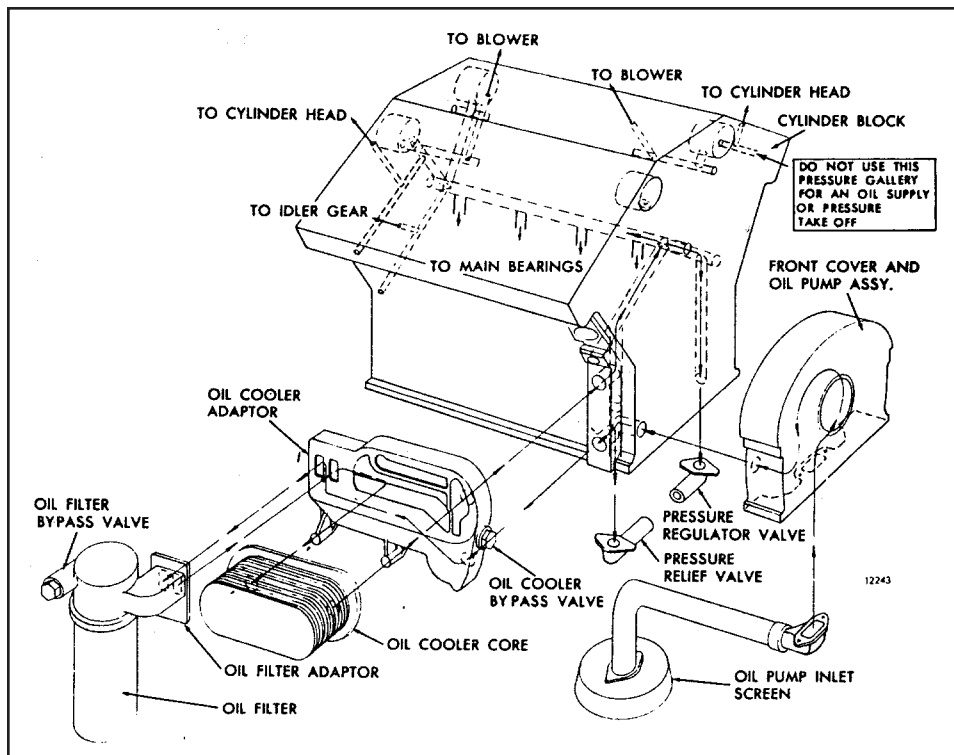

Fig. 3 - V-71 & 92 Lubricating System Schematic

## LUBE OIL FILTER

All engines use full flow oil filters of the "spin on" type element. They have a non-replaceable pleated paper cartridge. Each filter has an integral bypass valve in the event of plugging or for cold start purposes.

**NOTE:** Use only approved filters with the recommended filtration micron rating. See parts list Section 6 for proper service part numbers.

### Replacing Spin on Oil Filter(s)

1. Obtain the Detroit Diesel recommended replacement lube oil filter. See Chart, Page 44.
2. Use a properly sized oil filter wrench, such as Kentmoore P/N J24783, and remove filter(s).
3. Discard used filter(s) as recommended by EPA.
4. Clean the filter base mounting surface with a lint free cloth.
5. Lightly coat the oil filter seal with clean engine oil.
6. Start threading the new replacement filter onto the threaded portion of the base and hand tightened until the seal contacts the filter head. With the filter wrench, continue to tighten two-thirds of a turn.
7. Start engine and check for leaks. If any are found do not put engine into service until corrections are made.

## LUBRICATING OIL REQUIREMENTS

Hundreds of commercial oils are marketed today, but labeling terminology differs among suppliers and can be confusing. Some marketers may claim that their lubricant is suitable for all makes of diesel engines and may list engine makes and types, including Detroit Diesel, on their containers. Such claims, by themselves, are insufficient as a method of lubricant selection for DDFP engines.

The proper lubricating oil for all DDFP engines is selected, based on SAE Viscosity Grade and API (American Petroleum Institute) Service Designation. Both of these properties are displayed in the API Symbol, which is illustrated within the specific requirements. For DDFP engines, the proper lubricant must also possess a sulfated ash content below 1.0% mass.

Lubricating oils for Non-Tactical Military usage currently

specify a Mil-L-2104F type oil. Because they may display different viscosity grades, it is necessary to use a SAE 40 grade only.

## TWO-CYCLE ENGINES

DETROIT DIESEL SERIES 53, 71, 92  
LUBRICANT REQUIREMENTS

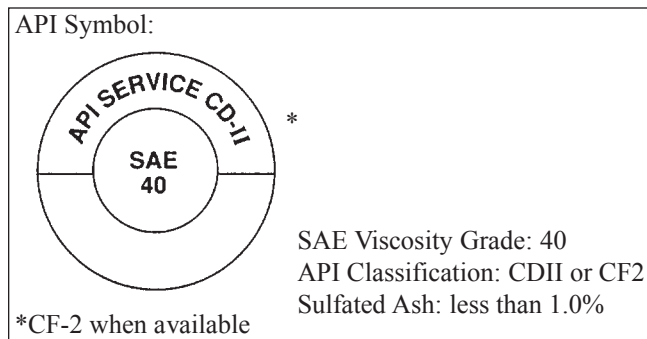

This is the only oil recommended for Detroit Diesel Engines used in DDFP service. Lubricants meeting these criteria have provided maximum engine life when used in conjunction with recommended oil drain and filter maintenance schedules.

Certain engines operating conditions may require exceptions to this recommendation. They are as follows:

1. For continuous high temperature operation (over 100° F 38° C Ambient), the use of SAE 50 grade lubricant in all DDFP engines is recommended.
2. The API Performance Category CF2 represents an enhanced level of lubricant performance over CD-II category which it replaces. Lubricants meeting this new performance level may not be readily available. During this interim period oils labeled as API CD-II may be used.
3. When the use of High Sulfur Diesel Fuel (greater than 0.5% mass) is unavoidable, the use of lubricants with higher Total Base Numbers (alkalinity) are recommended. Refer to Fig. 4 for minimum TBN numbers to be used for normal service.

## MAINTENANCE AND SERVICE PROCEDURE

### Weekly

- 1). Check oil level with the engine stopped. Please refer to "note" listed in Section 3 under oil level dipstick for proper oil level check.



- 2). During and after weekly maintenance run, check over entire engine for signs of oil leaks. Repair immediately if found or call your authorized DDC Distributor/Dealer for service.

**NOTE:** If oil is observed coming from the air box drain tubes while running, review maintenance procedure on page 19.

### Yearly

Stationary diesel engines collect condensation in the engine oil pan while at rest. When in use, lubricating oil undergoes deterioration from combustion by-products and contamination. For these reasons, regardless of the appearance of the oil, change oil and filter(s) annually.

**CAUTION:** Use only recommended lube oil and oil filters. Internal engine damage and/or excessive wear could occur using unauthorized materials.

### LUBRICATING OIL ANALYSIS

Oil Analysis kits are available through the DDC Distributor Network for efficient monitoring of the lubricating oil in a DDFP engine. Refer to Parts Information Section 6 to order.

Oil Analysis consists of a series of laboratory tests conducted on the engines lubricant. Some tests show the condition of the engine and others show the condition of the lubricant. Refer to Fig. 4 for warning limits.

TWO CYCLE ENGINES ONLY			
	ASTM Designation	Condition Measured	53, 71, 92
Pentane Insolubles % Max.	D 893	Engine Combust.	1.0
Carbon (Soot) Content, TGA Mass % Max.	E-1131	Engine Combust.	0.8
Viscosity at 40°C cS	D 445 & D 2161	Engine & Oil	40.0
% Max. Increase			15.0
% Max. Decrease			
Total Base Number (TBN)			
Min.	D 664 or D4739	Oil	1.0
Min.	D 2896		2.0
Water Content (dilution) Vol. % Max.	D 95	Engine	0.30
Flash Point °C Reduction Max.	D 92	Engine Fuel Dil.	20.0
Fuel Dilution Vol. % Max.	*	Engine	2.5
Glycol Dilution PPM Max.	D 2982	Engine	1000
Iron Content PPM Fe Max.	**	Engine Wear	150
Copper Content PPM Cu Max.	**	Engine Wear	25
Sodium Content PPM NA Over Baseline Max.	**	Engine Coolant	50
Boron Content PPM B Over Baseline Max.	**	Engine Coolant	20

\* Various Methods

\*\* Elemental Analyses are conducted using either emission or atomic absorption spectroscopy. Neither method has an ASTM designation.

Fig. 4 - Oil Analysis Warning Limits

**OIL VOLUME**

For specific oil quantities please refer to Technical Data Section 5 for each engine model listing.



Fig. 5 - Typical Oil Fill Location

## COOLING SYSTEM

**The Engine Cooling System Includes:**

Coolant Pump  
 Heat Exchanger with Overflow Pipe  
 Oil Cooler  
 Pressure Cap-Fill Cap  
 Thermostat & Water Bypass  
 Raw Water Inlet and Discharge  
 Zinc Electrode

**OPERATION**

The heat resulting from combustion in the engine cannot be fully converted into kinetic energy. A major portion of that heat is absorbed by the coolant from the cylinder walls and cylinder heads and must be carried away from the engine. It is the function of the Heat Exchanger to transfer waste engine heat to the raw cooling water.

Inside the heat exchanger tank Fig. 1 is a heat exchanger core, somewhat similar to a miniature radiator. Engine coolant circulates around the heat exchanger core while cool raw water, from a tap on the pressure side of the fire pump, is circulated inside the core carrying away the heat. The installing contractor makes the raw water discharge connection at time of system installation.

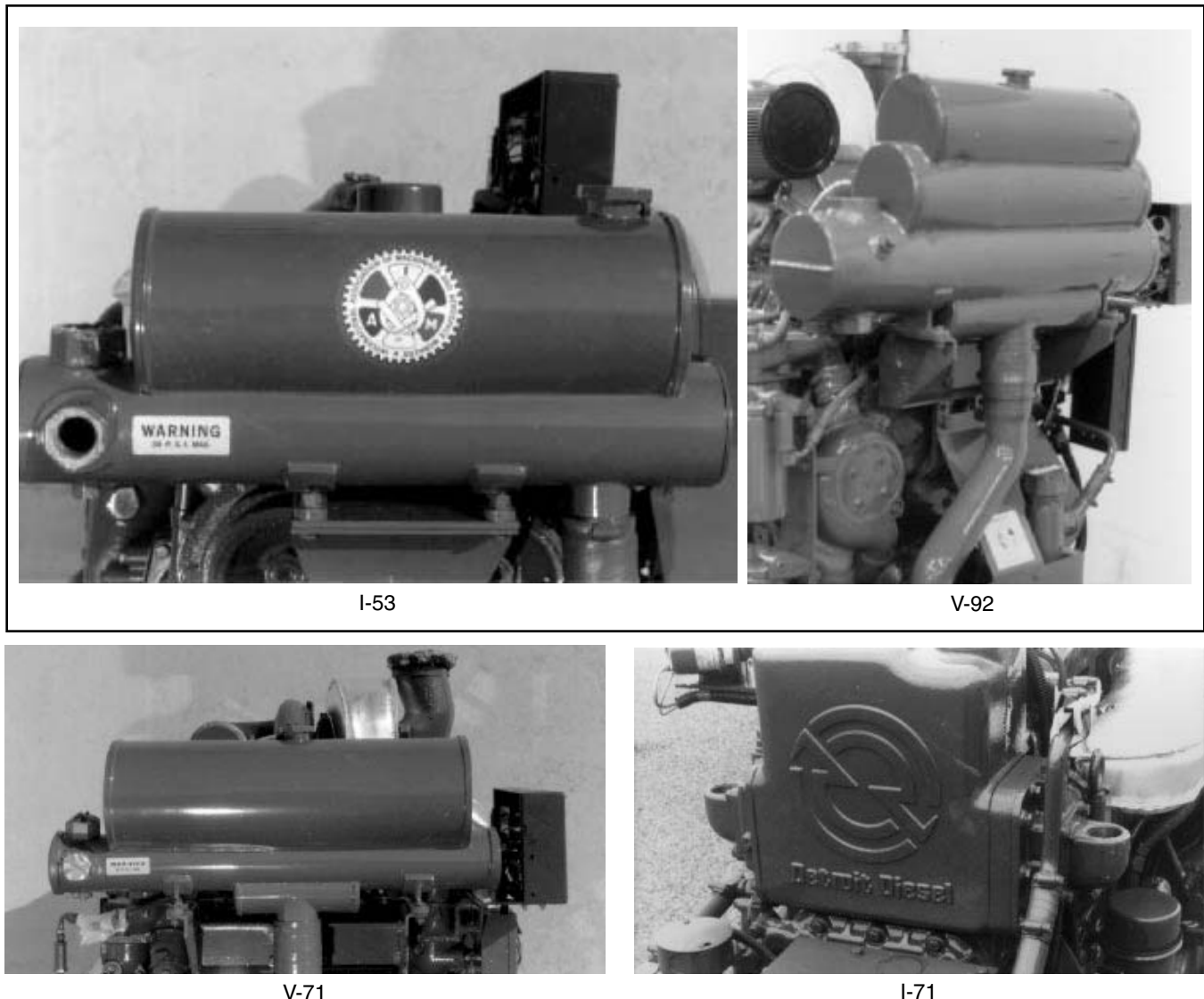

Fig. 1 - Heat Exchanger Cooling System

Engine coolant is circulated by the engine coolant pump. Engine coolant enters the side of the block upon discharge from the oil cooler and coolant pump. Under low pressure, the coolant flows past the cylinders, up through the heads, and then through the open thermostat into the heat exchanger tank. After passing over the heat exchanger core, the coolant then re-enters the coolant pump and starts the cycle over. If the thermostat is closed, coolant would flow down a bypass tube, back to the coolant pump. Under that condition, the coolant bypasses the heat exchanger core and allows the engine to retain some of the heat so it can quickly reach optimum operating temperature.

## ENGINE COOLANT

The following information is provided as a guide for Detroit Diesel engine users in the selection of a suitable coolant.

The water/ethylene glycol/inhibitor coolant mixture used in DDFP engines must meet the following basic requirements:

- Provide for adequate heat transfer.
- Provide protection from cavitation damage.
- Provide a corrosion/erosion resistant environment within the cooling system.
- Prevent formation of scale or sludge deposits in the cooling system.
- Be compatible with engine hose and seal materials.
- Provide adequate freeze and boil over protection.

### WARNING

**A 50% water and 50% anti-freeze solution is required for pump installations. Premixing this solution prior to installing is required. This prevents possible pure anti-freeze chemical reactions to block heater elements which can burn out the element. Please see the technical data Section 5 for proper cooling system capacities of each model.**

## WATER

Water can produce a corrosive environment in the cooling system, and the mineral content may permit scale deposits to form on internal cooling surfaces. Therefore, inhibitors must be added to control corrosion, cavitation, and scale deposits.

Chlorides, sulfates, magnesium and calcium are among the materials which make up dissolved solids that may cause scale deposits, sludge deposits, corrosion or a combination of these. Chlorides and/or sulfates tend to accelerate corrosion, while hardness (percentage of magnesium and calcium salts broadly classified as carbonates) causes deposits of scale. Water within the limits specified in Fig. 2 is satisfac-

tory as an engine coolant when properly inhibited. Use of distilled water is ideal.

	GRAINS PER GALLON	PARTS PER MILLION
Chlorides (Maximum)	40	2.5
Sulfates (Maximum)	100	5.8
Total Dissolved Solids (Maximum)	340	20
Total Hardness (Maximum)	170	10

Fig. 2 Satisfactory Water Limits

## ANTIFREEZE

Use an ethylene glycol coolant (low silicate formulation) that meets or exceeds the standard of either the GM 6038-M formulation (GM 1899-M performance) or ASTM D 4985 requirements.

A 50% coolant/water solution is normally used. Concentrations over 70% are not recommended because of poor heat transfer capability, adverse freeze protection and possible silicate dropout. Concentrations below 30% offer little freeze, boil over or corrosion protection.

## COOLANT INHIBITOR

The importance of a properly inhibited coolant cannot be over-emphasized. A coolant which has insufficient or no inhibitors at all, invites the formation of rust, scale, sludge and mineral deposits. These deposits can greatly reduce the cooling systems efficiency and protection capabilities.

DDC-recommended supplemental coolant inhibitors are a combination of chemical compounds which provide corrosion protection, cavitation suppression, pH controls and prevent scale. These inhibitors are available in various forms, such as liquid packages or integral parts of anti-freeze.

It is imperative that supplemental inhibitors be added to all DDFP engine systems. A pre-charge dosage must be used at the initial fill and the maintenance dosage used at each service interval. Serious damage will occur unless inhibitors are used. Some of the more common corrosion inhibitors are borates, nitrates and silicates.

Inhibitors become depleted through normal operation, additional inhibitors must be added to the coolant as required to maintain original strength levels. Refer to Fig. 3 for proper concentrations of inhibitors.

Do not use soluble oils or chromate inhibitors in DDFP engines. Detrimental effects will occur.

	Min. PPM	Max. PPM
Boron (B)	1000	1500
Nitrite (NO <sup>2</sup> )	800	2400
Nitrates (NO <sup>3</sup> )	1000	2000
Silicon (Si)	50	250
Phosphorous (P)	300	500
pH	8.5	10.5

Fig. 3 - Proper Concentrations Of Inhibitors

To properly check inhibitor concentrations it may be necessary to contact your local DDC Distributor/Dealer for assistance. Refer to Parts Information Section 6, Page 45, to obtain the DDC part number for the Factory Coolant Analysis Kit. This kit can be purchased for nominal fee for analyzing the condition of the engine's coolant.

### PROCEDURE FOR FILLING ENGINE

During filling of the cooling system, air pockets may form. The system must be purged of air prior to being put in service. This is best accomplished by filling with a pre-mix solution, to the top of filler neck. Install the pressure cap, start and run engine until the temperature stabilizes at approximately 170° - 190° F (77° - 91° C). During this warming process, you may



Fig. 4 - Coolant Recovery Bottle

see coolant coming from the overflow tube attached at the pressure cap location. This is a normal condition since the coolant expands as it heats up. When the overflow ceases, stop the engine.

**NOTE:** Air entrapment in I-53 engines is very likely to occur due to cooling system design. Upon initial fill with a pre-mix solution. It is recommended that the coolant be allowed to stand for a four hour period prior to starting.

To verify that the coolant is at a safe operating level, it's best to wait until the engine temperature drops to approximately 120°F (49°C), or lower, before removing the pressure cap. After the cap is removed, the level should be within 2 inches (51mm) of the filler neck.

**NOTE:** I-71 engines have incorporated the use of a coolant recovery bottle (white plastic bottle) Fig 4. During initial filling of the cooling system, it will be necessary to fill the Recovery Bottle to the Cold Full line with the pre-mix solution. Start and run the engine as indicated above. After reaching normal operating temperature check the coolant level in the recovery bottle to verify that the level is at the Hot Full line, if not add coolant to the bottle. Following the same instructions as above, wait for the engine coolant temperature to drop before removing the pressure cap. The coolant level should be at the previously mention height. The coolant level must remain between Hot and Cold run lines on the recovery bottle.

**CAUTION:** Do not remove pressure cap while coolant is at normal operating temperatures. Possible personal injury could result from the expulsion of hot coolant.

### PRESSURE CAP

Like most cooling systems, the Heat Exchanger type operates under pressure. A typical cap shown in Fig. 5 maintains system pressure to raise the coolant boiling point and permits a somewhat higher operating temperature without coolant loss. Pressure cap values can vary in different engine series. Refer to Section 5 for your engine type.

All pressure caps include a vacuum valve which opens during cool down. This prevents an internal vacuum from being formed which could contribute to leaking seals and hoses collapsing.

**NOTE:** I-71 engines use a coolant recovery bottle. The pressure cap includes a rubber ring-type seat. When the cap installed this ring forms a positive seal between the filler neck and cap. During engine cool down, if the wrong type cap is used, coolant cannot transfer back into the heat exchanger from the recovery bottle. This can progress into an overheated engine and possible damage.

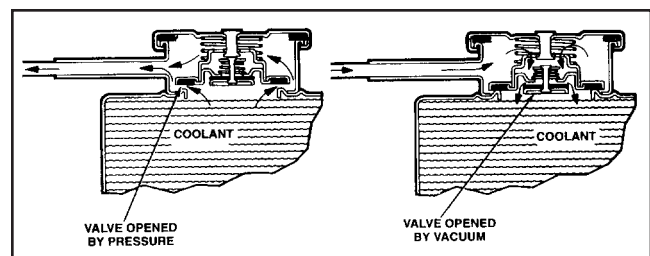

Fig. 5 - Typical Coolant Cap

## COOLANT PUMP

The engine water pump is a centrifugal impeller type pump. It is gear driven on the I-71, V-71 and V-92 Series engines and belt driven on the I-53 Series engines. The rebuildable pump utilizes a shaft and sealed bearing assembly. The V-71 and V-92 incorporate an oil seal and two splash lubricated ball type bearings. Each pump also included a water pump seal weep hole. Should a coolant leak occur at this location, the pump seal must be replaced. Contact your local DDC Distributor/Dealer for assistance. Should a replacement pump be required for repair, use only the exact same type of pump.

## THERMOSTAT

Each pump engine is equipped with a temperature controlling thermostat(s). Normal operating ranges will vary due to engine horsepower and operating speed. The thermostat(s) are located at the front of the cylinder heads. Refer to Section 5 for specific operating temperatures for each engine.

## ENGINE COOLANT HEATER

Fire pump engines must be able to assume full load immediately when used for emergency service. NFPA-20 specifications require an engine coolant heater Figure 6, Page 29, to maintain a minimum temperature of 120° F (49° C). Maintaining this temperature assists the engine to start easily and produce rated horsepower immediately. For fire pump units operation in cold climates optional oil heaters are available to keep the engines lubricating oil at a safe temperature for emergency start purposes. If pump room temperatures drop below 50° F (10° C), oil heaters are required.

On the initial installation of each fire pump engine, it is the responsibility of the installing contractor to wire the heater to the pump room AC circuit. See Section 3 Electrical AC Wiring Diagram, Page 39, for correct wiring to the heater disconnect switch.

**CAUTION:** Do not activate the AC circuit unless the engine cooling system has been filled.

A pre-mix solution must be used. Chemical reactions will occur if pure Ethylene Glycol anti-freeze is allowed to fill the heater cavity with AC circuit is activated.

## HEAT EXCHANGER COOLING

The heat exchanger cooling system is illustrated in Fig. 1, Page 25.

Raw water from the fire pump passes through the heat exchanger core where it lowers the engine coolant temperature 10-15° F (-12° – -9° C). Typical raw water connection points on the heat exchanger are shown in Fig. 7, Page 29.

## HOSES

Specific areas on each DDFP engine use hoses to transfer coolant to and from heat exchangers and immersion heaters. Regular inspections are necessary to verify that no leaks exist. Should replacements be required contact your local DDC Distributor/Dealer for assistance.

**NOTE:** Silicon Hose material for the immersion heaters must meet SAE J20 Requirements with a maximum heat operating range of 350° F (177° C). Do not replace these hoses with any other type material.

**NOTE:** Hose clamps required for silicon type hose, must have a shielded inner band or be of a constant torque type (spring loaded). If the second type is used, do not collapse spring by over tightening.

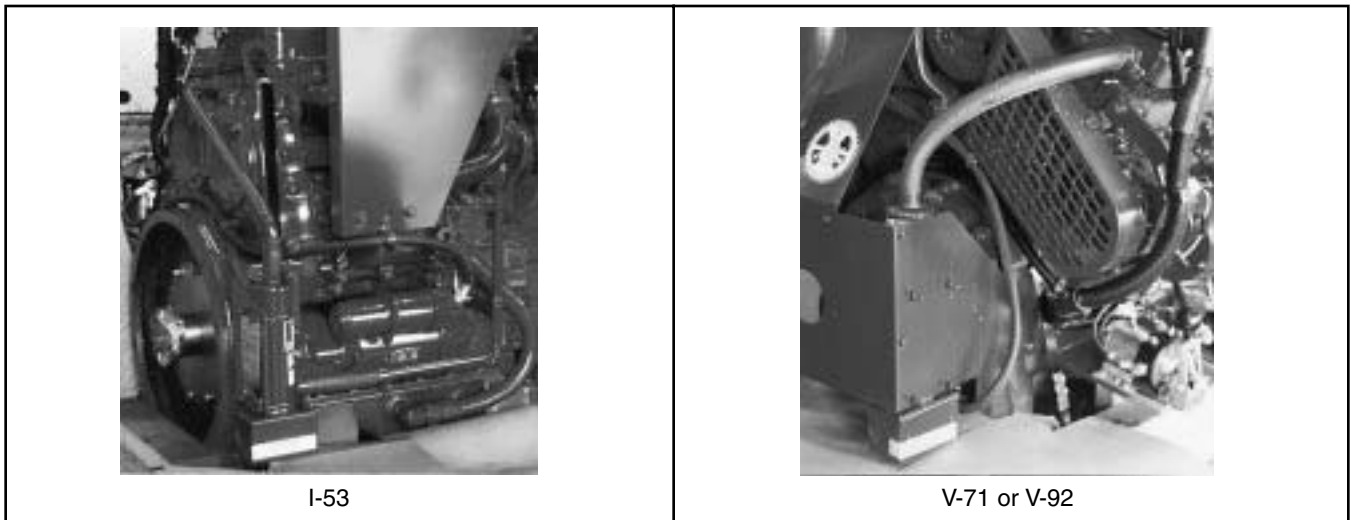

Fig. 6 - Engine Heaters

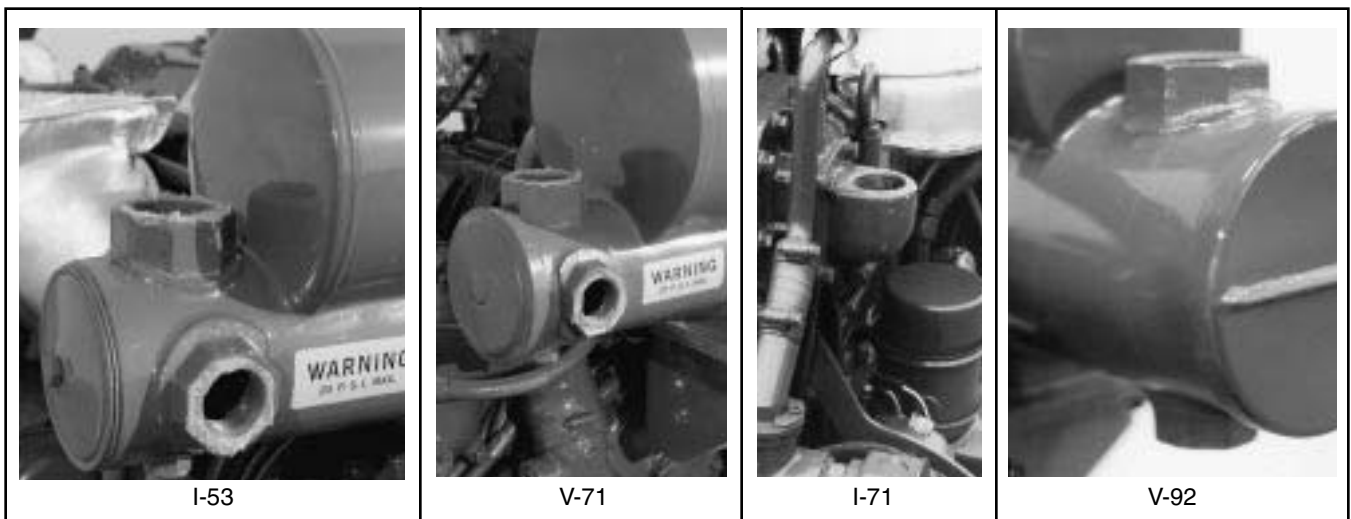

Fig. 7 - Raw Water Connections

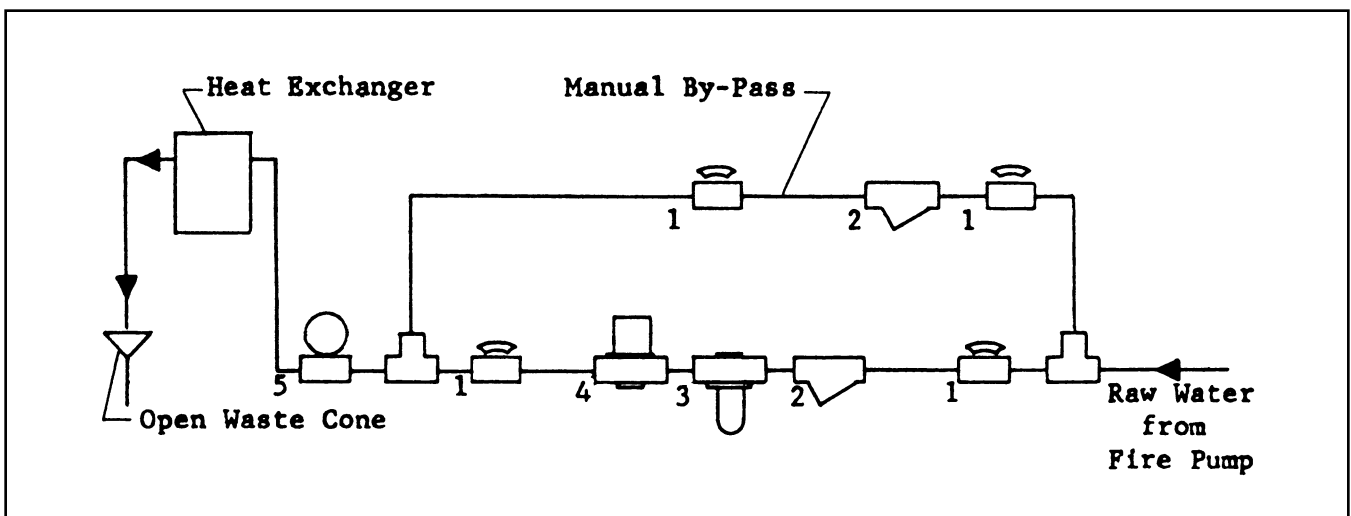

Fig. 8 - Typical Cooling Loop

## RAW WATER SYSTEM (Cooling Loop)

This system is provided by the pump manufacturer or pump assembler as part of the complete engine-pump-controller package. Components for the raw water system are selected to ensure adequate flow through the heat exchanger as required by the engine at specific raw water temperature. The raw water system is generally referred to as the "cooling loop". A typical cooling loop includes the following components as shown in Fig. 8, Page 29;

1. Indicating manual valves
2. Water strainers
3. Pressure regulator
4. Solenoid valve (DC)
5. Pressure gauge

The heat exchanger discharge line should be one pipe size larger than the supply line. Additionally, it is recommended that the discharge line rise a minimum of 3" to maintain raw water across the entire cooling core. Discharge is made to an open waste cone as specified in NFPA-20.

**CAUTION:** Damage to the heat exchanger may result if raw water plumbing (supply or discharge) weight or stress is applied to the heat exchanger.

The solenoid valve may be omitted on vertical turbine pump installations where no static pressure exists in the heat exchanger supply line while the engine is not running. Each engine has a minimum requirement of raw water flow. Correct flow through the heat exchanger is critical for maintaining the proper engine operating temperature.

Engine coolant temperature can be adversely affected by insufficient raw water flow and by excessive ambient temperature of the raw water. See the technical data Section 5 for each engine model's minimum raw water flow requirements at 60° F (16° C) and 95° F (35° C) at specified engine RPM ranges. Do not exceed raw water pressure allowance within the heat exchanger.

**NOTE:** Although engine operating temperature may appear normal, engine cooling may be compromised and possible engine damage will result if raw water flow is reduced.

## ZINC ELECTRODE

A sacrificial zinc anode is included with each heat exchanger. Over a period of time, normal electrochemical action will occur between dissimilar metals within the heat exchanger. The rate of material transfer is dependent on the electrolytic strength of the transfer media (raw water). It is the zinc anode that gives up material in this process and thus preserves the integrity of the heat exchanger.

## MAINTENANCE AND SERVICE PROCEDURES

### Weekly

- 1) Check coolant level weekly. The level should be within two inches of the filler neck. Because this is a closed system, when operating temperature is reached, the pressure relief cap may allow some excess coolant to expell out the overflow tube until a stabilized level is reached. Refer to procedure for filling engine in this section.

Check the condition of the pressure relief cap. The rubber seat should be in sound condition. If it is cracked, split or frayed, do not use. Do not attempt to run engine without a pressure cap. Each cap has a relief rating, which is not to be altered if a replacement cap is required. Refer to Section 5 for specific cap type and rating for each engine.

- 2) Inspect all hoses for leaks, repair or replace as necessary.

### Annually

Check coolant inhibitor concentration, if not within values shown in Fig. 2 re-inhibit as necessary.

Check Zinc Electrode, if more than half is deteriorated electrode should be replaced. Contact your local DDC Distributor/Dealer for replacements.

### Every Two Years

Change all hoses.



## ELECTRICAL SYSTEM

### ENGINE OPERATING SYSTEM

The DDFP engines used for fire pump service include two electrical systems. First is the engine heater system (AC), second is the engine starting system (DC). The starting and control circuits are integral with the DC wiring harness but are separated for explaining operation, maintenance and service procedures. Engines are supplied with either a 12 or 24 V-DC system. Depending upon the specific model (refer to Section 5). This includes a starting motor, battery charging alternator, wiring harness, battery insulator, manual contactors, run-stop solenoid and two battery systems. For identification reasons only, usually 12 V-DC systems have 2 batteries, 24 V-DC systems have 4. Under normal operating conditions, signals for running and shutdown are transmitted from the AEC. With the controller switch on "automatic", a specific drop in the fire main line pressure or other pre-programmed signal will result in a start of the diesel engine. Reference the DC wiring diagram Fig. 13, Page 37 or Fig. 14, Page 38.

**CAUTION:** These engines have been pre-set for a specific operational speed (RPM). When started, the engine will quickly reach this setting. The engines do not have idle speed settings. With the AEC switch on "Test", the engine can be test started from the controller using either battery system A or B. Engine stopping is accomplished by switching the controller selector to the "Off" position. Consult the AEC operating manual for specific operational instructions.

**NOTE:** Prior to turning the AEC to any position other than automatic, please read the paragraph labeled "IMPORTANT" in Section 2, Page 11.

The engine DC starting and control system terminates at the DC junction box. The junction box location varies on different engine models, one is typically shown in Fig. 5. From this point, the engine is electrically connected to the automatic engine controller (AEC). Both automatic operation and test signals are sent to the engine from the AEC. Under emergency conditions, and if the AEC should become defective or disconnected from the engine for any reason, it is possible to start the engine by operating the manual contactors. Specific emergency operating instructions are attached to the instrument panel and explained in detail under MANUAL STARTING of this section. Engine wiring diagrams for AC and DC systems are shown in this section.

### ENGINE HEATERS

NFPA-20 specifications require that the engine coolant be maintained at 120° F (54° C) minimum. Additionally, if the pump room temperature should fall below 50° F (10° C), an engine oil heater is recommended. Both coolant and oil heaters use AC power.

All Clarke DDFP engines include immersion heaters. Typically these heaters are mounted at the front of the engine. Some models have horizontal mounting and others are mounted vertical. See Fig. 6, Page 29. Heater wattage ratings vary with engine size. (Refer to Section 5). These heaters are wired to an AC junction box mounted on the engine.

**CAUTION: SHUT OFF AC VOLTAGE BEFORE  
SERVICING ENGINE HEATER**

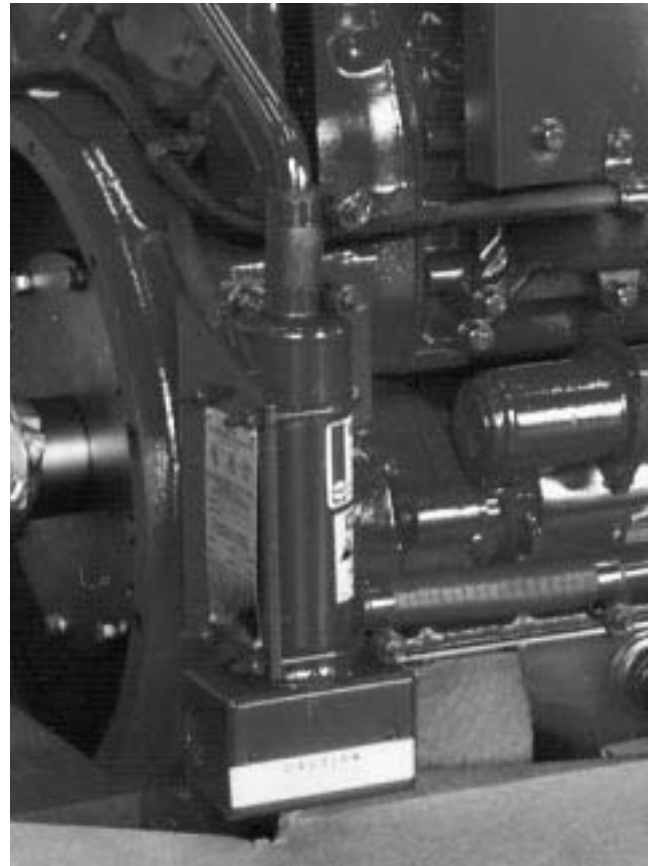

Installation - Jacket Water Heater, Thermostat  
Fig. 1



Fig. 2 - Emergency Operating Instructions



Fig. 3 - Automatic - Manual Mode Selector

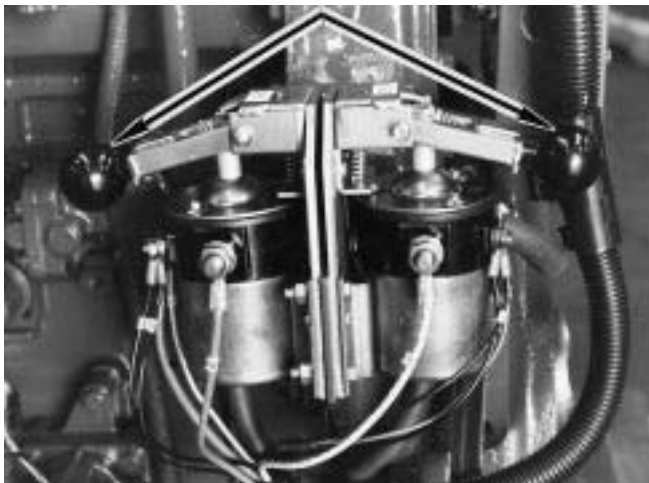

Fig. 4 - Manual Contactors

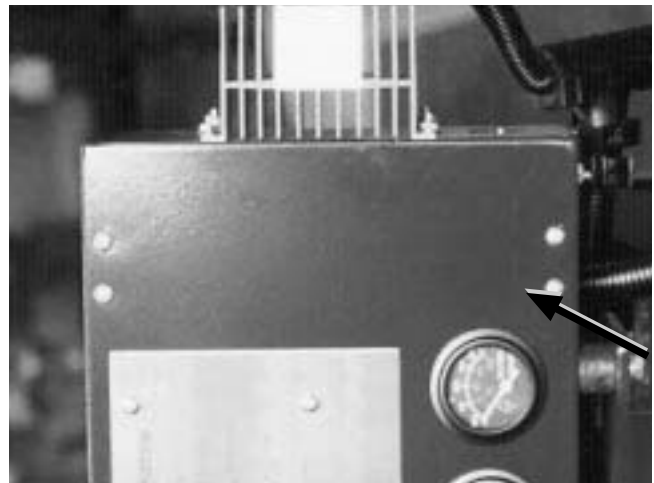

Fig. 5 - DC Junction Box



Fig. 6 - Governor Solenoid



Fig. 7 - Instrument Panel

## MANUAL START INSTRUCTIONS

The engine can be operated without using the engine controller. Use the following procedure when manual starting is required. Refer to Fig. 2, Page 32.

### To Start Engine

1. OPEN COOLING SYSTEM MANUAL BYPASS VALVE. Located on the cooling loop, Fig. 8, Page 29.
2. POSITION **MODE SELECTOR** IN **MANUAL RUN**. Fig. 3, Page 32.
3. POSITION **BATTERY SELECTOR** SWITCH TO BATT. #1.
4. PULL AND HOLD MANUAL CONTACTOR #1, Fig. 4, Page 32 UNTIL ENGINE STARTS, RELEASE AFTER 5 SECONDS. IF UNIT FAILS TO START, POSITION **BATTERY SELECTOR** TO BATT. #2 USE STARTER CONTACTOR #2, AND REPEAT STEP.

### To Stop Engine

1. RETURN **MODE SELECTOR** TO **AUTOMATIC**, AND **MANUAL STOP**, ENGINE WILL STOP.
2. CLOSE COOLING SYSTEM MANUAL BYPASS VALVE.

### IMPORTANT:

**DO NOT LEAVE THE MODE SELECTOR SWITCH IN THE MANUAL RUN POSITION DURING AUTOMATIC OPERATION. (THE CONTROLLER WILL BE UNABLE TO STOP THE ENGINE AND OVERHEAT DAMAGE WILL RESULT)**

**DO NOT POSITION THE BATTERY SELECTOR SWITCH TO A DEFECTIVE BATTERY WHILE IN THE MANUAL MODE.**

## GOVERNOR OPERATING SOLENOID

The DC governor solenoid, Fig. 6, Page 32, is an essential item for the operation of this fire pump system. Upon receiving a signal, the solenoid is energized to move the governor into the run position.

This solenoid remains energized during engine operation. To stop the engine, the solenoid de-energizes and the governor returns to the "no fuel" position by spring action.

## INSTRUMENTATION

Figure 7, Page 32 shows the instrumentation panel which contains the following gauges: tachometer with integral hourmeter (1), engine oil pressure (P.S.I.) (2), battery voltmeter (3), engine coolant temperature (°F) (4), battery isolator (5). Engine overspeed switch is mounted to rear of gauge panel Figure 8.



Fig. 8 - Overspeed Reset

**Tachometer and Integral Hourmeter** - This meter receives its signal from the overspeed switch to allow operator to read engine RPM, in addition the hour meter records a cumulative total of engine operating hours.

**Oil Pressure** - This mechanical gauge gives engine oil pressure readings in english and metric units (PSI & kPA). Connection location to the engine will vary per engine model.

**Engine Coolant Temperature** - This temperature gauge indicates the engines coolant outlet temperature in degrees fahrenheit (°F) and centigrade (°C).

**Voltmeter** - This gauge identifies the voltage level of the battery according to the position of the battery selector switch.

### SPEED SWITCH

After the engine has started and reached 1000 RPM, the speed switch signals the controller to terminate the starter cranking action. An overrunning clutch is included on the starter drive to prevent damage from overspeeding when the unit starts.

**NOTE:** When starting unit with manual contactors, release contactor handle as soon as engine starts.

In the event of an engine overspeed the speed switch signals the AEC and effects an engine shutdown. A MANUAL RESET button is included on the switch and must be "pushed in" to reset the speed switch after unit has shutdown from an

overspeed condition. The reset button is shown in Fig. 8, Page 33.

**NOTE:** Engine will not restart after an overspeed shutdown, UNTIL OPERATOR RESETS THIS BUTTON. DO NOT ATTEMPT TO RESTART ENGINE UNTIL VERIFICATION HAS BEEN MADE AS TO THE REASON FOR OVERSPEED.

A magnetic-pickup, mounted in the flywheel housing provides the input signal for the overspeed switch. See Fig. 9, pickup mounting. The magnetic-pickup senses the speed of the engine by counting the flywheel ring gear teeth per second. There should be a 0.03" (.762 MM) air gap between the top of the ring gear and the magnetic pickup. With a gear tooth aligned with the center of the magnetic pickup hole, thread the pickup in until it touches the gear tooth and then back it out  $1/2$  turn. Tighten jam nut while holding the pickup in position. Reconnect to wiring harness.

**WARNING:** All current production DDFP engines use electronic overspeed protection controls. Due to the delicate nature of this device, it is mandatory that diagnostic probing of the circuitry be done with the electrical power off. Probing with any device that causes amperage to exceed ratings will damage this control. This warning applies to terminals of the overspeed switch and inside the junction box. This type of failure is not warrantable.



Fig. 9 - Magnetic Pickup

## BATTERY CHARGING ALTERNATOR

This belt driven engine alternator provides power to recharge both battery banks directly through the battery isolator. The battery isolator prevents backfeed from one battery bank to the other. The alternator is mounted at the front of the engine as shown in Fig. 10. The alternator is belt driven from the crankshaft or camshaft pulley.

## STARTER

The DC electric starting motor provides cranking effort to initiate an engine start. Located on the flywheel housing of the engine, it is shown in Fig. 11, Page 35.

For automatic operation or test operation, the signal for start initiation comes from the controller. For manual start at the engine, activating either contactor #1 or #2 should start the engine. Review the MANUAL OPERATING INSTRUCTIONS for additional details on Page 33.



Fig. 10 - Typical Alternator



Fig. 11 - Typical Starter

Two alarm switches provide condition signal to the engine controller. First, a coolant temperature switch is provided and mounts on front of right cylinder head. When the coolant temperature reaches 205° F (96° C), the switch closes and causes a light to burn and sounds an alarm bell on the engine controller. Second, an oil pressure switch is provided for low oil pressure signal. Should oil pressure drop to or below 20 P.S.I. (138 kPA) the NC switches closes and causes a light to burn and sounds an alarm bell on the engineer controller.

Neither a high coolant temperature or a low oil pressure signal will cause the controller to stop the engine. The alarm bell can be silenced at the controller and an investigation made to determine cause of the signal. The controller lights will continue to burn until the fault is corrected.

## BATTERIES

NFPA-20 requires that fire pump systems include two independent battery units. Each battery bank must have capacity, at 40° F (4.5° C), sufficient to maintain cranking speed

through a 6 minute cycle (15 seconds cranking and 15 seconds rest, in 12 consecutive cycles). Battery recommendations are shown for each engine on the respective model in Section 5.

## BATTERY CABLES

Customer Supplied Battery Cables should be sized as recommended in Section 5.

## WIRING DIAGRAMS (DC)

Wiring diagrams represented in this section, Figs. 13 and 14 have two basic differences. Other than optional voltage differences of 12V or 24V, the primary difference is the engine instrumentation. Certain DDFP models use mechanical type others use electric instruments.

Should it be necessary to diagnose a wiring problem, see below for identifying which diagram to use.

Fig. 13 Drawing #CO7264 includes Amp Meter with Mechanical instruments.

Fig. 14 Drawing #CO7484 includes Volt Meter with Electrical instruments.

Verify which type your engine has before proceeding.

## WIRING DIAGRAMS (AC)

The diagram represented in Fig. 15 identifies the AC wiring requirements necessary for the jacket water heater. An optional lube oil heater is included.

These heaters have optional voltages, depending on installation requirements. Each heater is controlled by a thermostat mounted in the engine heater.

## MAINTENANCE AND SERVICE PROCEDURES

### ENGINE HEATER

The engine heaters are required by NFPA-20 specification and should maintain the engine coolant at 120° F (54° C). Check the engine temperature gauge for corresponding performance. See Page 39 for AC wiring, diagram.

- A. Condition: - Unit holds minimum 120° F.  
Service: - No Service Required
- B. Condition: - Unit holds less than 120 F, but above room temperature.  
Service: - One heater element may not be functioning.

Check wiring or replace defective element.

- C. Condition: - Engine coolant at room temperature  
Service: - 1. Check 120V-AC POWER SOURCE.  
2. Check wiring connections.  
3. Check thermostat function, see Fig. 1.  
4. Replace element if defective.

**CAUTION:** DISCONNECT AC POWER TO HEATER SYSTEM BEFORE DRAINING ENGINE COOLANT.

**MANUAL CONTACTORS**

Operate contactors to assure manual operation. If over-center contact is not functional or if other inoperative condition exist, replace the UNIT. Check bolts for tightness, wires for tightness or damage. (Fig. 12).

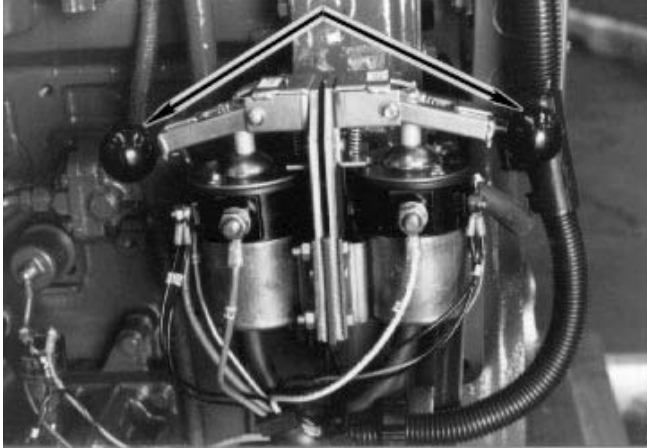

Fig. 12 - Manual Contactors

**MAXIMUM** torque for the battery cable studs is 5-10 ft.-lbs. DO NOT EXCEED this limitation.

**CAUTION** Contactors are connected to live batteries. Display appropriate caution with tools.

**INSTRUMENTS**

Check instruments while running unit to be sure they are functional. Replace broken or defective instruments. If hour-meter is replaced, record accumulated hours from replaced hourmeter.

**SPEED SWITCH**

This is an electronic unit. If damaged or defective, the entire switch must be replaced.

**BATTERY CHARGING ALTERNATOR**

Inspect the terminals for corrosion and loose connections and the wiring for broken wires. Replace or repair as necessary. Service alternator with authorized Delco service dealer.

**WARNING:** DO NOT RUN THE I-53 SERIES WITHOUT THE ALTERNATOR INSTALLED. (Drive belts also drive the coolant pump).

New standard V-belts will stretch after the first few hours of operation. Run the engine for 15 minutes to seat the belts, then readjust the tension. Check the belts and tighten after 1/2 hour and again after 6 months. Thereafter, check the tension of the drive belts every 6 months and adjust if necessary. Adjust the belt tension so that a firm push with the thumb, at a point midway between the two pulleys, will depress the belt 1/2" to 3/4".

**STARTER**

Same service and maintenance as recommended for battery charging alternator. Service starter with an authorized Delco service dealer.

**BATTERIES**

Check the specific gravity of the electrolyte in each cell of the battery each week. In warm weather, however, it should be checked more frequently due to a more rapid loss of water from the electrolyte. The electrolyte level should be maintained in accordance with the battery manufacturer's recommendations. Keep all terminals clean and free from corrosion.

**NOTE:** Coating terminal connection with petroleum jelly will prevent rapid corrosion buildup.

**WIRING SYSTEM**

Annually, open the DC junction box and check tightness of all terminal connections. Additionally, reference DC wiring diagram, Fig. 13, 14, Page 37 & 38 and check tightness of

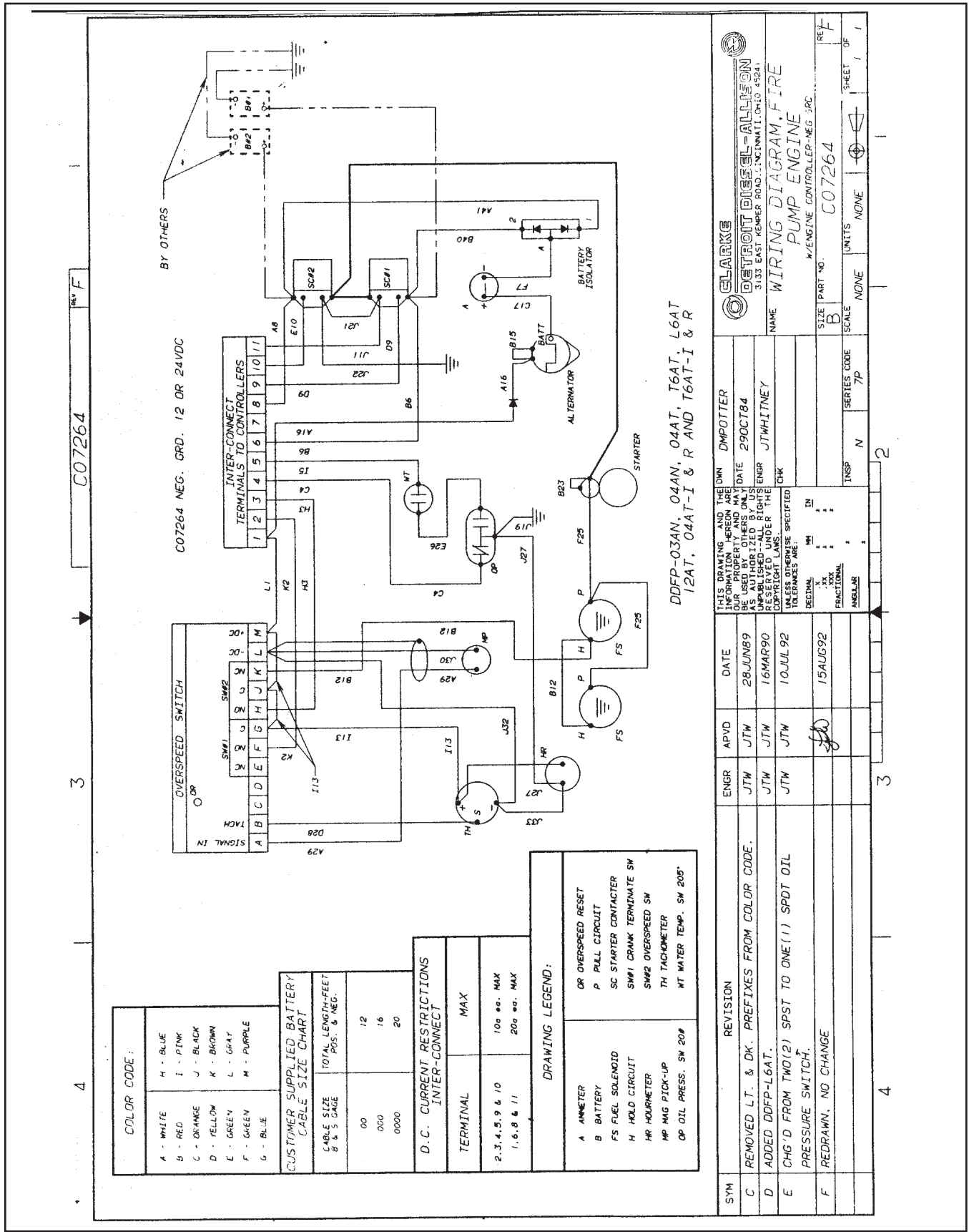

Fig. 13 - DC Wiring Diagram  
Engines With Mechanical Guages

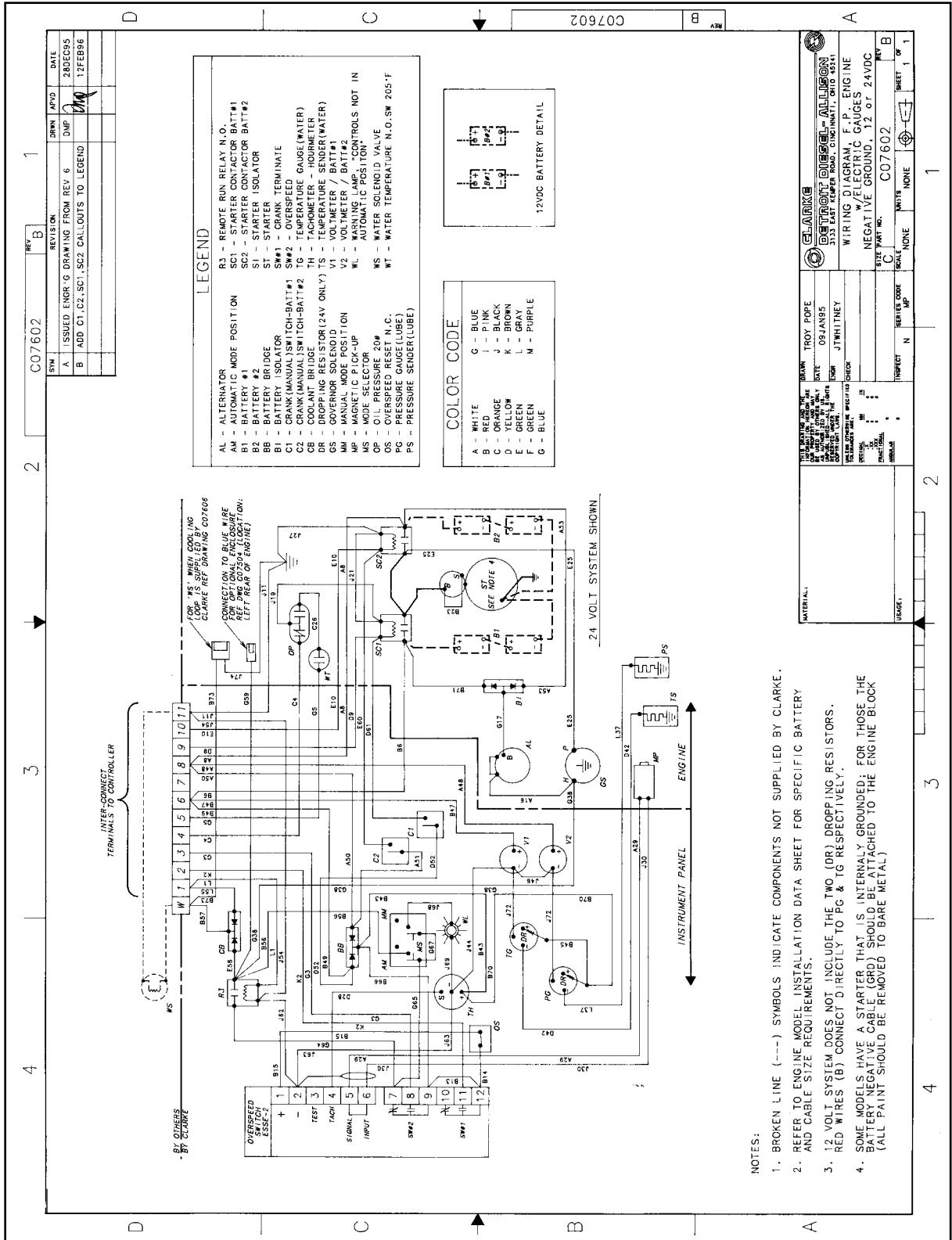
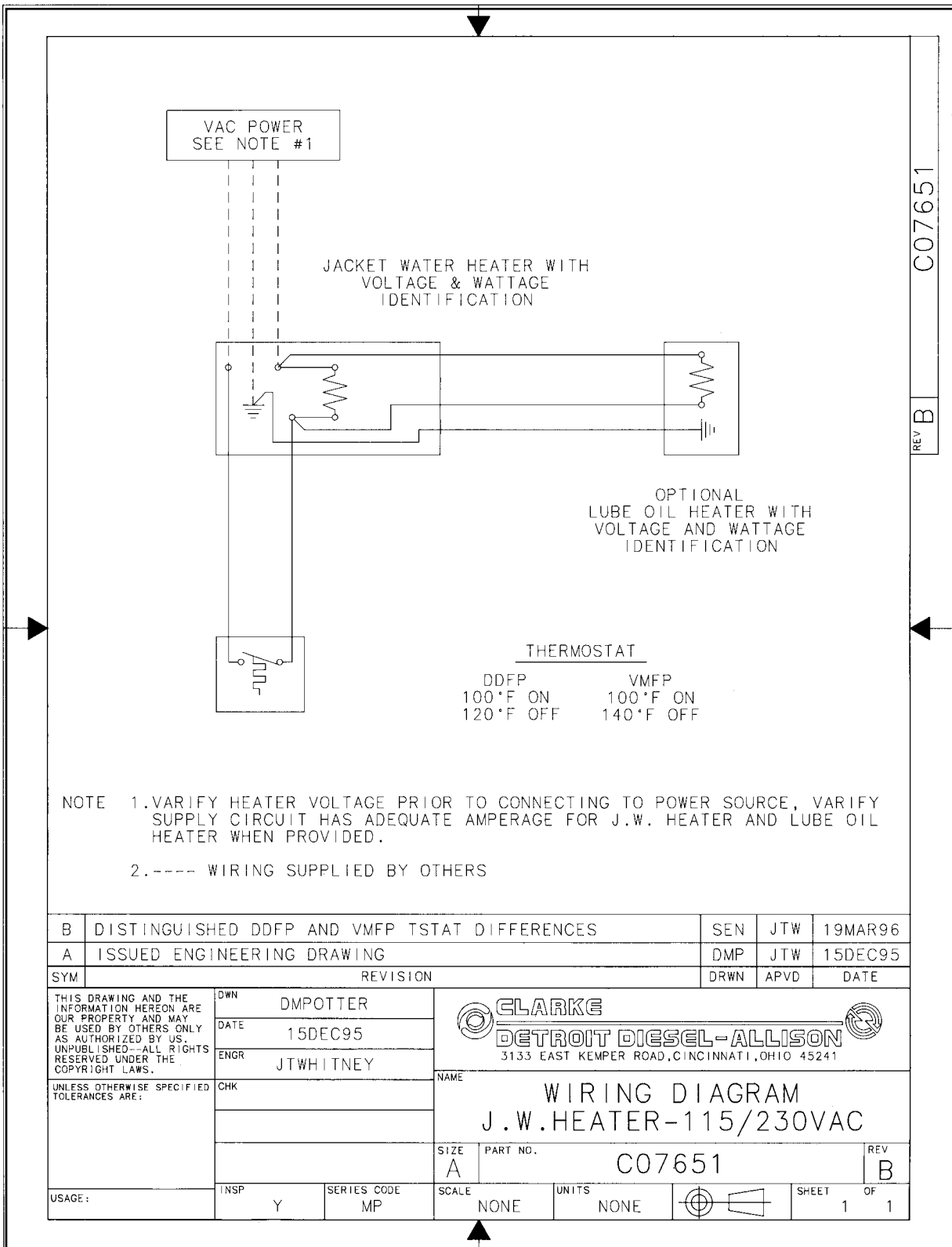

Fig. 14 - DC Wiring Diagram Engines With Electrical Gauges





C07651  
REV B

Fig. 15 - AC Wiring Diagram

## FALK DRIVE HUB

DDFP engines are offered with a standard FALK drive hub, (engine half only). See Page 41 for FALK coupling installation instructions.

If your engine includes this type coupling, please refer to the following for service and maintenance information.

Other pump drive options available are vertical turbine drive shaft adaptor or a standard engine flywheel. Neither of these require regular maintenance, they are however, very critical components and should receive weekly inspections during the regular maintenance run.

**FALK**  
a good name in industry™

Steelflex® Couplings • Installation and Maintenance

Type T10 • Sizes 1020 –1140 & 20–140

(Page 1 of 6)

### How To Use This Manual

This manual provides detailed instructions on maintenance, lubrication, installation, and parts identification. Use the table of contents below to locate required information.

### Table of Contents

Introduction.....	Page 1
Lube Fittings.....	Page 1
Limited End Float.....	Page 1
Lubrication.....	Pages 1-2
Installation & Alignment Instructions.....	Pages 2-4
Annual Maintenance, Relube & Disassembly.....	Page 4
Installation & Alignment Data.....	Page 5
Parts Identification & Parts Interchangeability.....	Page 6

**CAREFULLY FOLLOW THE INSTRUCTIONS IN THIS MANUAL FOR OPTIMUM PERFORMANCE AND TROUBLE FREE SERVICE.**

### INTRODUCTION

This manual applies to Sizes 1020T thru 1140T and 20T thru 140T10 Falk Steelflex Tapered Grid Couplings. Unless otherwise stated, information for Sizes 1020T thru 1140T applies to Sizes 20T thru 140T respectively, e.g. 1020T = 20T, 1100T = 100T, etc. These couplings are designed to operate in either the horizontal or vertical position without modification. Beginning in 1994, these couplings are being supplied with one set of inch series fasteners and one set of metric fasteners. Use either set of fasteners, depending on your preference. Refer to Page 6 for part interchangeability.

The performance and life of the couplings depend largely upon how you install and service them. Carefully follow the instructions in this manual for optimum performance and trouble free service.

**CAUTION:** Consult applicable local and national safety codes for proper guarding of rotating members. Observe all safety rules when installing or servicing couplings.

**WARNING:** Lockout starting switch of prime mover and remove all external loads from drive before installing or servicing couplings.

### LUBE FITTINGS

Cover halves have 1/8 NPT lube holes. Use a standard grease gun and lube fitting as instructed on Page 4.

### LIMITED END FLOAT

When electric motors, generators, engines, compressors and other machines are fitted with sleeve or straight roller bearings, limited axial end float kits are recommended for protecting the bearings. Falk Steelflex couplings are easily modified to limit end float; refer to Manual 428-820 for instructions.

### TYPE T10 STEELFLEX COUPLING

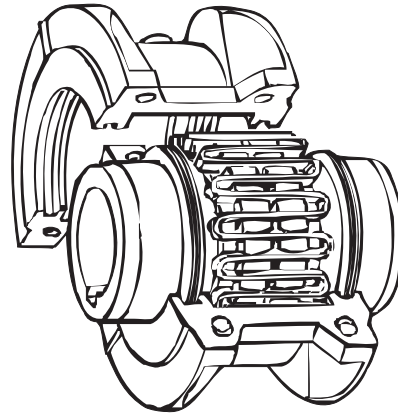

### LUBRICATION

Adequate lubrication is essential for satisfactory operation. Page 2 provides a list of typical lubricants and specifications for general purpose and long term greases. Because of its superior lubricating characteristics and low centrifuge properties, Falk Long Term Grease (LTG) is highly recommended. Sizes 1020T to 1090T10 are furnished with a pre-measured amount of grease for each coupling. The grease can be ordered for larger size couplings.

The use of general purpose grease requires re-lubrication of the coupling at least annually.

### Long Term Grease (LTG)

The high centrifugal forces encountered in couplings separate the base oil and thickener of general purpose greases. Heavy thickener, which has no lubrication qualities, accumulates in the grid-groove area of Steelflex couplings resulting in premature hub or grid failure unless periodic lubrication cycles are maintained.

Falk Long Term Grease (LTG) was developed specifically for couplings. It resists separation of the oil and thickener and is an extreme pressure grease.

Steelflex couplings initially lubricated with LTG will not require re-lubrication until the connected equipment is stopped for servicing. If a coupling leaks grease, is exposed to extreme temperatures, excessive moisture, or experiences frequent reversals, more frequent lubrication may be required.

Although LTG grease is compatible with most other coupling greases, the mixing of greases may dilute the benefits of LTG.

### USDA Approval

LTG has the United States Department of Agriculture Food Safety & Inspection Service approval for applications where there is no possibility of contact with edible products. (H-2 ratings).

**CAUTION:** Do not use LTG in bearings.



## Installation and Maintenance • Steelflex® Couplings

(Page 2 of 6)

Type T10 • Sizes 1020 –1140 &amp; 20–140

### Specifications — Falk LTG

The values shown are typical and slight variations are permissible.

**AMBIENT TEMPERATURE RANGE** — -20°F (-29°C) to 250°F (121°C).

**MINIMUM BASE OIL VISCOSITY** — 3300SSU (715cST) @ 100°F (38°C)

**THICKENER** — less than 12% by weight.

**CENTRIFUGE SEPARATION CHARACTERISTICS** — ASTM #D4425 (Centrifuge Test) — K36 = 2/24 max., very high resistance to centrifuging.

**NLGI GRADE** (ASTM D-217) — 1/2

**MINIMUM DROPPING POINT** — with 60 stroke worked penetration value in the range of 320 to 365 — 350°F (177°C) min.

**MINIMUM TIMKEN O.K. LOAD** — 40 lbs.

**ADDITIVES** — Rust and oxidation inhibitors that do not corrode steel or swell or deteriorate synthetic seals.

### Packaging

**14 OZ. CARTRIDGES** — For use in standard grease guns. Sufficient quantity to initially lubricate sizes thru 1090T.

**35 LB. PAIL** — Ideal for larger size couplings or many smaller sizes.

**120 LB. KEG & 400 LB. DRUM** — For plants with central storage areas. A pump with a pressurized follower plate is required for dispensing grease.

**CASE LOTS OF 24-14 OZ. CARTRIDGES** — also available.

### General Purpose Grease

**Annual Lubrication** — The following specifications and lubricants for general purpose grease apply to Falk Steelflex couplings that are lubricated annually and operate within ambient temperatures of 0°F to 150°F (-18°C to 66°C). For temperatures beyond this range (see Table 1), consult the Factory.

If a coupling leaks grease, is exposed to extreme temperatures, excessive moisture or experiences frequent reversals, more frequent lubrication may be required.

### Specifications — General Purpose Coupling Lubricants

The values shown are typical and slight variations are permissible.

**DROPPING POINT** — 300°F (149°C) or higher.

**CONSISTENCY** — NLGI No. 2 with 60 stroke worked penetration value in the range of 250 to 300.

**SEPARATION AND RESISTANCE** — Low oil separation rate and high resistance to separation from centrifuging.

**LIQUID CONSTITUENT** — Possess good lubricating properties ... equivalent to a high quality, well refined petroleum oil.

**INACTIVE** — Must not corrode steel or cause swelling or deterioration of synthetic seals.

**CLEAN** — Free from foreign inclusions.

### General Purpose Greases Meeting Falk Specifications

Lubricants listed below are typical products only and should not be construed as exclusive recommendations.

**TABLE 1 — General Purpose Greases**

Ambient Temperature Range	0°F to 150°F (-18°C to +66°C)	-30°F to 100°F (-34°C to +38°C) <sup>1</sup>
NLGI Grade	#2	#2
Manufacturer	Lubricant <sup>2</sup>	Lubricant <sup>2</sup>
Amoco Oil Co.	Amolith Grease #2	Amolith Grease #2
Atlantic Richfield Co.	Litholene HEP 2	Litholene HEP 2
Chevron U.S.A. Inc.	Chevron Dura-Lith EP-2	Chevron Dura-Lith EP 2
Cities Service Co.	Citigo HEP-2	Citigo HEP 2
Conoco Inc.	EP Conolith #2	EP Conolith #2
Exxon Company, USA	Ronex MP	Ronex MP
Gulf Oil Corp.	Gulfcrown Grease #2	Gulfcrown Grease #2
E. F. Houghton & Co.	Cosmolube #2	Cosmolube #1
Imperial Oil Ltd.	Esso MP Grease H	Lotemp EP
Kendall Refining Co.	Kenlube L-421 Grease	Kenlube L-427 Grease
Keystone Div. (Pennwalt)	#81 Light	#84 Light
Mobil Oil Corp.	Mobilux EP 111	Mobilux #1
Phillips Petroleum Co.	IB & RB Grease	Philube IB & RB Grease
Shell Oil Co.	Alvania Grease #2	Alvania Grease #2
Standard Oil Co. (OH)	Factran #2	Factran #2
Sun Oil Company	Prestige 42	Prestige 42
Texaco Lubricants	Starplex HD2	Multifak EP2
Texaco Canada Inc.	Marfak HD 2	Marfak AP
Union Oil Co. (CA)	Union Unoba #2	Union Unoba #2
Valvoline Oil Co.	Val-Lith EP #2	Val-Lith EP #2

<sup>1</sup> For northern climate applications. For continuous operation at constant ambient temperatures less than 0°F (-18°C) — for example, refrigeration systems; consult The Falk Corporation.

<sup>2</sup> Lubricants listed may not be suitable for use in the food processing industry; check with lube manufacturer for approved lubricants.

### INSTALLATION OF TYPE T10 STEELFLEX TAPERED GRID COUPLINGS

#### Installation

Only standard mechanics tools, wrenches, a straight edge and feeler gauges are required to install Falk Steelflex couplings.

Coupling Sizes 1020T thru 1090T are generally furnished for CLEARANCE FIT with setscrew over the keyway. Sizes 1100T and larger are furnished for an INTERFERENCE FIT without a setscrew.

**CLEARANCE FIT HUBS** — Clean all parts using a non-flammable solvent. Check hubs, shafts and keyways for burrs. Do not heat clearance fit hubs. Install keys, mount hubs with flange face flush with shaft ends or as otherwise specified and tighten setscrews.

**INTERFERENCE FIT HUBS** — Furnished without setscrews. Heat hubs to a maximum of 275°F (135°C) using an oven, torch, induction heater or an oil bath.

When an oxy-acetylene or blow torch is used, use an excess acetylene mixture. Mark hubs near the center of their length in several places on hub body with a temperature sensitive crayon, 275°F (135°C) melt temperature. Direct flame towards hub bore using constant motion to avoid overheating an area.

**FALK**  
a good name in industry®

## Steelflex® Couplings • Installation and Maintenance

Type T10 • Sizes 1020 –1140 & 20–140 (Page 3 of 6)

**WARNING:** If an oil bath is used, the oil must have a flash point of 350°F (177°C) or higher. Do not rest hubs on the bottom of the container. Do not use an open flame in a combustible atmosphere or near combustible materials.

Heat hubs as instructed above. Mount hubs as quickly as possible with hub flange face flush with shaft end. Allow hubs to cool before proceeding. Insert setscrews (if required) and tighten.

### Maximize Performance And Life

The performance and life of couplings depend largely upon how you install and maintain them. Before installing couplings, make certain that foundations of equipment to be connected meet manufacturers' requirements. Check for soft foot. The use of stainless steel shims is recommended. Measuring misalignment and positioning equipment within alignment tolerances is simplified with an alignment computer. These calculations can also be done graphically or mathematically.

Alignment is shown using spacer bar and straight edge. This practice has proven to be adequate for many industrial applications. However, for superior final alignment, the use of dial indicators (see Manual 458-834 for instructions), lasers, alignment computers or graphical analysis is recommended.

### 1 — Mount Seals And Hubs

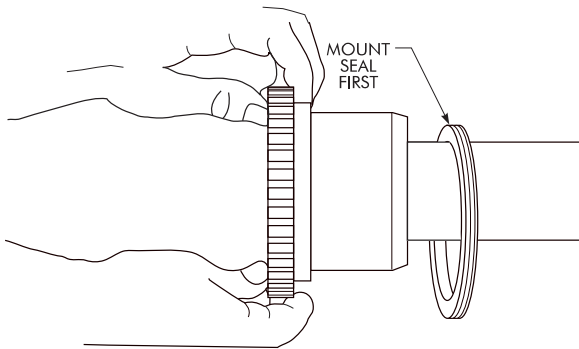

Lock out starting switch of prime mover. Clean all metal parts using a non-flammable solvent. Lightly coat seals with grease and place on shafts BEFORE mounting hubs. Heat interference fit hubs as previously instructed. Seal keyways to prevent leakage. Mount hubs on their respective shafts so the hub face is flush with the end of its shaft unless otherwise indicated. Tighten setscrews when furnished.

### 2 — Gap and Angular Alignment

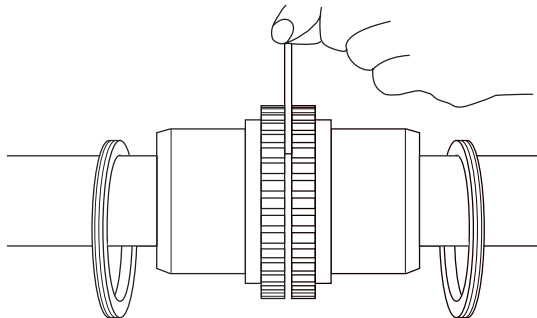

Use a spacer bar equal in thickness to the gap specified in Table 2, Page 5. Insert bar as shown below left, to same depth at 90° intervals and measure clearance between bar and hub face with feelers. The difference in minimum and maximum measurements must not exceed the ANGULAR installation limits specified in Table 2.

### 3 — Offset Alignment

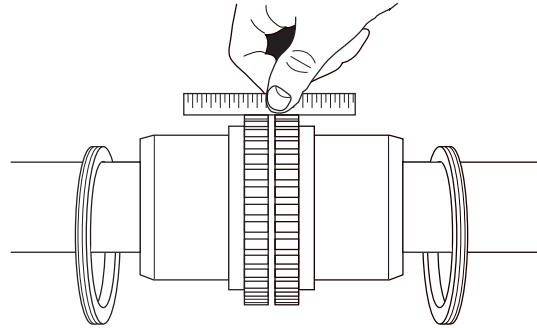

Align so that a straight edge rests squarely (or within the limits specified in Table 2) on both hubs as shown above and also at 90° intervals. Check with feelers. The clearance must not exceed the PARALLEL OFFSET installation limits specified in Table 2. Tighten all foundation bolts and repeat Steps 2 and 3. Realign coupling if necessary.

### 4 — Insert Grid

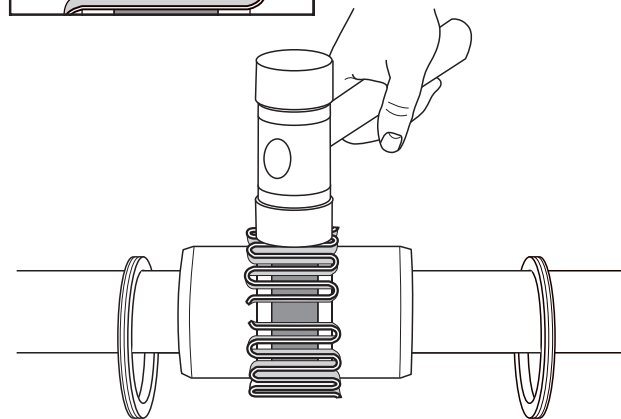
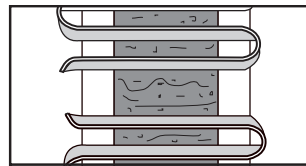

Pack gap and grooves with specified lubricant before inserting grid. When grids are furnished in two or more segments, install them so that all cut ends extend in the same direction (as detailed in the exploded view picture above); this will assure correct grid contact with non-rotating pin in cover halves. Spread the grid slightly to pass over the coupling teeth and seat with a soft mallet.

## Installation and Maintenance • Steelflex® Couplings

(Page 4 of 6)

Type T10 • Sizes 1020 –1140 &amp; 20–140

**FALK**  
 a good name in industry®

## 5 — Pack With Grease And Assemble Covers

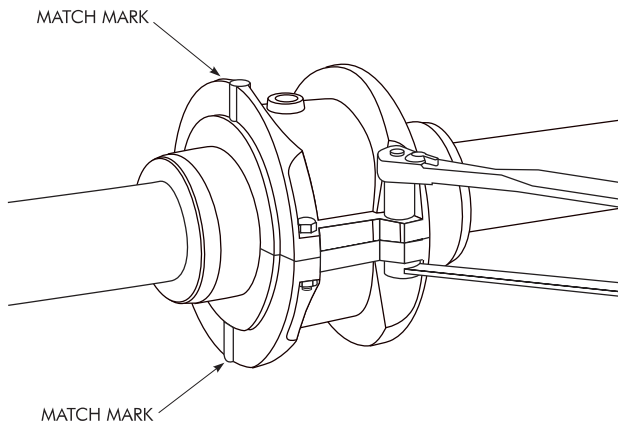
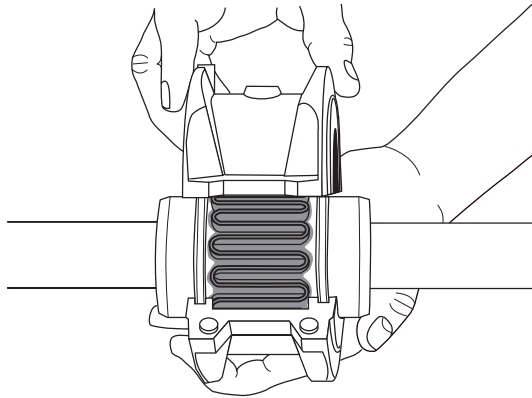

Pack the spaces between and around the grid with as much lubricant as possible and wipe off excess flush with top of grid. Position seals on hubs to line up with grooves in cover. Position gaskets on flange of lower cover half and assemble covers so that the match marks are on the same side (see above). If shafts are not level (horizontal) or coupling is to be used vertically, assemble cover halves with the lug and match mark

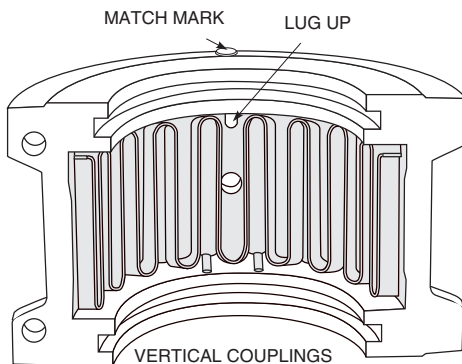

UP or on the high side. Push gaskets in until they stop against the seals and secure cover halves with fasteners, tighten to torque specified in Table 2. Make sure gaskets stay in position during tightening of fasteners. **CAUTION:** Make certain lube plugs are installed before operating.

## ANNUAL MAINTENANCE

For extreme or unusual operating conditions, check coupling more frequently.

1. Check alignment per steps on Page 3. If the maximum operating misalignment limits are exceeded, realign the coupling to the recommended installation limits. See Table 2 for installation and operating alignment limits.
2. Check tightening torques of all fasteners.
3. Inspect seal ring and gasket to determine if replacement is required. If leaking grease, replace.
4. When connected equipment is serviced, disassemble the coupling and inspect for wear. Replace worn parts. Clean grease from coupling and repack with new grease. Install coupling using new gasket as instructed in this manual.

## Periodic Lubrication

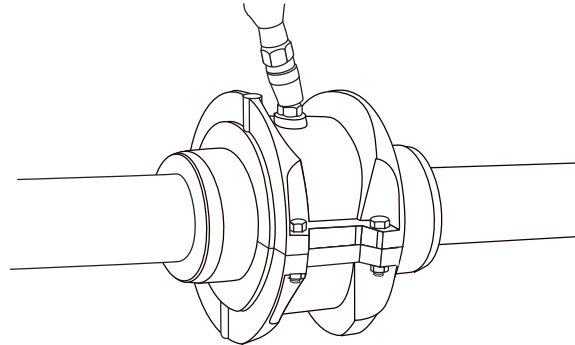

The required frequency of lubrication is directly related to the type of lubricant chosen, and the operating conditions. Steelflex couplings lubricated with common industrial lubricants, such as those shown in Table 1, should be relubed annually. The use of Falk Long Term Grease (LTG) will allow relube intervals to be extended to beyond five years. When relubing, remove both lube plugs and insert lube fitting. Fill with recommended lubricant until an excess appears at the opposite hole. **CAUTION:** Make certain all plugs have been inserted after lubricating.

## Coupling Disassembly And Grid Removal

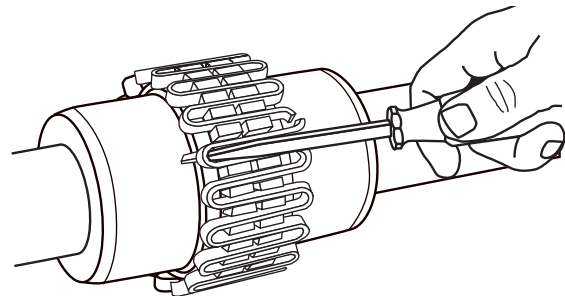

Whenever it is necessary to disconnect the coupling, remove the cover halves and grid. A round rod or screwdriver that will conveniently fit into the open loop ends of the grid is required. Begin at the open end of the grid section and insert the rod or screwdriver into the loop ends. Use the teeth adjacent to each loop as a fulcrum and pry the grid out radially in even, gradual stages, proceeding alternately from side to side.



Steelflex® Couplings • Installation and Maintenance  
Type T10 • Sizes 1020 –1140 & 20–140 (Page 5 of 6)

**TYPE T COUPLING INSTALLATION & ALIGNMENT DATA**

Maximum life and minimum maintenance for the coupling and connected machinery will result if couplings are accurately aligned. Coupling life expectancy between initial alignment and maximum operating limits is a function of load, speed and lubrication. Maximum operating values listed in Table 2 are based on cataloged allowable rpm.

Values listed are based upon the use of the gaps listed, standard coupling components, standard assemblies and cataloged allowable speeds.

Values may be combined for an installation or operating condition. Example: 1060T max. operating misalignment is .016" parallel plus .018" angular.

NOTE: For applications requiring greater misalignment, refer application details to the Factory.

Angular misalignment is dimension X minus Y as illustrated below.

Parallel misalignment is distance P between the hub center lines as illustrated below.

End float (with zero angular and parallel misalignment) is the axial movement of the hubs(s) within the cover(s) measured from "O" gap.

ANGULAR MISALIGNMENT

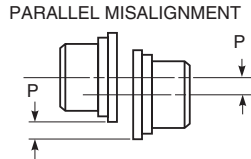
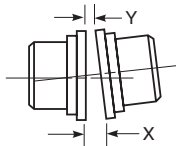

END FLOAT

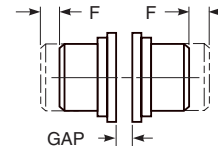

Size	Installation Limits						Operating Limits						Cover Fastener Tightening Torque Values		Allow Speed (rpm)	Lube Wt.	
	Parallel Offset-P		Angular (x-y)		Hub Gap ± 10%		Parallel Offset-P		Angular (x-y)		End Float Physical Limit (Min.) 2 x F		In. Series Fasteners (lb.-in.)	Metric Fasteners (Nm)		lb.	kg
	Max. In.	Max. mm	Max. In.	Max. mm	In.	mm	Max. In.	Max. mm	Max. In.	Max. mm	In.	mm					
1020T	.006	.15	.003	.08	.125	3	.012	.30	.010	.25	.210	5.33	100	11.3	4500	.06	.03
1030T	.006	.15	.003	.08	.125	3	.012	.30	.012	.30	.198	5.03	100	11.3	4500	.09	.04
1040T	.006	.15	.003	.08	.125	3	.012	.30	.013	.33	.211	5.36	100	11.3	4500	.12	.05
1050T	.008	.20	.004	.10	.125	3	.016	.41	.016	.41	.212	5.38	200	23.6	4500	.15	.07
1060T	.008	.20	.005	.13	.125	3	.016	.41	.018	.46	.258	6.55	200	23.6	4350	.19	.09
1070T	.008	.20	.005	.13	.125	3	.016	.41	.020	.51	.259	6.58	200	23.6	4125	.25	.11
1080T	.008	.20	.006	.15	.125	3	.016	.41	.024	.61	.288	7.32	200	23.6	3600	.38	.17
1090T	.008	.20	.007	.18	.125	3	.016	.41	.028	.71	.286	7.26	200	23.6	3600	.56	.25
1100T	.010	.25	.008	.20	.188	5	.020	.51	.033	.84	.429	10.90	312	35	2440	.94	.43
1110T	.010	.25	.009	.23	.188	5	.020	.51	.036	.91	.429	10.90	312	35	2250	1.1	.51
1120T	.011	.28	.010	.25	.250	6	.022	.56	.040	1.02	.556	14.12	650	73	2025	1.6	.74
1130T	.011	.28	.012	.30	.250	6	.022	.56	.047	1.19	.551	14.00	650	73	1800	2.0	.91
1140T	.011	.28	.013	.33	.250	6	.022	.56	.053	1.35	.571	14.50	650	73	1650	2.5	1.14

TABLE 3 — Coupling Cover Fastener Identification

SIZE	INCH SERIES FASTENERS				METRIC FASTENERS	
	Old Style		New Style			
1020-1070T10		SAE Grade 8		SAE Grade 8		Property Class 10.9
1080-1090T10		SAE Grade 8		SAE Grade 8		Property Class 10.9
1100-1140T10		SAE Grade 5		SAE Grade 5		Property Class 8.8

<sup>1</sup> Older style covers, Sizes 1020T10 thru 1070T10 must utilize socket head cap screws and locknuts held by the cover.

Installation and Maintenance • Steelflex® Couplings



(Page 6 of 6) Type T10 • Sizes 1020 –1140 & 20–140

**PARTS IDENTIFICATION**

All coupling parts have identifying part numbers as shown below. Parts 3 and 4 (Hubs and Grids), are the same for both Type T10 and T20 couplings. All other coupling parts are unique to Type T10. When ordering parts, always SPECIFY SIZE and TYPE shown on the COVER.

**PARTS INTERCHANGEABILITY**

Parts are interchangeable between Sizes 20T and 1020T, 30T and 1030T, etc. except as noted.

GRIDS — Size 1020T thru 1140T Steelflex couplings use blue grids. Older models, 20T thru 140T, use orange grids.

**CAUTION:** Blue grids may be used in all applications, but DO NOT substitute orange grids for blue.

COVERS — **CAUTION:** DO NOT mix cover halves of different designs. Sizes 1020T thru 1070T10 covers have been manufactured in several different two-rib designs and 80T thru 140T covers have been manufactured with two and three ribs.

HARDWARE ó Older style covers, Sizes 1020T10 thru 1070T10, utilized socket head cap screws with captured locknuts. The new style covers use hex head cap screws (either inch or metric) and unrestrained locknuts. Specify either inch series SOCKET head or inch or metric series HEX head cap screws when ordering replacement parts.

**PART NUMBER LOCATION**

**PART NUMBERS**

1. Seal (T10)
2. Cover (T10)
3. Hub (Specify bore and keyway)
4. Grid
5. Gasket (T10)
6. Fasteners (T10) ó Coupling may be supplied with one set each of inch series fasteners and metric fasteners.
7. Lube Plug

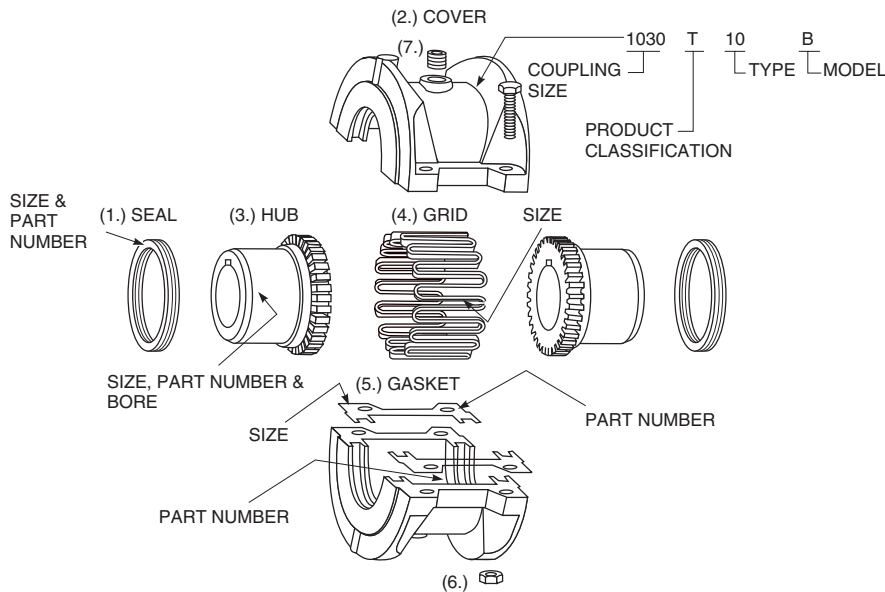

**ORDER INFORMATION**

1. Identify part(s) required by name above.
2. Furnish the following information.  
 EXAMPLE:  
 Coupling Size: 1030  
 Coupling Type: T10  
 Model: B  
 Bore: 1.375  
 Keyway: .375 x .187
3. Price parts from Price List 422-110 and appropriate discount sheet.

## ENGINE TUNE-UP

There is no scheduled interval for performing an engine tune-up. As long as the engine is performing satisfactorily, no tune-up should be necessary.

### SPEED CONTROL

The engine speed is pre-set at the factory to correspond to the full load pump installation requirement. In accordance with

NFPA-20 requirements, this is a tamper-proof mechanism.

**NOTE:** This engine has no idle speed setting.

If engine performance is not satisfactory, contact your local D.D.C. Distributor/Dealer.

If required, an engine repair manual may be obtained from the authorized D.D.C. Distributor/Dealer in your area.

## MECHANICAL GOVERNOR - SPEED ADJUSTMENT

A mechanical governor controls the engine speed. The governor is a flyweight force versus spring force device that will control the rate of fuel delivery to the engine so as to balance the two forces. The solenoid on the governor is only used to set the governor to the RUN or STOP position. Speed adjustment is possible by adjusting the spring force via a tamper proof mechanism.

All governors are adjusted to the FM/UL/ULC nameplate BHP and **full load** pump speed before leaving Clark & D.D.A. During Start-Up Inspection or when placing reconditioned units into service, some minor speed adjustments may be required. It is recommended that this adjustment be performed by the authorized Detroit Diesel Distributor or Dealer representative.

The governor is located as follows:

- I-53 Series** at the upper left rear of engine
- I-71 Series** at the upper right front of engine
- V Series** at the front of blower in the vee of the block.

See page 43 for the identification of the engine series for a specific model.

Figure 1 shows a typical I-53 Series engine governor. In this picture, the cover has been removed to expose the mechanism for adjusting engine speed. By loosening the jam nut next to the governor body, the adjusting nut can then be rotated clockwise to increase engine speed and counter-

clockwise to reduce engine speed.

Figure 2 provides the speed adjustment instructions for 71 and 92 Series engines.

**ATTENTION:** D.D.C. Distributor/Dealer Mechanic. The 53 Series Governor High Speed Spring Gap is .006" (.15mm) to be set @ zero RPM! This governor does not have idle capability or a buffer screw.

**NOTE:** Be sure to resecure the jam nut after making speed adjustments. Replace the cover when ad-



Figure 1 - Speed Adjustment I-53 Series



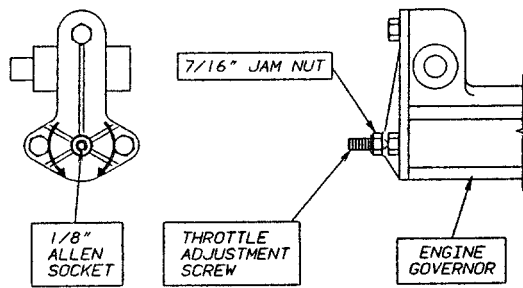

1. WHILE HOLDING THROTTLE ADJUSTING SCREW WITH ALLEN WRENCH: LOOSEN JAM NUT.
2. WHILE HOLDING JAM NUT: TURN THROTTLE ADJUSTING SCREW WITH ALLEN WRENCH.
  - TURN CLOCKWISE TO INCREASE RPM.
  - TURN COUNTER-CLOCKWISE TO DECREASE RPM.
3. WHILE HOLDING THROTTLE ADJUSTING SCREW: TIGHTEN JAM NUT.

Figure 2 - Speed Adjustment 71 & 92 Series

### GOVERNOR SOLENOID-ADJUSTMENT

The mechanical governor is controlled by a DC solenoid. A spring loaded yield link is included as part of the external linkage from the run/stop lever to governor solenoid.

**IMPORTANT:** To insure the engine will produce rated nameplate horsepower, the gap between the yield link and the solenoid plunger must be properly adjusted. (Refer to Figure 3.)

### YIELD LINK GAP CHECK

Position the mode selector switch on the instrument panel (Fig. 3, Page 32), to the MANUAL position. Manually push the solenoid plunger into the solenoid. When the plunger is at full travel, the hold coil magnetic field will hold the plunger, linkage and the run/stop lever in the run position. Push on the plunger spring bolt, not the linkage or the lever. Check the gap at the narrowest point and adjust if necessary. (Refer to Fig. 3). After the check is completed return the mode selector switch to the AUTOMATIC position.

**WARNING:** DO NOT leave the MODE SELECT OR switch in the MANUAL RUN position during AUTOMATIC operation. (The controller will be unable to stop the engine and OVERHEATED DAMAGE WILL RESULT)

### 53 SERIES ENGINES

Adjust the Gap by loosening the Lever Clamping Bolt (Fig. 3), and rotating the Run/Stop Lever on the governor shaft to the desired position and re-torque the clamping bolt. Re-check the gap and repeat adjustments if necessary. After the check is completed return the mode selector switch to the AUTOMATIC position.

After the gap has been properly adjusted, and with the governor solenoid de-energized, in the ST OP position, adjust the Plunger Stop Bolt. Set at zero clearance with the Plunger Spring Bolt, then turn one full turn clockwise and lock with the Jam Nut.

**WARNING:** DO NOT leave the MODE SELECT OR switch in the MANUAL RUN position during AUTOMATIC operation. (The controller will be unable to stop the engine and OVERHEATED DAMAGE WILL RESULT)

When the adjustments have been completed, start the engine from the ENGINE CONTROLLER (AEC), using the MANUAL mode. Verify the Gap Dimension again, then stop the engine. Return all controls to the AUTOMATIC mode.

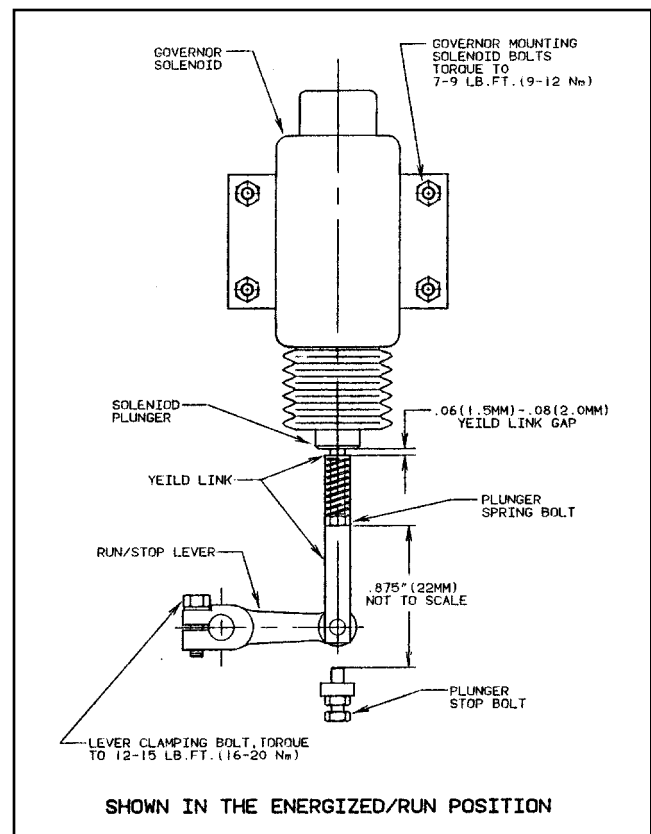

Figure 3 - Shown in the Energized/Run Position

**V-71 AND V-92 SERIES ENGINES**

Adjust the gap by loosening the four (4) Governor Solenoid Mounting Bolts (Fig. 3), slide the Solenoid to the desired position and re-torque the mounting bolts. Re-check the gap and repeat the adjustment if necessary. After the check is completed return the mode selector switch to the AUTOMATIC position.

**WARNING:** DO NOT leave the MODE SELECTOR switch in the MANUAL RUN position during AUTOMATIC operation. (The controller will be unable to stop the engine and OVERHEATED DAMAGE WILL RESULT)

When the adjustments have been completed, start the engine from the ENGINE CONTROLLER (AEC), using the MANUAL mode. Verify the Gap Dimension again, then stop the engine. Return all controls to the AUTOMATIC mode.

**INLINE 71 SERIES (Ref. Fig. 4, Pg. 42-B)**

STEP 1. With the mounting bracket, torsion spring (under levers), upper and lower levers in place, adjust the upper lever as follows:

- Insert a  $\frac{1}{4}$ " bolt approximately  $2\frac{1}{2}$ " long through hole in upper lever so it extends down through locating hole in the mounting bracket.
- Remove rocker cover and manually hold the injector control tube in the *NO* fuel position.
- Push both levers down on shaft until they bottom, then raise them  $\frac{1}{8}$ " to provide free movement of the lower lever.
- After verifying all conditions of steps A, B and C, torque the clamping bolt in the upper lever to 7-9 lb. ft.

STEP 2. Adjust rod length so there is a definite tightness when the manual operating handle passes through the straight outward position near the end of its CCW travel. (Tightness equals zero clearance shortened by two turns of one rod end).

STEP 3. Position the solenoids so the centerline of the slide pin equally divides the arc created by the movement of the lever pin. See diagram (Fig. 4).

STEP 4. Adjust equalizer bar as follows:

- Check to be sure the jam nuts on each solenoid shaft are loose.
- Rotate manual operating handle CCW to the locked position for manual operation.
- Remove small screws from rear covers of both solenoids and remove covers.
- Manually, push on one of the solenoid shafts until the contacts at the rear of that solenoid open at least  $\frac{1}{32}$ " (0.79 mm). While holding the solenoid shaft in this position, tighten the jam nuts against the equalizer bar on the plunger at a position that provides a 0.020" (0.51 mm) clearance at gap "A".
- Manually, hold both solenoid shafts as described in 4D above and tighten the two remaining jam nuts against the equalizer bar without causing it to be forced in either direction. The 0.020" (0.51 mm) clearance should be maintained at gap "A".

STEP 5. Operate mechanism both electrically and manually to verify smooth and trouble free operation. During electrical check, verify that rear contacts on both solenoids open at least  $\frac{1}{32}$ ". (0.79 MM) Readjust equalizer bar as required.

STEP 6. Reinstall covers on solenoids.

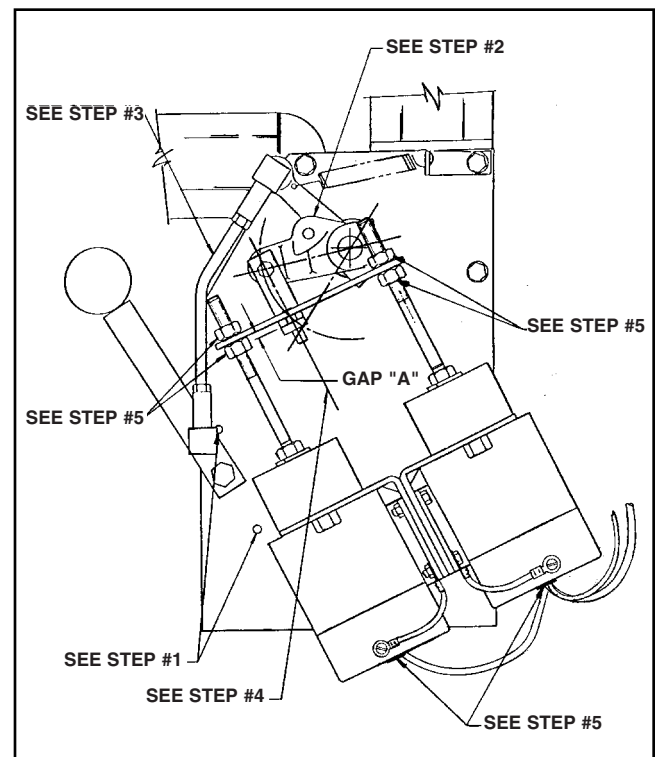

Fig. 4 - Engine Run-Stop Governor Control

## TECHNICAL DATA

This section includes the Installation and Operating Data for all DDFP engine models. Additionally, the basic Engine Materials and Construction are also provided. The specific model and page reference are listed below.

Engine Model	Installation & Operation Data Page	Engine Mat'l & Construction Page
DDFP-03DN	43 - A - 1 & 2	43 - Z - 1
DDFP-03DT	43 - B - 1 & 2	43 - Z - 1
DDFP-L3DT	43 - C - 1 & 2	43 - Z - 1
DDFP-T3DT	43 - D - 1 & 2	43 - Z - 1
DDFP-L6FA	43 - E - 1 & 2	43 - Z - 2
DDFP-T6FA	43 - F - 1 & 2	43 - Z - 2
DDFP-06FA	43 - G - 1 & 2	43 - Z - 2
DDFP-06FH	43 - H - 1 & 2	43 - Z - 2
DDFP-L8FA	43 - I - 1 & 2	43 - Z - 2
DDFP-08FA	43 - J - 1 & 2	43 - Z - 2
DDFP-08FH	43 - K - 1 & 2	43 - Z - 2
DDFP-12FT	43 - L - 1 & 2	43 - Z - 3
DDFP-12FH	43 - M - 1 & 2	43 - Z - 3

---

	Page
<b>Engine Control Wiring Diagram - DC .....</b>	<b>37, 38</b>
<b>Engine Heater Wiring Diagram - AC .....</b>	<b>39</b>

# DDFP-03DN INSTALLATION & OPERATION DATA

## Basic Engine Description

## All Speeds

Engine Manufacturer.....	Detroit Diesel Corp.						
Ignition Type.....	Compression (Diesel)						
Number of Cylinders.....	3						
Bore and Stroke - in. (mm).....	3.875 x 4.5 (98 x 114)						
Displacement - in. <sup>3</sup> (L).....	159 (2.6)						
Compression Ratio.....	21:1						
Combustion System.....	Direct Injection						
Engine Type.....	Inline, 2 Cycle						
Aspiration.....	Natural						
Firing Order (CW Rotation).....	1-3-2						
Charge Air Cooling Type.....	None						
Blower Type.....	Roots						
Blower Drive Ratio.....	2.49:1						
Rotation (Viewed from Front)							
Clockwise.....	Standard						
Counter-Clockwise.....	Consult Factory						
Engine Crankcase Vent System.....	Open						
Dimensions and Weight							
Length - in. (mm) (From Drive Flange).....	35.2 (894.3)						
Width - in. (mm).....	29.6 (751.8)						
Height - in. (mm) (Above Crankshaft Center Line).....	31.3 (795.0)						
Weight, Dry - lb. (kg).....	1128 (512)						
Wet - lb. (kg).....	1205 (547)						
Installation Drawing.....	D-436						

## Cooling System

**1470      1760      2100      2350      2600      2800      3000**

Engine H <sub>2</sub> O Heat - Btu/sec. (kJ/sec.).....	27 (28)	33 (35)	45 (47)	52 (55)	56 (59)	58 (61)	61 (64)
Engine Radiated Heat - Btu/sec. (kJ/sec.).....	11.8 (12.4)						
Heat Exchanger Minimum Flow							
60°F Raw H <sub>2</sub> O - gal./min. (L/min.).....	4.5 (17)	5.0 (19)	6 (23)	6.5 (25)	7.0 (26)	7.5 (28)	8.0 (30)
95°F Raw H <sub>2</sub> O - gal./min. (L/min.).....	6.5 (25)	7.0 (26)	8 (30)	8.5 (32)	9.0 (34)	9.5 (36)	10 (38)
Heat Exchanger Maximum Cooling H <sub>2</sub> O							
Inlet Pressure - lb./in. <sup>2</sup> (kPa).....	20 (138)						
Flow - gal./min. (L/min.).....	40 (151)						
Thermostat, Start to Open - °F (°C).....	170 (77)						
Fully Open - °F (°C).....	187 (86)						
Engine Coolant Capacity - qt. (L).....	16 (14)						
Coolant Pressure Cap - lb./in. <sup>2</sup> (kPa).....	9 (62)						
Maximum Engine H <sub>2</sub> O Temperature - °F (°C).....	200 (93)						
Minimum Engine H <sub>2</sub> O Temperature - °F (°C).....	160 (71)						

## Electric System - DC

## All Speeds

System Voltage (Nominal).....	12
Battery Capacity for Ambients Above 32°F - CCA @ 0°F.....	640
Voltage (Nominal).....	12
Qty. per Battery Bank.....	1
SAE size per J537.....	4D-640
Battery Cable Circuit*, Max Resistance - ohm.....	0.00098
Battery Cable Minimum Size	
0-120 in. Circuit* Length.....	No. 00
121-160 in. Circuit* Length.....	No. 000
161-200 in. Circuit* Length.....	No. 0000
Charging Alternator Output - Amp.....	42
Starter Cranking Amps - @ 40° F.....	470

\*Positive and Negative Cables Combined Length

NOTE: This Engine Is Intended For Indoor Installation Or In A Weatherproof Enclosure.

(Continued)  
Page 47-A-1

# DDFP-03DN INSTALLATION & OPERATION DATA (Continued)

<b>Exhaust System</b>	<b>1470</b>	<b>1760</b>	<b>2100</b>	<b>2350</b>	<b>2600</b>	<b>2800</b>	<b>3000</b>
Exhaust Flow - ft. <sup>3</sup> /min. (m <sup>3</sup> /min.).....	404 (11)	498 (14)	576 (16)	646 (18)	710 (20)	762 (22)	818 (23)
Exhaust Temperature - °F (°C).....	810 (432)	850 (454)	840 (449)	840 (449)	845 (452)	855 (457)	860 (460)
Maximum Allowable Back Pressure -							
in. H <sub>2</sub> O (kPa) .....	40 (10.1)	40 (10.1)	40 (10.1)	40 (10.1)	40 (10.1)	40 (10.1)	40 (10.1)
Min. Exhaust Pipe Dia.-in. (mm)** .....		3.0 (76)	3.0 (76)	3.0 (76)	3.0 (76)	3.5 (89)	3.5 (89)

<b>Fuel System</b>							
Fuel Pressure - lb./in. <sup>2</sup> (kPa) .....	65 (448)	68 (469)	70 (482)	72 (496)	74 (510)	75 (517)	76 (524)
Fuel Consumption - gal./hr. (L/hr.) .....	3.2 (12.1)	3.9 (14.8)	4.8 (18.2)	5.3 (20.0)	5.5 (20.8)	5.9 (22.3)	6.1 (23.1)
Fuel Return Rate - gal./hr. (L/hr.) .....	50.0 (189)	50.0 (189)	50.0 (189)	50.0 (189)	50.0 (189)	50.0 (189)	50.0 (189)
Total Fuel Flow - gal./hr. (L/hr.).....	53.2 (201)	53.9 (204)	54.8 (207)	55.3 (209)	55.5 (210)	55.9 (211)	56.1 (212)
Minimum Line Size - Supply - in. (mm)** .....					.50 (13) Sch. 40 - Black		
Minimum Line Size - Return - in. (mm)** .....					.38 (10) Sch. 40 - Black		
Maximum Allowable Fuel Pump Suction							
Clean System - in. H <sub>2</sub> O (kPa) .....					82 (20)		
Dirty System - in. H <sub>2</sub> O (kPa) .....					164 (40)		
Maximum Allowable Head on Fuel Pump - ft. (m) .....					5.0 (1.5)		
Fuel Filter Micron Size - Primary.....					30		
Secondary .....					10		
Fuel Injector/Timing - in. (mm).....					1.490 (37.846)		
Fuel Modulator/Setting .....					None		

<b>Heater System</b>	<b>All Speeds</b>
Jacket Water Heater .....	Standard
Wattage (Nominal) .....	1000
Voltage - VAC, 1P .....	115
Optional Voltage - VAC, 1P .....	230
Lube Oil Heater (Required When Ambient Is Below 50°F (10°C)).....	Optional
Wattage.....	125

<b>Induction Air System</b>	<b>1470</b>	<b>1760</b>	<b>2100</b>	<b>2350</b>	<b>2600</b>	<b>2800</b>	<b>3000</b>
Air Cleaner Type .....							
Air Intake Restriction Maximum Limit							
Dirty Air Cleaner - in. H <sub>2</sub> O (kPa) .....	20 (5.0)	20 (5.0)	20 (5.0)	20 (5.0)	20 (5.0)	20 (5.0)	20 (5.0)
Clean Air Cleaner - in. H <sub>2</sub> O (kPa) .....	15 (2.3)	15 (2.3)	15 (2.3)	15 (2.3)	15 (2.3)	15 (2.3)	15 (2.3)
Engine Air Flow - ft. <sup>3</sup> /min. (m <sup>3</sup> /min.) .....	171 (4.8)	204 (5.8)	238 (6.7)	267 (7.6)	292 (8.3)	311 (8.8)	333 (9.4)

<b>Lubrication System</b>	<b>All Speeds</b>
Oil Pressure - normal - lb./in. <sup>2</sup> (kPa) .....	40-70 (276-433)
In Pan Oil Temperature - °F (°C) .....	200-235 (93-113)
Oil Pan Capacity - High - qt. (L) .....	10.5 (9.9)
Low - qt. (L).....	7.5 (7.1)
Total Oil Capacity with Filters - qt. (L).....	12.5 (11.8)

<b>Performance</b>	<b>1470</b>	<b>1760</b>	<b>2100</b>	<b>2350</b>	<b>2600</b>	<b>2800</b>	<b>3000</b>
BMEP - lb./in. <sup>2</sup> (kPa) .....	83 (572)	88 (607)	88 (607)	88 (607)	84 (579)	80 (552)	76 (524)
Piston Speed - ft./min. (m/min.).....	1103 (336)	1320 (402)	1575 (480)	1763 (537)	1950 (594)	2100 (640)	2250 (685)
Noise - dB (A) @ 1m .....			97	98	98.4 (EST)	98.6 (EST)	98.8 (EST)
Smoke - Bosch number .....	10 (3)	10 (3)					
Power Curve .....							CDDA - 5034 - 02

\*\*Based On Nominal System. Flow Analysis Must Be Done To Assure Adherence To System Limitations.  
(Minimum Exhaust Pipe Diameter is based on 15 feet of pipe, one elbow, and a silencer  
pressure drop no greater than one half the max. allowable back pressure.)

# DDFP-03DT INSTALLATION & OPERATION DATA

<b>Basic Engine Description</b>	<b>All Speeds</b>
Engine Manufacturer .....	Detroit Diesel Corp.
Ignition Type .....	Compression (Diesel)
Number of Cylinders .....	3
Bore and Stroke - in. (mm) .....	3.875 x 4.5 (98 x 114)
Displacement - in. <sup>3</sup> (L) .....	159 (2.6)
Compression Ratio .....	18:1
Combustion System .....	Direct Injection
Engine Type .....	Inline, 2 Cycle
Aspiration .....	Turbocharger
Firing Order (CW Rotation) .....	1-3-2
Charge Air Cooling Type .....	None
Blower Type .....	Roots By-Pass
Blower Drive Ratio .....	2.49:1
Rotation (Viewed from Front)	
Clockwise .....	Standard
Counter-Clockwise .....	Consult Factory
Engine Crankcase Vent System .....	Open
Dimensions and Weight	
Length - in. (mm) (From Drive Flange) .....	35.2 (894.3)
Width - in. (mm) .....	29.9 (760.5)
Height - in. (mm) (Above Crankshaft Center Line) .....	31.3 (795.0)
Weight, Dry - lb. (kg) .....	1153 (523)
Wet - lb. (kg) .....	1230 (558)
Installation Drawing .....	D-436

<b>Cooling System</b>	<b>1470</b>	<b>1760</b>	<b>2100</b>	<b>2350</b>	<b>2600</b>	<b>2800</b>	<b>3000</b>
Engine H <sub>2</sub> O Heat - Btu/sec. (kJ/sec.) .....	50 (53)	65 (69)	91 (96)	114 (120)	132 (139)	138 (146)	145 (153)
Engine Radiated Heat - Btu/sec. (kJ/sec.) .....					11.8 (12.4)		
Heat Exchanger Minimum Flow							
60°F Raw H <sub>2</sub> O - gal./min. (L/min.) .....	7 (27)	8 (30)	11 (42)	14 (53)	16 (61)	17 (64)	18 (68)
95°F Raw H <sub>2</sub> O - gal./min. (L/min.) .....	9 (34)	10 (38)	13 (49)	16 (61)	18 (68)	19 (72)	20 (76)
Heat Exchanger Maximum Cooling H <sub>2</sub> O							
Inlet Pressure - lb./in. <sup>2</sup> (kPa) .....					20 (138)		
Flow - gal./min. (L/min.) .....					40 (151)		
Thermostat, Start to Open - °F (°C) .....					170 (77)		
Fully Open - °F (°C) .....					187 (86)		
Engine Coolant Capacity - qt. (L) .....					16 (14)		
Coolant Pressure Cap - lb./in. <sup>2</sup> (kPa) .....					9 (62)		
Maximum Engine H <sub>2</sub> O Temperature - °F (°C) .....					200 (93)		
Minimum Engine H <sub>2</sub> O Temperature - °F (°C) .....					160 (71)		

<b>Electric System - DC</b>	<b>All Speeds</b>
System Voltage (Nominal) .....	12
Battery Capacity for Ambients Above 32°F - CCA @ 0°F .....	640
Voltage (Nominal) .....	12
Qty. per Battery Bank .....	1
SAE size per J537 .....	4D-640
Battery Cable Circuit*, Max Resistance - ohm .....	0.00098
Battery Cable Minimum Size	
0-120 in. Circuit* Length .....	No. 00
121-160 in. Circuit* Length .....	No. 000
161-200 in. Circuit* Length .....	No. 0000
Charging Alternator Output - Amp. ....	42
Starter Cranking Amps - @ 40° F .....	470

\*Positive and Negative Cables Combined Length

NOTE: This Engine Is Intended For Indoor Installation Or In A Weatherproof Enclosure.

(Continued)  
Page 47-B-1

# DDFP-03DT INSTALLATION & OPERATION DATA (Continued)

<b>Exhaust System</b>	<b>1470</b>	<b>1760</b>	<b>2100</b>	<b>2350</b>	<b>2600</b>	<b>2800</b>	<b>3000</b>
Exhaust Flow - ft. <sup>3</sup> /min. (m <sup>3</sup> /min.).....	750 (21)	700 (20)	835 (24)	910 (26)	970 (27)	1055 (30)	1120 (32)
Exhaust Temperature - °F (°C).....	800 (427)	750 (399)	735 (391)	735 (391)	740 (393)	760 (404)	770 (410)
Maximum Allowable Back Pressure - in. H <sub>2</sub> O (kPa) .....	20 (5.0)	20 (5.0)	28 (7.0)	35 (8.8)	37 (9.3)	37 (9.3)	37 (9.3)
Minimum Exhaust Pipe Dia. - in. (mm)** ....	3.5 (89)	3.5 (89)	3.5 (89)	3.5 (89)	4.0 (102)	4.0 (102)	4.0 (102)

<b>Fuel System</b>							
Fuel Pressure - lb./in. <sup>2</sup> (kPa) .....	66 (455)	68 (469)	70 (482)	72 (496)	74 (510)	75 (517)	76 (524)
Fuel Consumption - gal./hr. (L/hr.) .....	4.6 (17.4)	5.4 (20.4)	6.2 (23.4)	6.7 (25.3)	7.3 (27.6)	8.2 (31.0)	8.3 (31.4)
Fuel Return Rate - gal./hr. (L/hr.) .....	50.0 (189)	50.0 (189)	50.0 (189)	50.0 (189)	50.0 (189)	50.0 (189)	50.0 (189)
Total Fuel Flow - gal./hr. (L/hr.).....	54.6 (206)	55.4 (209)	56.2 (212)	56.7 (214)	57.3 (217)	58.2 (220)	58.3 (220)
Minimum Line Size - Supply - in. (mm)** .....					.50 (13)	Sch. 40 - Black	
Return - in. (mm)** .....					.38 (10)	Sch. 40 - Black	
Maximum Allowable Fuel Pump Suction Clean System - in. H <sub>2</sub> O (kPa) .....					82 (20)		
Dirty System - in. H <sub>2</sub> O (kPa) .....					164 (40)		
Maximum Allowable Head on Fuel Pump - ft. (m) .....					5.0 (1.5)		
Fuel Filter Micron Size - Primary.....					30		
Secondary.....					10		
Fuel Injector/Timing - in. (mm).....					5E60/1.480 (37.592)		
Fuel Modulator/Setting .....					None		

<b>Heater System</b>	<b>All Speeds</b>
Jacket Water Heater .....	Standard
Wattage (Nominal) .....	1000
Voltage - VAC, 1P .....	115
Optional Voltage - VAC, 1P .....	230
Lube Oil Heater (Required When Ambient Is Below 50°F (10°C)).....	Optional
Wattage.....	125

<b>Induction Air System</b>	<b>1470</b>	<b>1760</b>	<b>2100</b>	<b>2350</b>	<b>2600</b>	<b>2800</b>	<b>3000</b>
Air Cleaner Type .....	Indoors Service Only - Washable						
Air Intake Restriction Maximum Limit							
Dirty Air Cleaner - in. H <sub>2</sub> O (kPa) .....	10 (2.5)	11 (2.8)	13 (3.3)	15 (3.8)	16 (4.0)	17 (4.3)	18 (4.5)
Clean Air Cleaner - in. H <sub>2</sub> O (kPa) .....	8 (2.0)	9 (2.3)	11 (2.8)	13 (3.3)	14 (3.5)	15 (3.8)	16 (4.0)
Engine Air Flow - ft. <sup>3</sup> /min. (m <sup>3</sup> /min.) .....	320 (9.0)	340 (9.6)	405 (11)	445 (13)	480 (14)	502 (14)	515 (15)

<b>Lubrication System</b>	<b>All Speeds</b>
Oil Pressure - normal - lb./in. <sup>2</sup> (kPa) .....	40-70 (276-433)
In Pan Oil Temperature - °F (°C) .....	230-245 (110-118)
Oil Pan Capacity - High - qt. (L) .....	10.5 (9.9)
Low - qt. (L).....	7.5 (7.1)
Total Oil Capacity with Filters - qt. (L).....	12.5 (11.8)

<b>Performance</b>	<b>1470</b>	<b>1760</b>	<b>2100</b>	<b>2350</b>	<b>2600</b>	<b>2800</b>	<b>3000</b>
BMEP - lb./in. <sup>2</sup> (kPa) .....	120 (827)	132 (910)	133 (917)	129 (889)	121 (834)	116 (799)	108 (744)
Piston Speed - ft./min. (m/min.).....	1102 (336)	1320 (402)	1575 (480)	1763 (537)	1950 (594)	2100 (640)	2250 (6851)
Noise - dB (A) @ 1m .....		94 (EST)	97	98	98.4 (EST)	98.6 (EST)	98.8 (EST)
Smoke - Bosch number .....		1.6	0.8	0.6	0.6	0.5	0.5
Power Curve .....					CDDA - 5034 - 01		

\*\*Based On Nominal System. Flow Analysis Must Be Done To Assure Adherence To System Limitations.  
(Minimum Exhaust Pipe Diameter is based on 15 feet of pipe, one elbow, and a silencer  
pressure drop no greater than one half the max. allowable back pressure.)

\*\*\*Review For Power Deration If Air Entering Engine Exceeds 77° F (25° C).

# DDFP-L3DT INSTALLATION & OPERATION DATA

## Basic Engine Description

## All Speeds

Engine Manufacturer .....	Detroit Diesel Corp.
Ignition Type .....	Compression (Diesel)
Number of Cylinders .....	3
Bore and Stroke - in. (mm) .....	3.875 x 4.5 (98 x 114)
Displacement - in. <sup>3</sup> (L) .....	159 (2.6)
Compression Ratio .....	18:1
Combustion System .....	Direct Injection
Engine Type .....	Inline, 2 Cycle
Aspiration .....	Turbocharger
Firing Order (CW Rotation) .....	1-3-2
Charge Air Cooling Type .....	None
Blower Type .....	Roots By-Pass
Blower Drive Ratio .....	2.49:1
Rotation (Viewed from Front)	
Clockwise .....	Standard
Counter-Clockwise .....	Consult Factory
Engine Crankcase Vent System .....	Open
Dimensions and Weight	
Length - in. (mm) (From Drive Flange) .....	35.2 (894.3)
Width - in. (mm) .....	29.9 (760.5)
Height - in. (mm) (Above Crankshaft Center Line) .....	31.3 (795.0)
Weight, Dry - lb. (kg) .....	1159 (526)
Wet - lb. (kg) .....	1236 (561)
Installation Drawing .....	D-436

## Cooling System

## 2600      2800      3000

Engine H <sub>2</sub> O Heat - Btu/sec. (kJ/sec.) .....	169 (178)	175 (185)	178 (188)
Engine Radiated Heat - Btu/sec. (kJ/sec.) .....	12.7 (13.4)		
Heat Exchanger Minimum Flow			
60°F Raw H <sub>2</sub> O - gal./min. (L/min.) .....	21 (79)	22 (83)	22 (83)
95°F Raw H <sub>2</sub> O - gal./min. (L/min.) .....	23 (87)	24 (91)	24 (91)
Heat Exchanger Maximum Cooling H <sub>2</sub> O			
Inlet Pressure - lb./in. <sup>2</sup> (kPa) .....	20 (138)		
Flow - gal./min. (L/min.) .....	40 (151)		
Thermostat, Start to Open - °F (°C) .....	170 (77)		
Fully Open - °F (°C) .....	187 (86)		
Engine Coolant Capacity - qt. (L) .....	16 (14)		
Coolant Pressure Cap - lb./in. <sup>2</sup> (kPa) .....	9 (62)		
Maximum Engine H <sub>2</sub> O Temperature - °F (°C) .....	200 (93)		
Minimum Engine H <sub>2</sub> O Temperature - °F (°C) .....	160 (71)		

## Electric System - DC

## All Speeds

System Voltage (Nominal) .....	12
Battery Capacity for Ambients Above 32°F - CCA @ 0°F .....	640
Voltage (Nominal) .....	12
Qty. per Battery Bank .....	1
SAE size per J537 .....	4D-640
Battery Cable Circuit*, Max Resistance - ohm .....	0.00098
Battery Cable Minimum Size	
0-120 in. Circuit* Length .....	No. 00
121-160 in. Circuit* Length .....	No. 000
161-200 in. Circuit* Length .....	No. 0000
Charging Alternator Output - Amp. ....	42
Starter Cranking Amps - @ 40° F .....	470

(Continued)



# DDFP-L3DT INSTALLATION & OPERATION DATA (Continued)

## **Exhaust System**

	<b>2600</b>	<b>2800</b>	<b>3000</b>
Exhaust Flow - ft. <sup>3</sup> /min. (m <sup>3</sup> /min.) .....	1176 (33)	1251 (35)	1307 (37)
Exhaust Temperature - °F (°C).....	845 (452)	850 (457)	840 (461)
Maximum Allowable Back Pressure - in. H <sub>2</sub> O (kPa) .....	37 (9.3)	37 (9.3)	37 (9.3)
Minimum Exhaust Pipe Dia. - in. (mm)** .....	4.0 (102)	4.0 (102)	4.0 (102)

## **Fuel System**

Fuel Pressure - lb./in. <sup>2</sup> (kPa) .....	74 (510)	75 (517)	76 (524)
Fuel Consumption - gal./hr. (L/hr.) .....	9.8 (37)	10.5 (40)	10.1 (38)
Fuel Return Rate - gal./hr. (L/hr.) .....	50.0 (189)	50.0 (189)	50.0 (189)
Total Fuel Flow - gal./hr. (L/hr.) .....	59.8 (226)	60.5 (229)	60.1 (227)
Minimum Line Size - Supply - in. (mm)** .....	.50 (13) Sch. 40 - Black		
return - in. (mm)** .....	.38 (10) Sch. 40 - Black		
Maximum Allowable Fuel Pump Suction			
Clean System - in. H <sub>2</sub> O (kPa) .....	82 (20)		
Dirty System - in. H <sub>2</sub> O (kPa) .....	164 (40)		
Maximum Allowable Head on Fuel Pump - ft. (m) .....	5.0 (1.5)		
Fuel Filter Micron Size - Primary.....	30		
Secondary.....	10		
Fuel Injector/Timing - in. (mm).....	6840/1.520 (38.608)		
Fuel Modulator/Setting .....	None		

## **Heater System**

### **All Speeds**

Jacket Water Heater .....	Standard
Wattage (Nominal) .....	1000
Voltage - VAC, 1P .....	115
Optional Voltage - VAC, 1P .....	230
Lube Oil Heater (Required When Ambient Is Below 50°F (10°C)).....	Optional
Wattage.....	125

## **Induction Air System**

### **2600            2800            3000**

Air Cleaner Type .....	Indoors Service Only - Washable		
Air Intake Restriction Maximum Limit			
Dirty Air Cleaner - in. H <sub>2</sub> O (kPa) .....	16 (4.0)	17 (4.3)	17 (4.3)
Clean Air Cleaner - in. H <sub>2</sub> O (kPa).....	14 (3.5)	15 (3.8)	15 (3.8)
Engine Air Flow - ft. <sup>3</sup> /min. (m <sup>3</sup> /min.) .....	484 (14)	513 (15)	540 (15)
Maximum Allowable Temperature Rise (Ambient Air To Engine Inlet) - °F (°C).....	30 (17)		

## **Lubrication System**

### **All Speeds**

Oil Pressure - normal - lb./in. <sup>2</sup> (kPa) .....	40-70 (276-433)
In Pan Oil Temperature - °F (°C) .....	230-245 (110-118)
Oil Pan Capacity - High - qt. (L) .....	10.5 (9.9)
Low - qt. (L).....	7.5 (7.1)
Total Oil Capacity with Filters - qt. (L).....	12.5 (11.8)

## **Performance**

### **2600            2800            3000**

BMEP - lb./in. <sup>2</sup> (kPa) .....	154 (1055)	147 (1014)	133 (917)
Piston Speed - ft./min. (m/min.) .....	1950 (594)	2100 (640)	2250 (685)
Noise - dB (A) @ 1m .....	99.4 (EST)	99.6 (EST)	99.8 (EST)
Power Curve .....	CDDA - 5034 - 03		

\*\*Based On Nominal System. Flow Analysis Must Be Done To Assure Adherence To System Limitations.  
(Minimum Exhaust Pipe Diameter is based on 15 feet of pipe, one elbow, and a silencer  
pressure drop no greater than one half the max. allowable back pressure.)

# DDFP-T3DT INSTALLATION & OPERATION DATA

## Basic Engine Description

## All Speeds

Engine Manufacturer .....	Detroit Diesel Corp.						
Ignition Type .....	Compression (Diesel)						
Number of Cylinders .....	3						
Bore and Stroke - in. (mm) .....	3.875 x 4.5 (98 x 114)						
Displacement - in. <sup>3</sup> (L) .....	159 (2.6)						
Compression Ratio .....	18:1						
Combustion System .....	Direct Injection						
Engine Type .....	Inline, 2 Cycle						
Aspiration .....	Turbocharger						
Firing Order (CW Rotation) .....	1-3-2						
Charge Air Cooling Type .....	None						
Blower Type .....	Roots By-Pass						
Blower Drive Ratio .....	2.49:1						
Rotation (Viewed from Front)							
Clockwise .....	Standard						
Counter-Clockwise .....	Consult Factory						
Engine Crankcase Vent System .....	Open						
Dimensions and Weight							
Length - in. (mm) (From Drive Flange) .....	35.2 (894.3)						
Width - in. (mm) .....	29.9 (760.5)						
Height - in. (mm) (Above Crankshaft Center Line) .....	31.3 (795.0)						
Weight, Dry - lb. (kg) .....	1159 (526)						
Wet - lb. (kg) .....	1236 (561)						
Installation Drawing .....	D-436						

## Cooling System

**1470      1760      2100      2350      2600      2800      3000**

Engine H <sub>2</sub> O Heat - Btu/sec. (kJ/sec.) .....	61 (64)	79 (83)	111 (117)	141 (149)	170 (179)	179 (189)	195 (205)
Engine Radiated Heat - Btu/sec. (kJ/sec.) .....	12.7 (13.4)						
Heat Exchanger Minimum Flow							
60°F Raw H <sub>2</sub> O - gal./min. (L/min.) .....	9.0 (34)	10 (38)	14 (53)	18 (68)	21 (79)	22 (83)	24 (91)
95°F Raw H <sub>2</sub> O - gal./min. (L/min.) .....	11 (42)	12 (45)	16 (61)	20 (76)	23 (87)	25 (95)	27 (102)
Heat Exchanger Maximum Cooling H <sub>2</sub> O							
Inlet Pressure - lb./in. <sup>2</sup> (kPa) .....	20 (138)						
Flow - gal./min. (L/min.) .....	40 (151)						
Thermostat, Start to Open - °F (°C) .....	170 (77)						
Fully Open - °F (°C) .....	187 (86)						
Engine Coolant Capacity - qt. (L) .....	16 (14)						
Coolant Pressure Cap - lb./in. <sup>2</sup> (kPa) .....	9 (62)						
Maximum Engine H <sub>2</sub> O Temperature - °F (°C) .....	200 (93)						
Minimum Engine H <sub>2</sub> O Temperature - °F (°C) .....	160 (71)						

## Electric System - DC

## All Speeds

System Voltage (Nominal) .....	12
Battery Capacity for Ambients Above 32°F - CCA @ 0°F .....	640
Voltage (Nominal) .....	12
Qty. per Battery Bank .....	1
SAE size per J537 .....	4D-640
Battery Cable Circuit*, Max Resistance - ohm .....	0.00098
Battery Cable Minimum Size	
0-120 in. Circuit* Length .....	No. 00
121-160 in. Circuit* Length .....	No. 000
161-200 in. Circuit* Length .....	No. 0000
Charging Alternator Output - Amp. .....	42
Starter Cranking Amps - @ 40° F .....	470

# DDFP-T3DT

## INSTALLATION & OPERATION DATA (Continued)

<b>Exhaust System</b>	<b>1470</b>	<b>1760</b>	<b>2100</b>	<b>2350</b>	<b>2600</b>	<b>2800</b>	<b>3000</b>
Exhaust Flow - ft. <sup>3</sup> /min. (m <sup>3</sup> /min.).....	738 (21)	881 (25)	1001 (28)	1068 (30)	1182 (33)	1256 (36)	1347 (38)
Exhaust Temperature - °F (°C).....	807 (431)	818 (437)	829 (443)	838 (448)	847 (453)	854 (457)	862 (461)
Maximum Allowable Back Pressure - in. H <sub>2</sub> O (kPa) .....	20 (5.0)	20 (5.0)	28 (7.0)	35 (8.8)	37 (9.3)	37 (9.3)	37 (9.3)
Minimum Exhaust Pipe Dia. - in. (mm)** .....	4.0 (102)	4.0 (102)	4.0 (102)	4.0 (102)	4.0 (102)	4.0 (102)	4.0 (102)

<b>Fuel System</b>							
Fuel Pressure - lb./in. <sup>2</sup> (kPa) .....	66 (455)	68 (469)	70 (482)	72 (496)	74 (510)	75 (517)	76 (524)
Fuel Consumption - gal./hr. (L/hr.) .....	6.0 (22.7)	7.2 (27.3)	7.7 (29.1)	8.8 (33.3)	9.8 (37.1)	10.7 (40.5)	11.2 (42.4)
Fuel Return Rate - gal./hr. (L/hr.) .....	50.0 (189)	50.0 (189)	50.0 (189)	50.0 (189)	50.0 (189)	50.0 (189)	50.0 (189)
Total Fuel Flow - gal./hr. (L/hr.).....	56.0 (211)	57.2 (216)	57.7 (218)	58.8 (221)	59.8 (226)	60.7 (230)	61.2 (231)
Minimum Line Size - Supply - in. (mm)** .....					.50 (13)	Sch. 40 - Black	
Return - in. (mm)** .....					.38 (10)	Sch. 40 - Black	
Maximum Allowable Fuel Pump Suction Clean System - in. H <sub>2</sub> O (kPa) .....					82 (20)		
Dirty System - in. H <sub>2</sub> O (kPa) .....					164 (40)		
Maximum Allowable Head on Fuel Pump - ft. (m) .....					5.0 (1.5)		
Fuel Filter Micron Size - Primary.....					30		
Secondary.....					10		
Fuel Injector/Timing - in. (mm).....					6840/1.520 (38.608)		
Fuel Modulator/Setting .....					None		

<b>Heater System</b>	<b>All Speeds</b>
Jacket Water Heater .....	Standard
Wattage (Nominal) .....	1000
Voltage - VAC, 1P .....	115
Optional Voltage - VAC, 1P .....	230
Lube Oil Heater (Required When Ambient Is Below 50°F (10°C)).....	Optional
Wattage.....	125

<b>Induction Air System</b>	<b>1470</b>	<b>1760</b>	<b>2100</b>	<b>2350</b>	<b>2600</b>	<b>2800</b>	<b>3000</b>
Air Cleaner Type .....	ors Service Only - Washable						
Air Intake Restriction Maximum Limit Dirty Air Cleaner - in. H <sub>2</sub> O (kPa) .....	10 (2.5)	11 (2.8)	13 (3.3)	15 (3.8)	16 (4.0)	17 (4.3)	18 (4.5)
Clean Air Cleaner - in. H <sub>2</sub> O (kPa) .....	8 (2.0)	9 (2.3)	11 (2.8)	13 (3.3)	14 (3.5)	15 (3.8)	16 (4.0)
Engine Air Flow - ft. <sup>3</sup> /min. (m <sup>3</sup> /min.) .....	313 (8.8)	370 (10)	417 (12)	442 (13)	486 (14)	517 (15)	547 (15)
Maximum Allowable Temperature Rise (Ambient Air To Engine Inlet) - °F (°C).....					30 (17)		

<b>Lubrication System</b>	<b>All Speeds</b>
Oil Pressure - normal - lb./in. <sup>2</sup> (kPa) .....	40-70 (276-433)
In Pan Oil Temperature - °F (°C) .....	230-245 (110-118)
Oil Pan Capacity - High - qt. (L) .....	10.5 (9.9)
Low - qt. (L).....	7.5 (7.1)
Total Oil Capacity with Filters - qt. (L).....	12.5 (11.8)

<b>Performance</b>	<b>1470</b>	<b>1760</b>	<b>2100</b>	<b>2350</b>	<b>2600</b>	<b>2800</b>	<b>3000</b>
BMEP - lb./in. <sup>2</sup> (kPa) .....	145 (1000)	160 (1103)	161 (1110)	159 (1096)	154 (1062)	150 (1034)	145 (1000)
Piston Speed - ft./min. (m/min.).....	1102 (336)	1320 (402)	1575 (480)	1763 (537)	1950 (594)	2100 (640)	2250 (685)
Noise - dB (A) @ 1m .....	93.5 (EST)	95 (EST)	98 (EST)	99 (EST)	99.4 (EST)	99.6 (EST)	99.8 (EST)
Power Curve .....	CDDA - 5034 - 03						

\*\*Based On Nominal System. Flow Analysis Must Be Done To Assure Adherence To System Limitations.  
(Minimum Exhaust Pipe Diameter is based on 15 feet of pipe, one elbow, and a silencer  
pressure drop no greater than one half the max. allowable back pressure.)

# DDFP-L6FA INSTALLATION & OPERATION DATA

<b>Basic Engine Description</b>	<b>All Speeds</b>			
Engine Manufacturer .....	Detroit Diesel Corp.			
Ignition Type .....	Compression (Diesel)			
Number of Cylinders .....	6			
Bore and Stroke - in. (mm).....	4.84 x 5.00 (123 x 127)			
Displacement - in. <sup>3</sup> (L).....	552 (9.1)			
Compression Ratio .....	17:1			
Combustion System .....	Direct Injection			
Engine Type.....	63.5° VEE - 2 Cycle			
Aspiration .....	Turbocharged			
Firing Order (CW Rotation).....	1R-1L-3R-3L-2R-2L			
Charge Air Cooling Type .....	Jacket Water			
Blower Type .....	Roots By-Pass			
Blower Drive Ratio .....	1.95:1			
Rotation (Viewed from Front)				
Clockwise .....	Standard			
Counter-Clockwise .....	Optional			
Engine Crankcase Vent System.....	Open			
Dimensions and Weight				
Length - in. (mm) (From Drive Flange).....	45.35 (1152)			
Width - in. (mm).....	40.34 (1025)			
Height - in. (mm) (Above Crankshaft Center Line) .....	43.75 (1111)			
Weight, Dry - lb. (kg) .....	2217 (1005)			
Wet - lb. (kg) .....	2325 (1055)			
Installation Drawing .....	D-433			
<b>Cooling System</b>	<b>1470</b>	<b>1760</b>	<b>2100</b>	<b>2350</b>
Engine H <sub>2</sub> O Heat - Btu/sec. (kJ/sec.) .....	90 (95)	138 (146)	157 (166)	175 (185)
Engine Radiated Heat - Btu/sec. (kJ/sec.).....		42 (44)		
Heat Exchanger Minimum Flow				
60°F Raw H <sub>2</sub> O - gal./min. (L/min.) .....	9 (34)	13 (49)	17 (64)	18 (68)
95°F Raw H <sub>2</sub> O - gal./min. (L/min.) .....	14 (53)	17 (64)	23 (87)	25 (95)
Heat Exchanger Maximum Cooling H <sub>2</sub> O				
Inlet Pressure - lb./in. <sup>2</sup> (kPa) .....		60 (414)		
Flow - gal./min. (L/min.) .....		50 (189)		
Thermostat, Start to Open - °F (°C) .....		177 (81)		
Fully Open - °F (°C) .....		197 (92)		
Engine Coolant Capacity - qt. (L) .....		43 (41)		
Coolant Pressure Cap - lb./in. <sup>2</sup> (kPa) .....		9 (62)		
Maximum Engine H <sub>2</sub> O Temperature - °F (C) .....		200 (93)		
Minimum Engine H <sub>2</sub> O Temperature - °F (°C).....		160 (71)		
<b>Electric System - DC</b>	<b>All Speeds</b>			
System Voltage (Nominal) .....	24			
Battery Capacity for Ambients Above 32°F - CCA @ 0°F .....	900			
Voltage (Nominal) .....	12			
Qty. per Battery Bank .....	2			
SAE size per J537 .....	8D-900			
Battery Cable Circuit*, Max Resistance - ohm .....	0.002			
Battery Cable Minimum Size				
0-225 in. Circuit* Length .....	No. 00			
225-300 in. Circuit* Length .....	No. 000			
301-380 in. Circuit* Length .....	No. 0000			
Charging Alternator Output - Amp. ....	40			
Starter Cranking Amps - @ 40° F .....	595			

# DDFP-L6FA INSTALLATION & OPERATION DATA (Continued)

<b>Exhaust System</b>	<b>1470</b>	<b>1760</b>	<b>2100</b>	<b>2350</b>
Exhaust Flow - ft. <sup>3</sup> /min. (m <sup>3</sup> /min.) .....	1570 (44)	1930 (55)	2320 (66)	2440 (69)
Exhaust Temperature - °F (°C) .....	723 (383)	680 (360)	649 (343)	639 (337)
Maximum Allowable Back Pressure - in. H <sub>2</sub> O (kPa) .....	19 (4.7)	26 (6.6)	28 (7.1)	30 (7.6)
Minimum Exhaust Pipe Dia. - in. (mm)** .....	5 (127)	5 (127)	6 (152)	6 (152)

<b>Fuel System</b>				
Fuel Pressure - lb./in. <sup>2</sup> (kPa) .....	58 (400)	62 (428)	64 (442)	65 (449)
Fuel Consumption - gal./hr. (L/hr.) .....	12 (45)	14 (53)	17 (64)	17 (64)
Fuel Return Rate - gal./hr. (L/hr.) .....	63 (239)	71 (269)	80 (303)	83 (315)
Total Fuel Flow - gal./hr. (L/hr.) .....	75 (284)	85 (322)	97 (367)	100 (379)
Minimum Line Size - Supply - in. (mm)** .....		.75 (19) Sch. 40 - Black		
Return - in. (mm)** .....		.50 (13) Sch. 40 - Black		
Maximum Allowable Fuel Pump Suction				
Clean System - in. H <sub>2</sub> O (kPa) .....		82 (20)		
Dirty System - in. H <sub>2</sub> O (kPa) .....		164 (40)		
Maximum Allowable Head on Fuel Pump - ft(m) .....		5.0 (1.5)		
Fuel Filter Micron Size - Primary .....		30		
Secondary .....		12		
Fuel Injector/Timing .....		9225/1.490		
Fuel Modulator/Setting .....		None		

<b>Heater System</b>	<b>All Speeds</b>
Jacket Water Heater .....	Standard
Wattage (Nominal) .....	2500
Voltage - VAC, 1P .....	230
Optional Voltage - VAC, 1P .....	115
Lube Oil Heater (Required When Ambient Is Below 50°F (10°C)) .....	Optional
Wattage .....	125

<b>Induction Air System</b>	<b>1470</b>	<b>1760</b>	<b>2100</b>	<b>2350</b>
Air Cleaner Type .....	Indoors Service Only - Washable			
Air Intake Restriction Maximum Limit				
Dirty Air Cleaner - in. H <sub>2</sub> O (kPa) .....	6.5 (1.7)	7.0 (1.8)	8.0 (2.0)	9.0 (2.3)
Clean Air Cleaner - in. H <sub>2</sub> O (kPa) .....	3.3 (0.8)	4.3 (1.1)	5.8 (1.4)	6.5 (1.6)
Engine Air Flow - ft. <sup>3</sup> /min. (m <sup>3</sup> /min.) .....	760 (22)	875 (25)	990 (28)	1060 (30)
Maximum Allowable Temperature (Ambient Air To Engine Inlet) - °F (°C) .....		30 (17)		

<b>Lubrication System</b>	<b>All Speeds</b>
Oil Pressure - normal - lb./in. <sup>2</sup> (kPa) .....	40-70 (276-433)
In Pan Oil Temperature - °F (°C) .....	190-220 (88-104)
Oil Pan Capacity - High - qt. (L) .....	20 (19)
Low - qt. (L) .....	16 (15)
Total Oil Capacity with Filters - qt. (L) .....	22 (21)

<b>Performance</b>	<b>1470</b>	<b>1760</b>	<b>2100</b>	<b>2350</b>
BMEP - lb./in. <sup>2</sup> (kPa) .....	106 (731)	108 (745)	104 (717)	95 (655)
Piston Speed - ft./min. (m/min.) .....	1225 (373)	1467 (447)	1750 (533)	1958 (597)
Noise - dB (A) @ 1m .....	95 (EST)	96 (EST)	98 (EST)	98 (EST)
Power Curve .....		CDDA - 8064 - 03		

\*\*Based On Nominal System. Flow Analysis Must Be Done To Assure Adherence To System Limitations.  
(Minimum Exhaust Pipe Diameter is based on 15 feet of pipe, one elbow, and a silencer  
pressure drop no greater than one half the max. allowable back pressure.)

# DDFP-T6FA INSTALLATION & OPERATION DATA

## Basic Engine Description

## All Speeds

Engine Manufacturer .....	Detroit Diesel Corp.
Ignition Type .....	Compression (Diesel)
Number of Cylinders .....	6
Bore and Stroke - in. (mm) .....	4.84 x 5.00 (123 x 127)
Displacement - in. <sup>3</sup> (L) .....	552 (9.1)
Compression Ratio .....	17:1
Combustion System .....	Direct Injection
Engine Type .....	63.5° VEE - 2 Cycle
Aspiration .....	Turbocharged
Firing Order (CW Rotation) .....	1R-1L-3R-3L-2R-2L
Charge Air Cooling Type .....	Jacket Water
Blower Type .....	Roots By-Pass
Blower Drive Ratio .....	1.95:1
Rotation (Viewed from Front)	
Clockwise .....	Standard
Counter-Clockwise .....	Optional
Engine Crankcase Vent System .....	Open
Dimensions and Weight	
Length - in. (mm) (From Drive Flange) .....	45.35 (1152)
Width - in. (mm) .....	40.34 (1025)
Height - in. (mm) (Above Crankshaft Center Line) .....	43.75 (1111)
Weight, Dry - lb. (kg) .....	2217 (1005)
Wet - lb. (kg) .....	2325 (1055)
Installation Drawing .....	D-433

## Cooling System

**1470      1760      2100      2350**

Engine H <sub>2</sub> O Heat - Btu/sec. (kJ/sec.) .....	145 (153)	170 (179)	180 (190)	206 (217)
Engine Radiated Heat - Btu/sec. (kJ/sec.) .....		42 (44)		
Heat Exchanger Minimum Flow				
60°F Raw H <sub>2</sub> O - gal./min. (L/min.) .....	11 (42)	14 (53)	18 (68)	20 (76)
95°F Raw H <sub>2</sub> O - gal./min. (L/min.) .....	18 (68)	19 (72)	27 (102)	32 (121)
Heat Exchanger Maximum Cooling H <sub>2</sub> O				
Inlet Pressure - lb./in. <sup>2</sup> (kPa) .....		60 (414)		
Flow - gal./min. (L/min.) .....		50 (189)		
Thermostat, Start to Open - °F (°C) .....		177 (81)		
Fully Open - °F (°C) .....		197 (92)		
Engine Coolant Capacity - qt. (L) .....		43 (41)		
Coolant Pressure Cap - lb./in. <sup>2</sup> (kPa) .....		9 (62)		
Maximum Engine H <sub>2</sub> O Temperature - °F (°C) .....		200 (93)		
Minimum Engine H <sub>2</sub> O Temperature - °F (°C) .....		160 (71)		

## Electric System - DC

## All Speeds

System Voltage (Nominal) .....	24
Battery Capacity for Ambients Above 32°F - CCA @ 0°F .....	900
Voltage (Nominal) .....	12
Qty. per Battery Bank .....	2
SAE size per J537 .....	8D-900
Battery Cable Circuit*, Max Resistance - ohm .....	0.002
Battery Cable Minimum Size	
0-225 in. Circuit* Length .....	No. 00
225-300 in. Circuit* Length .....	No. 000
301-380 in. Circuit* Length .....	No. 0000
Charging Alternator Output - Amp. ....	40
Starter Cranking Amps - @ 40° F .....	595

(Continued)

# DDFP-T6FA INSTALLATION & OPERATION DATA (Continued)

## Exhaust System

	<u>1470</u>	<u>1760</u>	<u>2100</u>	<u>2350</u>
Exhaust Flow - ft. <sup>3</sup> /min. (m <sup>3</sup> /min.) .....	1950 (44)	2150 (61)	2350 (66)	2660 (75)
Exhaust Temperature - °F (°C) .....	766 (408)	708 (376)	689 (365)	668 (353)
Maximum Allowable Back Pressure - in. H <sub>2</sub> O (kPa) .....	19 (4.7)	26 (6.6)	28 (7.1)	30 (7.6)
Minimum Exhaust Pipe Dia. - in. (mm)** .....	Single 6.0 (152) Sch. 40			

## Fuel System

Fuel Pressure - lb./in. <sup>2</sup> (kPa) .....	58 (400)	62 (428)	64 (442)	65 (449)
Fuel Consumption - gal./hr. (L/hr.) .....	15 (57)	16 (61)	19 (72)	20 (76)
Fuel Return Rate - gal./hr. (L/hr.) .....	63 (239)	71 (269)	80 (303)	83 (315)
Total Fuel Flow - gal./hr. (L/hr.) .....	78 (295)	87 (329)	99 (375)	103 (390)
Minimum Line Size - Supply - in. (mm)** .....	.75 (19) Sch. 40 - Black			
Return - in. (mm)** .....	.50 (13) Sch. 40 - Black			
Maximum Allowable Fuel Pump Suction				
Clean System - in. H <sub>2</sub> O (kPa) .....	82 (20)			
Dirty System - in. H <sub>2</sub> O (kPa) .....	164 (40)			
Maximum Allowable Head on Fuel Pump - ft(m) .....	5.0 (1.5)			
Fuel Filter Micron Size - Primary .....	30			
Secondary .....	12			
Fuel Injector/Timing .....	9225/1.490			
Fuel Modulator/Setting .....	None			

## Heater System

### All Speeds

Jacket Water Heater .....	Standard
Wattage (Nominal) .....	2500
Voltage - VAC, 1P .....	230
Optional Voltage - VAC, 1P .....	115
Lube Oil Heater (Required When Ambient Is Below 50°F (10°C)) .....	Optional
Wattage .....	125

## Induction Air System

### 1470      1760      2100      2350

Air Cleaner Type .....	Indoors Service Only - Washable			
Air Intake Restriction Maximum Limit				
Dirty Air Cleaner - in. H <sub>2</sub> O (kPa) .....	6.5 (1.7)	7.0 (1.8)	8.0 (2.0)	9.0 (2.3)
Clean Air Cleaner - in. H <sub>2</sub> O (kPa) .....	4.5 (1.1)	5.0 (1.3)	6.0 (1.5)	7.0 (1.8)
Engine Air Flow - ft. <sup>3</sup> /min. (m <sup>3</sup> /min.) .....	900 (25)	960 (27)	1050 (30)	1092 (31)
Maximum Allowable Temperature (Ambient Air To Engine Inlet) - °F (°C) .....	30 (17)			

## Lubrication System

### All Speeds

Oil Pressure - normal - lb./in. <sup>2</sup> (kPa) .....	40-70 (276-433)
In Pan Oil Temperature - °F (°C) .....	190-220 (88-104)
Oil Pan Capacity - High - qt. (L) .....	20 (19)
Low - qt. (L) .....	16 (15)
Total Oil Capacity with Filters - qt. (L) .....	22 (21)

## Performance

### 1470      1760      2100      2350

BMEP - lb./in. <sup>2</sup> (kPa) .....	124 (855)	123 (848)	116 (800)	106 (731)
Piston Speed - ft./min. (m/min.) .....	1225 (373)	1467 (447)	1750 (533)	1958 (597)
Noise - dB (A) @ 1m .....	95 (EST)	96 (EST)	99 (EST)	99 (EST)
Power Curve .....	CDDA - 8064 - 04			

\*Based On Nominal System. Flow Analysis Must Be Done To Assure Adherence To System Limitations.  
(Minimum Exhaust Pipe Diameter is based on 15 feet of pipe, one elbow, and a silencer  
pressure drop no greater than one half the max. allowable back pressure.)

# DDFP-06FA INSTALLATION & OPERATION DATA

## Basic Engine Description

Engine Manufacturer .....	Detroit Diesel Corp.
Ignition Type .....	Compression (Diesel)
Number of Cylinders .....	6
Bore and Stroke - in. (mm) .....	4.84 x 5.00 (123 x 127)
Displacement - in. <sup>3</sup> (L) .....	552 (9.1)
Compression Ratio .....	17:1
Combustion System .....	Direct Injection
Engine Type .....	63.5° VEE - 2 Cycle
Aspiration .....	Turbocharged
Firing Order (CW Rotation) .....	1R-1L-3R-3L-2R-2L
Charge Air Cooling Type .....	Jacket Water
Blower Type .....	Roots By-Pass
Blower Drive Ratio .....	1.95:1
Rotation (Viewed from Front)	
Clockwise .....	Standard
Counter-Clockwise .....	Optional
Engine Crankcase Vent System .....	Open
Dimensions and Weight	
Length - in. (mm) (From Drive Flange) .....	45.35 (1152)
Width - in. (mm) .....	40.34 (1025)
Height - in. (mm) (Above Crankshaft Center Line) .....	43.75 (1111)
Weight, Dry - lb. (kg) .....	2217 (1005)
Wet - lb. (kg) .....	2325 (1055)
Installation Drawing .....	D-433

## All Speeds

## Cooling System

	1470	1760	2100	2350
Engine H <sub>2</sub> O Heat - Btu/sec. (kJ/sec.) .....	206 (217)	233 (246)	260 (274)	284 (300)
Engine Radiated Heat - Btu/sec. (kJ/sec.) .....		42 (44)		
Heat Exchanger Minimum Flow				
60°F Raw H <sub>2</sub> O - gal./min. (L/min.) .....	13 (49)	21 (79)	26 (98)	28 (106)
95°F Raw H <sub>2</sub> O - gal./min. (L/min.) .....	22 (83)	32 (121)	39 (148)	42 (159)
Heat Exchanger Maximum Cooling H <sub>2</sub> O				
Inlet Pressure - lb./in. <sup>2</sup> (kPa) .....		60 (44)		
Flow - gal./min. (L/min.) .....		70 (265)		
Thermostat, Start to Open - °F (°C) .....		177 (81)		
Fully Open - °F (°C) .....		197 (92)		
Engine Coolant Capacity - qt. (L) .....		42 (40)		
Coolant Pressure Cap - lb./in. <sup>2</sup> (kPa) .....		9 (62)		
Maximum Engine H <sub>2</sub> O Temperature - °F (°C) .....		200 (93)		
Minimum Engine H <sub>2</sub> O Temperature - °F (°C) .....		160 (71)		

## Electric System - DC

	All Speeds
System Voltage (Nominal) .....	24
Battery Capacity for Ambients Above 32°F - CCA @ 0°F .....	900
Voltage (Nominal) .....	12
Qty. per Battery Bank .....	2
SAE size per J537 .....	8D-900
Battery Cable Circuit*, Max Resistance - ohm .....	0.002
Battery Cable Minimum Size	
0-225 in. Circuit* Length .....	No. 00
225-300 in. Circuit* Length .....	No. 000
301-380 in. Circuit* Length .....	No. 0000
Charging Alternator Output - Amp .....	40
Starter Cranking Amps - @ 40° F .....	595

\*Positive and Negative Cables Combined Length



# DDFP-06FA INSTALLATION & OPERATION DATA (Continued)

<b>Exhaust System</b>	<b>1470</b>	<b>1760</b>	<b>2100</b>	<b>2350</b>
Exhaust Flow - ft. <sup>3</sup> /min. (m <sup>3</sup> /min.).....	2217 (63)	2594 (73)	2987 (85)	3275 (93)
Exhaust Temperature - °F (°C).....	865 (463)	830 (433)	820 (438)	820 (438)
Maximum Allowable Back Pressure - in. H <sub>2</sub> O (kPa).....	19 (4.7)	26 (6.6)	28 (7.1)	30 (7.6)
Minimum Exhaust Pipe Dia. - in. (mm)** .....		Single 6.0 (154) Sch. 40		

<b>Fuel System</b>				
Fuel Pressure - lb./in. <sup>2</sup> (kPa) .....	58 (400)	62 (428)	64 (442)	65 (449)
Fuel Consumption - gal./hr. (L/hr.) .....	17 (64)	20 (75.8)	23 (87)	25 (95)
Fuel Return Rate - gal./hr. (L/hr.) .....	63 (239)	71 (269)	80 (303)	83 (315)
Total Fuel Flow - gal./hr. (L/hr.).....	80 (303)	91 (345)	103 (390)	105 (398)
Minimum Line Size - Supply - in. (mm)** .....		.75 (19) Sch. 40 - Black		
Return - in. (mm)** .....		.50 (13) Sch. 40 - Black		
Maximum Allowable Fuel Pump Suction Clean System - in. H <sub>2</sub> O (kPa).....		82 (20)		
Dirty System - in. H <sub>2</sub> O (kPa) .....		164 (40)		
Maximum Allowable Head on Fuel Pump - ft(m) .....		5.0 (1.5)		
Fuel Filter Micron Size - Primary.....		30		
Secondary .....		12		
Fuel Injector/Timing .....		9225/1.490		
Fuel Modulator/Setting .....		None		

<b>Heater System</b>	<b>All Speeds</b>
Jacket Water Heater .....	Standard
Wattage (Nominal) .....	2500
Voltage - VAC, 1P .....	230
Optional Voltage - VAC, 1P .....	115
Lube Oil Heater (Required When Ambient Is Below 50°F (10°C)).....	Optional
Wattage.....	125

<b>Induction Air System</b>	<b>1470</b>	<b>1760</b>	<b>2100</b>	<b>2350</b>
Air Cleaner Type .....	Indoors Service Only - Washable			
Air Intake Restriction Maximum Limit Dirty Air Cleaner - in. H <sub>2</sub> O (kPa).....	6.5 (1.7)	7.0 (1.8)	8.0 (2.0)	9.0 (2.3)
Clean Air Cleaner - in. H <sub>2</sub> O (kPa) .....	4.5 (1.1)	5.0 (1.3)	6.0 (1.5)	7.0 (1.8)
Engine Air Flow - ft. <sup>3</sup> /min. (m <sup>3</sup> /min.).....	930 (26)	1120 (32)	1300 (37)	1425 (40)
Maximum Allowable Temperature (Ambient Air To Engine Inlet) - °F (°C).....		30 (17)		

<b>Lubrication System</b>	<b>All Speeds</b>
Oil Pressure - normal - lb./in. <sup>2</sup> (kPa) .....	40-70 (276-433)
In Pan Oil Temperature - °F (°C) .....	190-220 (88-104)
Oil Pan Capacity - High - qt. (L) .....	20 (19)
Low - qt. (L).....	16 (15)
Total Oil Capacity with Filters - qt. (L).....	22 (21)

<b>Performance</b>	<b>1470</b>	<b>1760</b>	<b>2100</b>	<b>2350</b>
BMEP - lb./in. <sup>2</sup> (kPa) .....	154 (1061)	150 (1035)	141 (971)	135 (933)
Piston Speed - ft./min. (m/min.).....	1225 (373)	1467 (447)	1750 (533)	1958 (597)
Noise - dB (A) @ 1m.....	100 (EST)	102 (EST)	104 (EST)	106 (EST)
Power Curve .....		CDDA - 8064 - 01		

\*\*Based On Nominal System. Flow Analysis Must Be Done To Assure Adherence To System Limitations.  
(Minimum Exhaust Pipe Diameter is based on 15 feet of pipe, one elbow, and a silencer  
pressure drop no greater than one half the max. allowable back pressure.)

# DDFP-06FH INSTALLATION & OPERATION DATA

## Basic Engine Description

## All Speeds

Engine Manufacturer .....	Detroit Diesel Corp.
Ignition Type .....	Compression (Diesel)
Number of Cylinders .....	6
Bore and Stroke - in. (mm) .....	4.84 x 5.00 (123 x 127)
Displacement - in. <sup>3</sup> (L) .....	552 (9.1)
Compression Ratio .....	15:1
Combustion System .....	Direct Injection
Engine Type .....	63.5° VEE - 2 Cycle
Aspiration .....	Turbocharged
Firing Order (CW Rotation) .....	1R-1L-3R-3L-2R-2L
Charge Air Cooling Type .....	Jacket Water
Blower Type .....	Roots By-Pass
Blower Drive Ratio .....	1.95:1
Rotation (Viewed from Front)	
Clockwise .....	Standard
Counter-Clockwise .....	Optional
Engine Crankcase Vent System .....	Open
Dimensions and Weight	
Length - in. (mm) (From Drive Flange) .....	45.60 (1158)
Width - in. (mm) .....	41.02 (1042)
Height - in. (mm) (Above Crankshaft Center Line) .....	43.75 (1111)
Weight, Dry - lb. (kg) .....	2217 (1005)
Wet - lb. (kg) .....	2355 (1069)
Installation Drawing .....	D-433

## Cooling System

	1470	1760	2100	2350
Engine H <sub>2</sub> O Heat - Btu/sec. (kJ/sec.) .....	188 (198)	228 (241)	247 (261)	250 (264)
Engine Radiated Heat - Btu/sec. (kJ/sec.) .....		49 (52)		
Heat Exchanger Minimum Flow				
60°F Raw H <sub>2</sub> O - gal./min. (L/min.) .....	14 (53)	23 (87)	28 (106)	29 (110)
95°F Raw H <sub>2</sub> O - gal./min. (L/min.) .....	22 (83)	35 (135)	42 (159)	44 (167)
Heat Exchanger Maximum Cooling H <sub>2</sub> O				
Inlet Pressure - lb./in. <sup>2</sup> (kPa) .....		60 (414)		
Flow - gal./min. (L/min.) .....		70 (265)		
Thermostat, Start to Open - °F (°C) .....		177 (81)		
Fully Open - °F (°C) .....		197 (92)		
Engine Coolant Capacity - qt. (L) .....		42 (40)		
Coolant Pressure Cap - lb./in. <sup>2</sup> (kPa) .....		9 (62)		
Maximum Engine H <sub>2</sub> O Temperature - °F (°C) .....		200 (93)		
Minimum Engine H <sub>2</sub> O Temperature - °F (°C) .....		160 (71)		

## Electric System - DC

## All Speeds

System Voltage (Nominal) .....	24
Battery Capacity for Ambients Above 32°F - CCA @ 0°F .....	900
Voltage (Nominal) .....	12
Qty. per Battery Bank .....	2
SAE size per J537 .....	8D-900
Battery Cable Circuit*, Max Resistance - ohm .....	0.002
Battery Cable Minimum Size	
0-225 in. Circuit* Length .....	No. 00
225-300 in. Circuit* Length .....	No. 000
301-380 in. Circuit* Length .....	No. 0000
Charging Alternator Output - Amp. ....	40
Starter Cranking Amps - @ 40° F .....	595

\*Positive and Negative Cables Combined Length

# DDFP-06FH INSTALLATION & OPERATION DATA (Continued)

## Exhaust System

	<b>1470</b>	<b>1760</b>	<b>2100</b>	<b>2350</b>
Exhaust Flow - ft. <sup>3</sup> /min. (m <sup>3</sup> /min.).....	2537 (72)	2966 (84)	3140 (89)	3177 (90)
Exhaust Temperature - °F (°C).....	752 (400)	768 (409)	791 (422)	779 (415)
Maximum Allowable Back Pressure - in. H <sub>2</sub> O (kPa) .....	19 (4.7)	20 (4.9)	23 (5.7)	25 (6.2)
Minimum Exhaust Pipe Dia. - in. (mm)** Sch. 40 .....	6.0 (154)	6.0 (154)	8.0 (203)	8.0 (203)

## Fuel System

Fuel Pressure - lb./in. <sup>2</sup> (kPa) .....	58 (400)	62 (428)	64 (442)	65 (449)
Fuel Consumption - gal./hr. (L/hr.) .....	19 (72)	23 (87)	25 (95)	26 (98)
Fuel Return Rate - gal./hr. (L/hr.) .....	63 (239)	71 (269)	80 (303)	83 (315)
Total Fuel Flow - gal./hr. (L/hr.).....	82 (310)	94 (356)	105 (397)	109 (413)
Minimum Line Size - Supply - in. (mm)** .....		.75 (19) Sch. 40 - Black		
Return - in. (mm)** .....		.50 (13) Sch. 40 - Black		
Maximum Allowable Fuel Pump Suction Clean System - in. H <sub>2</sub> O (kPa) .....		82 (20)		
Dirty System - in. H <sub>2</sub> O (kPa) .....		164 (40)		
Maximum Allowable Head on Fuel Pump - ft(m) .....		5.0 (1.5)		
Fuel Filter Micron Size - Primary.....		30		
Secondary.....		12		
Fuel Injector/Timing .....		7105/1.508; 145/1.508		
Fuel Modulator/Setting .....		None		

## Heater System

### All Speeds

Jacket Water Heater .....	Standard
Wattage (Nominal) .....	2500
Voltage - VAC, 1P .....	230
Optional Voltage - VAC, 1P .....	115
Lube Oil Heater (Required When Ambient Is Below 50°F (10°C)).....	Optional
Wattage.....	125

## Induction Air System

### **1470      1760      2100      2350**

Air Cleaner Type .....	Indoors Service Only - Washable			
Air Intake Restriction Maximum Limit Dirty Air Cleaner - in. H <sub>2</sub> O (kPa).....	6.5 (1.7)	7.0 (1.8)	8.0 (2.0)	9.0 (2.3)
Clean Air Cleaner - in. H <sub>2</sub> O (kPa) .....	4.5 (1.1)	5.0 (1.3)	6.0 (1.5)	7.0 (1.8)
Engine Air Flow - ft. <sup>3</sup> /min. (m <sup>3</sup> /min.).....	1124 (32)	1297 (37)	1348 (38)	1377 (39)
Maximum Allowable Temperature (Ambient Air To Engine Inlet) - °F (°C).....		30 (17)		

## Lubrication System

### All Speeds

Oil Pressure - normal - lb./in. <sup>2</sup> (kPa) .....	40-70 (276-433)
In Pan Oil Temperature - °F (°C) .....	190-240 (88-116)
Oil Pan Capacity - High - qt. (L) .....	20 (19)
Low - qt. (L).....	16 (15)
Total Oil Capacity with Filters - qt. (L).....	22 (21)

## Performance

### **1470      1760      2100      2350**

BMEP - lb./in. <sup>2</sup> (kPa) .....	171 (1179)	173 (1193)	157 (1083)	142 (979)
Piston Speed - ft./min. (m/min.).....	1225 (373)	1467 (447)	1750 (533)	1958 (597)
Noise - dB (A) @ 1m.....	100 (EST)	102 (EST)	104 (EST)	106 (EST)
Power Curve .....	CDDA - 8064 - 02			

\*\*Based On Nominal System. Flow Analysis Must Be Done To Assure Adherence To System Limitations.  
(Minimum Exhaust Pipe Diameter is based on 15 feet of pipe, one elbow, and a silencer  
pressure drop no greater than one half the max. allowable back pressure.)

# DDFP-08FA INSTALLATION & OPERATION DATA

## **Basic Engine Description**

## **All Speeds**

Engine Manufacturer.....	Detroit Diesel Corp.
Ignition Type .....	Compression (Diesel)
Number of Cylinders .....	8
Bore and Stroke - in. (mm).....	4.84 x 5.00 (123 x 127)
Displacement - in. <sup>3</sup> (L) .....	736 (12.1)
Compression Ratio .....	17:1
Combustion System .....	Direct Injection
Engine Type.....	63.5° VEE - 2 Cycle
Aspiration .....	Turbocharged
Firing Order (CW Rotation) .....	1L-3R-3L-4R-4L-2R-2L-1R
Charge Air Cooling Type .....	Jacket Water
Blower Type .....	Roots By-Pass
Blower Drive Ratio .....	1.95:1
Rotation (Viewed from Front)	
Clockwise .....	Standard
Counter-Clockwise .....	Optional
Engine Crankcase Vent System.....	Open
Dimensions and Weight	
Length - in. (mm) (From Drive Flange).....	51.10 (1298)
Width - in. (mm).....	40.34 (1025)
Height - in. (mm) (Above Crankshaft Center Line) .....	43.75 (1111)
Weight, Dry - lb. (kg) .....	2605 (1182)
Wet - lb. (kg) .....	2793 (1268)
Installation Drawing .....	D-433

## **Cooling System**

	<b>1470</b>	<b>1760</b>	<b>2100</b>	<b>2350</b>
Engine H <sub>2</sub> O Heat - Btu/sec. (kJ/sec.) .....	275 (290)	312 (329)	376 (397)	439 (463)
Engine Radiated Heat - Btu/sec. (kJ/sec.).....		47 (50)		
Heat Exchanger Minimum Flow				
60°F Raw H <sub>2</sub> O - gal./min. (L/min.) .....	40 (151)	48 (182)	56 (212)	64 (242)
95°F Raw H <sub>2</sub> O - gal./min. (L/min.) .....	67 (254)	76 (288)	81 (307)	87 (329)
Heat Exchanger Maximum Cooling H <sub>2</sub> O				
Inlet Pressure - lb./in. <sup>2</sup> (kPa) .....		20 (138)		
Flow - gal./min. (L/min.) .....		110 (416)		
Thermostat, Start to Open - °F (°C) .....		177 (81)		
Fully Open - °F (°C) .....		197 (92)		
Engine Coolant Capacity - qt. (L) .....		59 (53)		
Coolant Pressure Cap - lb./in. <sup>2</sup> (kPa) .....		9 (62)		
Maximum Engine H <sub>2</sub> O Temperature - °F (°C) .....		200 (93)		
Minimum Engine H <sub>2</sub> O Temperature - °F (°C).....		160 (71)		

## **Electric System - DC**

## **All Speeds**

System Voltage (Nominal) .....	24
Battery Capacity for Ambients Above 32°F - CCA @ 0°F .....	900
Voltage (Nominal) .....	12
Qty. per Battery Bank .....	2
SAE size per J537 .....	8D-900
Battery Cable Circuit*, Max Resistance - ohm .....	0.002
Battery Cable Minimum Size	
0-225 in. Circuit* Length .....	No. 00
225-300 in. Circuit* Length .....	No. 000
301-380 in. Circuit* Length .....	No. 0000
Charging Alternator Output - Amp. ....	40
Starter Cranking Amps - @ 40° F .....	668

# DDFP-08FA INSTALLATION & OPERATION DATA (Continued)

<b>Exhaust System</b>	<b>1470</b>	<b>1760</b>	<b>2100</b>	<b>2350</b>
Exhaust Flow - ft. <sup>3</sup> /min. (m <sup>3</sup> /min.) .....	2805 (79)	3193 (90)	3494 (99)	3669 (104)
Exhaust Temperature - °F (°C) .....	785 (418)	775 (413)	765 (407)	760 (404)
Maximum Allowable Back Pressure - in. H <sub>2</sub> O (kPa) .....	19 (4.7)	20 (4.9)	23 (5.7)	25 (6.2)
Minimum Exhaust Pipe Dia. - in. (mm)** .....	Single 8.0 (203) Sch. 40			

<b>Fuel System</b>				
Fuel Pressure - lb./in. <sup>2</sup> (kPa) .....	58 (400)	62 (428)	64 (442)	65 (449)
Fuel Consumption - gal./hr. (L/hr.) .....	21 (80)	25 (95)	29 (110)	31 (117)
Fuel Return Rate - gal./hr. (L/hr.) .....	63 (239)	71 (269)	80 (303)	83 (315)
Total Fuel Flow - gal./hr. (L/hr.) .....	84 (318)	96 (363)	109 (413)	114 (432)
Minimum Line Size - Supply - in. (mm)** .....		.75 (19) Sch. 40 - Black		
return - in. (mm)** .....		.50 (13) Sch. 40 - Black		
Maximum Allowable Fuel Pump Suction				
Clean System - in. H <sub>2</sub> O (kPa) .....		82 (20)		
Dirty System - in. H <sub>2</sub> O (kPa) .....		164 (40)		
Maximum Allowable Head on Fuel Pump - ft(m) .....		5.0 (1.5)		
Fuel Filter Micron Size - Primary .....		30		
Secondary .....		12		
Fuel Injector/Timing .....		9225/1.490		
Fuel Modulator/Setting .....		None		

<b>Heater System</b>	<b>All Speeds</b>
Jacket Water Heater .....	Standard
Wattage (Nominal) .....	2500
Voltage - VAC, 1P .....	230
Optional Voltage - VAC, 1P .....	115
Lube Oil Heater (Required When Ambient Is Below 50°F (10°C)) .....	Optional
Wattage .....	150

<b>Induction Air System</b>	<b>1470</b>	<b>1760</b>	<b>2100</b>	<b>2350</b>
Air Cleaner Type .....	Indoors Service Only - Washable			
Air Intake Restriction Maximum Limit				
Dirty Air Cleaner - in. H <sub>2</sub> O (kPa) .....	9.0 (2.3)	11.0 (2.8)	13.0 (3.3)	14.0 (3.6)
Clean Air Cleaner - in. H <sub>2</sub> O (kPa) .....	7.0 (1.8)	9.0 (2.3)	11.0 (2.8)	12.0 (3.1)
Engine Air Flow - ft. <sup>3</sup> /min. (m <sup>3</sup> /min.) .....	1255 (25)	1440 (27)	1590 (45)	1675 (47)
Maximum Allowable Temperature (Ambient Air To Engine Inlet) - °F (°C) .....		30 (17)		

<b>Lubrication System</b>	<b>All Speeds</b>
Oil Pressure - normal - lb./in. <sup>2</sup> (kPa) .....	40-70 (276-433)
In Pan Oil Temperature - °F (°C) .....	230-245 (110-118)
Oil Pan Capacity - High - qt. (L) .....	23 (22)
Low - qt. (L) .....	17 (16)
Total Oil Capacity with Filters - qt. (L) .....	25 (24)

<b>Performance</b>	<b>1470</b>	<b>1760</b>	<b>2100</b>	<b>2350</b>
BMEP - lb./in. <sup>2</sup> (kPa) .....	154 (1061)	156 (1074)	141 (976)	131 (900)
Piston Speed - ft./min. (m/min.) .....	1225 (373)	1467 (447)	1750 (533)	1958 (597)
Noise - dB (A) @ 1m .....	100 (EST)	102 (EST)	104 (EST)	106 (EST)
Power Curve .....	CDDA - 8084 - 02			

\*\*Based On Nominal System. Flow Analysis Must Be Done To Assure Adherence To System Limitations.  
(Minimum Exhaust Pipe Diameter is based on 15 feet of pipe, one elbow, and a silencer  
pressure drop no greater than one half the max. allowable back pressure.)

# DDFP-L8FA INSTALLATION & OPERATION DATA

## Basic Engine Description

## All Speeds

Engine Manufacturer .....	Detroit Diesel Corp.
Ignition Type .....	Compression (Diesel)
Number of Cylinders .....	8
Bore and Stroke - in. (mm).....	4.84 x 5.00 (123 x 127)
Displacement - in. <sup>3</sup> (L) .....	736 (12.1)
Compression Ratio .....	17:1
Combustion System .....	Direct Injection
Engine Type.....	63.5° VEE - 2 Cycle
Aspiration .....	Turbocharged
Firing Order (CW Rotation) .....	1L-3R-3L-4R-4L-2R-2L-1R
Charge Air Cooling Type .....	Jacket Water
Blower Type .....	Roots By-Pass
Blower Drive Ratio .....	1.95:1
Rotation (Viewed from Front)	
Clockwise .....	Standard
Counter-Clockwise .....	Optional
Engine Crankcase Vent System.....	Open
Dimensions and Weight	
Length - in. (mm) (From Drive Flange).....	51.10 (1298)
Width - in. (mm).....	40.34 (1025)
Height - in. (mm) (Above Crankshaft Center Line) .....	43.75 (1111)
Weight, Dry - lb. (kg) .....	2605 (1182)
Wet - lb. (kg) .....	2793 (1268)
Installation Drawing .....	D-433

## Cooling System

	1470	1760	2100	2350
Engine H <sub>2</sub> O Heat - Btu/sec. (kJ/sec.) .....	249 (263)	283 (299)	340 (359)	397 (419)
Engine Radiated Heat - Btu/sec. (kJ/sec.).....		45 (47)		
Heat Exchanger Minimum Flow				
60°F Raw H <sub>2</sub> O - gal./min. (L/min.) .....	36 (136)	43 (163)	51 (193)	58 (220)
95°F Raw H <sub>2</sub> O - gal./min. (L/min.) .....	61 (231)	69 (261)	73 (276)	79 (299)
Heat Exchanger Maximum Cooling H <sub>2</sub> O				
Inlet Pressure - lb./in. <sup>2</sup> (kPa) .....		60 (44)		
Flow - gal./min. (L/min.) .....		110 (416)		
Thermostat, Start to Open - °F (°C) .....		177 (81)		
Fully Open - °F (°C) .....		197 (92)		
Engine Coolant Capacity - qt. (L) .....		59 (53)		
Coolant Pressure Cap - lb./in. <sup>2</sup> (kPa) .....		9 (62)		
Maximum Engine H <sub>2</sub> O Temperature - °F (°C) .....		200 (93)		
Minimum Engine H <sub>2</sub> O Temperature - °F (°C).....		160 (71)		

## Electric System - DC

## All Speeds

System Voltage (Nominal) .....	24
Battery Capacity for Ambients Above 32°F - CCA @ 0°F .....	900
Voltage (Nominal) .....	12
Qty. per Battery Bank .....	2
SAE size per J537 .....	8D-900
Battery Cable Circuit*, Max Resistance - ohm .....	0.002
Battery Cable Minimum Size	
0-225 in. Circuit* Length .....	No. 00
225-300 in. Circuit* Length .....	No. 000
301-380 in. Circuit* Length .....	No. 0000
Charging Alternator Output - Amp. ....	40
Starter Cranking Amps - @ 40° F .....	668

\*Positive and Negative Cables Combined Length

NOTE: This Engine Is Intended For Indoor Installation Or In A Weatherproof Enclosure.

(Continued)

# DDFP-L8FA INSTALLATION & OPERATION DATA (Continued)

<u>Exhaust System</u>	<b>1470</b>	<b>1760</b>	<b>2100</b>	<b>2350</b>
Exhaust Flow - ft. <sup>3</sup> /min. (m <sup>3</sup> /min.) .....	2584 (73)	2987 (85)	3283 (93)	3461 (98)
Exhaust Temperature - °F (°C) .....	765 (407)	750 (399)	735 (391)	730 (388)
Maximum Allowable Back Pressure - in. H <sub>2</sub> O (kPa) .....	19 (4.7)	26 (6.6)	28 (7.1)	30 (7.6)
Minimum Exhaust Pipe Dia. - in. (mm)** .....	Single 8.0 (203) Sch. 40			

<u>Fuel System</u>				
Fuel Pressure - lb./in. <sup>2</sup> (kPa) .....	58 (400)	62 (428)	64 (442)	65 (449)
Fuel Consumption - gal./hr. (L/hr.) .....	19 (72)	23 (87)	26 (99)	28 (106)
Fuel Return Rate - gal./hr. (L/hr.) .....	63 (239)	71 (269)	80 (303)	83 (315)
Total Fuel Flow - gal./hr. (L/hr.) .....	82 (311)	94 (356)	106 (402)	111 (420)
Minimum Line Size - Supply - in. (mm)** .....	.75 (19) Sch. 40 - Black			
..... Return - in. (mm)** .....	.50 (13) Sch. 40 - Black			
Maximum Allowable Fuel Pump Suction Clean System - in. H <sub>2</sub> O (kPa) .....	82 (20)			
Dirty System - in. H <sub>2</sub> O (kPa) .....	164 (40)			
Maximum Allowable Head on Fuel Pump - ft(m) .....	5.0 (1.5)			
Fuel Filter Micron Size - Primary .....	30			
Secondary .....	12			
Fuel Injector/Timing .....	9225/1.490			
Fuel Modulator/Setting .....	None			

<u>Heater System</u>	<b>All Speeds</b>
Jacket Water Heater .....	Standard
Wattage (Nominal) .....	2500
Voltage - VAC, 1P .....	230
Optional Voltage - VAC, 1P .....	115
Lube Oil Heater (Required When Ambient Is Below 50°F (10°C)) .....	Optional
Wattage .....	150

<u>Induction Air System</u>	<b>1470</b>	<b>1760</b>	<b>2100</b>	<b>2350</b>
Air Cleaner Type .....	Indoors Service Only - Washable			
Air Intake Restriction Maximum Limit Dirty Air Cleaner - in. H <sub>2</sub> O (kPa) .....	9.0 (2.3)	11.0 (2.8)	13.0 (3.3)	14.0 (3.6)
Clean Air Cleaner - in. H <sub>2</sub> O (kPa) .....	7.0 (1.8)	9.0 (2.3)	11.0 (2.8)	12.0 (3.1)
Engine Air Flow - ft. <sup>3</sup> /min. (m <sup>3</sup> /min.) .....	1175 (33)	1375 (39)	1530 (43)	1620 (46)
Maximum Allowable Temperature Rise (Ambient Air To Engine Inlet) - °F (°C) .....	30 (17)			

<u>Lubrication System</u>	<b>All Speeds</b>
Oil Pressure - normal - lb./in. <sup>2</sup> (kPa) .....	40-70 (276-433)
In Pan Oil Temperature - °F (°C) .....	230-245 (110-118)
Oil Pan Capacity - High - qt. (L) .....	23 (22)
Low - qt. (L) .....	17 (16)
Total Oil Capacity with Filters - qt. (L) .....	25 (24)

<u>Performance</u>	<b>1470</b>	<b>1760</b>	<b>2100</b>	<b>2350</b>
BMEP - lb./in. <sup>2</sup> (kPa) .....	139 (960)	141 (970)	128 (884)	120 (813)
Piston Speed - ft./min. (m/min.) .....	1225 (373)	1467 (447)	1750 (533)	1958 (597)
Noise - dB (A) @ 1m .....	99 (EST)	101 (EST)	103 (EST)	105 (EST)
Power Curve .....	CDDA - 8084 - 01			

\*\*Based On Nominal System. Flow Analysis Must Be Done To Assure Adherence To System Limitations.  
(Minimum Exhaust Pipe Diameter is based on 15 feet of pipe, one elbow, and a silencer  
pressure drop no greater than one half the max. allowable back pressure.)

# DDFP-08FH INSTALLATION & OPERATION DATA

## Basic Engine Description

Engine Manufacturer.....	Detroit Diesel Corp.
Ignition Type.....	Compression (Diesel)
Number of Cylinders.....	8
Bore and Stroke - in. (mm).....	4.84 x 5.00 (123 x 127)
Displacement - in. <sup>3</sup> (L).....	736 (12.1)
Compression Ratio.....	17:1
Combustion System.....	Direct Injection
Engine Type.....	63.5° VEE - 2 Cycle
Aspiration.....	Turbocharged
Firing Order (CW Rotation).....	1L-3R-3L-4R-4L-2R-2L-1R
Charge Air Cooling Type.....	Jacket Water
Blower Type.....	Roots By-Pass
Blower Drive Ratio.....	1.95:1
Rotation (Viewed from Front)	
Clockwise.....	Standard
Counter-Clockwise.....	Optional
Engine Crankcase Vent System.....	Open
Dimensions and Weight	
Length - in. (mm) (From Drive Flange).....	51.10 (1298)
Width - in. (mm).....	40.34 (1025)
Height - in. (mm) (Above Crankshaft Center Line).....	43.75 (1111)
Weight, Dry - lb. (kg).....	2605 (1182)
Wet - lb. (kg).....	2793 (1268)
Installation Drawing.....	D-433

## All Speeds

## Cooling System

	<b>1470</b>	<b>1760</b>	<b>2100</b>	<b>2350</b>
Engine H <sub>2</sub> O Heat - Btu/sec. (kJ/sec.).....	296 (312)	317 (334)	371 (391)	396 (418)
Engine Radiated Heat - Btu/sec. (kJ/sec.).....		55 (58)		
Heat Exchanger Minimum Flow				
60°F Raw H <sub>2</sub> O - gal./min. (L/min.).....	39 (148)	42 (159)	48 (182)	52 (197)
95°F Raw H <sub>2</sub> O - gal./min. (L/min.).....	64 (242)	66 (250)	70 (265)	72 (273)
Heat Exchanger Maximum Cooling H <sub>2</sub> O				
Inlet Pressure - lb./in. <sup>2</sup> (kPa).....		20 (138)		
Flow - gal./min. (L/min.).....		110 (416)		
Thermostat, Start to Open - °F (°C).....		177 (81)		
Fully Open - °F (°C).....		197 (92)		
Engine Coolant Capacity - qt. (L).....		63 (57)		
Coolant Pressure Cap - lb./in. <sup>2</sup> (kPa).....		9 (62)		
Maximum Engine H <sub>2</sub> O Temperature - °F (°C).....		200 (93)		
Minimum Engine H <sub>2</sub> O Temperature - °F (°C).....		160 (71)		

## Electric System - DC

	<b>All Speeds</b>
System Voltage (Nominal).....	24
Battery Capacity for Ambients Above 32°F - CCA @ 0°F.....	900
Voltage (Nominal).....	12
Qty. per Battery Bank.....	2
SAE size per J537.....	8D-900
Battery Cable Circuit*, Max Resistance - ohm.....	0.002
Battery Cable Minimum Size	
0-225 in. Circuit* Length.....	No. 00
225-300 in. Circuit* Length.....	No. 000
301-380 in. Circuit* Length.....	No. 0000
Charging Alternator Output - Amp.....	40
Starter Cranking Amps - @ 40° F.....	668

\*Positive and Negative Cables Combined Length

NOTE: This Engine Is Intended For Indoor Installation Or In A Weatherproof Enclosure.

(Continued)



# DDFP-08FH INSTALLATION & OPERATION DATA (Continued)

<b>Exhaust System</b>	<b>1470</b>	<b>1760</b>	<b>2100</b>	<b>2350</b>
Exhaust Flow - ft. <sup>3</sup> /min. (m <sup>3</sup> /min.).....	2805 (79)	3193 (90)	3494 (99)	3669 (104)
Exhaust Temperature - °F (°C).....	785 (418)	775 (413)	765 (407)	760 (404)
Maximum Allowable Back Pressure - in. H <sub>2</sub> O (kPa) .....	19 (4.7)	20 (4.9)	23 (5.7)	25 (6.2)
Minimum Exhaust Pipe Dia. - in. (mm)** .....	Single 8.0 (203) Sch. 40			

<b>Fuel System</b>				
Fuel Pressure - lb./in. <sup>2</sup> (kPa) .....	58 (400)	62 (428)	64 (442)	65 (449)
Fuel Consumption - gal./hr. (L/hr.) .....	21 (80)	25 (95)	29 (110)	31 (117)
Fuel Return Rate - gal./hr. (L/hr.) .....	63 (239)	71 (269)	80 (303)	83 (315)
Total Fuel Flow - gal./hr. (L/hr.) .....	84 (318)	96 (363)	109 (413)	114 (432)
Minimum Line Size - Supply - in. (mm)** .....	.75 (19) Sch. 40 - Black			
..... return - in. (mm)** .....	.50 (13) Sch. 40 - Black			
Maximum Allowable Fuel Pump Suction Clean System - in. H <sub>2</sub> O (kPa) .....	82 (20)			
Dirty System - in. H <sub>2</sub> O (kPa) .....	164 (40)			
Maximum Allowable Head on Fuel Pump - ft(m) .....	5.0 (1.5)			
Fuel Filter Micron Size - Primary.....	30			
Secondary.....	12			
Fuel Injector/Timing .....	9225/1.490			
Fuel Modulator/Setting .....	None			

<b>Heater System</b>	<b>All Speeds</b>
Jacket Water Heater .....	Standard
Wattage (Nominal) .....	2500
Voltage - VAC, 1P .....	230
Optional Voltage - VAC, 1P .....	115
Lube Oil Heater (Required When Ambient Is Below 50°F (10°C)).....	Optional
Wattage.....	150

<b>Induction Air System</b>	<b>1470</b>	<b>1760</b>	<b>2100</b>	<b>2350</b>
Air Cleaner Type .....	Indoors Service Only - Washable			
Air Intake Restriction Maximum Limit				
Dirty Air Cleaner - in. H <sub>2</sub> O (kPa).....	9.0 (2.3)	11.0 (2.8)	13.0 (3.3)	14.0 (3.6)
Clean Air Cleaner - in. H <sub>2</sub> O (kPa) .....	7.0 (1.8)	9.0 (2.3)	11.0 (2.8)	12.0 (3.1)
Engine Air Flow - ft. <sup>3</sup> /min. (m <sup>3</sup> /min.).....	1255 (36)	1440 (41)	1590 (45)	1675 (47)
Maximum Allowable Temperature Rise (Ambient Air To Engine Inlet) - °F (°C).....	30 (17)			

<b>Lubrication System</b>	<b>All Speeds</b>
Oil Pressure - normal - lb./in. <sup>2</sup> (kPa) .....	40-70 (276-433)
In Pan Oil Temperature - °F (°C) .....	230-245 (110-118)
Oil Pan Capacity - High - qt. (L) .....	23 (22)
Low - qt. (L).....	17 (16)
Total Oil Capacity with Filters - qt. (L).....	25 (24)

<b>Performance</b>	<b>1470</b>	<b>1760</b>	<b>2100</b>	<b>2350</b>
BMEP - lb./in. <sup>2</sup> (kPa) .....	154 (1061)	156 (1074)	141 (976)	131 (900)
Piston Speed - ft./min. (m/min.).....	1225 (373)	1467 (447)	1750 (533)	1958 (597)
Noise - dB (A) @ 1m.....	100 (EST)	102 (EST)	104 (EST)	106 (EST)
Power Curve .....	CDDA - 8084 - 02			

\*\*Based On Nominal System. Flow Analysis Must Be Done To Assure Adherence To System Limitations.  
(Minimum Exhaust Pipe Diameter is based on 15 feet of pipe, one elbow, and a silencer  
pressure drop no greater than one half the max. allowable back pressure.)

# DDFP-12FT INSTALLATION & OPERATION DATA

<u>Basic Engine Description</u>	<u>All Speeds</u>
Engine Manufacturer.....	Detroit Diesel Corp.
Ignition Type.....	Compression (Diesel)
Number of Cylinders.....	12
Bore and Stroke - in. (mm).....	4.84 x 5.00 (123 x 127)
Displacement - in. <sup>3</sup> (L).....	1104 (18.1)
Compression Ratio.....	17:1
Combustion System.....	Direct Injection
Engine Type.....	63.5° VEE - 2 Cycle
Aspiration.....	Turbocharged
Firing Order (CW Rotation).....	1L-6L-3R-5R-3L-5L-2R -4R-2L-4L-1L-6R
Charge Air Cooling Type.....	None
Blower Type.....	Roots
Blower Drive Ratio.....	2.0:1
Rotation (Viewed from Front)	
Clockwise.....	Standard
Counter-Clockwise.....	Optional
Engine Crankcase Vent System.....	Open
Dimensions and Weight	
Length - in. (mm) (From Drive Flange).....	73.54 (1868)
Width - in. (mm).....	49.37 (1254)
Height - in. (mm) (Above Crankshaft Center Line).....	43.64 (1108)
Weight, Dry - lb. (kg).....	4734 (2147)
Wet - lb. (kg).....	5087 (2308)
Installation Drawing.....	D-445

<u>Cooling System</u>	<u>1470</u>	<u>1760</u>	<u>2100</u>
Engine H <sub>2</sub> O Heat - Btu/sec. (kJ/sec.).....	264 (279)	308 (325)	331 (349)
Engine Radiated Heat - Btu/sec. (kJ/sec.).....		72(76)	
Heat Exchanger Minimum Flow			
60°F Raw H <sub>2</sub> O - gal./min. (L/min.).....	26 (98)	29 (110)	37 (140)
95°F Raw H <sub>2</sub> O - gal./min. (L/min.).....	41 (155)	45 (170)	58 (220)
Heat Exchanger Maximum Cooling H <sub>2</sub> O			
Inlet Pressure - lb./in. <sup>2</sup> (kPa).....		60 (414)	
Flow - gal./min. (L/min.).....		120 (454)	
Thermostat, Start to Open - °F (°C).....		177 (81)	
Fully Open - °F (°C).....		197 (92)	
Engine Coolant Capacity - qt. (L).....		145 (137)	
Coolant Pressure Cap - lb./in. <sup>2</sup> (kPa).....		9 (62)	
Maximum Engine H <sub>2</sub> O Temperature - °F (°C).....		200 (93)	
Minimum Engine H <sub>2</sub> O Temperature - °F (°C).....		160 (71)	

<u>Electric System - DC</u>	<u>All Speeds</u>
System Voltage (Nominal).....	24
Battery Capacity for Ambients Above 32°F - CCA @ 0°F.....	900
Voltage (Nominal).....	12
Qty. per Battery Bank.....	2
SAE size per J537.....	8D-900
Battery Cable Circuit*, Max Resistance - ohm.....	0.002
Battery Cable Minimum Size	
0-225 in. Circuit* Length.....	No. 00
225-300 in. Circuit* Length.....	No. 000
301-380 in. Circuit* Length.....	No. 0000
Charging Alternator Output - Amp.....	40
Starter Cranking Amps - @ 40° F.....	668

\*Positive and Negative Cables Combined Length

NOTE: This Engine Is Intended For Indoor Installation Or In A Weatherproof Enclosure.

(Continued)

# DDFP-12FT INSTALLATION & OPERATION DATA (Continued)

## Exhaust System

	<b>1470</b>	<b>1760</b>	<b>2100</b>
Exhaust Flow - ft. <sup>3</sup> /min. (m <sup>3</sup> /min.) .....	3939 (112)	5000 (142)	6347 (180)
Exhaust Temperature - °F (°C) .....	805 (429)	782 (416)	783(417)
Maximum Allowable Back Pressure -			
in. H <sub>2</sub> O (kPa) .....	19 (4.7)	20 (4.9)	23 (5.7)
Min. Exhaust Pipe Dia.-in. (mm)** .....	Dual 6.0 (154) Sch. 40		

## Fuel System

Fuel Pressure - lb./in. <sup>2</sup> (kPa) .....	58 (400)	62 (428)	64 (442)
Fuel Consumption - gal./hr. (L/hr.) .....	28 (106)	35 (132)	41 (155)
Fuel Return Rate - gal./hr. (L/hr.) .....	63 (239)	71 (269)	80 (303)
Total Fuel Flow - gal./hr. (L/hr.) .....	91 (345)	106 (401)	121 (458)
Minimum Line Size - Supply - in. (mm)** .....		.75 (19) Sch. 40 - Black	
return - in. (mm)** .....		.50 (13) Sch. 40 - Black	
Maximum Allowable Fuel Pump Suction			
Clean System - in. H <sub>2</sub> O (kPa) .....		82 (20)	
Dirty System - in. H <sub>2</sub> O (kPa) .....		164 (40)	
Maximum Allowable Head on Fuel Pump - ft(m) .....		5.0 (1.5)	
Fuel Filter Micron Size - Primary.....		30	
Secondary.....		12	
Fuel Injector/Timing - in. (mm).....		9215/1.46 (37.084)	
Fuel Modulator/Setting .....		None	

## Heater System

### All Speeds

Jacket Water Heater .....	Standard
Wattage (Nominal) .....	4000
Voltage - VAC, 1P .....	230
Optional Voltage - VAC, 1P .....	460
Lube Oil Heater (Required When Ambient Is Below 50°F (10°C)).....	Optional
Wattage.....	300

## Induction Air System

### 1470      1760      2100

Air Cleaner Type .....	Indoors Service Only - Washable		
Air Intake Restriction Maximum Limit			
Dirty Air Cleaner - in. H <sub>2</sub> O (kPa).....	8.0 (2.0)	11.0 (2.8)	14.0 (3.5)
Clean Air Cleaner - in. H <sub>2</sub> O (kPa) .....	6.0 (1.5)	9.0 (2.3)	12.0 (3.0)
Engine Air Flow - ft. <sup>3</sup> /min. (m <sup>3</sup> /min.).....	1672 (47)	2162 (61)	2742 (78)
Maximum Allowable Temperature Rise (Ambient Air To Engine Inlet) - °F (°C).....		30 (17)	

## Lubrication System

### All Speeds

Oil Pressure - normal - lb./in. <sup>2</sup> (kPa) .....	40-70 (276-433)
In Pan Oil Temperature - °F (°C) .....	230-245 (110-118)
Oil Pan Capacity - High - qt. (L) .....	36 (34)
Low - qt. (L).....	28 (26)
Total Oil Capacity with Filters - qt. (L).....	38 (36)

## Performance

### 1470      1760      2100

BMEP - lb./in. <sup>2</sup> (kPa) .....	134 (924)	135 (931)	120 (827)
Piston Speed - ft./min. (m/min.).....			
Noise - dB (A) @ 1m.....	98.100.2	101.2	102.0
Power Curve .....		CDDA - 8124 - 02	

# DDFP-12FH INSTALLATION & OPERATION DATA

## Basic Engine Description

Engine Manufacturer .....	Detroit Diesel Corp.
Ignition Type .....	Compression (Diesel)
Number of Cylinders .....	12
Bore and Stroke - in. (mm).....	4.84 x 5.00 (123 x 127)
Displacement - in. <sup>3</sup> (L) .....	1104 (18.1)
Compression Ratio .....	15:1
Combustion System .....	Direct Injection
Engine Type.....	63.5° VEE - 2 Cycle
Aspiration .....	Turbocharged
Firing Order (CW Rotation).....	1L-6L-3R-5R-3L-5L-2R -4R-2L-4L-1L-6R
Charge Air Cooling Type .....	Jacket Water
Blower Type .....	Roots By Pass
Blower Drive Ratio .....	2.0:1
Rotation (Viewed from Front)	
Clockwise .....	Standard
Counter-Clockwise .....	Optional
Engine Crankcase Vent System.....	Open
Dimensions and Weight	
Length - in. (mm) (From Drive Flange).....	73.54 (1868)
Width - in. (mm).....	49.37 (1254)
Height - in. (mm) (Above Crankshaft Center Line) .....	43.64 (1108)
Weight, Dry - lb. (kg) .....	4769 (2163)
Wet - lb. (kg) .....	5138 (2330)
Installation Drawing .....	D-445

## Cooling System

	<b>1470</b>	<b>1760</b>	<b>2100</b>	<b>2350</b>
Engine H <sub>2</sub> O Heat - Btu/sec. (kJ/sec.) .....	355 (375)	415 (438)	470 (496)	500 (527)
Engine Radiated Heat - Btu/sec. (kJ/sec.).....		83 (88)		
Heat Exchanger Minimum Flow				
60°F Raw H <sub>2</sub> O - gal./min. (L/min.) .....	32 (121)	36 (136)	46 (174)	56 (21)
95°F Raw H <sub>2</sub> O - gal./min. (L/min.) .....	51 (193)	56 (212)	73 (276)	88 (33)
Heat Exchanger Maximum Cooling H <sub>2</sub> O				
Inlet Pressure - lb./in. <sup>2</sup> (kPa) .....		60 (414)		
Flow - gal./min. (L/min.) .....		120 (454)		
Thermostat, Start to Open - °F (°C) .....		177 (81)		
Fully Open - °F (°C) .....		197 (92)		
Engine Coolant Capacity - qt. (L) .....		145 (137)		
Coolant Pressure Cap - lb./in. <sup>2</sup> (kPa) .....		9 (62)		
Maximum Engine H <sub>2</sub> O Temperature - °F (°C) .....		200 (93)		
Minimum Engine H <sub>2</sub> O Temperature - °F (°C).....		160 (71)		

## Electric System - DC

	<b>All Speeds</b>
System Voltage (Nominal) .....	24
Battery Capacity for Ambients Above 32°F - CCA @ 0°F .....	900
Voltage (Nominal) .....	12
Qty. per Battery Bank .....	2
SAE size per J537 .....	8D-900
Battery Cable Circuit*, Max Resistance - ohm .....	0.002
Battery Cable Minimum Size	
0-225 in. Circuit* Length .....	
225-300 in. Circuit* Length .....	
301-380 in. Circuit* Length .....	No. 0000
Charging Alternator Output - Amp. ....	40
Starter Cranking Amps - @ 40° F .....	668

\*Positive and Negative Cables Combined Length

NOTE: This Engine Is Intended For Indoor Installation Or In A Weatherproof Enclosure.

(Continued)

# DDFP-12FH

## INSTALLATION & OPERATION DATA (Continued)

### Exhaust System

	<u>1470</u>	<u>1760</u>	<u>2100</u>	<u>2350</u>
Exhaust Flow - ft. <sup>3</sup> /min. (m <sup>3</sup> /min.).....	4626 (131)	5380 (152)	5973 (169)	6318 (179)
Exhaust Temperature - °F (°C).....	885 (474)	855 (457)	845 (452)	855 (457)
Maximum Allowable Back Pressure - in. H <sub>2</sub> O (kPa).....	19 (4.7)	20 (4.9)	23 (5.7)	25 (6.2)
Min. Exhaust Pipe Dia.-in. (mm)** - Dual Sch. 40.....	6.0 (154)	6.0 (154)	8.0 (203)	8.0 (203)

### Fuel System

Fuel Pressure - lb./in. <sup>2</sup> (kPa).....	58 (400)	62 (428)	64 (442)	65 (449)
Fuel Consumption - gal./hr. (L/hr.).....	39 (148)	41 (155)	49 (185)	54 (204)
Fuel Return Rate - gal./hr. (L/hr.).....	63 (239)	71 (269)	80 (303)	83 (315)
Total Fuel Flow - gal./hr. (L/hr.).....	102 (386)	112 (424)	129 (488)	137 (519)
Minimum Line Size - Supply - in. (mm)**.....		.75 (19)	Sch. 40 - Black	
Return - in. (mm)**.....		.50 (13)	Sch. 40 - Black	
Maximum Allowable Fuel Pump Suction Clean System - in. H <sub>2</sub> O (kPa).....		82 (20)		
Dirty System - in. H <sub>2</sub> O (kPa).....		164 (40)		
Maximum Allowable Head on Fuel Pump - ft(m).....		5.0 (1.5)		
Fuel Filter Micron Size - Primary.....		30		
Secondary.....		12		
Fuel Injector/Timing - in. (mm).....		145/1.508 (38.303)		
Fuel Modulator/Setting.....		6#/490		

### Heater System

#### All Speeds

Jacket Water Heater.....		Standard		
Wattage (Nominal).....		4000		
Voltage - VAC, 1P.....		230		
Optional Voltage - VAC, 1P.....		460		
Lube Oil Heater (Required When Ambient Is Below 50°F (10°C)).....		Optional		
Wattage.....		300		
	<u>1470</u>	<u>1760</u>	<u>2100</u>	<u>2350</u>

### Induction Air System

Air Cleaner Type.....		Indoors Service Only - Washable			
Air Intake Restriction Maximum Limit					
Dirty Air Cleaner - in. H <sub>2</sub> O (kPa).....	9.0 (2.3)	11.0 (2.8)	13.5 (3.4)	15.0 (3.8)	
Clean Air Cleaner - in. H <sub>2</sub> O (kPa).....	7.0 (1.8)	9.0 (2.3)	11.5 (2.9)	13.0 (3.3)	
Engine Air Flow - ft. <sup>3</sup> /min. (m <sup>3</sup> /min.).....	1847 (52)	2197 (62)	2458 (70)	2580 (73)	
Maximum Allowable Temperature Rise (Ambient Air To Engine Inlet) - °F (°C).....		30 (17)			

### Lubrication System

#### All Speeds

Oil Pressure - normal - lb./in. <sup>2</sup> (kPa).....		40-70 (276-433)			
In Pan Oil Temperature - °F (°C).....		230-245 (110-118)			
Oil Pan Capacity - High - qt. (L).....		36 (34)			
Low - qt. (L).....		28 (26)			
Total Oil Capacity with Filters - qt. (L).....		38 (36)			
	<u>1470</u>	<u>1760</u>	<u>2100</u>	<u>2350</u>	

### Performance

BMEP - lb./in. <sup>2</sup> (kPa).....	173 (1193)	169 (1165)	161 (1110)	153 (1055)	
Piston Speed - ft./min. (m/min.).....					
Noise - dB (A) @ 1m.....	98.9	100.2	101.2	102.0	
Power Curve.....		CDDA - 8124 - 03			

*\*\*Based On Nominal System. Flow Analysis Must Be Done To Assure Adherence To System Limitations.  
(Minimum Exhaust Pipe Diameter is based on 15 feet of pipe, one elbow, and a silencer  
pressure drop no greater than one half the max. allowable back pressure.)*

# DDFP-03DN; -03DT DDFP -L3DT; -T3DT ENGINE MATERIALS & CONSTRUCTION

## **Air Cleaner**

Type .....Indoor Usage Only  
Oiled Fabric Pleats  
Material.....Surgical Cotton  
Aluminum Mesh

## **Camshaft**

Material.....Forged Steel  
Location .....In Block  
Drive .....Gear  
Type of Cam .....Ground

## **Camshaft Bearing - End**

Journal Diameter .....2.18 in. (55.4 mm)  
Length .....1.50 in. (38.1 mm)  
Material.....SAE 799, Steel Back

## **Camshaft Bearing - Intermediate**

Journal Diameter .....2.18 in. (55.4 mm)  
Length .....1.50 in. (38.1 mm)  
Materials.....SAE 799, Steel Back

## **Connecting Rod**

Type .....Forged I Section  
Material.....Forged Steel, SAE 1141

## **Crank Pin Bearings**

Type .....Precision Half Shell  
Number.....1 Pair Per Cylinder  
Journal Diameter .....2.50 in. (63.5 mm)  
Length .....1.31 in. (33.3 mm)  
Projected Area/Bearing .....10.29 in.<sup>2</sup> (6638.7 mm<sup>2</sup>)  
Material.....Steel Backed Copper-Lead

## **Crankshaft**

Material.....Forged Steel SAE 1041  
Heat Treat .....Induction Hardened  
Type of Balance .....Dynamic

## **Cylinder Block**

Type .....One Piece  
Material.....Cast Iron

## **Cylinder Head**

Type .....Slab 4 Valve  
Material.....Cast Iron

CDDA MAR 97 JTW

## **Exhaust Valve**

Type .....Poppet  
Arrangement.....Overhead Valve  
Number/Cylinder.....4  
Operating Mechanism.....Mechanical Rocker Arm  
Type of Lifter .....Roller/Solid  
Valve Spring  
Number/Valve .....1  
Valve Seat Insert  
Material.....Steel Alloy

## **Heat Exchanger**

Type .....Tube & Shell  
Materials  
Tubes & Headers .....90/10 CU/NI  
Shell .....Copper  
Electrode.....Zinc

## **Liners**

Type .....Wet Liner  
Material.....Gray Cast Iron  
Ports  
Type .....Oval  
Number.....18

## **Main Bearings**

Type .....Precision Half Shells  
Journal Diameter .....3.00 in. (76.2 mm)  
Length .....1.18 in. (30.0 mm)  
Projected Area/Bearing .....11.12 in.<sup>2</sup> (7174.2 mm<sup>2</sup>)  
Material.....Steel Backed Copper-Lead

## **Piston**

Type and Material .....Crosshead Malleable Iron  
Cooling .....Oil - Cocktail Shaker

## **Piston Pin Bushing**

Material.....Bronze With SAE 19  
Overlay, Steel Back

## **Piston Rings - Compression**

Type  
Top Ring .....Chrome Faced Rectangular  
Remaining 2 .....Molybdenum Rectangular

## **Piston Rings - Oil**

Type - Upper .....Single Scraper with Expander  
- Lower.....Double Scraper with Expander  
Number per Piston .....2 Sets  
Location .....Bottom of Skirt

## **Piston Pin**

Type .....Crosshead - Polished & Hardened

# DDFP-L6FA; -T6FA; -06FA; -06FH; -L8FA; -08FA; -08FH ENGINE MATERIALS & CONSTRUCTION

## Air Cleaner

Type .....Indoor Usage Only  
Oiled Fabric Pleats  
Material.....Surgical Cotton  
Aluminum Mesh

## Camshaft

Material.....Steel (SAE 1513)  
Location .....In Block, 1 Per Bank  
Drive .....Gear  
Type of Cam .....Ground

## Camshaft Bearing - End

Journal Diameter .....1.50 in. (38.0 mm)  
Length .....2.12 in. (53.8 mm)  
Material.....Steel Backed Bronze

## Camshaft Bearing - Intermediate

Journal Diameter .....1.50 in. (38.0 mm)  
Length .....1.32 in. (33.5 mm)  
Materials.....Aluminum

## Connecting Rod

Type .....Forged I Section  
Material.....Forged Steel, (SAE 1141)

## Crank Pin Bearings

Type .....Precision Half Shell  
Number.....1 Pair Per Cylinder  
Journal Diameter .....3.00 in. (76.2 mm)  
Length .....1.20 in. (30.5 mm)  
Projected Area/Bearing .....3.60 in.<sup>2</sup> (2323 mm<sup>2</sup>)  
Material.....Steel Backed Copper Lead

## Crankshaft

Material.....Steel (SAE 1548)  
Heat Treat .....Induction Hardened  
Type of Balance .....Dynamic

## Cylinder Block

Type .....One Piece  
Material.....Cast Iron

## Cylinder Head

Type .....Slab 4 Valve  
Material.....Cast Iron

CDDA MAR 97 JTW

## Exhaust Valve

Type .....Poppet  
Arrangement.....Overhead Valve  
Number/Cylinder.....4  
Operating Mechanism.....Mechanical Rocker Arm  
Type of Lifter .....Roller  
Valve Spring  
Number/Valve .....1  
Valve Seat Insert  
Material.....GM3544M

## Heat Exchanger

Type .....Tube & Shell  
Materials  
Tubes & Headers .....90/10 CU/NI  
Shell .....Copper  
Electrode.....Zinc

## Liners

Type .....Wet Liner  
Material.....Cast Iron  
Ports  
Type .....Oval  
Number.....18

## Main Bearings

Type .....Precision Half Shells  
Journal Diameter .....4.50 in. (114.3 mm)  
Length .....1.24 in. (31.5 mm)  
Projected Area/Bearing .....5.58 in.<sup>2</sup> (3600 mm<sup>2</sup>)  
Material.....Steel Backed Copper Lead

## Piston

Type and Material .....Crosshead Malleable Iron  
Cooling .....Oil - Cocktail Shaker

## Piston Pin Bushing

Material.....Steel Backed Bronze

## Piston Rings - Compression

Type  
Top Ring .....Chrome Faced Keystone  
Remaining 2 .....Barrel And Chrome Faced

## Piston Rings - Oil

Type .....Double Scraper with Expander  
Number per Piston .....2 Sets  
Location .....Bottom of Skirt

## Piston Pin

Type .....Crosshead - Polished & Hardened

# DDFP-12FT; -12FH ENGINE MATERIALS & CONSTRUCTION

## **Air Cleaner**

Type .....Indoor Usage Only  
   Oiled Fabric Pleats  
 Material.....Surgical Cotton  
   Aluminum Mesh

## **Camshaft**

Material.....Steel (SAE 1513)  
 Location .....In Block, 1 Per Bank  
 Drive .....Gear  
 Type of Cam .....Ground

## **Camshaft Bearing - End**

Journal Diameter .....1.50 in. (38.0 mm)  
 Length .....2.12 in. (53.8 mm)  
 Material.....Steel Backed Bronze

## **Camshaft Bearing - Intermediate**

Journal Diameter .....1.50 in. (38.0 mm)  
 Length .....1.32 in. (33.5 mm)  
 Materials.....Aluminum

## **Connecting Rod**

Type .....Forged I Section  
 Material.....Forged Steel (SAE 1141)

## **Crank Pin Bearings**

Type .....Precision Half Shell  
 Number.....1 Pair Per Cylinder  
 Journal Diameter .....3.00 in. (76.2 mm)  
 Length .....1.20 in. (30.5 mm)  
 Projected Area/Bearing .....3.60 in.<sup>2</sup> (2323 mm<sup>2</sup>)  
 Material.....Steel Backed Copper Lead

## **Crankshaft**

Material.....Steel (SAE 1548)  
 Heat Treat .....Induction Hardened  
 Type of Balance .....Dynamic

## **Cylinder Block**

Type .....Two Piece  
 Material.....Cast Iron

## **Cylinder Head**

Type .....Slab 4 Valve  
 Material.....Cast Iron

## **Exhaust Valve**

Type .....Poppet  
 Arrangement.....Overhead Valve  
 Number/Cylinder.....4  
 Operating Mechanism.....Mechanical Rocker Arm  
 Type of Lifter .....Roller  
 Valve Spring  
   Number/Valve .....1  
 Valve Seat Insert  
   Material.....GM3544M

## **Heat Exchanger**

Type .....Tube & Bundle  
 Materials  
   Tubes & Headers .....70/30 CU/NI  
   Shell .....Cast Iron  
   Electrode.....Zinc

## **Liners**

Type .....Wet Liner  
 Material.....Cast Iron  
 Ports  
   Type .....Oval  
   Number.....18

## **Main Bearings**

Type .....Precision Half Shells  
 Journal Diameter .....4.50 in. (114.3 mm)  
 Length .....1.24 in. (31.5 mm)  
 Projected Area/Bearing .....5.58 in.<sup>2</sup> (3600 mm<sup>2</sup>)  
 Material.....Steel Backed Copper Lead

## **Piston**

Type and Material .....Crosshead Malleable Iron  
 Cooling .....Oil - Cocktail Shaker

## **Piston Pin Bushing**

Material.....Steel Backed Bronze

## **Piston Rings - Compression**

Type  
   Top Ring .....Chrome Faced Keystone  
   Remaining 2 .....Barrel And Chrome Faced

## **Piston Rings - Oil**

Type .....Double Scraper with Expander  
 Number per Piston .....2 Sets  
 Location .....Bottom of Skirt

## **Piston Pin**

Type .....Crosshead - Polished & Hardened



## PARTS INFORMATION

The parts that make up the DDFP diesel driver are provided from two sources. The basic engine is manufactured and assembled at Detroit Diesel Corporation. The basic engine is shipped to Clarke DD-A in Cincinnati for assembly to the NFPA-20 requirements. Any parts required for this product can be obtained by ordering through the authorized D.D.C. Distributor/Dealer in your area.

The basic engine parts ordering data is contained in the "BASIC ENGINE PARTS" section that follows. The special parts to meet NFPA-20 requirements are detailed under the "OPTION PARTS" section provided as a supplement to this manual.

### BASIC ENGINE PARTS

Progress in industry comes at a rapid pace. In order for the engine manufacturer to keep pace with progress, he needs a versatile product for the many models and arrangements of accessories and mounting parts needed to suit a variety of equipment. In addition, engine refinements and improvements are constantly being introduced. All of this dynamic action must be documented so that the equipment can be serviced if and when it's needed. It is fully documented in the manufacturer's plant and in dealer Parts Departments with Master Files and adequate supporting records. But, what about YOU the user of this equipment? You have neither the time nor the inclination to search for specific part

number data. Detroit Diesel's Distributor/Dealer or organization stands ready to meet your needs. When you contact the Distributor/Dealer, provide the following data from the engine data plate at the left front of the engine:

Model Number \_\_\_\_\_

Serial Number \_\_\_\_\_

Specific Type Number as Listed on the  
Engine Option Plate \_\_\_\_\_

### Other Useful Information:

To help identify basic engine items that may require periodic service, replacement or repair, the following parts are identified.

ITEM	USEAGE	ENGINE(S)	MFG	P/N
Fuel Filter	Primary	I-53	AC	TP936
Fuel Filter	Secondary	I-53	AC	TP928
Fuel Filter	Primary	I-71, V-71 & V-92	AC	TP915D
Fuel Filter	Secondary	I-71, V-71 & V-92	AC	TP916D
Fuel Filter	Primary	12V 92 Only	AC	TP958D
Fuel Filter	Secondary	12V 92 Only	AC	TP959D
Oil Filter		I-53	AC	PF947
Oil Filter		I-71, V-71 & V-92	AC	PF911L

## STANDARD OPTION PARTS

At Clarke DD-A the following "OPTION PARTS" are added to the basic Detroit Diesel engine:

- Engine Heaters and AC Junction Box
- Speed Switch
- Battery Isolator
- Air Cleaner System
- Heat Exchanger System
- Exhaust Blanket Insulation/Guard
- Lube Oil Heater (Optional Material)
- Governor Controls
- FM/UL/ULC Nameplate
- Wiring Harness
- Manual Contactors
- Instrument Panel & Gauges
- DC Junction Box

## STANDARD OPTION PARTS (CONTINUED)

Specific replacement parts for your engine can be ordered through the authorized D.D.C. Distributor/Dealer. When ordering "OPTION PARTS", provide Distributor/Dealer with the following data from the FM/UL/ULC Nameplate:

A. Engine Model No.

\_\_\_\_\_

B. Engine Serial No. \_\_\_\_\_

C. Mfg. Date \_\_\_\_\_

And Part Number from the "Optional Parts Supplement".

\_\_\_\_\_

The authorized DDC Distribution/Dealer will obtain the replacement option parts through Clark e DD A, Cincinnati, Ohio.

### Air Filter

Cleanable Type Use K&N Cleaning Agent P/N 99-0621  
Plus Re-oil Element With K&N 99-0516 Oil Before Use.  
Do Not Use Element Dry.

**NOTE:** SOME ENGINES REQUIRE TWO OIL FILTERS

## ANALYSIS PROGRAM

Analysis Kits are currently available through your local DDC Distributor. These kits can be purchased for a nominal fee to give each DDFP user the capability of taking oil or coolant samples and mailing them to a testing laboratory. By a series of laboratory test they can determine operating conditions that may be harmful to your engine. Sample results are mailed to the sender provided they have completed the sample processing form with the current address. Each kit contains sampling instructions and engine identification

request. For the purpose of laboratory uniformity, please use the DDC model and Serial number as found on the valve rocker cover.

Results will include warnings and recommendations should a problem be found.

Coolant Analysis Kit P/N 23508774

Oil Analysis Kit P/N 12345678

## OWNER ASSISTANCE

The satisfaction and goodwill of the owners of DDFP diesel engines is of primary concern to the DDFP organization including their Distributors/Dealers.

As an owner/operator of a DDFP diesel engine, you have a complete network of Distributor locations plus their dealers in the United States, Canada and worldwide. Consult your "Yellow Page" telephone directory under ENGINES-DIESEL for the authorized agent serving your area. The Distributor/Dealer organization provide:

- Field service by trained personnel
- Emergency service 24 hours per day
- Complete parts support
- Sales assistance for your power needs
- Product information and literature

We recognize, however, that despite the best intentions of everyone concerned, misunderstandings may occur. Normally, any such situation that arises in connection with the sale, operation or service of your engine will be handled by the Distributor/Dealer in your area.

To further assure your complete satisfaction the following procedure should be followed in the event you have a problem that has not been handled satisfactorily.

*Step 1* - Discuss your problem with a member of management from the distributorship or dealership in your area. Frequently, complaints are the result of a breakdown in communication and can quickly be resolved by a member of management. If you have already discussed the problem with the Sales or Service Manager, contact the General Manager. If your problem originates with a dealer, explain the matter to a management member of the distributorship with whom the dealer has his service agreement.

*Step 2* - When it appears that your problem cannot be resolved at the Distributor level without additional assistance, contact:

Clarke Detroit Diesel-Allison  
3133 E. Kemper Road  
Cincinnati, OH 45241

Attention: Fire Pump Service Manager

Phone: 513-771-2200 Ext. 427

Fax: 513-771-5375

Prior to this call, have the following information available:

- Name and location of Distributor/Dealer contacted
- Pump OEM equipment: Model and Rating
- Engine Model and S/N
- Engine delivery date and hours of operation
- Nature of problem
- Chronological summary of units history

*Step 3* - If the problem is still not resolved to your satisfaction, present the entire matter in writing or by phone to the factory:

**Director,  
Reliability and Materials Engr.**  
Detroit Diesel Corporation  
13400 Outer Drive, West  
Detroit, Michigan 48239-4001  
Phone: (313) 592-7357

If the additional review by the DDC factory of all the facts involved indicates that some further action can be taken, the modification center and/or the Distribution/Dealer will be so instructed.

When contacting Clarke DD-A, please keep in mind that ultimately your problem will likely be resolved at the Distributorship/Dealership utilizing their facilities, equipment and personnel. Therefore, it is suggested that you follow the above steps in sequence when requiring assistance.

Should communications be necessary to NFA Headquarters, they can be contacted at:

National Fire Protection Association  
1 Batterymarch Park  
PO Box 9101  
Quincy MA 02269-9101

Codes and Standards  
617-770-3000

**Eastern Region**

187 Monmouth Park Hwy.  
West Long Branch, New Jersey 07704  
Phone: (908) 222-1888

**Southeastern Region**

5111 Bowden Rd.  
Jacksonville, Florida 32216  
Phone: (904) 448-8833

**Central Region**

13400 Outer Drive, West  
Detroit, Michigan 48239-4001  
Phone: (313) 592-5420

**Southwestern Region**

2711 LBJ Freeway, Suite 1036  
Dallas, Texas 75234  
Phone: (214) 247-4313

**Western Region**

10645 Studebaker Road  
Downey, California 90241  
Phone: (213) 929-7016

**Canadian Region**

150 Dufferin Ave.  
Suite 701  
London, Ontario N6A 5N6, Canada  
Phone: (519) 661-0149

**Asia**

7 Jurong Pier Rd.  
Jurong Town, 2262, Singapore  
Phone: (65) 265-5222

**Pacific Region**

13 Lynette Ave.  
Beaumaris, Victoria, 3193 Australia  
Phone: 61-3-589-5181 54/POST FACH

**Europe, Middle East, Africa Region**

Schaftenholzweg  
CH-2557 Studen  
Switzerland  
Phone: 41-32-215-629

**Latin American Region**

2277 N.W. 14th St.  
Latin American Bldg.  
Miami, Florida 33125-0068  
Phone: (305) 637-1555

*Identify the U.S. regional area from the map below:*

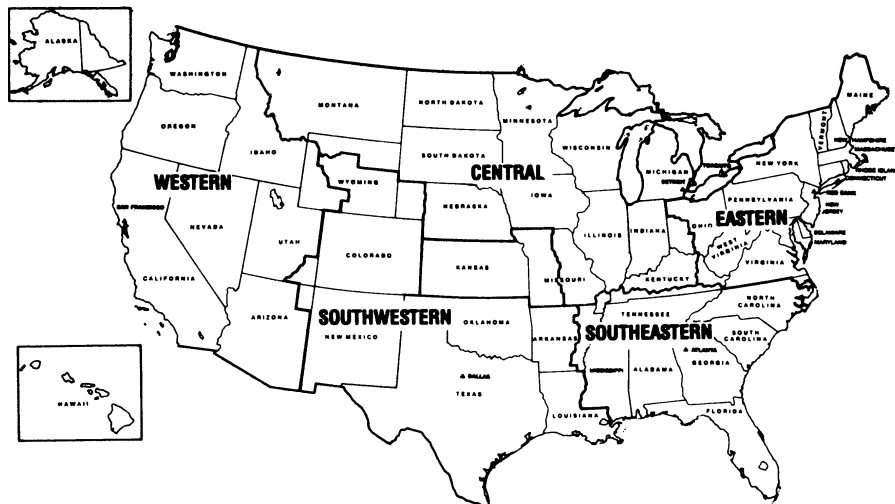

# Warranty On New Detroit Diesel

## Series 53, 71, 92 and 149 Engines

### Used In Stand-by Pump Applications



#### Terms of Coverage: Uses

This warranty applies to the first retail purchaser and subsequent owners during the WARRANTY PERIOD of new Detroit Diesel Series 53, 71, 92 and 149 Engines (referred to as Engine) and attached air compressor, starting motor, alternator and hydraulic pump (referred to as Accessories) manufactured or supplied by Detroit Diesel Corporation\* (referred to as DDC) which are used in stand-by pump applications operated in the United States or Canada and delivered on or after May 1, 1992.

#### Defects

This warranty covers Engine REPAIRS to correct any malfunction occurring during the WARRANTY PERIOD resulting from defects in material or workmanship.

#### Repairs

To obtain warranty repairs, you must request the needed repairs within the WARRANTY PERIOD from an authorized DDC service outlet. Only new genuine parts or remanufactured parts or components supplied or approved by DDC will be used. DDC may, at its discretion, replace rather than repair components. A reasonable time must be allowed to perform the warranty repair. Repairs will be performed during normal business hours. The owner is responsible for the percentage of repair costs shown under WARRANTY PERIOD.

#### Warranty Period

The WARRANTY PERIOD begins on the date the Engine is delivered to the first retail purchaser or put in use prior to sale at retail, whichever date occurs first, and ends at the time limits shown below:

WARRANTY PERIOD				
Item	Warranty Limitations (Whichever Occurs First)		Repair Charge To Be Paid By The Owner	
	MONTHS	ENGINE HOURS	PARTS	LABOR
Engine	0-24	0-1,500	No Charge	No Charge
	25-60	0-1,500	No Charge	100% of service outlet's normal charge
Accessories	0-12	0-1,500	No Charge	No Charge

#### Service Supplies

The cost of service supplies such as coolant, oil and filters which are not reusable due to needed repairs is covered by this warranty.

#### Like Replacement Engine

Engine(s) supplied by DDC as a replacement for an Engine still under warranty will assume the identity of the Engine being replaced and be entitled to the remaining warranty coverage.

#### Mechanic's Travel Expenses

DDC will pay reasonable travel expenses for the repairing mechanic to travel to and from the repair site.

\*In Canada, the reference is to Detroit Diesel or Canada Limited.

#### This Warranty Does Not Cover: Repairs Due To Accidents, Misuse, Storage Damage, Negligence Or Certain Modifications

Repairs due to an accident, misuse, misapplication, storage damage, negligence or modification exceeding DDC specifications, are not covered by this warranty.

#### Engine Removal And Reinstallation

Labor and material costs for engine removal and reinstallation, when necessary to make a warranty repair, are not covered by this warranty.

#### Non-DDC Supplied/Manufactured Components

DDC is not responsible for repair of components and/or assemblies which are manufactured or supplied by another manufacturer, such as power take-offs, intake and exhaust systems. Such items are covered by the equipment manufacturer.

#### Maintenance

DDC is not responsible for the cost of maintenance or repairs due to lack of performance of required maintenance services or the failure to use fuel, oil, lubricants and coolant meeting DDC-recommended specifications. Performance of required maintenance and use of proper fuel, oil, lubricants and coolant are the responsibility of the owner. See the Operator's Guide for full details.

#### Incidental or Consequential Damages

DDC is not responsible for incidental or consequential costs or expenses which the owner may incur as a result of a malfunction or failure covered by this warranty, such as communication expenses, meals, lodging, overtime, towing, loss of use of the Engine or equipment, loss of time, inconvenience, cargo loss or damage, and other similar costs and expenses.

#### Other Limitations

The performance of REPAIRS is the exclusive Owner's remedy under this warranty. DDC does not authorize any person to assume or create for it any other obligation or liability in connection with the Engine or the Accessories.

THIS WARRANTY IS THE ONLY WARRANTY APPLICABLE TO THE ENGINE AND ACCESSORIES AS USED IN STAND-BY PUMP APPLICATIONS. DETROIT DIESEL CORPORATION MAKES NO OTHER WARRANTIES EXPRESS OR IMPLIED, INCLUDING ANY IMPLIED WARRANTY OF MERCHANTABILITY OR FITNESS FOR A PARTICULAR PURPOSE. DETROIT DIESEL CORPORATION SHALL NOT BE LIABLE FOR ANY INCIDENTAL OR CONSEQUENTIAL DAMAGES AS DESCRIBED ABOVE.

**DETROIT DIESEL**®  
CORPORATION



13400 Outer Drive, West / Detroit, Michigan 48239-4001

Telephone: 313-592-5000

Telex: 4320091 / TWX: 810-221-1649

## Warranty on New Perkins Engines

### 1. Products Covered

This warranty applies to Prima, 500 Series, 700 Series, 900 Series, 3.152 family, 4.41, 4.236 family, 6.354 family, 1000 Series, Phaser, 1300 Series, Peregrine, 100 Series, 200 Series, 2000 Series, 3000 Series Diesel and Spark Ignited Engines.

### 2. Duration

The duration of this warranty shall be for a period of 12 months from delivery of any new engine to the first user or for a period of 24 months from the date of dispatch of the engine from Perkins, whichever period expires first. In addition, the following major components will be covered for a further 12 months: cylinder block, casting, cylinder head casting, crankshaft (excluding bearings), camshaft and connecting rods.

### 3. Scope of Warranty

Perkins will, by repair or (at its option) replacement, remedy any failure of such engine which is due to a defect in the workmanship or materials thereof and will accept responsibility for labor and material costs which apply when effecting such remedy. Repair time will be as per Perkins Repair Time schedule or as agreed in cases of application difficulty. Parts and labor rates will be as agreed with Perkins. All repairs must be carried out by an authorized outlet.

Engine(s) or components supplied as replacements for engines under warranty will assume the identity of the engine or part being replaced and be entitled to the remaining warranty coverage. Any engine or component replaced by Perkins shall be disposed of in accordance with Perkins directions.

The warranty extends to the costs of engine removal and reinstallation where appropriate and necessary subject to a maximum of 15 hours labor for industrial, generating set and vehicle applications and a maximum of 18 hours for marine applications.

For 100 Series Engines, the maximum time allowed for removal and refit is 7 hours and 12 hours for 200 Series Engines.

### 4. Proprietary Equipment Fitted by Perkins

All proprietary equipment sourced and fitted by Perkins prior to dispatch of the engine is covered by this warranty except that:

Fuel injection equipment will be serviced and guaranteed through the Fuel Injection Suppliers Service or organization who will carry out 'free of charge' any agreed warranty repair.

Electrical equipment fitted by Perkins will be serviced and guaranteed by the Electrical Suppliers Service or organization who will carry out 'free of charge' any agreed warranty repair.

Labor charges to remove and refit such equipment will be paid by Perkins as per normal warranty procedures in line with the repair time schedule.

### 5. Low Usage Warranty

In cases where the total use of the engine is restricted to 250 hours or less within 12 months from the date of sale to the first user, the warranty will be extended to the second year of operation, providing that the combined total use does not exceed 500 hours. Low usage extended warranty does not apply to 100 Series or 200 Series engines.

viding that the combined total use does not exceed 500 hours. Low usage extended warranty does not apply to 100 Series or 200 Series engines.

### 6. Long Storage

The standard warranty allows for a maximum of 12 months storage before sale. Long storage is not encouraged but at the same time Perkins realize that there will be occasions when the engine has not been sold. Validation Procedures and warranty limitations are available from a Perkins Distributor.

### 7. Limitations and Exclusions

Perkins shall not be liable under this warranty for:

- a. Any accessories or proprietary equipment not fitted by Perkins.
- b. Any engine used without the prior written approval of Perkins for a purpose for which it was not designed.
- c. Any engine or part which is in the opinion of Perkins has been altered, used, maintained, serviced or stored otherwise than in accordance with the Company's recommendations as published.
- d. Any engine or part from which the Perkins number or markings have been removed or altered.
- e. The costs of normal maintenance or regular servicing of the engine.
- f. Expenses such as towing, carriage, subsistence, overtime premiums, owners own labor charges, hire of special equipment.
- g. Component parts considered by Perkins to be consumable items as identified in the applicable users handbook except where replacement is necessary consequent to the nature of the failure and at a time when the owner could not reasonably be expected to pay for these items.
- h. Gradual reduction in operating performance commensurate with the age, kilometers covered or operating hours, including but not limited to, gradual loss of engine compression or gradual increase in oil consumption due to normal operating functions.
- i. Any failure to meet its obligations hereunder which are due to circumstances beyond its reasonable control including but not limited to industrial disputes, fire, severe weather conditions, government decisions, materials shortage, power or machinery breakdown or failure or war.
- j. Any claims made more than 60 days from the date of alleged failure. Perkins obligations under this warranty are limited to the proper costs incurred by its authorized agents of repair or replacement as set out herein.
- k. Perkins shall not be liable whether in contract or tort for any other loss, damage or expense, whether direct, indirect or consequential and whether suffered by the owner or any third party and any other warranties expressed or implied, statutory or otherwise are expressly excluded to the extent that the same may be lawfully so excluded.

## STORAGE

Storing engines requires special attention. Clarke DDFP engines, as prepared for shipment, may be stored for a maximum of six months. During this period, they should be stored indoors in a dry environment. Protective coverings are recommended provided they are arranged to allow for air circulation. The stored engine should be inspected periodically for obvious conditions such as standing water, part theft, excess dirt buildup or any other condition that may be

detrimental to the engine or components. Any such conditions found must be corrected immediately.

If a situation arises that extended storage is unavoidable (beyond six months), it may be necessary to contact your local DDC Distributor/Dealer for assistance. Do not store engines beyond this time without proper protection.

## ALPHABETICAL INDEX

Subject	Page	Subject	Page
<b>A</b>		<b>F</b>	
Adjustments:		Filters:	
Alternator, Water Pump Belts .....	36	Fuel .....	13,44
Air Cleaner .....	16	Lubricating Oil .....	22
Alarm System .....	35	Air Cleaner .....	16
Assistance, Owner .....	46	Firing Order .....	7
Air Box Drains .....	18	Fuel Specifications .....	13
Air Intake System .....	16	Fuel System Operation .....	12
<b>B</b>		Check Valve .....	12
Battery Cables .....	43	Injector .....	12
Battery Recommendations .....	43	Pump .....	12
Battery Charging Alternator .....	36	System Schematic .....	14
<b>C</b>		Maintenance & Service .....	15
Coolant Recommendations .....	26	<b>G</b>	
Cooling System .....	25	General Description .....	2
Anti-Freeze Solutions .....	26	General Specifications .....	6
Cooling System Capacity .....	43	Governor, Engine .....	14,42
Cooling System Components .....	25	Governor Speed Adjustment .....	42
Filling Procedure .....	27	Governor Solenoid .....	33
Heat Exchanger .....	25	Governor Solenoid Adjustment .....	42A-B
Operation .....	25	<b>H</b>	
Maintenance .....	30	Heaters, Engine .....	28,31
Raw Water Cooling Loop .....	29	Hourmeter .....	33
Contactors, Manual .....	36	<b>I</b>	
Cylinder Designation .....	7	Identification Tag (FM/UL/ULC) .....	5
Crankcase Ventilation .....	18	Injector .....	12
<b>D</b>		Instruments .....	33
Description, General .....	2	Installation Data .....	43
Diesel Principle .....	1	<b>J</b>	
Dipstick, Oil Level .....	20	Junction Box (DC) .....	31
<b>E</b>		<b>L</b>	
Electronic Speed Swith .....	10	Lubricating Oil Volume .....	43
Engine Equipment .....	4	Lubricating System .....	20
Engine Heater .....	28,31	Lube Oil Recommendations .....	22
Engine Models .....	43	<b>M</b>	
Engine Out of Fuel .....	15	Maintenance Procedures .....	35
Engine Protective Systems (overspeed) .....	10	Maintenance Schedule .....	11
Engine Rotation .....	7	Manual Contactors .....	36
Engine Start-Up .....	8	Manual Operation .....	33
Engine Tune-Up .....	42	Materials of Construction .....	43-Z
Electrical System .....	31	Model Number Identification .....	2
Exhaust Gas: Temp. & Volume .....	43	Magnetic Pickup .....	33
Exhaust Operation .....	19		



## ALPHABETICAL INDEX (CONTINUED)

Subject	Page	Subject	Page
<b>N</b>			
Name Plate (FM-UL-ULC) .....	5	Specifications:	
Name Plate (Engine) .....	5	Fuel .....	13
<b>O</b>			
Oil Cooler .....	20	General .....	6
Oil Filter .....	22	Lubrication Oil .....	22
Oil Pressure .....	43	Speed Adjustment .....	42
Oil Specifications/Recommendations .....	22	Speed Switch .....	10,33
Operating Instructions .....	8,33	Starting System, Electric .....	34
Option Plate, Engine .....	5	Solenoid, Governor .....	33
Overspeed Reset .....	10	Storage, Extended .....	49
Owner Assistance .....	46	<b>T</b>	
Operation Data .....	43	Tachometer .....	33
Out Of Fuel Procedures .....	15	Thermostat .....	28
Oil Level Dipstick .....	20	Tune-Up Procedures .....	42
<b>P</b>			
Parts Information .....	44	Technical Data .....	43
Preventive Maintenance Schedule .....	11	Two Cycle Principle .....	1
Principles of Operation .....	1	<b>U</b>	
Pump:		Underwriters Labs Nameplate .....	5
Water (Coolant) .....	25	<b>V</b>	
Fuel .....	12	Voltmeter .....	33
Lube Oil .....	20	<b>W</b>	
<b>R</b>			
Raw Water Cooling Loop .....	29	Water Temperature .....	43
Raw Water Flow Requirements .....	43	Wiring Diagram:	
Rotation .....	3	DC System .....	37,38
<b>S</b>			
Standard Model Views .....	9	AC Heater Systems .....	39
Serial Number .....	5	Warranty on Engine .....	48
Service Assistance .....	46	Warranty on Optional Equipment and NFPA-20 Trim Material .....	48
Shutdown Systems .....	33	<b>Z</b>	
<b>Z</b>			
		Zinc Electrode .....	30

# CLARKE FIRE PUMP DRIVERS

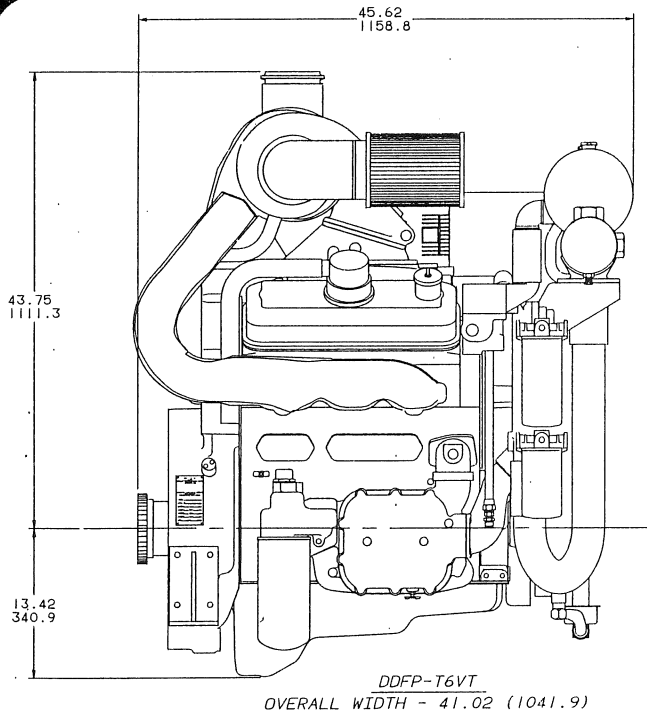

## MODELS

DDFP-L6VT

DDFP-T6VT

### APPROVED RATINGS (BHP\*) FM-UL-ULC

MODEL	SPEED (RPM)				
	1470	1760	1900	2100	2350
DDFP-L6VT	218	265	286	305	310
DDFP-T6VT	254	302	321	341	348

\*Engines are rated at standard SAE conditions of 29.61 in. (752.1 mm) Hg barometer and 77°F (25°C) inlet air temperature [approximates 300 ft. (91.4 m) above sea level] by the testing laboratory (see SAE Standard J 1349).

A deduction of 3 percent from engine horsepower rating at standard SAE conditions shall be made for diesel engines for each 1000 ft. (305 m) altitude above 300 ft. (91.4 m).

A deduction of 1 percent from engine horsepower rating as corrected to standard SAE conditions shall be made for diesel engines for every 10°F (5.6°C) above 77°F (25°C) ambient temperature.

## STANDARD EQUIPMENT

**Air Cleaner** — Direct Mounted, Washable, For Indoor Service Only

**Alternator** — Integral Regulator, 24VDC, 40 Ampere, with Belt Guard

**Exhaust Blankets** — For Manifolds & Turbo Charger

**Flywheel Housing** — SAE #1

**Fuel Check Valve** — Per NFPA-20

**Fuel Pump** — Gear Driven, Gear Type

**Fuel Filters** — Primary & Secondary

**Engine Heater** — 120/208/240 Voltage (AC), 2500 Watts With Thermostat

**Governor** — Mechanical 10%

**Heat Exchanger** — NPTF Connections

**Instrument Panel** — English & Metric, Tachometer, Hourmeter, Water Temperature, Oil Pressure, Voltmeter

**Junction Box** — For Customer Wiring (DC) To Match NFPA Controller

**Lube Oil Cooler** — Engine Water Cooled, Plate Type

**Lube Oil Filter** — Full Flow W/By-Pass Valve

**Lube Pump** — Gear Driven, Gear Type

**Manual Start Controls** — Per NFPA-20

**Power Take Off** — Includes Engine Half of Falk 1080T10 Coupling. Stub Shaft Optional.

**Run-Stop Control** — On Instrument Panel

**Overspeed Control** — Electronic w/Reset

**Starter 24 VDC** — High Torque, Prewired To Manual Contactors

**Throttle Control** — Tamper Proof

**Water Pump** — Gear Driven, Centrifugal Type

meets  
NFPA-20  
Requirements



## SPECIFICATIONS

	DDFP-L6VT	DDFP-T6VT
DDC Engine Series .....	V-71	V-71
No. Cylinders .....	6	6
Aspiration .....	T	T
Rotation** .....	CW STD. CCW AVAILABLE	
Displacement (cu. in.) .....	426	426
Net Wt. (lbs.) .....	2312	2312
Bore (in.) .....	4.25	4.25
Stroke (in.) .....	5.0	5.0
Compression Ratio .....	17:1	17:1
Installation Drawing .....	D-433	D-433

DDC - DETROIT DIESEL CORP.

T - TURBOCHARGED

V-71 UNITS ARE 2 STROKE CYCLE

\*\*VIEWED FROM FRONT

## DESIGN FEATURES

- Direct Mounted Drive Coupling Hub
- Direct Attachment Of Driveshaft Available For Vertical Turbine Drives
- 24 Volt DC Starting System
- Multi-Voltage Heaters (120, 208, 240 VAC)
- Compact Size
- High Horsepower To Weight Ratio
- Direct Injection
- Individual Cylinder Fuel Unit Injectors
- Roller Camshaft Lifters
- Replaceable Cylinder Liners
- Crosshead Pistons To Eliminate Side Load Wear



**CLARKE**

**DETROIT DIESEL-ALLISON**



3133 EAST KEMPER ROAD  
CINCINNATI, OH 45241

## DDFP-L6VT INSTALLATION & OPERATION DATA (Continued)

<b>Exhaust System</b>					
Exhaust Flow - ft. <sup>3</sup> /min. (m <sup>3</sup> /min.) .....	1470	1760	1900	2100	2350
Exhaust Temperature - °F (°C) .....	1619 (46)	1939 (55)	2031 (57)	2191 (62)	2318 (66)
Maximum Allowable Back Pressure -					
in. H <sub>2</sub> O (kPa) .....	19 (4.7)	24 (6.1)	26 (6.6)	29 (7.4)	33 (8.4)
Min. Exhaust Pipe Dia.-in. (mm)** .....			Single 5.0 (127)	Sch. 40	
<b>Fuel System</b>					
Fuel Pressure - lb./in. <sup>2</sup> (kPa) .....	58 (400)	62 (428)	63 (435)	64 (442)	65 (449)
Fuel Consumption - gal./hr. (L/hr.) .....	11 (42)	13 (49)	15 (57)	16 (61)	17 (64)
Fuel Return Rate - gal./hr. (L/hr.) .....	63 (239)	71 (269)	74 (280)	80 (303)	83 (315)
Total Fuel Flow - gal./hr. (L/hr.) .....	74 (280)	84 (318)	89 (337)	96 (363)	100 (379)
Minimum Line Size - Supply - in. (mm)** .....			.75 (19)	Sch. 40 - Black	
Return - in. (mm)** .....			.50 (13)	Sch. 40 - Black	
Maximum Allowable Fuel Pump Suction					
Clean System - in. H <sub>2</sub> O (kPa) .....			82 (20)		
Dirty System - in. H <sub>2</sub> O (kPa) .....			164 (40)		
Fuel Filter Micron Size - Primary .....			30		
Secondary .....			12		
Fuel Injector/Timing - in. (mm) .....			/1.508 (38.303)		
Fuel Modulator/Setting .....			None		
<b>Heater System</b>			<b>All Speeds</b>		
Jacket Water Heater .....			Standard		
Wattage (Nominal) .....			2500		
Voltage, Reconnectable - VAC, 1P .....			120/208/240		
Other Voltages .....			Optional		
Lube Oil Heater (Required When Ambient Is Below 50°F (10°C)) .....			Optional		
Wattage .....			125		
<b>Induction Air System</b>					
Air Cleaner Type .....	1470	1760	1900	2100	2350
Air Intake Restriction Maximum Limit			Indoors Service Only - Washable		
Dirty Air Cleaner - in. H <sub>2</sub> O (kPa) .....	9.0 (2.2)	10.5 (2.6)	11.5 (2.9)	13.5 (3.4)	15.0 (3.7)
Clean Air Cleaner - in. H <sub>2</sub> O (kPa) .....	7.0 (1.7)	8.5 (2.1)	9.5 (2.4)	11.5 (2.9)	13.0 (3.2)
Engine Air Flow - ft. <sup>3</sup> /min. (m <sup>3</sup> /min.) .....	760 (21.5)	877 (24.8)	912 (25.8)	979 (27.7)	1045 (29.6)
<b>Lubrication System</b>					
Oil Pressure - normal - lb./in. <sup>2</sup> (kPa) .....			<b>All Speeds</b>		
In Pan Oil Temperature - °F (°C) .....			40-70 (276-433)		
Oil Pan Capacity - High - qt. (L) .....			220-240 (88-116)		
Low - qt. (L) .....			20 (19)		
Total Oil Capacity with Filters - qt. (L) .....			16 (15)		
			22 (21)		
<b>Performance</b>					
BMEP - lb./in. <sup>2</sup> (kPa) .....	1470	1760	1900	2100	2350
Piston Speed - ft./min. (m/min.) .....	138 (951)	140 (965)	140 (965)	135 (930)	123 (848)
Noise - dB (A) @ 1m .....	1225 (373)	1467 (447)	1583 (483)	1750 (583)	1958 (597)
Power Curve .....			CDDA - 7064 - 01		

\*\*Based On Nominal System. Flow Analysis Must Be Done To Assure Adherence To System Limitations.  
(Minimum Exhaust Pipe Diameter is based on 15 feet of pipe, one elbow, and a silencer  
pressure drop no greater than one half the max. allowable back pressure.)



**CLARKE**  
**DETROIT DIESEL-ALLISON**

3133 EAST KEMPER ROAD  
CINCINNATI, OH 45241



**DDFP-L6VT**  
**INSTALLATION &**  
**OPERATION DATA**

**Basic Engine Description**

Engine Manufacturer .....	<b>All Speeds</b> Detroit Diesel Corp.
Ignition Type .....	Compression (Diesel)
Number of Cylinders .....	6
Bore and Stroke - in. (mm) .....	4.25 x 5.00 (108 x 127)
Displacement - in. <sup>3</sup> (L) .....	426 (7.0)
Compression Ratio .....	17:1
Valves per Cylinder	
Intake .....	None
Exhaust .....	4
Combustion System .....	Direct Injection
Engine Type .....	63.5° VEE - 2 Cycle
Aspiration .....	Turbocharged
Firing Order (CW Rotation) .....	1R-1L-3R-3L-2R-2L
Turbocharger .....	1.39 A/R
Charge Air Cooling Type .....	None
Blower Type .....	Roots By-Pass
Blower Drive Ratio .....	2.00:1
Rotation (Viewed from Front)	
Clockwise .....	Standard
Counter-Clockwise .....	Optional
Engine Crankcase Vent System .....	Open
Dimensions and Weight	
Length - in. (mm) (From Drive Flange) .....	45.60 (1158)
Width - in. (mm) .....	41.02 (1042)
Height - in. (mm) (Above Crankshaft Center Line) .....	43.75 (1111)
Weight, Dry - lb. (kg) .....	2205 (1000)
Wet - lb. (kg) .....	2313 (1049)
Installation Drawing .....	D-433

**Cooling System**

	<b>1470</b>	<b>1760</b>	<b>1900</b>	<b>2100</b>	<b>2350</b>
Heat Exchanger Minimum Flow					
60°F Raw H <sub>2</sub> O - gal./min. (L/min.) .....	9 (34)	13 (49)	15 (57)	17 (64)	18 (68)
95°F Raw H <sub>2</sub> O - gal./min. (L/min.) .....	14 (53)	17 (64)	19 (72)	22 (83)	23 (87)
Engine H <sub>2</sub> O Heat - Btu/sec. (kw/sec.) .....	85 (1.5)	130 (2.3)	150 (2.6)	152 (2.7)	169 (3.0)
Engine Radiated Heat - Btu/sec. (kw/sec.) .....			42 (0.7)		
Thermostat, Start to Open - °F (°C) .....			177 (81)		
Fully Open - °F (°C) .....			197 (92)		
Engine Coolant Capacity - qt. (L) .....			49 (46)		
Coolant Pressure Cap - lb./in. <sup>2</sup> (kPa) .....			9 (62)		
Maximum Engine H <sub>2</sub> O Temperature - °F (°C) .....			200 (93)		
Minimum Engine H <sub>2</sub> O Temperature - °F (°C) .....			160 (71)		
Heat Exchanger Maximum Raw H <sub>2</sub> O					
Inlet Pressure - lb./in. <sup>2</sup> (kPa) .....			20 (138)		

**Electric System - DC**

	<b>All Speeds</b>
System Voltage (Nominal) .....	24
Battery Capacity for Ambients Above 32°F - CCA @ 0°F .....	900
Voltage (Nominal) .....	12
Qty. per Battery Bank .....	2
SAE size per J537 .....	8D-900
Battery Cable Circuit*, Max Resistance - ohm .....	0.002
Battery Cable Minimum Size	
0-225 in. Circuit* Length .....	No. 00
225-300 in. Circuit* Length .....	No. 000
301-380 in. Circuit* Length .....	No. 0000
Charging Alternator Output - Amp. ....	40
Starter Cranking Amps - @ 40° F .....	595

\*Positive and Negative Cables Combined Length

Note: This Engine Is Intended For Indoor Installation Or In A Weatherproof Enclosure.

(Continued)

# DDFP-T6VT INSTALLATION & OPERATION DATA

## Basic Engine Description

Engine Manufacturer .....  
 Ignition Type .....  
 Number of Cylinders .....  
 Bore and Stroke - in. (mm) .....  
 Displacement - in.<sup>3</sup> (L) .....  
 Compression Ratio .....  
 Valves per Cylinder  
     Intake .....  
     Exhaust .....  
 Combustion System .....  
 Engine Type .....  
 Aspiration .....  
 Firing Order (CW Rotation) .....  
 Turbocharger .....  
 Charge Air Cooling Type .....  
 Blower Type .....  
 Blower Drive Ratio .....  
 Rotation (Viewed from Front)  
     Clockwise .....  
     Counter-Clockwise .....  
 Engine Crankcase Vent System .....  
 Dimensions and Weight  
     Length - in. (mm) (From Drive Flange) .....  
     Width - in. (mm) .....  
     Height - in. (mm) (Above Crankshaft Center Line) .....  
     Weight, Dry - lb. (kg) .....  
     Wet - lb. (kg) .....  
 Installation Drawing .....

## All Speeds

Detroit Diesel Corp.  
 Compression (Diesel)  
 6  
 4.25 x 5.00 (108 x 127)  
 426 (7.0)  
 17:1  
  
 None  
 4  
 Direct Injection  
 63.5° VEE - 2 Cycle  
 Turbocharged  
 1R-1L-3R-3L-2R-2L  
 1.39 A/R  
 None  
 Roots By-Pass  
 2.00:1  
  
 Standard  
 Optional  
 Open  
  
 45.60 (1158)  
 41.02 (1042)  
 43.75 (1111)  
 2205 (1000)  
 2313 (1049)  
 D-433

## Cooling System

	<u>1470</u>	<u>1760</u>	<u>1900</u>	<u>2100</u>	<u>2350</u>
Heat Exchanger Minimum Flow					
60°F Raw H <sub>2</sub> O - gal./min. (L/min.) .....	11 (42)	14 (53)	17 (64)	18 (68)	20 (76)
95°F Raw H <sub>2</sub> O - gal./min. (L/min.) .....	18 (68)	19 (72)	24 (91)	25 (95)	28 (106)
Engine H <sub>2</sub> O Heat - Btu/sec. (kw/sec.) .....	105 (1.9)	137 (2.4)	154 (2.7)	161 (2.8)	175 (3.1)
Engine Radiated Heat - Btu/sec. (kw/sec.) .....			42 (0.7)		
Thermostat, Start to Open - °F (°C) .....			177 (81)		
Fully Open - °F (°C) .....			197 (92)		
Engine Coolant Capacity - qt. (L) .....			49 (46.4)		
Coolant Pressure Cap - lb./in. <sup>2</sup> (kPa) .....			9 (62)		
Maximum Engine H <sub>2</sub> O Temperature - °F (°C) .....			200 (93)		
Minimum Engine H <sub>2</sub> O Temperature - °F (°C) .....			160 (71)		
Heat Exchanger Maximum Raw H <sub>2</sub> O Inlet Pressure - lb./in. <sup>2</sup> (kPa) .....					20 (138)

## Electric System - DC

System Voltage (Nominal) .....  
 Battery Capacity for Ambients Above 32°F - CCA @ 0°F .....  
     Voltage (Nominal) .....  
     Qty. per Battery Bank .....  
     SAE size per J537 .....  
 Battery Cable Circuit\*, Max Resistance - ohm .....  
 Battery Cable Minimum Size  
     0-225 in. Circuit\* Length .....  
     225-300 in. Circuit\* Length .....  
     301-380 in. Circuit\* Length .....  
 Charging Alternator Output - Amp .....  
 Starter Cranking Amps - @ 40° F .....

## All Speeds

24  
 900  
 12  
 2  
 8D-900  
 0.002  
  
 No. 00  
 No. 000  
 No. 0000  
 40  
 595

\*Positive and Negative Cables Combined Length

Note: This Engine Is Intended For Indoor Installation Or In A Weatherproof Enclosure.

(Continued)

# DDFP-T6VT INSTALLATION & OPERATION DATA (Continued)

<b>Exhaust System</b>	<b>1470</b>	<b>1760</b>	<b>1900</b>	<b>2100</b>	<b>2350</b>
Exhaust Flow - ft. <sup>3</sup> /min. (m <sup>3</sup> /min.) .....	1892 (54)	2159 (61)	2300 (65)	2488 (70)	2553 (72)
Exhaust Temperature - °F (°C) .....	708 (376)	740 (393)	759 (386)	776 (413)	772 (411)
Maximum Allowable Back Pressure -					
in. H <sub>2</sub> O (kPa) .....	19 (4.7)	24 (6.1)	26 (6.6)	29 (7.4)	33 (8.4)
Min. Exhaust Pipe Dia.-in. (mm)** .....	5 (127)	5 (127)	5 (127)	6 (152)	6 (152)

<b>Fuel System</b>					
Fuel Pressure - lb./in. <sup>2</sup> (kPa) .....	58 (400)	62 (428)	63 (435)	64 (442)	65 (449)
Fuel Consumption - gal./hr. (L/hr.) .....	14 (53)	17 (64)	18 (68)	19 (72)	20 (76)
Fuel Return Rate - gal./hr. (L/hr.) .....	63 (239)	71 (269)	74 (280)	80 (303)	83 (315)
Total Fuel Flow - gal./hr. (L/hr.) .....	77 (291)	88 (333)	92 (348)	99 (375)	103 (390)
Minimum Line Size - Supply - in. (mm)** .....			.75 (19) Sch. 40 - Black		
Return - in. (mm)** .....			.50 (13) Sch. 40 - Black		
Maximum Allowable Fuel Pump Suction					
Clean System - in. H <sub>2</sub> O (kPa) .....			82 (20)		
Dirty System - in. H <sub>2</sub> O (kPa) .....			164 (40)		
Fuel Filter Micron Size - Primary .....			30		
Secondary .....			12		
Fuel Injector/Timing - in. (mm) .....			/1.508 (38.303)		
Fuel Modulator/Setting .....			None		

<b>Heater System</b>	<b>All Speeds</b>
Jacket Water Heater .....	Standard
Wattage (Nominal) .....	2500
Voltage, Reconnectable - VAC, 1P .....	120/208/240
Other Voltages .....	Optional
Lube Oil Heater (Required When Ambient Is Below 50°F (10°C)) .....	Optional
Wattage .....	125

<b>Induction Air System</b>	<b>1470</b>	<b>1760</b>	<b>1900</b>	<b>2100</b>	<b>2350</b>
Air Cleaner Type .....	Indoors Service Only - Washable				
Air Intake Restriction Maximum Limit					
Dirty Air Cleaner - in. H <sub>2</sub> O (kPa) .....	11.0 (2.7)	11.5 (2.9)	12.0 (3.0)	13.0 (3.2)	14.0 (3.5)
Clean Air Cleaner - in. H <sub>2</sub> O (kPa) .....	9.0 (2.2)	9.5 (2.4)	10.0 (2.5)	11.0 (2.7)	12.0 (3.0)
Engine Air Flow - ft. <sup>3</sup> /min. (m <sup>3</sup> /min.) .....	870 (24.6)	966 (27.3)	1013 (28.7)	1081 (30.6)	1113 (31.5)

<b>Lubrication System</b>	<b>All Speeds</b>
Oil Pressure - normal - lb./in. <sup>2</sup> (kPa) .....	40-70 (276-433)
In Pan Oil Temperature - °F (°C) .....	220-240 (88-116)
Oil Pan Capacity - High - qt. (L) .....	20 (19)
Low - qt. (L) .....	16 (15)
Total Oil Capacity with Filters - qt. (L) .....	22 (21)

<b>Performance</b>	<b>1470</b>	<b>1760</b>	<b>1900</b>	<b>2100</b>	<b>2350</b>
BMEP - lb./in. <sup>2</sup> (kPa) .....	161 (1110)	160 (1103)	157 (1082)	151 (1041)	138 (951)
Piston Speed - ft./min. (m/min.) .....	1225 (373)	1467 (447)	1583 (483)	1750 (583)	1958 (597)
Noise - dB (A) @ 1m .....					
Power Curve .....	CDDA - 7064 - 02				

\*\*Based On Nominal System. Flow Analysis Must Be Done To Assure Adherence To System Limitations.  
(Minimum Exhaust Pipe Diameter is based on 15 feet of pipe, one elbow, and a silencer  
pressure drop no greater than one half the max. allowable back pressure.)

I N T R O D U C I N G  
DDFP-L6VT & DDFP-T6VT

These new engines are being introduced to replace models L6AT/T6AT. The essential physical change involves the engine block configuration. The old engine had an "Inline" cylinder arrangement and the new engine has a "Vee" block cylinder arrangement. The "Vee" block engine models will be ready for shipment in Jan '93. The new units have FM-UL-ULC approval.

**Features & Benefits for the Pump Manufacturer**

High Efficiency Heat Exchangers

- Reduces raw water flow requirement
- Reduces cost of cooling loop

Falk 1080T10 coupling

- Reduces OEM assembly cost
- Standardizes drive coupling system

Vertical Turbine Drive Plate Option

- No additional cost for this option
- Covers 61, 71, 81, 88 & 91 Series drive flanges

Stub Shaft Option

- Available at an additional charge
- 2.25" diameter, same as used on T6AT

Engine Size

- Reduces length of pump package

Existing Mounting Design

- Same foot print as 06FA engine
- 3/8" shorter (coupling face to mounting holes)

Performance

- Same performance BHP & RPM

Pricing

- Same low price as Inline engines.

24 VDC Standard

- Reduces battery charger cost







FIRE PUMP MODEL DDFP-L6VT  
 6V71T INDUSTRIAL  
 HEAT EXCHANGER COOLED  
 INJECTOR, 1.508 TIMING  
 TV7302 TURBOCHARGER (1.39 A/R)  
 NO CHARGE COOLING.

ACTUAL ENGINE PERFORMANCE  
 CORRECTED TO SAE STD. CONDITIONS:  
 77°F AIR INLET TEMPERATURE  
 29.61 IN. HG BAROMETRIC PRESSURE  
 WITNESSED & VALIDATED BY UNDERWRITERS  
 LABORATORIES, INC., FACTORY MUTUAL  
 RESEARCH & UNDERWRITERS' LABORATORIES  
 OF CANADA.

*J. T. Whitney*  
 J. T. WHITNEY 7/11/92

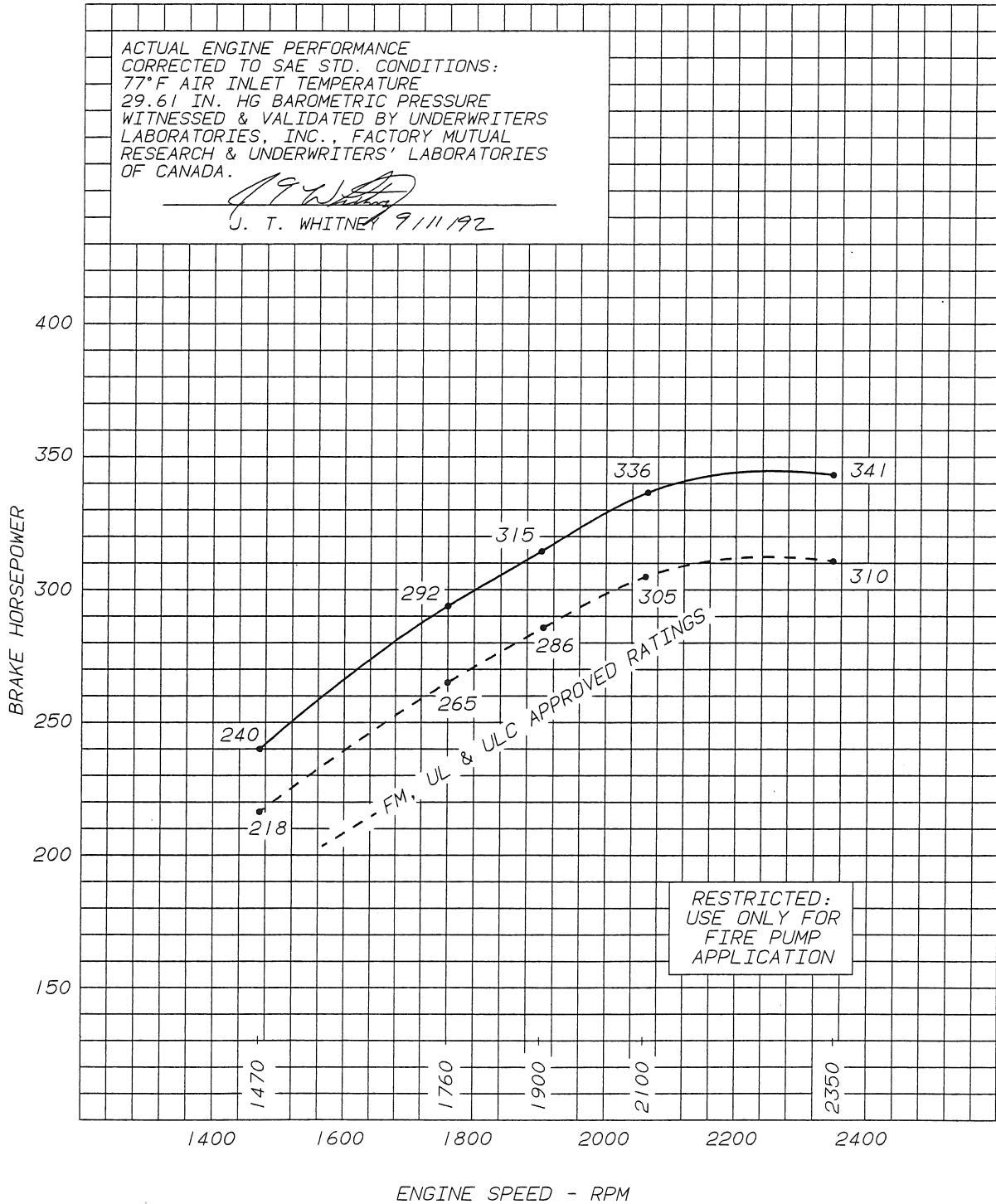

RESTRICTED:  
 USE ONLY FOR  
 FIRE PUMP  
 APPLICATION



FIRE PUMP MODEL DDFP-T6VT  
 6V71T INDUSTRIAL  
 HEAT EXCHANGER COOLED  
 INJECTOR, 1.508 TIMING  
 TV7302 TURBOCHARGER (1.39 A/R)  
 NO CHARGE COOLING.

ACTUAL ENGINE PERFORMANCE  
 CORRECTED TO SAE STD. CONDITIONS:  
 77°F AIR INLET TEMPERATURE  
 29.61 IN. HG BAROMETRIC PRESSURE  
 WITNESSED & VALIDATED BY UNDERWRITERS  
 LABORATORIES, INC., FACTORY MUTUAL  
 RESEARCH & UNDERWRITERS' LABORATORIES  
 OF CANADA.

*J. T. Whitney*  
 J. T. WHITNEY 9/11/92

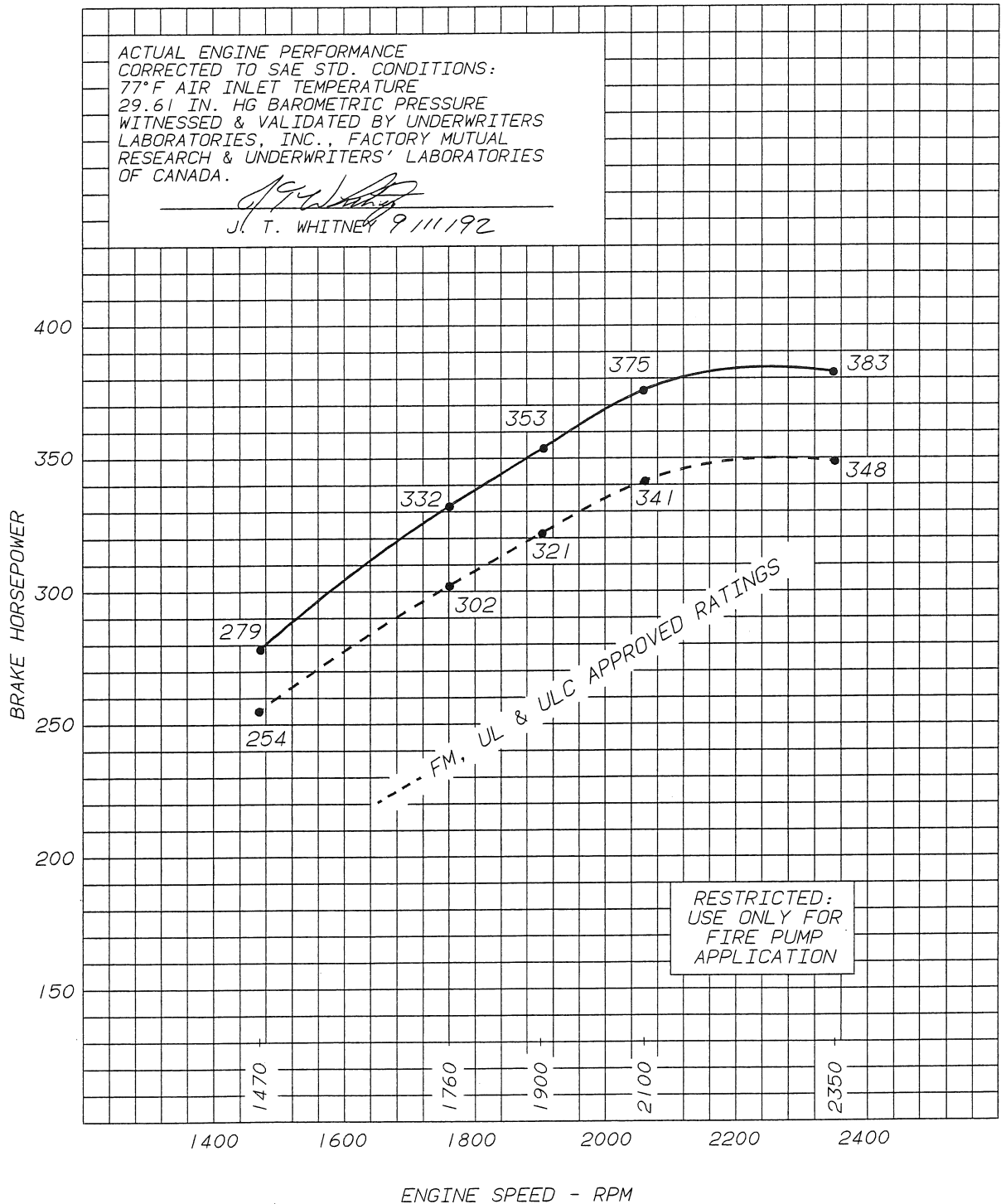

RESTRICTED:  
 USE ONLY FOR  
 FIRE PUMP  
 APPLICATION

# DDFP-L6VT, -T6VT

## ENGINE MATERIALS AND CONSTRUCTION

### Air Cleaner

Type ..... Indoor Usage Only  
Oiled Fabric Pleats  
Material ..... Surgical Cotton  
Aluminum Mesh

### Camshaft

Material ..... Forged Steel  
Location ..... In Block, 1 Per Bank  
Drive ..... Gear  
Type of Cam ..... Ground

### Camshaft Bearing - End

Journal Diameter ..... 1.50 in. (38.0 mm)  
Length ..... 2.12 in. (53.8 mm)  
Material ..... Steel Backed Bronze

### Camshaft Bearing - Intermediate

Journal Diameter ..... 1.50 in. (38.0 mm)  
Length ..... 1.32 in. (33.5 mm)  
Materials ..... Aluminum

### Connecting Rod

Type ..... Forged I Section  
Material ..... Forged Steel (SAE 1141)

### Crank Pin Bearings

Type ..... Precision Half Shell  
Number ..... 1 Pair Per Cylinder  
Journal Diameter ..... 3.00 in. (76.2 mm)  
Length ..... 1.20 in. (30.5 mm)  
Projected Area/Bearing ..... 3.60 in.<sup>2</sup> (2323 mm<sup>2</sup>)  
Material ..... Steel Backed Copper Lead

### Crankshaft

Material ..... Steel (SAE 1548)  
Heat Treat ..... Induction Hardened  
Type of Balance ..... Dynamic

### Cylinder Block

Type ..... One Piece  
Material ..... Cast Iron

### Cylinder Head

Type ..... Slab 4 Valve  
Material ..... Cast Iron

### Exhaust Valve

Type ..... Poppet  
Arrangement ..... Overhead Valve  
Number/Cylinder ..... 4  
Operating Mechanism ..... Mechanical Rocker Arm  
Type of Lifter ..... Roller  
Valve Spring  
Number/Valve ..... 1  
Valve Seat Insert  
Material ..... Cast Eatonite

### Heat Exchanger

Type ..... Tube & Shell  
Materials  
Tubes & Headers ..... 90/10 CU/NI  
Shell ..... Copper  
Electrode ..... Zinc

### Liners

Type ..... Wet Liner  
Material ..... Cast Iron  
Ports  
Type ..... Oval  
Number ..... 18

### Main Bearings

Type ..... Precision Half Shells  
Journal Diameter ..... 4.50 in. (114.3 mm)  
Length ..... 1.24 in. (31.5 mm)  
Projected Area/Bearing ..... 5.58 in.<sup>2</sup> (3600 mm<sup>2</sup>)  
Material ..... Steel Backed Copper Lead

### Piston

Type and Material ..... Crosshead Malleable Iron  
Cooling ..... Oil - Cocktail Shaker

### Piston Pin Bushing

Material ..... Steel Backed Bronze

### Piston Rings - Compression

Type  
Top Ring ..... Chrome Faced Keystone  
Remaining 2 ..... Barrel And Chrome Faced

### Piston Rings - Oil

Type ..... Double Scraper with Expander  
Number per Piston ..... 2 Sets  
Location ..... Bottom of Skirt

### Piston Pin

Type ..... Crosshead - Polished & Hardened

**DDFP-L6VT**  
**FIRE PUMP DRIVER**  
**EMISSION DATA**

*To complete an application for a Permit to Operate, the following data is provided.*

6 Cylinders  
 Two Cycle  
 Lean Burn  
 Turbocharged  
 Diesel Oil - Fuel  
 No - Energy Recovery from Exhaust  
 No - Emission Control Device

RPM	BHP	FUEL GAL / HR	AIR/FUEL RATIO	GM / BHP / HR					% O <sub>2</sub>	EXHAUST		TIMING DEGREES
				HC	NO <sub>x</sub>	CO	SO <sub>2</sub>	PART.		°F	CFM	
2350	310	17.3	38.9	0.55	17.8	2.90	0.67	0.20	13.3	731	2318	6.8
2100	305	16.4	38.4	0.42	17.3	3.44	0.68	0.32	13.2	742	2191	6.8
1900	286	15.2	38.6	0.38	10.2	4.70	0.67	0.46	13.3	736	2031	6.8
1760	265	14.1	39.2	0.38	10.0	6.26	0.68	0.58	13.4	727	1939	6.8
1470	218	11.9	41.1	0.39	18.3	7.80	0.69	0.69	13.7	684	1619	6.8

*For specific RPM & BHP ratings, some of the above data may have been extrapolated from the best available test data.*

*Degrees of timing RETARD for 'beginning of injection' based on comparison with pre-emission controlled engines from the same family.*

*Sulfur Dioxide based on 0.2% sulfur content in fuel (by weight).*

7064-7312 Base Model Engine Manufactured by Detroit Diesel Corp.  
 1.39 A/R Turbocharger  
 115MM Fuel Injectors @ 1.508 Timing Height

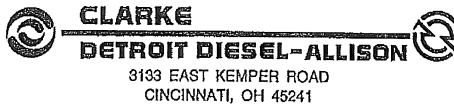

# DDFP-T6VT

## FIRE PUMP DRIVER

### EMISSION DATA

*To complete an application for a Permit to Operate, the following data is provided.*

**6 Cylinders**  
**Two Cycle**  
**Lean Burn**  
**Turbocharged**  
**Diesel Oil - Fuel**  
**No - Energy Recovery from Exhaust**  
**No - Emission Control Device**

RPM	BHP	FUEL GAL / HR	AIR/FUEL RATIO	GM / BHP / HR					% O <sub>2</sub>	EXHAUST		TIMING DEGREES
				HC	NOx	CO	SO <sub>2</sub>	PART.		°F	CFM	
2350	348	19.3	37.1	0.44	13.7	6.3	1.75	0.20	12.9	772	2553	8.5
2100	341	18.5	37.6	0.36	13.8	6.8	1.72	0.33	13.0	776	2488	8.5
1900	321	17.5	37.3	0.30	12.4	11.3	1.73	0.47	12.9	759	2300	8.5
1760	302	16.7	37.2	0.23	11.6	15.7	1.75	0.59	12.9	740	2159	8.5
1470	254	14.4	38.9	0.16	7.7	29.1	1.83	0.70	13.3	708	1892	8.5

*For specific RPM & BHP ratings, some of the above data may have been extrapolated from the best available test data.*

*Degrees of timing RETARD for 'beginning of injection' based on comparison with pre-emission controlled engines from the same family.*

7064-7312 Base Model Engine Manufactured by Detroit Diesel Corp.  
 1.39 A/R Turbocharger  
 115MM Fuel Injectors @ 1.508 Timing Height



3133 EAST KEMPER ROAD  
 CINCINNATI, OH 45241



**ALASKA INDUSTRIAL DEVELOPMENT AND EXPORT AUTHORITY  
AND ALASKA ENERGY AUTHORITY**

**CERTIFICATION OF CONTRACTOR AND LOWER-TIER PARTICIPANTS  
REGARDING DEBARMENT, SUSPENSION, AND OTHER INELIGIBILITY AND  
VOLUNTARY EXCLUSION**

Contractor

*PLEASE INSERT YOUR COMPANY'S NAME AND ADDRESS IN THIS BOX*

I, \_\_\_\_\_ hereby certify on behalf  
(Name and title of official)

of \_\_\_\_\_ that:  
(Name of contractor)

- (1) The prospective contractor and lower tier participant certifies, by submission of this bid or proposal, that neither it nor its "principals" [as defined at 49 C.F.R. § 29.105(p)] is presently debarred, suspended, proposed for debarment, declared ineligible, or voluntarily excluded from participation in this transaction by any Federal department or agency. In the event, your company or any principals become ineligible from participating in federally funded transactions, you are required to notify us immediately.
- (2) When the prospective contractor and lower tier participant is unable to certify to the statements in this certification, such prospective participant shall attach an explanation to this proposal.

Executed this \_\_\_\_\_ day of \_\_\_\_\_, 20\_\_

By:

\_\_\_\_\_  
(Signature of authorized official)

\_\_\_\_\_  
(Title of authorized official)