



**INVITATION TO BID  
17047**

**CONSTRUCTION**

**Rural Power System Upgrade (RPSU)  
Electrical and Mechanical Installation  
On behalf of  
The City of Kake and Kipnuk, Alaska**

**November 2016**

This page is blank intentionally.

## TABLE OF CONTENTS

### Division 0 - Bidding and Contract Requirements (yellow)

<u>Section</u>	<u>Form</u>	<u>Date</u>
<u>Invitation (yellow)</u>		
00020 INVITATION TO BID	25D-7	(8/01)
<u>Bid Notices (yellow)</u>		
00100 INFORMATION TO BIDDERS	25D-3	(7/88)
00101 SUPPLEMENTARY INFORMATION TO BIDDERS		(12/88)
00120 REQUIRED DOCUMENTS	25D-4	(4/12)
<u>Forms (yellow)</u>		
00310 PROPOSAL	25D-9A	(07/03)
00320 BID SCHEDULE		
00410 BID BOND	25D-14	(8/01)
00420 BID MODIFICATION	25D-16	(8/01)
00430 SUBCONTRACTOR LIST	25D-5	(10/12)
00510 CONSTRUCTION CONTRACT	25D-10A	(8/01)
00610 PERFORMANCE BOND	25D-13	(8/01)
00620 PAYMENT BOND	25D-12	(8/01)
00670 CONTRACTOR'S QUESTIONNAIRE	25D-8	(8/01)

### Contract Provisions and Specifications (white)

00700 GENERAL CONDITIONS		
00800 SUPPLEMENTARY CONDITIONS		
00900 FEDERAL TERMS AND CONDITIONS		

### SCOPE OF WORK

#### **DRAWINGS**

Kake Module M3.1 95%  
KipnukModule M3.1 95%  
Kipnuk and Kake Modules at Shop Option #2

ALASKA ENERGY AUTHORITY

**INVITATION TO BID**

for Construction Contract

Date 11/2/2016

**Rural Power System Upgrade (RPSU)  
Electrical and Mechanical Installation  
On Behalf Of Kipnuk and Kake**

Location of Project: Anchorage, Alaska  
Contracting Officer: Rich S. Wooten, CDT, CPSM  
Issuing Office: ALASKA ENERGY AUTHORITY (AUTHORITY)  
State Funded [ ] Federal Aid [ x]

Description of Work:

The State of Alaska, Alaska Energy Authority (AEA) is administering two power system upgrade projects on behalf of two entities: the Native Village of Kipnuk and the Inside Passage Electric Cooperative ("IPEC", serving Kake). The new power generation facilities will be housed in two modular steel structures: The Kipnuk module is 17'x 56' and the Kake module is 17' x 66'. Both modules will be assembled and tested in Anchorage at the Alaska Energy Authority shop located at 2601 Commercial Drive. The modules will then be commissioned, packaged and shipped to the communities for installation by others. This project includes installation of: diesel generators; exhaust, fuel and hydronic piping; holding and expansion tanks; automatic paralleling switchgear; and supporting mechanical, electrical, and control systems. This contract is for a licensed contractor (Contractor) to provide labor only to perform the installation of all electrical and mechanical systems.

The Engineer's Estimate is between **\$500,000 and \$750,000**

All work shall be completed by: **June 15, 2017**

Interim Completion dates, if applicable, will be shown in the General Requirements.

**Bidders are invited to submit sealed bids, in single copy, for furnishing labor for performing all work for the project described above. Bids will be opened publicly at 2:00 pm local time, in the Willow conference room, 813 West Northern Lights Blvd., Anchorage, Alaska on November 23, 2016.**

**SUBMISSION OF BIDS**

ALL BIDS INCLUDING ANY AMENDMENTS OR WITHDRAWALS MUST BE RECEIVED PRIOR TO BID OPENING. BIDS SHALL BE SUBMITTED ON THE FORMS FURNISHED AND MUST BE IN A SEALED ENVELOPE MARKED AS FOLLOWS:

<b>Bid for Project:</b> <b>Rural Power System Upgrade (RPSU)</b> <b>Electrical and Mechanical Installation</b> <b>Project Number:17047</b>	<b>ATTN: Contracts</b> <b>Alaska Energy Authority</b> <b>813 West Northern Lights Blvd.</b> <b>Anchorage, AK 99503</b>
---	---

Bids, amendments or withdrawals transmitted by mail must be received in the above specified post office box no later than 7 hours prior to the scheduled time of bid opening. Hand-delivered bids, amendments or withdrawals must be received by the **Front Desk of the Alaska Energy Authority**, prior to the scheduled time of bid opening. Faxed/emailed bid amendments must be addressed to **Rich Wooten, CDT, CPSM** Fax number: (907) 771-3044, Email: rwooten@aidea.org.

*A bid guaranty is required with each bid in the amount of 5% of the amount bid. (Alternate bid items as well as supplemental bid items appearing on the bid schedule shall be included as part of the total amount bid when determining the amount of bid guaranty required for the project.)*

The Authority hereby notifies all bidders that it will affirmatively insure that in any contract entered into pursuant to this Invitation, Disadvantaged Business Enterprises (DBEs) will be afforded full opportunity to submit bids and will not be discriminated against on the grounds of race, color, national origin, or sex in consideration for an award.

## NOTICE TO BIDDERS

---

Bidders are hereby notified that data to assist in preparing bids is available as follows:

See attached Special Notice to Bidders for this project.

---

Electronic Plans and Specifications may be ordered, for the price of \$0.00 from:

**Alaska Energy Authority**  
**813 West Northern Lights Blvd.**  
**Anchorage, AK 99503**

Phone: (907) 771-3019

---

All questions relating to design features, constructability, quantities, or other technical aspects of the project should be directed to the following. Bidders requesting assistance in viewing the project must make arrangements at least 48 hours in advance with:

**Alan Fetters** Phone: (907) 771-6063

Fax: (907) 771-3044

---

All questions concerning bidding procedures should be directed to:

**Rich Wooten, CDT, CPSM.**  
**Contracting Officer**  
**813 West Northern Lights Blvd.**  
**Anchorage, AK 99503**

Phone: (907) 771-3019

---

**The Bid Calendar, Planholder lists, and Bid Results information are available on the Internet at: [www.aidea.org](http://www.aidea.org) under Procurement Opportunities.**

**Reminder: 3 AAC 109.220 requires all Bidders to have a valid Alaska Business License and an Alaska Contractor's Certificate of Registration prior to award. To qualify as an Alaska bidder under 3 AAC 109.220, a bidder shall have a valid Alaska business license at time designated in the invitation to bid for bid opening.**

### **Special Notice to Bidders**

1. A non-mandatory pre-bid meeting is scheduled for November 9, 2016, 10:00am at the AEA Warehouse. The AEA Warehouse is located at 2601 Commercial Dr., Anchorage, AK 99503.

**ALASKA ENERGY AUTHORITY**  
**INFORMATION TO BIDDERS**

The Authority is concerned over the manner in which bids are submitted. Bidders are requested to study and follow the bid assembly instructions as to the method and form for submitting bids so there will be no reason to reject a bid.

**EXAMINATION OF CONTRACT REQUIREMENTS**

Bidders are expected to examine carefully the plans, specifications and all other documents incorporated in the contract to determine the requirements thereof before preparing bids.

Any explanation desired by bidders regarding the meaning or interpretation of drawings and specifications must be requested in writing and with sufficient time allowed for a reply to reach them before the submission of their bids. Oral explanations or instructions given before the award of the contract will not be binding. Any interpretation made will be in the form of an addendum to the specifications or drawings and will be furnished to all bidders and its receipt by the bidder shall be acknowledged.

**PREPARATION OF BIDS**

- (a) Bids shall be submitted on the forms furnished, and must be manually signed in ink. The person signing the proposal must initial any erasures or changes made to the bid.
- (b) The bid schedule will provide for quotation of a price or prices for one or more pay items which may include unit price or lump sum items and alternative, optional or supplemental price schedules or a combination thereof which will result in a total bid amount for the proposed construction.

Where required on the bid form, bidders must quote on all items and **THEY ARE WARNED** that failure to do so will disqualify them. When quotations on all items are not required, bidders should insert the words "no bid" in the space provided for any item not requiring a quotation and for which no quotation is made.

- (c) The bidder shall specify the price or prices bid in figures. On unit price contracts the bidder shall also show the products of the respective unit prices and quantities written in figures in the column provided for the purpose and the total amount of the proposal obtained by adding the amounts of the several items. All the figures shall be in ink or typed.
- (d) Neither conditional nor alternative bids will be considered unless called for.
- (e) Unless specifically called for, telegraphic or telefacsimile bids will not be considered.
- (f) Bid Schedule form should be enclosed in a separate sealed envelope and enclosed with all other bidding forms required at the opening.

## **BID SECURITY**

All bids shall be accompanied by a bid security in the form of an acceptable Bid Bond (Form 25D-14), or a certified check, cashier's check or money order made payable to the State of Alaska. The amount of the bid security is specified on the Invitation To Bid.

Bid Bonds must be accompanied by a legible Power of Attorney.

If the bidder fails to furnish an acceptable bid security with the bid, the bid shall be rejected as non-responsive. Telegraphic notification of execution of Bid Bond does not meet the requirements of bid security accompanying the bid. An individual surety will not be accepted as a bid security.

The Authority will hold the bid securities of the two lowest bidders until the Contract has been executed, after which they will be returned. All other bid securities will be returned as soon as practicable.

## **BIDDERS QUALIFICATIONS**

Before a bid is considered for award, the bidder may be requested by the Authority to submit a statement of facts, in detail, as to his previous experience in performing comparable work, his business and technical organization, financial resources, and plant available to be used in performing the contemplated work.

## **SUBMISSION OF BIDS**

Bids must be submitted as directed on the Invitation To Bid. Do not include in the envelope any bids for other work.

## **ADDENDA REQUIREMENTS**

The bid documents provide for acknowledgement individually of all addenda to the drawings and/or specifications on the signature page of the Proposal. All addenda shall be acknowledged on the Proposal or by telegram prior to the scheduled time of bid opening. If the bidder received no addenda, the word "None" should be shown as specified.

Every effort will be made by the Authority to insure that Contractors receive all addenda when issued. Addenda will be issued to the individual or company to whom bidding documents were issued. Addenda may be issued by any reasonable method such as hand delivery, mail, telefacsimile, telegraph, courier, and in special circumstances by phone. Addenda will be issued to the address, telefacsimile number or phone number as stated on the planholder's list unless picked up in person or included with the bid documents. It is the bidder's responsibility to insure that he has received all addenda affecting the Invitation To Bid. No claim or protest will be allowed based on the bidder's allegation that he did not receive all of the addenda for an Invitation To Bid.

## **WITHDRAWAL OR REVISION OF BIDS**

A bidder may withdraw or revise a bid after it has been deposited with the Authority, provided that the request for such withdrawal or revision is received by the designated office, in writing, by telegram, or by telefacsimile, before the time set for opening of bids.

Emailed or telefacsimile modifications shall include both the modification of the unit bid price and the total modification of each item modified, but shall not reveal the amount of the total original or revised bids. Form 25D-16 shall be used to submit such modifications.



## **RECEIPT AND OPENING OF BIDS**

- (a) The Authority must receive all bids, including any amendment or withdrawal prior to the scheduled time of bid opening. Any bid, amendment, or withdrawal that has not actually been received by the Authority prior to the time of the scheduled bid opening will not be considered.
- (b) No responsibility will be attached to any officer or employee of the Authority for the premature opening of, or failure to open, a bid improperly addressed or identified.
- (c) The Authority reserves the right to waive any technicality in bids received when such waiver is in the interest of the State.

## **BIDDERS PRESENT**

At the time fixed for bid opening, bids will be publicly opened and read for the information of bidders and others properly interested, who may be present either in person or by representative. The amount of the bid and the name of the bidder shall be compiled and distributed as soon as possible after bid opening. Bids are not open for public inspection until after the Notice of Intent to Award is issued.

## **BIDDERS INTERESTED IN MORE THAN ONE BID**

If more than one bid is offered by any one party, by or in the name of his or their clerk or partner, all such bids will be rejected. A party who has quoted prices to a bidder is not thereby disqualified from quoting prices to other bidders or from submitting a bid directly for the work.

## **REJECTION OF BIDS**

The Authority reserves the right to reject any and all bids when such rejection is in the best interest of the State; to reject the bid of a bidder who has previously failed to perform properly, or complete on time, contracts of a similar nature; to reject the bid of a bidder who is not, in the opinion of the Contracting Officer, in a position to perform the contract; and to reject a bid as non-responsive where the bidder fails to furnish the required documents, fails to complete required documents in the manner directed, or makes unauthorized alterations to the bid documents.

## **AWARD OF CONTRACT**

- (a) The letter of award, if the contract is to be awarded, will be issued to the lowest responsible and responsive bidder as soon as practical and usually within 40 calendar days after opening of proposals.
- (b) The successful bidder will be notified of the Authority's intent to award the contract and requested to execute certain documents, including the contract form and bonds.
- (c) The contract will be awarded to the successful bidder following receipt by the Authority of all required documents, properly executed, within the time specified in the intent to award. Failure to enter into a contract within the specified time shall be grounds for forfeiture of the bid security and consideration of the second low bidder for award.

## ALASKA ENERGY AUTHORITY

### SUPPLEMENTARY INFORMATION TO BIDDERS

This document modifies or adds to the provisions of the Alaska Energy Authority's form 25D-3, INFORMATION TO BIDDERS.

Following subject area "REJECTION OF BIDS", add the following subject area:

#### "CONSIDERATION OF PROPOSALS

After the Proposals are opened and read, they will be compared on the basis identified on the bid schedule and the apparent low Bidder announced. The apparent low Bidder shall, within 5 working days following identification as the apparent low Bidder, submit a list of all firms with which the prime CONTRACTOR intends to execute subcontracts for the performance of the Contract. The list shall include the name, business address, Alaska business license number and contractor's registration number of each proposed Subcontractor.

Upon confirmation of the contents of the proposal the low Bidder will be identified by the AUTHORITY by email. If the low Bidder differs from the apparent low Bidder then the requirements for Subcontractor listing, as noted above, shall become effective upon the low Bidder at the time of identification.

If a Bidder fails to list a Subcontractor or lists more than one Subcontractor for the same portion of Work and the value of that Work is in excess of one-half of one percent of the total bid, the Bidder agrees that it shall be considered to have agreed to perform that portion of Work without the use of a Subcontractor and to have represented that the Bidder is qualified to perform the Work.

A Bidder who attempts to circumvent the requirements of this section by listing as a Subcontractor another contractor who, in turn, sublets the majority of the Work required under the Contract, violates this section.

If a Contract is awarded to a Bidder who violates this section, the Bidder agrees that the Contracting Officer may:

- (1) cancel the Contract without any damages accruing to the State; or
- (2) after notice and a hearing, assess a penalty on the Bidder in an amount that does not exceed 10 percent of the value of the Subcontract at issue.

A Bidder may replace a listed Subcontractor who:

- (1) fails to comply with AS 08.18;
- (2) files for bankruptcy or becomes insolvent;
- (3) fails to execute a contract with the Bidder involving performance of the Work for which the Subcontractor was listed and the Bidder acted in good faith;
- (4) fails to obtain bonding;
- (5) fails to obtain insurance acceptable to the State;
- (6) fails to perform the Contract with the Bidder involving Work for which the Subcontractor was listed;
- (7) must be substituted in order for the prime CONTRACTOR to satisfy required State and Federal affirmative action requirements;
- (8) refuses to agree or abide with the bidder's labor agreement; or
- (9) is determined by the Contracting Officer to be nonresponsive."

Modify subject area "AWARD OF CONTRACT" as follows:

Subparagraph (a) substitute the word "generally" for the phrase "as soon as practical and"

Subparagraph (b) delete and substitute the following:

"All Bidders will be notified of the AUTHORITY's intent to Award the Contract and the successful Bidder will be requested to execute certain documents, including the Contract form and bonds."

## REQUIRED DOCUMENTS

**REQUIRED FOR BID.** Bids will not be considered if the following documents are not completely filled out and submitted at the time of bidding:

1. **Bid Form (Form 25D-9)**
  2. **Bid Schedule**
  3. **Bid Security**
  4. Any bid revisions must be submitted by the bidder prior to bid opening on the following form:  
**Bid Modification (Form 25D-16)**
- 

**REQUIRED AFTER NOTICE OF APPARENT LOW BIDDER.** The apparent low bidder is required to complete and submit the following document within 5 working days after receipt of written notification:

1. **Subcontractor List (Form 25D-5)**
- 

**REQUIRED FOR AWARD.** In order to be awarded the contract, the successful bidder must completely fill out and submit the following documents within the time specified in the intent to award letter:

1. **Construction Contract (Form 25D-10A)**
2. **Payment Bond (Form 25D-12)**
3. **Performance Bond (Form 25D-13)**
4. **Contractor's Questionnaire (Form 25D-8)**
5. **Certificate of Insurance** (from carrier)

**PROPOSAL**  
of

NAME \_\_\_\_\_

ADDRESS \_\_\_\_\_

\_\_\_\_\_

**To the CONTRACTING OFFICER, ALASKA ENERGY AUTHORITY:**

In compliance with your Invitation To Bid dated **November 2, 2016**, the Undersigned proposes to do all the work and labor required in the construction of Project:

**Project Name**

**Rural Power System Upgrade (RPSU)  
Electrical and Mechanical Installation  
On Behalf Of Kipnuk and Kake**

**Project No. 17047**

Located at **Anchorage, Alaska**, according to the plans and specifications and for the amount and prices named herein as indicated on the Bid Schedule consisting of **2** sheet(s), which is made a part of this Bid.

The Undersigned declares that he has carefully examined the contract requirements and that he has made a personal examination of the site of the work; that he understands that the quantities, where such are specified in the Bid Schedule or on the plans for this project, are approximate only and subject to increase or decrease, and that he is willing to perform increased or decreased quantities of work at unit prices bid under the conditions set forth in the Contract Documents.

The Undersigned hereby agrees to execute the said contract and bonds within fifteen calendar days, or such further time as may be allowed in writing by the Contracting Officer, after receiving notification of the acceptance of this proposal, and it is hereby mutually understood and agreed that in case the Undersigned does not, the accompanying bid guarantee shall be forfeited to the Alaska Energy Authority, as liquidated damages, and the said Contracting officer may proceed to award the contract to others.

The Undersigned agrees to commence the work within 10 calendar days after the effective date of Notice to Proceed and to complete the work by **June 15, 2017**, unless extended in writing by the Contracting Officer.

The Undersigned proposes to furnish Payment Bond in the amount of 100% (of the contract) and Performance Bond in the amount of 100% (of the contract), as surety conditioned for the full, complete and faithful performance of this contract.

The Undersigned acknowledges receipt of the following addenda to the drawings and/or specifications (give number and date of each).

Addendum Number	Date Issued	Addendum Number	Date Issued	Addendum Number	Date Issued

**NON-COLLUSION AFFIDAVIT**

The Undersigned declares, under penalty of perjury under the laws of the United States, that neither he nor the firm, association, or corporation of which he is a member, has, either directly or indirectly, entered into any agreement, participated in any collusion, or otherwise taken any action in restraint of free competitive bidding in connection with this bid.

The Undersigned has read the foregoing proposal and hereby agrees to the conditions stated therein by affixing his signature below:

\_\_\_\_\_  
Signature

\_\_\_\_\_  
Name and Title of Person Signing

\_\_\_\_\_  
Telephone Number

\_\_\_\_\_  
Fax Number

**BID SCHEDULE**

**Rural Power System Upgrade (RPSU)  
Electrical and Mechanical Installation  
On Behalf Of Kipnuk and Kake  
Project No. 17047**

Bidders Please Note: Before preparing this bid schedule, read carefully, "Information to Bidders", and the following:

The Bidder shall insert a fixed price in figures opposite each pay item that appears in the bid schedule to furnish all labor. No price is to be entered or tendered for any item not appearing in the bid schedule.

Work will be performed on an hourly unit basis with a not-to-exceed limit. Copies of timecards or daily logs will be required with all progress payments. The Contractor shall separately track time spent on the Kake and Kipnuk modules. The proposed labor rates will become the basis of the contract. Payment will be made based on actual hours expended. Progress payments may be requested by the Contractor as frequently as every two weeks.

Provide firm fixed hourly rates for each of the labor categories where indicated below. The hourly rates shall include the burdened hourly labor cost plus any Contractor's overhead and profit. The rate shall include the required project insurance and payment and performance bonding. Extend and total pricing as indicated. The estimated total cost for all labor listed below will be used to determine the apparent low bidder.

This is a Not-to-Exceed, Time and Materials contract. The quantity hours are an estimate and are not guaranteed..

Conditioned or qualified bids will be considered non-responsive.

**Kake Labor Rates**

<u>Item</u>	<u>Qty</u>	<u>Unit Cost</u>	<u>Ext Cost</u>
<u>Kake Foreman (straight time)</u>	<u>440 hr.</u>	<u>\$/hr</u>	<u>\$</u>
<u>Kake Foreman (overtime)</u>	<u>60 hr</u>	<u>\$/hr</u>	<u>\$</u>
<u>Kake Journeyman Electrician (straight time)</u>	<u>760 hr</u>	<u>\$/hr</u>	<u>\$</u>
<u>Kake Journeyman Electrician (overtime)</u>	<u>40 hr</u>	<u>\$/hr</u>	<u>\$</u>
<u>Kake Apprentice Electrician (straight time)</u>	<u>440 hr</u>	<u>\$/hr</u>	<u>\$</u>
<u>Kake Apprentice Electrician (overtime)</u>	<u>40 hr</u>	<u>\$/hr</u>	<u>\$</u>
<u>Kake Journeyman Welder (straight time)</u>	<u>440 hr</u>	<u>\$/hr</u>	<u>\$</u>
<u>Kake Journeyman Welder (overtime)</u>	<u>40 hr</u>	<u>\$/hr</u>	<u>\$</u>
<u>Kake Journeyman Fitter (straight time)</u>	<u>440 hr</u>	<u>\$/hr</u>	<u>\$</u>
<u>Kake Journeyman Fitter (overtime)</u>	<u>40 hr</u>	<u>\$/hr</u>	<u>\$</u>
<u>Kake Apprentice Fitter (straight time)</u>	<u>440 hr</u>	<u>\$/hr</u>	<u>\$</u>
<u>Kake Apprentice Fitter (overtime)</u>	<u>40 hr</u>	<u>\$/hr</u>	<u>\$</u>

**Kake Module Sub-Total** \$ \_\_\_\_\_

**Kipnuk Labor Rates**

<u>Item</u>	<u>Qty</u>	<u>Unit Cost</u>	<u>Ext Cost</u>
<u>Kipnuk Foreman (straight time)</u>	<u>400 hr.</u>	<u>\$/hr</u>	<u>\$</u>
<u>Kipnuk Foreman (overtime)</u>	<u>40 hr</u>	<u>\$/hr</u>	<u>\$</u>
<u>Kipnuk Journeyman Electrician (straight time)</u>	<u>760 hr</u>	<u>\$/hr</u>	<u>\$</u>
<u>Kipnuk Journeyman Electrician (overtime)</u>	<u>20 hr</u>	<u>\$/hr</u>	<u>\$</u>
<u>Kipnuk Apprentice Electrician (straight time)</u>	<u>400 hr</u>	<u>\$/hr</u>	<u>\$</u>
<u>Kipnuk Apprentice Electrician (overtime)</u>	<u>20 hr</u>	<u>\$/hr</u>	<u>\$</u>
<u>Kipnuk Journeyman Welder (straight time)</u>	<u>400 hr</u>	<u>\$/hr</u>	<u>\$</u>
<u>Kipnuk Journeyman Welder (overtime)</u>	<u>20 hr</u>	<u>\$/hr</u>	<u>\$</u>
<u>Kipnuk Journeyman Fitter (straight time)</u>	<u>400 hr</u>	<u>\$/hr</u>	<u>\$</u>
<u>Kipnuk Journeyman Fitter (overtime)</u>	<u>20 hr</u>	<u>\$/hr</u>	<u>\$</u>
<u>Kipnuk Apprentice Fitter (straight time)</u>	<u>400 hr</u>	<u>\$/hr</u>	<u>\$</u>
<u>Kipnuk Apprentice Fitter (overtime)</u>	<u>20 hr</u>	<u>\$/hr</u>	<u>\$</u>

**Kipnuk Module Sub-Total** \$ \_\_\_\_\_

**GRAND TOTAL** \$ \_\_\_\_\_

\_\_\_\_\_  
Contractor's Name (Printed)

\_\_\_\_\_  
Alaska Contractor's Registration # Expires

\_\_\_\_\_  
Alaska Business License # Expires



ALASKA ENERGY AUTHORITY

**BID BOND**

For

**Rural Power System Upgrade (RPSU)  
Electrical and Mechanical Installation  
On Behalf Of Kipnuk and Kake**

DATE BOND EXECUTED: \_\_\_\_\_

PRINCIPAL (Legal name and business address):

TYPE OF ORGANIZATION:

	<input type="checkbox"/> Individual	<input type="checkbox"/> Partnership
	<input type="checkbox"/> Joint Venture	<input type="checkbox"/> Corporation
STATE OF INCORPORATION:		

SURETY(IES) (Name and business address):

<b>A.</b>	<b>B.</b>	<b>C.</b>
PENAL SUM OF BOND:		DATE OF BID:

We, the PRINCIPAL and SURETY above named, are held and firmly bound to the State (State of Alaska), in the penal sum of the amount stated above, for the payment of which sum will be made, we bind ourselves and our legal representatives and successors, jointly and severally, by this instrument.

THE CONDITION OF THE FOREGOING OBLIGATION is that the Principal has submitted the accompanying bid in writing, date as shown above, on the above-referenced Project in accordance with contract documents filed in the office of the Contracting Officer, and under the Invitation To Bid therefore, and is required to furnish a bond in the amount stated above.

If the Principal's bid is accepted and he is offered the proposed contract for award, and if the Principal fails to enter into the contract, then the obligation to the State created by this bond shall be in full force and effect.

If the Principal enters into the contract, then the foregoing obligation is null and void.

**PRINCIPAL**

Signature(s)	1.	2.	3.
Name(s) & Title(s) (Typed)	1.	2.	3.

Corporate Seal

See Instructions on Reverse

**CORPORATE SURETY(IES)**

<b>Surety A</b>	Name of Corporation	State of Incorporation	Liability Limit \$
Signature(s)	1.	2.	Corporate Seal
Name(s) & Titles (Typed)	1.	2.	

<b>Surety B</b>	Name of Corporation	State of Incorporation	Liability Limit \$
Signature(s)	1.	2.	Corporate Seal
Name(s) & Titles (Typed)	1.	2.	

<b>Surety C</b>	Name of Corporation	State of Incorporation	Liability Limit \$
Signature(s)	1.	2.	Corporate Seal
Name(s) & Titles (Typed)	1.	2.	

**INSTRUCTIONS**

1. This form shall be used whenever a bid bond is submitted.
2. Insert the full legal name and business address of the Principal in the space designated. If the Principal is a partnership or joint venture, the names of all principal parties must be included (e.g., "Smith Construction, Inc. and Jones Contracting, Inc. DBA Smith/Jones Builders, a joint venture"). If the Principal is a corporation, the name of the state in which incorporated shall be inserted in the space provided.
3. Insert the full legal name and business address of the Surety in the space designated. The Surety on the bond may be any corporation or partnership authorized to do business in Alaska as an insurer under AS 21.09. Individual sureties will not be accepted.
4. The penal amount of the bond may be shown either as an amount (in words and figures) or as a percent of the contract bid price (a not-to-exceed amount may be included).
5. The scheduled bid opening date shall be entered in the space marked Date of Bid.
6. The bond shall be executed by authorized representatives of the Principal and Surety. Corporations executing the bond shall also affix their corporate seal.
7. Any person signing in a representative capacity (e.g., an attorney-in-fact) must furnish evidence of authority if that representative is not a member of the firm, partnership, or joint venture, or an officer of the corporation involved.
8. The states of incorporation and the limits of liability of each surety shall be indicated in the spaces provided.
9. The date that bond is executed must not be later than the bid opening date.

**BID MODIFICATION**

**Rural Power System Upgrade (RPSU)  
Electrical and Mechanical Installation  
On Behalf Of Kipnuk and Kake**

Modification Number: \_\_\_\_\_

Note: All revisions shall be made to the unadjusted bid amount(s).  
Changes to the adjusted bid amounts will be computed by the Authority.

<b>PAY ITEM NO.</b>	<b>PAY ITEM DESCRIPTION</b>	<b>REVISION TO UNIT BID PRICE +/-</b>	<b>REVISION TO BID AMOUNT +/-</b>

**TOTAL REVISION: \$** \_\_\_\_\_

\_\_\_\_\_ **Name of Bidding Firm**

\_\_\_\_\_ **Responsible Party Signature** **Date**

This form may be duplicated if additional pages are needed.

ALASKA ENERGY AUTHORITY

**SUBCONTRACTOR LIST**  
**Rural Power System Upgrade (RPSU)**  
**Electrical and Mechanical Installation**  
**On Behalf Of Kipnuk and Kake**

The apparent low bidder shall complete this form and submit it so as to be received by the Contracting Officer prior to the close of business on the fifth working day after receipt of written notice from the Authority.

Failure to submit this form with all required information by the due date will result in the bidder being declared nonresponsive and may result in the forfeiture of the Bid Security.

Scope of work must be clearly defined. If an item of work is to be performed by more than one firm, indicate the portion or percent of work to be done by each.

**Check as applicable:**       All Work on the above-referenced project will be accomplished without subcontracts greater than ½ of 1% of the contract amount.

**or** Subcontractor List is as follows:

LIST FIRST TIER SUBCONTRACTORS ONLY

FIRM NAME, ADDRESS, PHONE NO.	AK BUSINESS LICENSE NO., CONTRACTOR'S REGISTRATION NO.	SCOPE OF WORK TO BE PERFORMED

CONTINUE SUBCONTRACTOR INFORMATION ON REVERSE

**For projects with federal-aid funding, I hereby certify Alaska Business Licenses and Contractor's Registrations will be valid for all subcontractors prior to award of the subcontract. For projects without federal-aid funding (State funding only), I hereby certify the listed Alaska Business Licenses and Contractor's Registrations were valid at the time bids were opened for this project.**

\_\_\_\_\_  
Signature of Authorized Company Representative

\_\_\_\_\_  
Title

\_\_\_\_\_  
Company Name

\_\_\_\_\_  
Company Address (Street or PO Box, City, State, Zip)

\_\_\_\_\_  
Date

(    )  
\_\_\_\_\_  
Phone Number

FIRM NAME, ADDRESS, PHONE NO.	AK BUSINESS LICENSE NO., CONTRACTOR'S REGISTRATION NO.	SCOPE OF WORK TO BE PERFORMED

## CONSTRUCTION CONTRACT

### Rural Power System Upgrade (RPSU) Electrical and Mechanical Installation On Behalf Of Kipnuk and Kake

This CONTRACT, between the ALASKA ENERGY AUTHORITY, herein called the Authority, acting by and through its Contracting Officer, and

\_\_\_\_\_  
**Company Name**

\_\_\_\_\_  
**Company Address (Street or PO Box, City, State, Zip)**

a/an  Individual  Partnership  Joint Venture  Sole Proprietorship  Corporation incorporated under the laws of the State of \_\_\_\_\_, its successors and assigns, herein called the Contractor, is effective the date of the signature of the Contracting Officer on this document.

WITNESSETH: That the Contractor, for and in consideration of the payment or payments herein specified and agreed to by the Authority, hereby covenants and agrees to perform all the work and labor required in the construction of the above-referenced project at the prices bid by the Contractor for the respective estimated quantities aggregating approximately the sum of

\_\_\_\_\_ Dollars  
(\$ \_\_\_\_\_), and such other items as are mentioned in the original Bid, which Bid and prices named, together with the Contract Documents are made a part of this Contract and accepted as such.

It is distinctly understood and agreed that no claim for additional work or materials, done or furnished by the Contractor and not specifically herein provided for, will be allowed by the Authority, nor shall the Contractor do any work or furnish any material not covered by this Contract, unless such work is ordered in writing by the Authority. In no event shall the Authority be liable for any materials furnished or used, or for any work or labor done, unless the materials, work, or labor are required by the Contract or on written order furnished by the Authority. Any such work or materials which may be done or furnished by the Contractor without written order first being given shall be at the Contractor's own risk, cost, and expense and the Contractor hereby covenants and agrees to make no claim for compensation for work or materials done or furnished without such written order.

The Contractor further covenants and agrees that all labor shall be done and performed, in every respect, to the satisfaction of the Authority, on or before: \_\_\_\_\_ or within \_\_\_\_\_ calendar days. It is expressly understood and agreed that in case of the failure on the part of the Contractor, for any reason, except with the written consent of the Authority, performance of the work before the aforesaid date, the Authority shall have the right to deduct from any money due or which may become due the Contractor, or if no money shall be due, the Authority shall have the right to recover \_\_\_\_\_ Dollars (\$ \_\_\_\_\_) per day for each calendar day elapsing between the time stipulated for the completion and the actual date of completion in accordance with the terms hereof; such deduction to be made, or sum to be recovered, not as a penalty but as liquidated damages.

The bonds given by the Contractor in the sum of \$ \_\_\_\_\_ Payment Bond, and \$ \_\_\_\_\_ Performance Bond, to secure the proper compliance with the terms and provisions of this Contract, are submitted herewith and made a part hereof.

IN WITNESS WHEREOF, the parties hereto have executed this Contract and hereby agree to its terms and conditions.

---

**CONTRACTOR**

---

**Company Name**

---

**Signature of Authorized Company Representative**

---

**Typed Name and Title**

---

**Date**

(Corporate Seal)

---

**ALASKA ENERGY AUTHORITY**

---

**Signature of Contracting Officer**

---

**Typed Name**

---

**Date**

ALASKA ENERGY AUTHORITY

**PERFORMANCE BOND**

Bond No. \_\_\_\_\_

For  
**Rural Power System Upgrade (RPSU)  
Electrical and Mechanical Installation  
On Behalf Of Kipnuk and Kake**

KNOW ALL WHO SHALL SEE THESE PRESENTS:

That \_\_\_\_\_  
of \_\_\_\_\_ as Principal,  
and \_\_\_\_\_  
of \_\_\_\_\_ as Surety,  
firmly bound and held unto the State of Alaska in the penal sum of \_\_\_\_\_ Dollars

( \$ \_\_\_\_\_ ) good and lawful money of the United States of America for the payment whereof,  
well and truly to be paid to the State of Alaska, we bind ourselves, our heirs, successors, executors, administrators, and assigns,  
jointly and severally, firmly by these presents.

WHEREAS, the said Principal has entered into a written contract with said State of Alaska, on the \_\_\_\_\_ of \_\_\_\_\_  
A.D., 20\_\_\_\_, for construction of the above-named project, said work to be done according to the terms of said contract.

Now, THEREFORE, the conditions of the foregoing obligation are such that if the said Principal shall well and truly perform and  
complete all obligations and work under said contract and if the Principal shall reimburse upon demand of the Alaska Energy  
Authority any sums paid him which exceed the final payment determined to be due upon completion of the project, then these  
presents shall become null and void; otherwise they shall remain in full force and effect.

IN WITNESS WHEREOF, we have hereunto set our hands and seals at \_\_\_\_\_,  
\_\_\_\_\_ this \_\_\_\_\_ day of \_\_\_\_\_ A.D., 20\_\_\_\_.

**Principal:** \_\_\_\_\_

**Address:** \_\_\_\_\_

**By:** \_\_\_\_\_

**Contact Name:** \_\_\_\_\_

**Phone:** (    ) \_\_\_\_\_

**Surety:** \_\_\_\_\_

**Address:** \_\_\_\_\_

**By:** \_\_\_\_\_

**Contact Name:** \_\_\_\_\_

**Phone:** (    ) \_\_\_\_\_

The offered bond has been checked for adequacy under the applicable statutes and regulations:

\_\_\_\_\_  
**Alaska Energy Authority Authorized Representative**

\_\_\_\_\_  
**Date**

See Instructions on Reverse



## INSTRUCTIONS

1. This form shall be used whenever a performance bond is required. There shall be no deviation from this form without approval from the Contracting Officer.
2. The full legal name, business address, phone number, and point of contact of the Principal and Surety shall be typed on the face of the form. Where more than a single surety is involved, a separate form shall be executed for each surety.
3. The penal amount of the bond, or in the case of more than one surety the amount of obligation, shall be typed in words and in figures.
4. Where individual sureties are involved, a completed Affidavit of Individual Surety shall accompany the bond. Such forms are available upon request from the Contracting Officer.
5. The bond shall be signed by authorized persons. Where such person is signing in a representative capacity (e.g., an attorney-in-fact), but is not a member of the firm, partnership, or joint venture, or an officer of the corporation involved, evidence of authority must be furnished.

ALASKA ENERGY AUTHORITY

**PAYMENT BOND**

Bond No. \_\_\_\_\_

For

**Rural Power System Upgrade (RPSU)  
Electrical and Mechanical Installation  
On Behalf Of Kipnuk and Kake**

NOW ALL WHO SHALL SEE THESE PRESENTS:

That \_\_\_\_\_  
of \_\_\_\_\_ as Principal,  
and \_\_\_\_\_  
of \_\_\_\_\_ as Surety,  
firmly bound and held unto the State of Alaska in the penal sum of \_\_\_\_\_ Dollars

( \$ \_\_\_\_\_ ) good and lawful money of the United States of America for the payment whereof, well and truly to be paid to the State of Alaska, we bind ourselves, our heirs, successors, executors, administrators, and assigns, jointly and severally, firmly by these presents.

WHEREAS, the said Principal has entered into a written contract with said State of Alaska, on the \_\_\_\_\_ of \_\_\_\_\_ A.D., 20\_\_\_\_, for construction of the above-referenced project, said work to be done according to the terms of said contract.

Now, THEREFORE, the conditions of the foregoing obligation are such that if the said Principal shall comply with all requirements of law and pay, as they become due, all just claims for labor performed and materials and supplies furnished upon or for the work under said contract, whether said labor be performed and said materials and supplies be furnished under the original contract, any subcontract, or any and all duly authorized modifications thereto, then these presents shall become null and void; otherwise they shall remain in full force and effect.

IN WITNESS WHEREOF, we have hereunto set our hands and seals at \_\_\_\_\_, \_\_\_\_\_ this \_\_\_\_\_ day of \_\_\_\_\_ A.D., 20\_\_\_\_.

**Principal:** \_\_\_\_\_

**Address:** \_\_\_\_\_

**By:** \_\_\_\_\_

**Contact Name:** \_\_\_\_\_

**Phone:** (    ) \_\_\_\_\_

**Surety:** \_\_\_\_\_

**Address:** \_\_\_\_\_

**By:** \_\_\_\_\_

**Contact Name:** \_\_\_\_\_

**Phone:** (    ) \_\_\_\_\_

The offered bond has been checked for adequacy under the applicable statutes and regulations:

\_\_\_\_\_  
Alaska Energy Authority Authorized Representative

\_\_\_\_\_  
Date

See Instructions on Reverse

## **INSTRUCTIONS**

1. This form, for the protection of persons supplying labor and material, shall be used whenever a payment bond is required. There shall be no deviation from this form without approval from the Contracting Officer.
2. The full legal name, business address, phone number, and point of contact of the Principal and Surety shall be typed on the face of the form. Where more than a single surety is involved, a separate form shall be executed for each surety.
3. The penal amount of the bond, or in the case of more than one surety the amount of obligation, shall be typed in words and in figures.
4. Where individual sureties are involved, a completed Affidavit of Individual Surety shall accompany the bond. Such forms are available upon request from the Contracting Officer.
5. The bond shall be signed by authorized persons. Where such persons are signing in a representative capacity (e.g., an attorney-in-fact), but is not a member of the firm, partnership, or joint venture, or an officer of the corporation involved, evidence of authority must be furnished.

## CONTRACTOR'S QUESTIONNAIRE

### Rural Power System Upgrade (RPSU) Electrical and Mechanical Installation On Behalf Of Kipnuk and Kake

**A. FINANCIAL**

1. Have you ever failed to complete a contract due to insufficient resources?  
 No  Yes If YES, explain:

---

---

---

---

2. Describe any arrangements you have made to finance this work: \_\_\_\_\_

---

---

**B. EQUIPMENT**

1. Describe below the equipment you have available and intend to use for this project.

ITEM	QUAN.	MAKE	MODEL	SIZE/ CAPACITY	PRESENT MARKET VALUE

2. What percent of the total value of this contract do you intend to subcontract? \_\_\_\_\_ %

3. Do you propose to purchase any equipment for use on this project?  
[ ] No [ ] Yes If YES, describe type, quantity, and approximate cost:

---

---

---

4. Do you propose to rent any equipment for this work?  
[ ] No [ ] Yes If YES, describe type and quantity:

---

---

---

5. Is your bid based on firm offers for all materials necessary for this project?  
[ ] Yes [ ] No If NO, please explain:

---

---

---

**C. EXPERIENCE**

1. Have you had previous construction contracts or subcontracts with the Authority?  
[ ] Yes [ ] No

Describe the most recent or current contract, its completion date, and scope of work:

---

---

---

---

2. List, as an attachment to this questionnaire, other construction projects you have completed, the dates of completion, scope of work, and total contract amount for each project completed in the past 12 months.

**I hereby certify that the above statements are true and complete.**

\_\_\_\_\_  
**Name of Contractor**

\_\_\_\_\_  
**Name and Title of Person Signing**

\_\_\_\_\_  
**Signature**

\_\_\_\_\_  
**Date**

**ALASKA ENERGY AUTHORITY  
SECTION 00700  
GENERAL CONDITIONS**

- ARTICLE 1    DEFINITIONS
  
- ARTICLE 2    AUTHORIZATION AND LIMITATIONS
  - 2.1    Authorities and Limitations
  - 2.2    Evaluations by Contracting Officer
  - 2.3    Means and Methods
  - 2.4    Visits to Site
  
- ARTICLE 3    CONTRACT DOCUMENTS: INTENT, AMENDING, REUSE
  - 3.1    Incomplete Contract Documents
  - 3.2    Copies of Contract Documents
  - 3.3    Scope of Work
  - 3.4    Intent of Contract Documents
  - 3.5    Discrepancy in Contract Documents
  - 3.6    Clarifications and Interpretations
  - 3.7    Reuse of Documents
  
- ARTICLE 4    LANDS AND PHYSICAL CONDITIONS
  - 4.1    Availability of Lands
  - 4.2    Visit to Site
  - 4.3    Explorations and Reports
  - 4.4    Utilities
  - 4.5    Damaged Utilities
  - 4.6    Utilities Not Shown or Indicated
  - 4.7    Survey Control
  
- ARTICLE 5    BONDS AND INSURANCE, AND INDEMNIFICATION
  - 5.1    Delivery of Bonds
  - 5.2    Bonds
  - 5.3    Replacement of Bond and Surety
  - 5.4    Insurance Requirements
  - 5.5    Indemnification
  
- ARTICLE 6    CONTRACTOR'S RESPONSIBILITIES
  - 6.1    Supervision of Work
  - 6.2    Superintendence by CONTRACTOR
  - 6.3    Character of Workers
  - 6.4    CONTRACTOR to Furnish
  - 6.5    Materials and Equipment
  - 6.6    Anticipated Schedules
  - 6.7    Finalizing Schedules
  - 6.8    Adjusting Schedules
  - 6.9    Substitutes or "Or-Equal" Items
  - 6.10    Substitute Means and Methods
  - 6.11    Evaluation of Substitution
  - 6.12    Dividing the Work
  - 6.13    Subcontractors

- 6.14 Use of Premises
  - 6.15 Structural Loading
  - 6.16 Record Documents
  - 6.17 Safety and Protection
  - 6.18 Safety Representative
  - 6.19 Emergencies
  - 6.20 Shop Drawings and Samples
  - 6.21 Shop Drawing and Sample Review
  - 6.22 Maintenance during Construction
  - 6.23 Continuing the Work
  - 6.24 Consent to Assignment
  - 6.25 Use of Explosives
  - 6.26 CONTRACTOR's Records
  - 6.27 Load Restrictions
- ARTICLE 7 LAWS AND REGULATIONS
- 7.1 Laws to be observed
  - 7.2 Permits, Licenses, and Taxes
  - 7.3 Patented Devices, Materials and Processes
  - 7.4 Compliance of Specifications and Drawings
  - 7.5 Accident Prevention
  - 7.6 Sanitary Provisions
  - 7.7 Business Registration
  - 7.8 Professional Registration and Certification
  - 7.9 Local Building Codes
  - 7.10 Air Quality Control
  - 7.11 Archaeological or Paleontological Discoveries
  - 7.12 Applicable Alaska Preferences
  - 7.13 Preferential Employment
  - 7.14 Wages and Hours of Labor
  - 7.15 Overtime Work Hours and Compensation
  - 7.16 Covenants against Contingent Fees
  - 7.17 Officials Not to Benefit
  - 7.18 Personal Liability of Public Officials
- ARTICLE 8 OTHER WORK
- 8.1 Related Work at Site
  - 8.2 Access, Cutting, and Patching
  - 8.3 Defective Work by Others
  - 8.4 Coordination
- ARTICLE 9 CHANGES
- 9.1 AUTHORITY's Right to Change
  - 9.2 Authorization of Changes within the General Scope
  - 9.3 Directive
  - 9.4 Change Order
  - 9.5 Shop Drawing Variations
  - 9.6 Changes outside the General Scope; Supplemental Agreement
  - 9.7 Unauthorized Work
  - 9.8 Notification of Surety
  - 9.9 Differing Site Conditions

9.10 Interim Work Authorization

ARTICLE 10 CONTRACT PRICE; COMPUTATION AND CHANGE

- 10.1 Contract Price
- 10.2 Claims for Price Change
- 10.3 Change Order Price Determination
- 10.4 Cost of the Work
- 10.5 Excluded Costs
- 10.6 CONTRACTOR's Fee
- 10.7 Cost Breakdown
- 10.8 Cash Allowances
- 10.9 Unit Price Work
- 10.10 Determinations for Unit Prices

ARTICLE 11 CONTRACT TIME, COMPUTATION AND CHANGE

- 11.1 Commencement of Contract Time; Notice to Proceed
- 11.2 Starting the Work
- 11.3 Computation of Contract Time
- 11.4 Time Change
- 11.5 Extension Due to Delays
- 11.6 Essence of Contract
- 11.7 Reasonable Completion Time
- 11.8 Delay Damages

ARTICLE 12 QUALITY ASSURANCE

- 12.1 Warranty and Guaranty
- 12.2 Access to Work
- 12.3 Tests and Inspections
- 12.4 Uncovering Work
- 12.5 AUTHORITY May Stop the Work
- 12.6 Correction or Removal of Defective Work
- 12.7 One Year Correction Period
- 12.8 Acceptance of Defective Work
- 12.9 AUTHORITY may Correct Defective Work

ARTICLE 13 PAYMENTS TO CONTRACTOR AND COMPLETION

- 13.1 Schedule of Values
- 13.2 Preliminary Payments
- 13.3 Application for Progress Payment
- 13.4 Review of Applications for Progress Payments
- 13.5 Stored Materials and Equipment
- 13.6 CONTRACTOR's Warranty of Title
- 13.7 Withholding of Payments
- 13.8 Retainage
- 13.9 Request for Release of funds
- 13.10 Substantial Completion
- 13.11 Access Following Substantial Completion
- 13.12 Final Inspection
- 13.13 Final Completion and Application for Payment
- 13.14 Final Payment



- 13.15 Final Acceptance
- 13.16 CONTRACTOR's Continuing Obligation
- 13.17 Waiver of Claims by CONTRACTOR
- 13.18 No Waiver of Legal Rights

ARTICLE 14 SUSPENSION OF WORK AND TERMINATION

- 14.1 AUTHORITY May Suspend Work
- 14.2 Default of Contract
- 14.3 Rights or Remedies
- 14.4 Convenience Termination

ARTICLE 15 CLAIMS AND DISPUTES

- 15.1 Notification
- 15.2 Presenting Claim
- 15.3 Claim Validity, Additional Information & Authority's Action
- 15.4 Contracting Officer's Decision
- 15.5 Appeals on a Contract Claim
- 15.6 Construction Contract Claim Appeal
- 15.7 Fraud and Misrepresentation in Making a Claim

## **ARTICLE 1 - DEFINITIONS**

Wherever used in the Contract Documents the following terms, or pronouns in place of them, are used, the intent and meaning, unless a different intent or meaning is clearly indicated, shall be interpreted as set forth below.

The titles and headings of the articles, sections, and subsections herein are intended for convenience of reference.

Terms not defined below shall have their ordinary accepted meanings within the context which they are used. Words which have a well-known technical or trade meaning when used to describe work, materials or equipment shall be interpreted in accordance with such meaning. Words defined in Article 1 are to be interpreted as defined.

**Addenda** - All clarifications, corrections, or changes issued graphically or in writing by the AUTHORITY after the Advertisement but prior to the opening of Proposals.

**Advertisement** - The public announcement, as required by law, inviting bids for Work to be performed or materials to be furnished.

**Application for Payment** - The form provided by the AUTHORITY which is to be used by the CONTRACTOR in requesting progress or final payments and which is to include such supporting documentation as is required by the Contract Documents.

**Approved or Approval** - Means written approval by the Contracting Officer or his authorized representative as defined in Article 2.1. 'Approved' or 'Approval' as used in this contract document shall mean that the Authority has received a document, form or submittal from the Contractor and that the Authority has taken "No exceptions" to the item submitted. Unless the context clearly indicates otherwise, approved or approval shall not mean that the Authority approves of the methods or means, or that the item or form submitted meets the requirements of the contract or constitutes acceptance of the Contractor's work. Where approved or approval means acceptance, then such approval must be set forth in writing and signed by the contracting officer or his designee.

**A.S** - Initials which stand for Alaska Statute.

**Authority** - The Alaska Energy Authority (AEA). References to "Contracting Agency" means the AUTHORITY. The AUTHORITY is acting as an agent for Owner.

**Award** - The acceptance, by the AUTHORITY, of the successful bid.

**Bid Bond** - A type of Proposal Guaranty.

**Bidder** - Any individual, firm, corporation or any acceptable combination thereof, or joint venture submitting a bid for the advertised Work.

**Calendar Day** - Every day shown on the calendar, beginning and ending at midnight.

**Change Order** - A written order by the AUTHORITY directing changes to the Contract Documents, within their general scope.

**Consultant** - The person, firm, or corporation retained directly by the AUTHORITY to prepare Contract Documents, perform construction administration services, or other Project related services. References to Authority's Consultants shall include Engineer.

**Contingent Sum Work Item** - When the bid schedule contains a Contingent Sum Work Item, the Work covered shall be performed only upon the written Directive of the Project Manager. Payment shall be made as provided in the Directive.

**Contract** - The written agreement between the AUTHORITY and the CONTRACTOR setting forth the obligations of the parties and covering the Work to be performed, all as required by the Contract Documents.

**Contract Documents** - The Contract form, Addenda, the bidding requirements and CONTRACTOR's bid (including all appropriate bid tender forms), the bonds, the Conditions of the Contract and all other Contract requirements, the Specifications, and the Drawings furnished by the AUTHORITY to the CONTRACTOR, together with all Change Orders and documents approved by the Contracting Officer, for inclusion, modifications and supplements issued on or after the Effective Date of the Contract.

**Contracting Officer** - The person authorized by the Executive Director to enter into and administer the Contract on behalf of the AUTHORITY; who has authority to make findings, determinations and decisions with respect to the Contract and, when necessary, to modify or terminate the Contract. The Contracting Officer is identified on the construction Contract.

**Contractor** - The individual, firm, corporation or any acceptable combination thereof, contracts with the AUTHORITY for performance of the Work.

**Contract Price** - The total moneys payable by the AUTHORITY to the CONTRACTOR under the terms of the Contract Documents.

**CONTRACTOR's Release** – CONTRACTOR's written notification to the AUTHORITY specifying final payment due and releasing the AUTHORITY of any and all claims.

**Contract Time** - The number of Calendar Days following issuance of Notice-to-Proceed in which the project shall be rendered Substantially Complete, or if specified as a calendar date, the Substantial Completion date specified in the Contract Documents.

**Controlling Item** - Any feature of the Work on the critical path of a network schedule.

**Defective** - Work that is unsatisfactory, faulty or deficient, or does not conform to the Contract Documents.

**Directive** - A written communication to the CONTRACTOR from the Contracting Officer interpreting or enforcing a Contract requirement or ordering commencement of an item of Work.

**Drawings** - The Drawings which show the character and scope of the Work to be performed and which have been furnished by the AUTHORITY and are by reference made a part of the Contract Documents.

**Engineer** - The person, firm, or corporation retained directly by the AUTHORITY to prepare Contract Documents, perform construction administration services, or other Project related services.

**Equipment** - All machinery together with the necessary supplies for upkeep and maintenance, and also tools and apparatus necessary for the proper construction and acceptable completion of the work.

**Final Completion** - The Project has progressed to the point that all required Work is complete..

**Furnish** - To procure, transport, and deliver to the project site materials, labor, or equipment, for installation or use on the project.

**General Requirements** - Sections of Division I of the Specifications which contain administrative and procedural requirements as well as requirements for temporary facilities which apply to Specification Divisions 2 through I6.

**Holidays** - In the State of Alaska, Legal Holidays occur on:

1. New Years Day - January 1
2. Martin Luther King's Birthday - Third Monday in January
3. President's Day - Third Monday in February
4. Seward's Day - Last Monday in March
5. Memorial Day - Last Monday in May
6. Independence Day - July 4
7. Labor Day - First Monday in September
8. Alaska Day - October 18
9. Veteran's Day - November 11
10. Thanksgiving Day - Fourth Thursday in November
11. Christmas Day - December 25
12. Every Sunday
13. Every day designated by public proclamation by the President of the United States or the Governor of the State as a legal Holiday.

If any Holiday listed above falls on a Saturday, Saturday and the preceding Friday are both legal Holidays. If the Holiday should fall on a Sunday, except (12) above, Sunday and the following Monday are both legal Holidays. See Title 44, Alaska Statutes.

**Install** - Means to build into the Work, ready to be used in complete and operable condition and in compliance with Contract Documents.

**Interim Work Authorization** - A written order by the Project Manager initiating changes to the Contract within its general scope, until a subsequent Change Order is executed.

**Invitation for Bids** - A portion of the bidding documents soliciting bids for the Work to be performed.

**Materials** - Any substances specified for use in the construction of the project.

**Notice of Intent to Award** - The written notice by the AUTHORITY to all Bidders identifying the apparent successful Bidder and establishing the AUTHORITY's intent to execute the Contract when all conditions required for execution of the Contract are met.

**Notice to Proceed** - A written notice to the CONTRACTOR to begin the Work and establishing the date on which the Contract Time begins.

**Onsite Project Representative** - The Engineer's authorized representative assigned to make detailed observations relating to contract performance.

**Owner** – Means Grantee for whom the ALASKA ENERGY AUTHORITY is acting as an agent of.

**Payment Bond** - The security furnished by the CONTRACTOR and his Surety to guarantee payment of the debts covered by the bond.

**Performance Bond** - The security furnished by the CONTRACTOR and his Surety to guarantee performance and completion of the Work in accordance with the Contract.

**Pre-construction Conference** - A meeting between the CONTRACTOR, Project Manager and the Engineer, and other parties affected by the construction, to discuss the project before the CONTRACTOR begins work.

**Project Manager** - The authorized representative of the Contracting Officer who is responsible for administration of the Contract.

**Procurement Manager/Officer** - The person authorized by the Contracting Officer to administer the Contract on behalf of the AUTHORITY; who has authority to make findings, determinations and decisions with respect to the Contract and, when necessary present such to the Contracting Officer, to modify or terminate the Contract.

**Project** - The total construction, of which the Work performed under the Contract Documents, is the whole or a part, where such total construction may be performed by more than one CONTRACTOR.

**Proposal** - The offer of a Bidder, on the prescribed forms, to perform the Work at the prices quoted.

**Proposal Guaranty** - The security furnished with a Proposal to guarantee that the bidder will enter into a Contract if his Proposal is accepted by the AUTHORITY.

**Quality Assurance (QA)** - Where referred to in the technical specifications (Divisions 2 through 16), Quality Assurance refers to measures to be provided by the CONTRACTOR as specified.

**Quality Control (QC)** - Tests and inspections by the CONTRACTOR to insure the acceptability of materials incorporated into the work. QC test reports are used as a basis upon which to determine whether the Work conforms to the requirements of the Contract Documents and to determine its acceptability for payment.

**Regulatory Requirements** - Laws, rules, regulations, ordinances, codes and/or orders.

**Schedule of Values** - Document submitted by the CONTRACTOR and reviewed by the Contracting Officer, which shall serve as the basis for computing payment and for establishing the value of separate items of Work which comprise the Contract Price.

**Shop Drawings** - All drawings, diagrams, illustrations, schedules and other data which are specifically prepared by or for the CONTRACTOR to illustrate some portion of the Work and all illustrations, brochures, standard schedules, performance charts, instructions, diagrams and other information prepared by a Supplier and submitted by the CONTRACTOR to illustrate

material, equipment, fabrication, or erection for some portion of the Work. Where used in the Contract Documents, "Shop Drawings" shall also mean "Submittals".

**Specifications** - Those portions of the Contract Documents consisting of written technical descriptions of materials, equipment, construction systems, standards and workmanship as applied to the Work and certain administrative and procedural details applicable thereto.

**Subcontractor** - An individual, firm, or corporation to whom the CONTRACTOR or any other Subcontractor sublets part of the Contract.

**Substantial Completion** - Although not fully completed, the Work (or a specified part thereof) has progressed to the point where it is sufficiently complete, in accordance with the Contract Documents, so that the Work (or specified part) can be utilized for the purposes for which it is intended. The terms "Substantially Complete" and "Substantially Completed" as applied to any Work refer to Substantial Completion thereof.

**Supplemental Agreement** - A written agreement between the CONTRACTOR and the AUTHORITY covering work that is not within the general scope of the Contract.

**Supplementary Conditions** - The part of the Contract Documents which amends or supplements these General Conditions.

**Supplier** - A manufacturer, fabricator, distributor, material man, or vendor of materials or equipment.

**Surety** - The corporation, partnership, or individual, other than the CONTRACTOR, executing a bond furnished by the CONTRACTOR.

**Unit Price Work** - Work to be paid for on the basis of unit prices.

**Utility** - The privately, publicly or cooperatively owned lines, facilities and systems for producing, transmitting or distributing communications, power, electricity, light, heat, gas, oil, crude products, water, steam, waste, storm water not connected with highway or street drainage, and other similar commodities, including publicly owned fire and police signal systems, street lighting systems, and railroads which directly or indirectly serve the public or any part thereof. The term "utility" shall also mean the utility company, inclusive of any wholly owned or controlled subsidiary."

**Work** - Work is the act of, and the result of, performing services, furnishing labor, furnishing and incorporating materials and equipment into the Project and performing other duties and obligations, all as required by the Contract Documents. Such Work, however incremental, will culminate in the entire completed Project, or the various separately identifiable parts thereof.

## **ARTICLE 2 – AUTHORIZATION AND LIMITATIONS**

### **2.1 Authorities and Limitations**

- 2.1.1 The Contracting Officer alone shall have the power to bind the AUTHORITY and to exercise the rights, responsibilities, authorities and functions vested in the Contracting Officer by the Contract Documents. The Contracting Officer shall have the right to designate in writing authorized representatives to act for him. Wherever any provision of the Contract Documents specifies an individual or organization, whether governmental or private, to perform any act on behalf of or in the interest of the AUTHORITY that individual or organization shall be deemed to be the Contracting Officer's authorized representative under this Contract but only to the extent so specified.
- 2.1.2 The CONTRACTOR shall perform the Work in accordance with any written order (including but not limited to instruction, direction, interpretation or determination) issued by an authorized representative in accordance with the authorized representative's authority to act for the Contracting Officer. The CONTRACTOR assumes all the risk and consequences of performing the Work in accordance with any order (including but not limited to instruction, direction, interpretation or determination) of anyone not authorized to issue such order, and of any order not in writing.
- 2.1.3 The performance or nonperformance of the Contracting Officer or his authorized representative, shall not give rise to any contractual obligation or duty to the CONTRACTOR, any Subcontractor, any Supplier, or any other organization performing any of the Work or any Surety representing them.

### **2.2 Evaluations by Contracting Officer:**

- 2.2.1 The Contracting Officer or his authorized representative will decide all questions which may arise as to:
- a. Quality and acceptability of materials furnished;
  - b. Quality and acceptability of Work performed;
  - c. Compliance with the schedule of progress;
  - d. Interpretation of Contract Documents;
  - e. Acceptable fulfillment of the Contract on the part of the CONTRACTOR.
- 2.2.2 In order to avoid cumbersome terms and confusing repetition of expressions in the Contract Documents the terms "as ordered", "as directed", "as required", "as approved" or terms of like effect or import are used, or the adjectives "reasonable", "suitable", "acceptable", "proper" or "satisfactory" or adjectives of like effect or import are used it shall be understood as if the expression were followed by the words "the Contracting Officer".

When such terms are used to describe a requirement, direction, review or judgment of the Contracting Officer as to the Work, it is intended that such requirement, direction, review or judgment will be solely to evaluate the Work for compliance with the Contract Documents (unless there is a specific statement indicating otherwise).

2.2.3 The use of any such term or adjective shall not be effective to assign to the AUTHORITY any duty of authority to supervise or direct the furnishing or performance of the Work or any duty or authority to undertake responsibility contrary to the provisions of paragraphs 2.3 or 2.4.

### **2.3 Means & Methods:**

The means, methods, techniques, sequences or procedures of construction, or safety precautions and the program incident thereto, and the failure to perform or furnish the Work in accordance with the Contract Documents are the sole responsibility of the CONTRACTOR.

### **2.4 Visits to Site/Place of Business:**

The Contracting Officer will make visits to the site and approved remote storage sites at intervals appropriate to the various stages of construction to observe the progress and quality of the executed Work and to determine, in general, if the Work is proceeding in accordance with the Contract Documents. The Contracting Officer may, at reasonable times, inspect that part of the plant or place of business of the CONTRACTOR or Subcontractor that is related to the performance of the Contract. Such observations or the lack of such observations shall in no way relieve the CONTRACTOR from his duty to perform the Work in accordance with the Contract Documents.

## **ARTICLE 3 - CONTRACT DOCUMENTS: INTENT, AMENDING, REUSE**

### **3.1 Incomplete Contract Documents:**

The submission of a bid by the Bidder is considered a representation that the Bidder examined the Contract Documents to make certain that all sheets and pages were provided and that the Bidder is satisfied as to the conditions to be encountered in performing the Work. The AUTHORITY expressly denies any responsibility or liability for a bid submitted on the basis of an incomplete set of Contract Documents.

### **3.2 Copies of Contract Documents:**

The AUTHORITY shall furnish to the CONTRACTOR up to six copies of the Contract Documents. Additional copies will be furnished, upon request, at the cost of reproduction.

### **3.3 Scope of Work:**

The Contract Documents comprise the entire Contract between the AUTHORITY and the CONTRACTOR concerning the Work. The Contract Documents are complementary; what is called for by one is as binding as if called for by all. The Contract Documents will be construed in accordance with the Regulatory Requirements of the place of the Project.

It is specifically agreed between the parties executing this Contract that it is not intended by any of the provisions of the Contract to create in the public or any member thereof a third party benefit, or to authorize anyone not a party to this Contract to maintain a suit pursuant to the terms or provisions of the Contract.

### **3.4 Intent of Contract Documents:**



- 3.4.1 It is the intent of the Contract Documents to describe a functionally complete Project to be constructed in accordance with the Contract Documents. Any Work, materials or equipment that may reasonably be inferred from the Contract Documents as being required to produce the intended result will be supplied, without any adjustment in Contract Price or Contract Time, whether or not specifically called for.
- 3.4.2 Reference to standard specifications, manuals or codes of any technical society, organization or association, or to the Regulatory Requirements of any governmental authority, whether such reference be specific or by implication, shall mean the edition stated in the Contract Documents or if not stated the latest standard specification, manual, code or Regulatory Requirements in effect at the time of Advertisement for the Project (or, on the Effective Date of the Contract if there was no Advertisement). However, no provision of any referenced standard specification, manual or code (whether or not specifically incorporated by reference in the Contract Documents) shall be effective to change the duties and responsibilities of the AUTHORITY and the CONTRACTOR, or any of their consultants, agents or employees from those set forth in the Contract Documents, nor shall it be effective to assign to the AUTHORITY or any of the AUTHORITY's Consultants, agents or employees, any duty or authority to supervise or direct the furnishing or performance of the Work or any duty or authority to undertake responsibility contrary to the provisions of paragraphs 2.3.

### **3.5 Discrepancy in Contract Documents:**

- 3.5.1 Before undertaking the Work, the CONTRACTOR shall carefully study and compare the Contract Documents and check and verify pertinent figures, and dimensions shown thereon and all applicable field measurements. Work in the area by the CONTRACTOR shall imply verification of figures, dimensions and field measurements. If, during the above study or during the performance of the Work, the CONTRACTOR finds a conflict, error, discrepancy or omission in the Contract Documents, or a discrepancy between the Contract Documents and any standard specification, manual, code, or Regulatory Requirement which affects the Work, the CONTRACTOR shall promptly report such discrepancy in writing to the Contracting Officer. The CONTRACTOR shall obtain a written interpretation or clarification from the Contracting Officer before proceeding with any Work affected thereby. Any adjustment made by the CONTRACTOR without this determination shall be at his own risk and expense. However, the CONTRACTOR shall not be liable to the AUTHORITY for failure to report any conflict, error or discrepancy in the Contract Documents unless the CONTRACTOR had actual knowledge thereof or should reasonably have known thereof.

#### **3.5.2 Discrepancy - Order of Precedence:**

When conflicts errors or discrepancies within the Contract Documents exist, the order of precedence from most governing to least governing will be as follows:

- Contents of Addenda
- Supplementary Conditions
- General Conditions
- General Requirements
- Technical Specifications
- Drawings
- Recorded dimensions will govern over scaled dimensions
- Large scale details over small scale details

Schedules over plans  
Architectural drawings over structural drawings Structural drawings over mechanical  
and electrical drawings

### **3.6 Clarifications and Interpretations:**

The Contracting Officer will issue with reasonable promptness such written clarifications or interpretations of the requirements of the Contract Documents as the Contracting Officer may determine necessary, which shall be consistent with or reasonably inferable from the overall intent of the Contract Documents.

### **3.7 Reuse of Documents:**

Neither the CONTRACTOR nor any Subcontractor, or Supplier or other person or organization performing or furnishing any of the Work under a direct or indirect contract with the AUTHORITY shall have or acquire any title to or ownership rights in any of the Contract Documents (or copies thereof) prepared by or for the AUTHORITY and they shall not reuse any of the Contract Documents on extensions of the Project or any other project without written consent of the Contracting Officer.

Contract Documents prepared by the CONTRACTOR in connection with the Work shall become the property of the AUTHORITY.

## **ARTICLE 4 - LANDS AND PHYSICAL CONDITIONS**

### **4.1 Availability of Lands:**

The AUTHORITY shall furnish as indicated in the Contract Documents, the lands upon which the Work is to be performed, rights-of-way and easements for access thereto, and such other lands which are designated for use of the CONTRACTOR in connection with the Work. Easements for permanent structures or permanent changes in existing facilities will be obtained and paid for by the AUTHORITY, unless otherwise provided in the Contract Documents. The CONTRACTOR shall provide for all additional lands and access thereto that may be required for temporary construction facilities or storage of materials and equipment. The CONTRACTOR shall provide all waste and disposal areas, including disposal areas for hazardous or contaminated materials, at no additional cost to the AUTHORITY.

### **4.2 Visit to Site:**

The submission of a bid by the CONTRACTOR is considered a representation that the CONTRACTOR has visited and carefully examined the site and is satisfied as to the conditions to be encountered in performing the Work and as to the requirements of the Contract Documents.

### **4.3 Explorations and Reports:**

Reference is made to the Supplementary Conditions for identification of those reports of explorations and tests of subsurface conditions at the site that have been utilized by the AUTHORITY in preparation of the Contract Documents. The CONTRACTOR may for his

purposes rely upon the accuracy of the factual data contained in such reports, but not upon interpretations or opinions drawn from such factual data contained therein or for the completeness or sufficiency thereof. Except as indicated in the immediately preceding sentence and in paragraphs 4.4 and 9.9, CONTRACTOR shall have full responsibility with respect to surface and subsurface conditions at the site.

#### **4.4 Utilities:**

- 4.4.1 The horizontal and vertical locations of known underground utilities as shown or indicated by the Contract Documents are approximate and are based on information and data furnished to the AUTHORITY by the owners of such underground utilities.
- 4.4.2 The CONTRACTOR shall have full responsibility for:
  - a. Reviewing and checking all information and data concerning utilities.
  - b. Locating all underground utilities shown or indicated in the Contract Documents which are affected by the Work.
  - c. Coordination of the Work with the owners of all utilities during construction.
  - d. Safety and protection of all utilities as provided in paragraph 6.17.
  - e. Repair of any damage to utilities resulting from the Work in accordance with 4.4.4 and 4.5.
- 4.4.3 If Work is to be performed by any utility owner, the CONTRACTOR shall cooperate with such owners to facilitate the Work.
- 4.4.4 In the event of interruption to any utility service as a result of accidental breakage or as result of being exposed or unsupported, the CONTRACTOR shall promptly notify the utility owner and the Project Manager. If service is interrupted, repair work shall be continuous until the service is restored. No Work shall be undertaken around fire hydrants until provisions for continued service has been approved by the local fire authority.

#### **4.5 Damaged Utilities:**

When utilities are damaged by the CONTRACTOR, the utility owner shall have the choice of repairing the utility or having the CONTRACTOR repair the utility. In the following circumstances, the CONTRACTOR shall reimburse the utility owner for repair costs or provide at no cost to the utility owner or the AUTHORITY, all materials, equipment and labor necessary to complete repair of the damage:

- a. When the utility is shown or indicated in the Contract Documents.
- b. When the utility has been located by the utility owner.
- c. When no locate was requested by the CONTRACTOR for utilities shown or indicated in the Contract Documents.
- d. All visible utilities.

- e. When the CONTRACTOR could have, otherwise, reasonably been expected to be aware of such utility.

#### **4.6 Utilities Not Shown or Indicated:**

If, while directly performing the Work, an underground utility is uncovered or revealed at the site which was not shown or indicated in the Contract Documents and which the CONTRACTOR could not reasonably have been expected to be aware of, the CONTRACTOR shall, promptly after becoming aware thereof and before performing any Work affected thereby (except in an emergency as permitted by paragraph 6.19) identify the owner of such underground utility and give written notice thereof to that owner and to the Project Manager. The Project Manager will promptly review the underground utility to determine the extent to which the Contract Documents and the Work should be modified to reflect the impacts of the discovered utility. The Contract Documents will be amended or supplemented in accordance with paragraph 9.2 and to the extent necessary through the issuance of a change document by the Contracting Officer. During such time, the CONTRACTOR shall be responsible for the safety and protection of such underground utility as provided in paragraph 6.17. The CONTRACTOR may be allowed an increase in the Contract Price or an extension of the Contract Time, or both, to the extent that they are directly attributable to the existence of any underground utility that was not shown or indicated in the Contract Documents and which the CONTRACTOR could not reasonably have been expected to be aware of.

#### **4.7 Survey Control:**

The AUTHORITY will identify sufficient horizontal and vertical control data to enable the CONTRACTOR to survey and layout the Work. All survey work shall be performed under the direct supervision of a registered land surveyor when required by paragraph 7.8. Copies of all survey notes shall be provided to the AUTHORITY at an interval determined by the Project Manager. The Project Manager may request submission on a weekly or longer period at his discretion. Any variations between the Contract Documents and actual field conditions shall be identified in the survey notes. Survey notes are to be in a format acceptable to the AUTHORITY.

### **ARTICLE 5 - BONDS, INSURANCE, AND INDEMNIFICATION**

#### **5.1 Delivery of Bonds:**

When the CONTRACTOR delivers the executed Contract to the Contracting Officer, the CONTRACTOR shall also deliver to the Contracting Officer such bonds as the CONTRACTOR may be required to furnish in accordance with paragraph 5.2.

#### **5.2 Bonds:**

- 5.2.1 The CONTRACTOR shall furnish Performance and Payment Bonds, each in an amount as shown on the Contract as security for the faithful performance and payment of all CONTRACTOR's obligations under the Contract Documents. These bonds shall remain in effect for one year after the date of Final Acceptance and until all obligations under this Contract, except special guarantees as per 12.7, have been met. All bonds shall be furnished on forms provided by the AUTHORITY (or copies thereof) and shall be executed by such Sureties as are authorized to do business in the State of Alaska. The Contracting Officer may at his option copy the Surety with notice of any potential default or liability.

### 5.3 Replacement of Bond and Surety:

If the Surety on any bond furnished in connection with this Contract is declared bankrupt or becomes insolvent or its right to do business is terminated in any state where any part of the Project is located or it ceases to meet the requirements of paragraph 5.2, or otherwise becomes unacceptable to the AUTHORITY, or if any such Surety fails to furnish reports as to his financial condition as requested by the AUTHORITY, the CONTRACTOR shall within five days thereafter substitute another bond and Surety, both of which must be acceptable to AUTHORITY.

An individual Surety may be replaced by a corporate Surety during the course of the Contract period. If the Surety desires to dispose of the collateral posted, the AUTHORITY may, at its option, accept substitute collateral.

### 5.4 Insurance Requirements:

5.4.1 The CONTRACTOR shall provide evidence of insurance with a carrier or carriers satisfactory to the AUTHORITY covering injury to persons and/or property suffered by the Alaska Energy Authority or a third party, as a result of operations which arise both out of and during the course of this Contract by the CONTRACTOR or by any Subcontractor. This coverage will also provide protection against injuries to all employees of the CONTRACTOR and the employees of any Subcontractor engaged in Work under this Contract.

5.4.2 The CONTRACTOR shall maintain in force at all times during the performance of Work under this agreement the following policies and minimum limits of liability. Where specific limits and coverages are shown, it is understood that they shall be the minimum acceptable. The requirements of this paragraph shall not limit the CONTRACTOR's responsibility to indemnify under paragraph 5.5. Additional insurance requirements specific to this Contract are contained in the Supplementary Conditions, when applicable.

a. Workers' Compensation Insurance: The Contractor shall provide and maintain, for all employees of the Contractor engaged in work under this contract, Workers' Compensation Insurance as required by AS 23.30.045. The Contractor shall be responsible for Workers' Compensation Insurance for any subcontractor who provides services under this contract, to include:

1. Waiver of subrogation against the Authority and Employer's Liability Protection in the amount of \$500,000 each accident/\$500,000 each disease.
2. If the Contractor directly utilizes labor outside of the State of Alaska in the prosecution of the work, "Other States" endorsement shall be required as a condition of the contract.
3. Whenever the work involves activity on or about navigable waters, the Workers' Compensation policy shall contain a United States Longshoreman's and Harbor Worker's Act endorsement, and when appropriate, a Maritime Employer's Liability (Jones Act) endorsement with a minimum limit of \$1,000,000.

b. Commercial General Liability Insurance: on an occurrence policy form covering all operations by or on behalf of the CONTRACTOR with combined single limits not less than:

1. If the CONTRACTOR carries a *Comprehensive General Liability* policy, the limits of liability shall not be less than a Combined Single Limit for bodily injury, property damage and Personal Injury Liability of:
  - \$1,000,000 each occurrence
  - \$2,000,000 aggregate
2. If the CONTRACTOR carries a *Commercial General Liability* policy, the limits of liability shall not be less than:
  - \$1,000,000 each occurrence (Combined Single Limit for bodily injury and property damage)
  - \$1,000,000 for Personal Injury Liability
  - \$2,000,000 aggregate for Products-Completed Operations
  - \$2,000,000 general aggregate

The Authority and the Owner shall be named as "Additional Insured" under all liability coverages listed above.

- c. Automobile Liability Insurance: covering all vehicles used by the Contractor in the performance of services under this agreement with combined single limits not less than:
    - \$1,000,000 each occurrence
  - d. Builder's Risk Insurance: Coverage shall be on an "All Risk" completed value basis including "quake and flood" and protect the interests of the AUTHORITY, the CONTRACTOR and Subcontractors at all tiers. Coverage shall include all materials, supplies and equipment that are intended for specific installation in the Project while such materials, supplies and equipment are located at the Project site, in transit from port of arrival to job site, or while temporarily located away from the Project site.
 

In addition to providing the above coverages the CONTRACTOR shall require that all indemnities obtained from any SUBCONTRACTORS be extended to include the Authority and Owner as an additional named indemnitees. CONTRACTOR shall further require that the Authority and the Owner be named as additional insured on all liability insurance policies maintained by all SUBCONTRACTORS under their contracts with CONTRACTOR, and that an appropriate waiver of subrogation in favor of the Authority be obtained with respect to all other insurance policies.
  - e. Other Coverages: As specified in the Supplementary Conditions, if required.
- 5.4.3
- a. In addition to providing the above coverages the Contractor shall, in any contract or agreement with subcontractors performing work, require that all indemnities and waivers of subrogation it obtains, and that any stipulation to be named as an additional insured it obtains, also be extended to waive rights of subrogation against the AUTHORITY and the Owner and to add the ALASKA ENERGY AUTHORITY and the Owner as additional named indemnitees and as additional insured.
  - b. Evidence of insurance shall be furnished to the AUTHORITY prior to the award of the contract. Such evidence, executed by the carrier's representative and

issued to the AUTHORITY, shall consist of a certificate of insurance or the policy declaration page with required endorsements attached thereto which denote the type, amount, class of operations covered, effective (and retroactive) dates, and dates of expiration. Acceptance by the AUTHORITY of deficient evidence does not constitute a waiver of contract requirements.

- c. When a certificate of insurance is furnished, it shall contain the following statement:  
"This is to certify that the policies described herein comply with all aspects of the insurance requirements of (Project Name and Number)."

#### **5.5 Indemnification:**

The CONTRACTOR shall indemnify, save harmless, and defend the AUTHORITY, the OWNER its agents and its employees from any and all claims, actions, or liabilities for injuries or damages sustained by any person or property arising directly or indirectly from the CONTRACTOR or SUBCONTRACTOR's performance of WORK under this Contract; however, this provision has no effect if, but only if, the sole proximate cause of the injury or damage is the AUTHORITY's negligence.

### **ARTICLE 6 - CONTRACTOR'S RESPONSIBILITIES**

#### **6.1 Supervision of Work:**

The CONTRACTOR shall supervise and direct the Work competently and efficiently, devoting such attention thereto and applying such skills and expertise as may be necessary to perform the Work in accordance with the Contract Documents. All Work under this Contract shall be performed in a skillful and workmanlike manner. The CONTRACTOR shall be solely responsible for the means, methods, techniques, sequences and procedures of construction.

#### **6.2 Superintendence by CONTRACTOR:**

The CONTRACTOR shall keep on the Work at all times during its progress a competent resident superintendent. The Project Manager shall be advised in writing of the superintendent's name, local address, and telephone number. This written advice is to be kept current until Final Acceptance by the AUTHORITY. The superintendent will be the CONTRACTOR's representative at the site and shall have full authority to act and sign documents on behalf of the CONTRACTOR.

All communications given to the superintendent shall be as binding as if given to the CONTRACTOR. The CONTRACTOR shall cooperate with the Project Manager in every way possible.

#### **6.3 Character of Workers:**

The CONTRACTOR shall provide a sufficient number of competent, suitably qualified personnel to survey and lay out the Work and perform construction as required by the Contract Documents. The CONTRACTOR shall at all times maintain good discipline and order at the site. The Project Manager may, in writing, require the CONTRACTOR to remove from the Work any employee the Project Manager deems incompetent, careless, or otherwise detrimental to the progress of the Work, but the Project Manager shall have no duty to exercise this right.

#### **6.4 CONTRACTOR to Furnish:**

Unless otherwise specified in the General Requirements, the CONTRACTOR shall furnish and assume full responsibility for all materials, equipment and machinery, tools, appliances, fuel, power, light, heat, telephone, water, sanitary facilities, temporary facilities and all other facilities and incidentals necessary for the furnishing, performance testing, start-up and completion of the Work.

#### **6.5 Materials and Equipment:**

All materials and equipment shall be of specified quality and new, except as otherwise provided in the Contract Documents. If required by the Project Manager, the CONTRACTOR shall furnish satisfactory evidence (including reports of required tests) as to the kind and quality of materials and equipment. All materials and equipment shall be applied, installed, connected, erected, used, cleaned, and conditioned in accordance with the instructions of the applicable Supplier except as otherwise provided in the Contract Documents; but no provision of any such instructions will be effective to assign to the AUTHORITY or any of the AUTHORITY's consultants, agents or employees, any duty or authority to supervise or direct the furnishing or performance of the Work or any duty or authority to undertake responsibility contrary to the provisions of paragraph 2.3.

#### **6.6 Anticipated Schedules:**

6.6.1 Prior to submitting the CONTRACTOR's first Application for Payment the CONTRACTOR shall submit to the Project Manager for review an anticipated progress schedule indicating the starting and completion dates of the various stages of the Work.

6.6.2 Prior to submitting the CONTRACTOR's first Application for Payment, the CONTRACTOR shall submit to the Project Manager for review:

Anticipated schedule of Shop Drawing submissions; and

Anticipated Schedule of Values for all of the Work which will include quantities and prices of items aggregating the Contract Price and will subdivide the Work into component parts in sufficient detail to serve as the basis for progress payments during construction. Such prices will include an appropriate amount of overhead and profit applicable to each item of Work which will be confirmed in writing by the CONTRACTOR at the time of submission.

#### **6.7 Finalizing Schedules:**

Prior to processing the first Application for Payment the Project Manager and the CONTRACTOR will finalize schedules required by paragraph 6.6. The finalized progress schedule will be acceptable to the AUTHORITY as providing information related to the orderly progression of the Work to completion within the Contract Time; but such acceptance will neither impose on the AUTHORITY nor relieve the CONTRACTOR from full responsibility for the progress or scheduling of the Work. If accepted, the finalized schedule of Shop Drawing and other required submissions will be acknowledgment by the AUTHORITY as providing a workable arrangement for processing the submissions. If accepted, the finalized Schedule of Values will be acknowledgment by the AUTHORITY as an approximation of anticipated value of Work accomplished over the anticipated Contract Time. Receipt and acceptance of a schedule submitted by the CONTRACTOR shall not be



construed to assign responsibility for performance or contingencies to the AUTHORITY or relieve the CONTRACTOR of his responsibility to adjust his forces, equipment, and work schedules as may be necessary to insure completion of the Work within prescribed Contract Time. Should the prosecution of the Work be discontinued for any reason, the CONTRACTOR shall notify the Project Manager at least 24 hours in advance of resuming operations.

## **6.8 Adjusting Schedules:**

Upon substantial changes to the schedule or upon request the CONTRACTOR shall submit to the Project Manager for acceptance (to the extent indicated in paragraph 6.7 and the General Requirements) adjustments in the schedules to reflect the actual present and anticipated progress of the Work.

## **6.9 Substitutes or "Or-Equal" Items:**

- 6.9.1 Whenever materials or equipment are specified or described in the Contract Documents by using the name of a proprietary item or the name of a particular Supplier the naming of the item is intended to establish the type, function and quality required. Unless the name is followed by words indicating that substitution is limited or not permitted, materials or equipment of other Suppliers may be accepted by the Project Manager only if sufficient information is submitted by the CONTRACTOR which clearly demonstrates to the Project Manager that the material or equipment proposed is equivalent or equal in all aspects to that named. The procedure for review by the Project Manager will include the following as supplemented in the General Requirements.
- 6.9.2 Requests for review of substitute items of material and equipment will not be accepted by the Project Manager from anyone other than the CONTRACTOR.
- 6.9.3 If the CONTRACTOR wishes to furnish or use a substitute item of material or equipment, the CONTRACTOR shall make written application to the Project Manager for Approval thereof, certifying that the proposed substitute will perform adequately the functions and achieve the results called for by the general design, be similar and of equal substance to that specified and be suited to the same use as the specified. The application will state that the evaluation and Approval of the proposed substitute will not delay the CONTRACTOR's timely achievement of Substantial or Final Completion, whether or not acceptance of the substitute for use in the Work will require a change in any of the Contract Documents (or in the provisions of any other direct contract with the AUTHORITY for Work on the Project) to adapt the design to the proposed substitute and whether or not incorporation or use of the substitute in connection with the Work is subject to payment of any license fee or royalty.
- 6.9.4 All variations of the proposed substitute from that specified will be identified in the application and available maintenance, repair and replacement service will be indicated. The application will also contain an itemized estimate of all costs that will result directly or indirectly from acceptance of such substitute, including costs of redesign and claims of other contractors affected by the resulting change, all of which shall be considered by the AUTHORITY in evaluating the proposed substitute. The AUTHORITY may require the CONTRACTOR to furnish at the CONTRACTOR's expense additional data about the proposed substitute. The Project Manager may reject any substitution request which the Project Manager determines is not in the best interest of the OWNER.

6.9.5 Substitutions shall be permitted during or after the bid period as allowed and in accordance with Document 00020 - Invitation for Bids, Document 00700 – General Conditions, and Document 01630 - Product Options and Substitutions.

#### **6.10 Substitute Means and Methods:**

If a specific means, method, technique, sequence or procedure of construction is indicated in or required by the Contract Documents, the CONTRACTOR may furnish or utilize a substitute means, method, sequence, technique or procedure of construction acceptable to the Project Manager, if the CONTRACTOR submits sufficient information to allow the Project Manager to determine that the substitute proposed is equivalent to that indicated or required by the Contract Documents. The procedure for review by the Project Manager will be similar to that provided in paragraph 6.9 as applied by the Project Manager and as may be supplemented in the General Requirements.

#### **6.11 Evaluation of Substitution:**

The Project Manager will be allowed a reasonable time within which to evaluate each proposed substitute. The Project Manager will be the sole judge of acceptability, and no substitute will be ordered, installed or utilized without the Contracting Officer's prior written Approval which will be evidenced by either a Change Order or a Shop Drawing Approved in accordance with Sections 6.20 and 6.21. The Contracting Officer may require the CONTRACTOR to furnish at the CONTRACTOR's expense a special performance guarantee or other Surety with respect to any substitute.

#### **6.12 Dividing the Work:**

The divisions and sections of the Specifications and the identifications of any Drawings shall not control the CONTRACTOR in dividing the Work among Subcontractors or Suppliers or delineating the Work to be performed by any specific trade.

#### **6.13 Subcontractors:**

The CONTRACTOR may utilize the services of appropriately licensed Subcontractors on those parts of the Work which, under normal contracting practices, are performed by Subcontractors, in accordance with the following conditions:

6.13.1 The CONTRACTOR shall not award any Work to any Subcontractor without prior written Approval of the Contracting Officer. This Approval will not be given until the CONTRACTOR submits to the Contracting Officer a written statement concerning the proposed award to the Subcontractor which shall contain required Equal Employment Opportunity documents, evidence of insurance whose limits are acceptable to the CONTRACTOR, and an executed copy of the subcontract. All subcontracts shall contain provisions for prompt payment, release of retainage, and interest on late payment amounts and retainage as specified in AS 36.90.210. Contracts between subcontractors, regardless of tier, must also contain these provisions.

6.13.2 The CONTRACTOR shall be fully responsible to the AUTHORITY for all acts and omissions of the Subcontractors, Suppliers and other persons and organizations performing or furnishing any of the Work under a direct or indirect contract with

CONTRACTOR just as CONTRACTOR is responsible for CONTRACTOR's own acts and omissions.

- 6.13.3 All Work performed for CONTRACTOR by a Subcontractor will be pursuant to an appropriate written agreement between CONTRACTOR and the Subcontractor which specifically binds the Subcontractor to the applicable terms and conditions of the Contract Documents for the benefit of the AUTHORITY and contains waiver provisions as required by paragraph 13.17 and termination provisions as required by Article 14.
- 6.13.4 Nothing in the Contract Documents shall create any contractual relationship between the AUTHORITY and any such Subcontractor, Supplier or other person or organization, nor shall it create any obligation on the part of the AUTHORITY to pay or to see to the payment of any moneys due any such Subcontractor, Supplier or other person or organization except as may otherwise be required by Regulatory Requirements. The AUTHORITY will not undertake to settle any differences between or among the CONTRACTOR, Subcontractors, or Suppliers.
- 6.13.5 The CONTRACTOR and Subcontractors shall coordinate their work and cooperate with other trades so to facilitate general progress of Work. Each trade shall afford other trades every reasonable opportunity for installation of their work and storage of materials. If cooperative work of one trade must be altered due to lack of proper supervision or failure to make proper provisions in time by another trade, such conditions shall be remedied by the CONTRACTOR with no change in Contract Price or Contract Time.
- 6.13.6 The CONTRACTOR shall include on his own payrolls any person or persons working on this Contract who are not covered by written subcontract, and shall ensure that all Subcontractors include on their payrolls all persons performing Work under the direction of the Subcontractor.

**6.14 Use of Premises:**

The CONTRACTOR shall confine construction equipment, the storage of materials and equipment and the operations of workers to the Project limits and approved remote storage sites and lands and areas identified in and permitted by Regulatory Requirements, rights-of-way, permits and easements, and shall not unreasonably encumber the premises with construction equipment or other materials or equipment. The CONTRACTOR shall assume full responsibility for any damage to any such land or area, or to the owner or occupant thereof or of any land or areas contiguous thereto, resulting from the performance of the Work. Should any claim be made against the AUTHORITY by any such owner or occupant because of the performance of the Work, the CONTRACTOR shall hold the AUTHORITY harmless.

**6.15 Structural Loading:**

The CONTRACTOR shall not load nor permit any part of any structure to be loaded in any manner that will endanger the structure, nor shall the CONTRACTOR subject any part of the Work or adjacent property to stresses or pressures that will endanger it.

**6.16 Record Documents:**

The CONTRACTOR shall maintain in a safe place at the site one record copy of all Drawings, Specifications, Addenda, Directives, Change Orders, Supplemental Agreements,

and written interpretations and clarifications (issued pursuant to paragraph 3.6) in good order and annotated to show all changes made during construction. These record documents together with all Approved samples and a counterpart of all Approved Shop Drawings will be available to the Project Manager for reference and copying. Upon completion of the Work, the annotated record documents, samples and Shop Drawings will be delivered to the Project Manager. Record documents shall accurately record variations in the Work which vary from requirements shown or indicated in the Contract Documents.

#### **6.17 Safety and Protection:**

The CONTRACTOR alone shall be responsible for initiating, maintaining and supervising all safety precautions and programs in connection with the Work. The CONTRACTOR shall take all necessary precautions for the safety of, and shall provide the necessary protection to prevent damage, injury or loss to:

- 6.17.1 All employees on the Work and other persons and organizations who may be affected thereby;
- 6.17.2 All the Work and materials and equipment to be incorporated therein, whether in storage on or off the site; and
- 6.17.3 Other property at the site or adjacent thereto, including trees, shrubs, lawns, walks, pavements, roadways, structures, and utilities not designated for removal, relocation or replacement in the course of construction.

The CONTRACTOR shall comply with all applicable Regulatory Requirements of any public body having jurisdiction for the safety of persons or property or to protect them from damage, injury or loss; and shall erect and maintain all necessary safeguards for such safety and protection. The CONTRACTOR shall notify owners of adjacent property and utility owners when prosecution of the Work may affect them, and shall cooperate with them in the protection, removal, relocation and replacement of their property. All damage, injury or loss to any property caused, directly or indirectly, in whole or in part, by the CONTRACTOR, any Subcontractor, Supplier or any other person or organization directly or indirectly employed by any of them to perform or furnish any of the Work or anyone for whose acts any of them may be liable, shall be remedied by the CONTRACTOR with no change in Contract Price or Contract Time except as stated in 4.6, except damage or loss attributable to unforeseeable causes beyond the control of and without the fault or negligence of the CONTRACTOR, including but not restricted to acts of God, of the public enemy or governmental authorities. The CONTRACTOR's duties and responsibilities for the safety and protection of the Work shall continue until Final Acceptance (except as otherwise expressly provided in connection with Substantial Completion).

#### **6.18 Safety Representative:**

The CONTRACTOR shall designate a responsible safety representative at the site. This person shall be the CONTRACTOR's superintendent unless otherwise designated in writing by the CONTRACTOR to the Project Manager.

#### **6.19 Emergencies:**

In emergencies affecting the safety or protection of persons or the Work or property at the site or adjacent thereto, the CONTRACTOR, without special instruction or authorization

from the AUTHORITY, is obligated to act to prevent threatened damage, injury or loss. The CONTRACTOR shall give the Project Manager prompt written notice if the CONTRACTOR believes that any significant changes in the Work or variations from the Contract Documents have been caused thereby. If the AUTHORITY determines that a change in the Contract Documents is required because of the action taken in response to an emergency, a change will be authorized by one of the methods indicated in Paragraph 9.2, as determined appropriate by the Project Manager.

## **6.20 Shop Drawings and Samples:**

- 6.20.1 After checking and verifying all field measurements and after complying with applicable procedures specified in the General Requirements, the CONTRACTOR shall submit to the Project Manager for review and Approval in accordance with the accepted schedule of Shop Drawing submissions the required number of all Shop Drawings, which will bear a stamp or specific written indication that the CONTRACTOR has satisfied CONTRACTOR's responsibilities under the Contract Documents with respect to the review of the submission. All submissions will be identified as the Project Manager may require. The data shown on the Shop Drawings will be complete with respect to quantities, dimensions, specified performance and design criteria, materials and similar data to enable the Project Manager to review the information as required.
- 6.20.2 The CONTRACTOR shall also submit to the Project Manager for review and Approval with such promptness as to cause no delay in Work, all samples required by the Contract Documents. All samples will have been checked by and accompanied by a specific written indication that the CONTRACTOR has satisfied CONTRACTOR's responsibilities under the Contract Documents with respect to the review of the submission and will be identified clearly as to material, Supplier, pertinent data such as catalog numbers and the use for which intended.
- 6.20.3 Before submission of each Shop Drawing or sample the CONTRACTOR shall have determined and verified all quantities, dimensions, specified performance criteria, installation requirements, materials, catalog numbers and similar data with respect thereto and reviewed or coordinated each Shop Drawing or sample with other Shop Drawings and samples and with the requirements of the Work and the Contract Documents.
- 6.20.4 At the time of each submission the CONTRACTOR shall give the Project Manager specific written notice of each variation that the Shop Drawings or samples may have from the requirements of the Contract Documents, and, in addition, shall cause a specific notation to be made on each Shop Drawing submitted to the Project Manager for review and Approval of each such variation. All variations of the proposed Shop Drawing from that specified will be identified in the submission and available maintenance, repair and replacement service will be indicated. The submittal will also contain an itemized estimate of all costs that will result directly or indirectly from acceptance of such variation, including costs of redesign and claims of other Contractors affected by the resulting change, all of which shall be considered by the AUTHORITY in evaluating the proposed variation. If the variation may result in a change of Contract Time or Price, or Contract responsibility, and is not minor in nature; the CONTRACTOR must submit a written request for Change Order with the variation to notify the AUTHORITY of his intent. The AUTHORITY may require the CONTRACTOR to furnish at the CONTRACTOR's expense additional data about the proposed variation. The Project Manager may reject any variation request which the Project Manager determines is not in the best interest of the AUTHORITY.

## **6.21 Shop Drawing and Sample Review:**

- 6.21.1 The Project Manager will review with reasonable promptness Shop Drawings and samples, but the Project Manager's review will be only for conformance with the design concept of the Project and for compliance with the information given in the Contract Documents and shall not extend to means, methods, techniques, sequences or procedures of construction (except where a specific means, method, technique, sequence or procedure of construction is indicated in or required by the Contract Documents) or to safety precautions or programs incident thereto. The review of a separate item as such will not indicate acceptance of the assembly in which the item functions. The CONTRACTOR shall make corrections required by the Project Manager and shall return the required number of corrected copies of Shop Drawings and submit as required new samples for review. The CONTRACTOR shall direct specific attention in writing to revisions other than the corrections called for by the Project Manager on previous submittals.
- 6.21.2 The Project Manager's review of Shop Drawings or samples shall not relieve CONTRACTOR from responsibility for any variation from the requirements of the Contract Documents unless the CONTRACTOR has in writing advised the Project Manager of each such variation at the time of submission as required by paragraph 6.20.4. The Contracting Officer if he so determines, may give written Approval of each such variation by Change Order, except that, if the variation is minor and no Change Order has been requested a specific written notation thereof incorporated in or accompanying the Shop Drawing or sample review comments shall suffice as a modification. Approval by the Contracting Officer will not relieve the CONTRACTOR from responsibility for errors or omissions in the Shop Drawings or from responsibility for having complied with the provisions of paragraph 6.20.3.
- 6.21.3 The AUTHORITY shall be responsible for all AUTHORITY review costs resulting from the initial submission and the resubmittal. The CONTRACTOR shall, at the discretion of the AUTHORITY, pay all review costs incurred by the AUTHORITY as a result of any additional re-submittals.
- 6.21.4 Where a Shop Drawing or sample is required by the Specifications, any related Work performed prior to the Project Manager's review and Approval of the pertinent submission will be the sole expense and responsibility of the CONTRACTOR.

## **6.22 Maintenance During Construction:**

The CONTRACTOR shall maintain the Work during construction and until Substantial Completion, at which time the responsibility for maintenance shall be established in accordance with paragraph 13.10.

## **6.23 Continuing the Work:**

The CONTRACTOR shall carry on the Work and adhere to the progress schedule during all disputes or disagreements with the AUTHORITY. No Work shall be delayed or postponed pending resolution of any disputes, disagreements, or claims except as the CONTRACTOR and the Contracting Officer may otherwise agree in writing.

## **6.24 Consent to Assignment:**

The CONTRACTOR shall obtain the prior written consent of the Contracting Officer to any proposed assignment of any interest in, or part of this Contract. The consent to any assignment or transfer shall not operate to relieve the CONTRACTOR or his Sureties of any of his or its obligations under this Contract or the Performance Bonds. Nothing herein contained shall be construed to hinder, prevent, or affect an assignment of monies due, or to become due hereunder, made for the benefit of the CONTRACTOR's creditors pursuant to law.

#### **6.25 Use of Explosives:**

6.25.1 When the use of explosives is necessary for the prosecution of the Work, the CONTRACTOR shall exercise the utmost care not to endanger life or property, including new Work and shall follow all Regulatory Requirements applicable to the use of explosives. The CONTRACTOR shall be responsible for all damage resulting from the use of explosives.

6.25.2 All explosives shall be stored in a secure manner in compliance with all Regulatory Requirements, and all such storage places shall be clearly marked. Where no Regulatory Requirements apply, safe storage shall be provided not closer than 1,000 feet from any building, camping area, or place of human occupancy.

6.25.3 The CONTRACTOR shall notify each public utility owner having structures in proximity to the site of his intention to use explosives. Such notice shall be given sufficiently in advance to enable utility owners to take such steps as they may deem necessary to protect their property from injury. However, the CONTRACTOR shall be responsible for all damage resulting from the use of the explosives, whether or not, utility owners act to protect their property.

#### **6.26 CONTRACTOR's Records:**

6.26.1 Records of the CONTRACTOR and Subcontractors relating to personnel, payrolls, invoices of materials, and any and all other data relevant to the performance of this Contract, must be kept on a generally recognized accounting system. Such records must be available during normal work hours to the Contracting Officer for purposes of investigation to ascertain compliance with Regulatory Requirements and provisions of the Contract Documents.

6.26.2 Payroll records must contain the name and address of each employee, his correct classification, rate of pay, daily and weekly number of hours of work, deductions made, and actual wages paid. The CONTRACTOR and Subcontractors shall make employment records available for inspection by the Contracting Officer and representatives of the U.S. and/or State Department of Labor and will permit such representatives to interview employees during working hours on the Project.

6.26.3 Records of all communications between the AUTHORITY and the CONTRACTOR and other parties, where such communications affected performance of this Contract, must be kept by the CONTRACTOR and maintained for a period of three years from Final Acceptance. The AUTHORITY or its assigned representative may perform an audit of these records during normal work hours after written notice to the CONTRACTOR.

#### **6.27 Load Restrictions**

The CONTRACTOR shall comply with all load restrictions as set forth in the

"Administrative Permit Manual", and Title 17, Chapter 25, of the Alaska Administrative Code in the hauling of materials on public roads, beyond the limits of the project, and on all public roads within the project limits that are scheduled to remain in use upon completion of the project.

Overload permits may, at the discretion of the State, be issued for travel beyond the project limits for purposes of mobilization and/or demobilization. Issuance of such a permit will not relieve the CONTRACTOR of liability for damage which may result from the moving of equipment.

The operation of equipment of such weight or so loaded as to cause damage to any type of construction will not be permitted. No overloads will be permitted on the base course or surface course under construction. No loads will be permitted on a concrete pavement, base or structure before the expiration of the curing period. The CONTRACTOR shall be responsible for all damage done by his equipment.

## **ARTICLE 7 - LAWS AND REGULATIONS**

### **7.1 Laws to be Observed**

The CONTRACTOR shall keep fully informed of all federal and state Regulatory Requirements and all orders and decrees of bodies or tribunals having any jurisdiction or authority, which in any manner affect those engaged or employed on the Work, or which in any way affect the conduct of the Work. The CONTRACTOR shall at all times observe and comply with all such Regulatory Requirements, orders and decrees; and shall protect and indemnify the AUTHORITY and its representatives against claim or liability arising from or based on the violation of any such Regulatory Requirement, order, or decree whether by the CONTRACTOR, Subcontractor, or any employee of either. Except where otherwise expressly required by applicable Regulatory Requirements, the AUTHORITY shall not be responsible for monitoring CONTRACTOR's compliance with any Regulatory Requirements.

### **7.2 Permits, Licenses, and Taxes**

7.2.1 The CONTRACTOR shall procure all permits and licenses, pay all charges, fees and taxes, and give all notices necessary and incidental to the due and lawful prosecution of the Work. As a condition of performance of this Contract, the CONTRACTOR shall pay all federal, state and local taxes incurred by the CONTRACTOR, in the performance of this Contract. Proof of payment of these taxes is a condition precedent to final payment by the AUTHORITY under this Contract.

7.2.2 The CONTRACTOR's certification that taxes have been paid (as contained in the *Release of Contract*) will be verified with the Department of Revenue and Department of Labor, prior to final payment.

7.2.3 If any federal, state or local tax is imposed, charged, or repealed after the date of bid opening and is made applicable to and paid by the CONTRACTOR on the articles or supplies herein contracted for, then the Contract shall be increased or decreased accordingly by a Change Order.

### **7.3 Patented Devices, Materials and Processes**



If the CONTRACTOR employs any design, device, material, or process covered by letters of patent, trademark or copyright, the CONTRACTOR shall provide for such use by suitable legal agreement with the patentee or owner. The CONTRACTOR and the Surety shall indemnify and save harmless the AUTHORITY, any affected third party, or political subdivision from any and all claims for infringement by reason of the use of any such patented design, device, material or process, or any trademark or copyright, and shall indemnify the AUTHORITY for any costs, expenses, and damages which it may be obliged to pay by reason of any infringement, at any time during the prosecution or after the completion of the Work.

#### **7.4 Compliance of Specifications and Drawings:**

If the CONTRACTOR observes that the Specifications and Drawings supplied by the AUTHORITY are at variance with any Regulatory Requirements, CONTRACTOR shall give the Project Manager prompt written notice thereof, and any necessary changes will be authorized by one of the methods indicated in paragraph 9.2. as determined appropriate by the Project Manager. If the CONTRACTOR performs any Work knowing or having reason to know that it is contrary to such Regulatory Requirements, and without such notice to the Project Manager, the CONTRACTOR shall bear all costs arising there from; however, it shall not be the CONTRACTOR's primary responsibility to make certain that the Specifications and Drawings supplied by the AUTHORITY are in accordance with such Regulatory Requirements.

#### **7.5 Accident Prevention:**

The CONTRACTOR shall comply with AS 18.60.075 and all pertinent provisions of the Construction Code Occupational Safety and Health Standards issued by the Alaska Department of Labor.

#### **7.6 Sanitary Provisions:**

The CONTRACTOR shall provide and maintain in a neat and sanitary condition such accommodations for the use of his employees and AUTHORITY representatives as may be necessary to comply with the requirements of the State and local Boards of Health, or of other bodies or tribunals having jurisdiction.

#### **7.7 Business Registration:**

Comply with AS 08.18.011, as follows: "it is unlawful for a person to submit a bid or work as a contractor until he has been issued a certificate of registration by the Department of Commerce. A partnership or joint venture shall be considered registered if one of the general partners or ventures whose name appears in the name under which the partnership or venture does business is registered."

#### **7.8 Professional Registration and Certification:**

All craft trades, architects, engineers and land surveyors, electrical administrators, and explosive handlers employed under the Contract shall specifically comply with applicable provisions of AS 08.18, 08.48, 08.40, and 08.52. Provide copies of individual licenses within seven days following a request from the Contracting Officer.

#### **7.9 Local Building Codes:**

The CONTRACTOR shall comply with AS 35.10.025 which requires construction in accordance with applicable local building codes to include the obtaining of required permits.

**7.10 Air Quality Control:**

The CONTRACTOR shall comply with all applicable provisions of AS 46.03.04 as pertains to Air Pollution Control.

**7.11 Archaeological or Paleontological Discoveries:**

When the CONTRACTOR's operation encounters prehistoric artifacts, burials, remains of dwelling sites, or paleontological remains, such as shell heaps, land or sea mammal bones or tusks, the CONTRACTOR shall cease operations immediately and notify the Project Manager. No artifacts or specimens shall be further disturbed or removed from the ground and no further operations shall be performed at the site until so directed. Should the Contracting Officer order suspension of the CONTRACTOR's operations in order to protect an archaeological or historical finding, or order the CONTRACTOR to perform extra Work, such shall be covered by an appropriate Contract change document.

**7.12 Applicable Alaska Preferences:** Not Applicable.

**7.13 Preferential Employment:** Not Applicable.

**7.14 Wages and Hours of Labor:**

7.14.1 One certified copy of all payrolls shall be submitted weekly to the State Department of Labor and, upon request, to the Contracting Officer to assure to assure compliance with AS 36.05.040, *Filing Schedule of Employees Wages Paid and Other Information*. The CONTRACTOR shall be responsible for the submission of certified copies of payrolls of all Subcontractors. The certification shall affirm that the payrolls are current and complete, that the wage rates contained therein are not less than the applicable rates referenced in these Contract Documents, and that the classification set forth for each laborer or mechanic conforms to the Work performed. The CONTRACTOR and his Subcontractors shall attend all hearings and conferences and produce such books, papers, and documents all as requested by the Department of Labor. Should federal funds be involved, the appropriate federal agency shall also receive a copy of the CONTRACTOR's certified payrolls. Regardless of project funding source, copies of all certified payrolls supplied to the State Department of Labor by the CONTRACTOR shall be supplied also to the Project Manager upon request, including submittals made by, or on behalf of, subcontractors.

7.14.2 The following labor provisions shall also apply to this Contract:

- a. The CONTRACTOR and his Subcontractors shall pay all employees unconditionally and not less than once a week;
- b. wages may not be less than those stated under AS 36.05.010, regardless of the contractual relationship between the CONTRACTOR or Subcontractors and laborers, mechanics, or field surveyors;
- c. the scale of wages to be paid shall be posted by the CONTRACTOR in a prominent and easily accessible place at the site of the Work;

d. the AUTHORITY shall withhold so much of the accrued payments as is necessary to pay to laborers, mechanics, or field surveyors employed by the CONTRACTOR or Subcontractors the difference between

1. the rates of wages required by the Contract to be paid laborers, mechanics, or field surveyors on the Work, and
2. the rates of wages in fact received by laborers, mechanics or field surveyors.

7.14.3 Within three calendar days of award of a construction contract, the CONTRACTOR shall file a "Notice of Work" with the Department of Labor and shall pay all related fees. The Contracting Officer will not issue Notice to Proceed to the CONTRACTOR until such notice and fees have been paid to the Department of Labor. Failure of the CONTRACTOR to file the Notice of Work and pay fees within this timeframe shall not constitute grounds for an extension of contract time or adjustment of contract price.

#### **7.15 Overtime Work Hours and Compensation:**

Pursuant to 40 U.S.C. 327-330 and AS 23.10.060 -.110, the CONTRACTOR shall not require nor permit any laborer or mechanic in any workweek in which he is employed on any Work under this Contract to work in excess of eight hours in any Calendar Day or in excess of forty hours in such workweek on Work subject to the provisions of the *Contract Work Hours and Safety Standards Act* unless such laborer or mechanic receives compensation at a rate not less than one and one half times his basic rate of pay for all such hours worked in excess of eight hours in any Calendar Day or in excess of forty hours in such workweek whichever is the greater number of overtime hours. In the event of any violation of this provision, the CONTRACTOR shall be liable to any affected employee for any amounts due and penalties and to the AUTHORITY for liquidated damages. Such liquidated damages shall be computed with respect to each individual laborer or mechanic employed in violation of this provision in the sum of \$10.00 for each Calendar Day on which such employee was required or permitted to be employed on such Work in excess of eight hours or in excess of the standard workweek of forty hours without payment of the overtime wages required by this paragraph.

#### **7.16 Covenant Against Contingent Fees:**

The CONTRACTOR warrants that no person or selling agent has been employed or retained to solicit or secure this Contract upon an agreement or understanding for a commission, percentage, brokerage, or contingent fee, excepting bona fide employees or bona fide established commercial or selling agencies maintained by the CONTRACTOR for the purpose of securing business. For breach or violation of this warrant, the DEPARTMENT shall have the right to annul this Contract without liability or, in its discretion, to deduct price of consideration from the Contract or otherwise recover the full amount of such commission, percentage, brokerage, or contingent fee.

#### **7.17 Officials Not to Benefit:**

No member of or delegate to the U.S. Congress, the Alaska State Legislature or other state official shall be admitted to any share or part of this Contract, nor to any benefit that may arise there from. However, this provision shall not be construed to extend to this Contract if made with a corporation for its general benefit.

#### **7.18 Personal Liability of Public Officials:**

In carrying out any of the provisions thereof, or in exercising any power or authority granted to the Contracting Officer by the Contract, there will be no liability upon the Contracting Officer nor upon AUTHORITY employees authorized as his representatives, either personally or as officials of the AUTHORITY, it being always understood that in such matters they act as agents and representatives of the AUTHORITY.

## **ARTICLE 8 - OTHER WORK**

### **8.1 Related Work at Site:**

- 8.1.1 The AUTHORITY reserves the right at any time to contract for and perform other or additional work on or near the Work covered by the Contract.
- 8.1.2 When separate contracts are let within the limits of the Project, the CONTRACTOR shall conduct his Work so as not to interfere with or hinder the work being performed by other contractors. The CONTRACTOR when working on the same Project with other contractors shall cooperate with such other contractors. The CONTRACTOR shall join his Work with that of the others in an acceptable manner and shall perform it in proper sequence to that of others.
- 8.1.3 If the fact that other such work is to be performed is identified or shown in the Contract Documents the CONTRACTOR shall assume all liability, financial or otherwise, in connection with this Contract and indemnify and save harmless the AUTHORITY from any and all damages or claims that may arise because of inconvenience, delay, or loss experienced by the CONTRACTOR because of the presence and operations of other contractors.
- 8.1.4 If the fact that such other work is to be performed was not identified or shown in the Contract Documents, written notice thereof will be given to the CONTRACTOR prior to starting any such other work. If the CONTRACTOR believes that such performance will require an increase in Contract Price or Contract Time, the CONTRACTOR shall notify the Project Manager of such required increase within fifteen (15) calendar days following receipt of the Contracting Officer's notice. Should the Project Manager find such increase(s) to be justified, a Change Order will be executed.

### **8.2 Access, Cutting, and Patching:**

The CONTRACTOR shall afford each utility owner and any other contractor who is a party to such a direct contract with the AUTHORITY (or the AUTHORITY, if the AUTHORITY is performing the additional work with the AUTHORITY's employees) proper and safe access to the site and a reasonable opportunity for the introduction and storage of materials and equipment and the execution of such work, and shall properly connect and coordinate the Work with the work of others. The CONTRACTOR shall do all cutting, fitting and patching of the Work that may be required to make its several parts come together properly and integrate with such other work, the CONTRACTOR shall not endanger any work of others by cutting, excavating or otherwise altering their work and will only cut or alter such other work with the written consent of the Project Manager. The duties and responsibilities of the CONTRACTOR under this paragraph are for the benefit of other contractors to the extent that there are comparable provisions for the benefit of the CONTRACTOR in said direct contracts between the AUTHORITY and other contractors.

### **8.3 Defective Work by Others:**

If any part of the CONTRACTOR's Work depends for proper execution or results upon the work of any such other contractor, utility owner, or the AUTHORITY, the CONTRACTOR shall inspect and promptly report to the Project Manager in writing any delays, defects or deficiencies in such work that render it unavailable or unsuitable for such proper execution and results. The CONTRACTOR's failure to so report will constitute an acceptance of the other work as fit and proper for integration with CONTRACTOR's Work except for latent or non-apparent defects and deficiencies in the other work.

#### **8.4 Coordination:**

If the AUTHORITY contracts with others for the performance of other work at the site, Project Manager will have authority and responsibility for coordination of the activities among the various prime contractors.

### **ARTICLE 9 - CHANGES**

#### **9.1 AUTHORITY's Right to Change**

Without invalidating the Contract and without notice to any Surety, the AUTHORITY may, at any time or from time to time, order additions, deletions or revisions in the Work within the general scope of the Contract, including but not limited to changes:

- 9.1.1 In the Contract Documents;
- 9.1.2 In the method or manner of performance of the Work;
- 9.1.3 In Authority-furnished facilities, equipment, materials, services, or site;
- 9.1.4 Directing acceleration in the performance of the Work.

#### **9.2 Authorization of Changes within the General Scope.**

Additions, deletions, or revisions in the Work within the general scope of the Contract as specified in 9.1 shall be authorized by one or more of following ways:

- 9.2.1 Directive (pursuant to paragraph 9.3)
- 9.2.2 A Change Order (pursuant to paragraph 9.4)
- 9.2.3 AUTHORITY's acceptance of Shop Drawing variations from the Contract Documents as specifically identified by the CONTRACTOR as required by paragraph 6.20.4.

#### **9.3 Directive**

- 9.3.1 The Contracting Officer shall provide written clarification or interpretation of the Contract Documents (pursuant to paragraph 3.6).
- 9.3.2 The Project Manager may authorize minor variations in the Work from the requirements of the Contract Documents which do not involve an adjustment in the Contract Price or the Contract Time and are consistent with the overall intent of the Contract Documents.

- 9.3.3 The Project Manager may order the Contractor to correct Defective Work or methods which are not in conformance with the Contract Documents.
- 9.3.4 The Project Manager may direct the commencement or suspension of Work or emergency related Work (as provided in paragraph 6.19).
- 9.3.5 Upon the issuance of a Directive to the CONTRACTOR by the Project Manager, the CONTRACTOR shall proceed with the performance of the Work as prescribed by such Directive.
- 9.3.6 If the CONTRACTOR believes that the changes noted in a Directive may cause an increase in the Contract Price or an extension of Contract Time, the CONTRACTOR shall immediately provide written notice to the Project Manager depicting such increases before proceeding with the Directive, except in the case of an emergency. If the Project Manager finds the increase in Contract Price or the extension of Contract Time justified, a Change Order will be issued. If however, the Project Manager does not find that a Change Order is justified, the Project Manager may direct the CONTRACTOR to proceed with the Work. The CONTRACTOR shall cooperate with the Project Manager in keeping complete daily records of the cost of such Work. If a Change Order is ultimately determined to be justified, in the absence of agreed prices and unit prices, payment for such Work will be made on a "cost of the work basis" as provided in 10.4

#### **9.4 Change Order**

A change in Contract Time, Contract Price, or responsibility may be made for changes within the scope of the Work by Change Order. Upon receipt of an executed Change Order, the CONTRACTOR shall promptly proceed with the Work involved which will be performed under the applicable conditions of the Contract Documents except as otherwise specifically provided. Changes in Contract Price and Contract Time shall be made in accordance with Articles 10 and 11. A Change Order shall be considered executed when it is signed by the AUTHORITY.

#### **9.5 Shop Drawing Variations**

Variations by shop drawings shall only be eligible for consideration under 9.4 when the conditions affecting the price, time, or responsibility are identified by the CONTRACTOR in writing and a request for a Change Order is submitted as per 6.20.4.

#### **9.6 Changes Outside the General Scope; Supplemental Agreement**

Any change which is outside the general scope of the Contract, as determined by the Project Manager, must be authorized by a Supplemental Agreement signed by the appropriate representatives of the AUTHORITY and the CONTRACTOR.

#### **9.7 Unauthorized Work:**

The CONTRACTOR shall not be entitled to an increase in the Contract Price or an extension of the Contract Time with respect to any work performed that is not required by the Contract Documents as amended, modified and supplemented as provided in this Article 9, except in the case of an emergency as provided in paragraph 6.19 and except in the case of uncovering Work as provided in paragraph 12.4.2.

## **9.8 Notification of Surety:**

If notice of any change affecting the general scope of the Work or the provisions of the Contract Documents (including, but not limited to, Contract Price or Contract Time) is required by the provisions of any bond to be given to a Surety, the giving of any such notice will be the CONTRACTOR's responsibility, and the amount of each applicable bond will be adjusted accordingly.

## **9.9 Differing Site Conditions:**

- 9.9.1 The CONTRACTOR shall promptly, and before such conditions are disturbed (except in an emergency as permitted by paragraph 6.19), notify the Project Manager in writing of: (1) subsurface or latent physical conditions at the site differing materially from those indicated in the Contract, and which could not have been discovered by a careful examination of the site, or (2) unknown physical conditions at the site, of an unusual nature, differing materially from those ordinarily encountered and generally recognized as inherent in work of the character provided for in this Contract. The Project Manager shall promptly investigate the conditions, and if the Project Manager finds that such conditions do materially so differ and cause an increase or decrease in the CONTRACTOR's cost of, or time required for, performance of this Contract, an equitable adjustment shall be made and the Contract modified in writing accordingly.
- 9.9.2 Any claim for additional compensation by the CONTRACTOR under this clause shall be made in accordance with Article 15. In the event that the Contracting Officer and the CONTRACTOR are unable to reach an agreement concerning an alleged differing site condition, the CONTRACTOR will be required to keep an accurate and detailed record which will indicate the actual "cost of the work" done under the alleged differing site condition. Failure to keep such a record shall be a bar to any recovery by reason of such alleged differing site conditions. The Project Manager shall be given the opportunity to supervise and check the keeping of such records.

## **9.10 Interim Work Authorization**

An Interim Work Authorization may be used to establish a change within the scope of the Work; however, only a Change Order shall establish associated changes in Contract Time and Price. Work authorized by Interim Work Authorization shall be converted to a Change Order. The basis of payment shall be as stated in the Interim Work Authorization, unless it states that the basis of payment has not been established and is to be negotiated, in which case the Cost of the Work shall be documented pursuant to Article 10.4, to establish a basis for negotiating a lump sum price for the Change Order.

# **ARTICLE 10 - CONTRACT PRICE; COMPUTATION AND CHANGE**

## **10.1 Contract Price:**

The Contract Price constitutes the total compensation (subject to authorized adjustments) payable to the CONTRACTOR for performing the Work. All duties, responsibilities and obligations assigned to or undertaken by the CONTRACTOR shall be at his expense without change in the Contract Price. The Contract Price may only be changed by a Change Order or Supplemental Agreement.

## **10.2 Claim for Price Change:**

Any claim for an increase or decrease in the Contract Price shall be submitted in accordance with the terms of Article 15, and shall not be allowed unless notice requirements of this Contract have been met.

## **10.3 Change Order Price Determination:**

The value of any Work covered by a Change Order for an increase or decrease in the Contract Price shall be determined in one of the following ways:

- 10.3.1 Where the Work involved is covered by unit prices contained in the Contract Documents, by application of unit prices to the quantities of the items involved (subject to the provisions of subparagraphs 10.9.1 through 10.9.3, inclusive).
- 10.3.2 By mutual acceptance of a lump sum price that includes overhead and profit. The following maximum rates of cost markup (to cover both overhead and profit of the CONTRACTOR) shall be used in the negotiation of a Lump Sum Change Order:
  - a. 17% - where a cost is borne directly by prime contractor (first tier contractor).
  - b. 10% - where a cost is borne by a subcontractor (lower tier contractor).

Where the cost is borne by a subcontractor acting as a first tier contractor, the allowable overhead and profit markup for lump sum change orders shall not exceed 17%. Any lower tier subcontractors, including the CONTRACTOR in this case, for whom the first tier subcontractor performs the work, shall be allowed an overhead and profit markup that does not exceed 10%.

- 10.3.3 When 10.3.1 and 10.3.2 are inapplicable, on the basis of the "cost of the work" (determined as provided in paragraphs 10.4 and 10.5) plus a CONTRACTOR's fee for overhead and profit (determined as provided in paragraph 10.6).
- 10.3.4 Before a Change Order or Supplemental Agreement is approved, the CONTRACTOR shall submit cost or pricing data regarding the changed or extra Work. The CONTRACTOR shall certify that the data submitted is, to his best knowledge and belief, accurate, complete and current as of a mutually determined specified date and that such data will continue to be accurate and complete during the performance of the changed or extra Work.

## **10.4 Cost of the Work:**

The term "cost of the work" means the sum of all costs necessarily incurred and paid by the CONTRACTOR in the proper performance of the Work. Except as otherwise may be agreed to in writing by the AUTHORITY, such costs shall be in amount no higher than those prevailing in the locality of the Project, shall include only the following items and shall not include any of the costs itemized in subparagraph 10.5:

- 10.4.1 Payroll costs for employees in the direct employ of the CONTRACTOR in the performance of the Work under schedules of job classifications agreed upon by the AUTHORITY and the CONTRACTOR. Payroll costs for employees not employed full time on the Work shall be apportioned on the basis of their time spent on the Work. Payroll costs shall include, but not be limited to, salaries and wages plus the cost of fringe benefits which shall include social security contributions, unemployment, excise



and payroll taxes, workers' or workmen's compensation, health and retirement benefits, bonuses, sick leave, vacation and holiday pay applicable thereto. Such employees shall include manual workers up through the level of foreman but shall not include general foremen, superintendents, and non-manual employees. The expenses of performing Work after regular working hours, on Saturday, Sunday or legal holidays shall be included in the above to the extent authorized by the AUTHORITY.

- 10.4.2 Cost of all materials and equipment furnished and incorporated or consumed in the Work, including costs of transportation and storage thereof, and Suppliers' field services required in connection therewith. All cash discounts shall accrue to the CONTRACTOR unless the AUTHORITY deposits funds with the CONTRACTOR with which to make payments, in which case the cash discounts shall accrue to the AUTHORITY. All trade discounts, rebates and refunds and all returns from sale of surplus materials and equipment shall accrue to the AUTHORITY, and the CONTRACTOR shall make provisions so that they may be obtained.
- 10.4.3 Payments made by the CONTRACTOR to Subcontractors for Work performed by Subcontractors. If required by the AUTHORITY, CONTRACTOR shall obtain competitive quotes from Subcontractors or Suppliers acceptable to the CONTRACTOR and shall deliver such quotes to the AUTHORITY who will then determine which quotes will be accepted. If a subcontract provides that the Subcontractor is to be paid on the basis of "cost of the work" plus a fee, the Subcontractor' "cost of the work" shall be determined in the same manner as the CONTRACTOR's "cost of work" as described in paragraphs 10.4 through 10.5; and the Subcontractor's fee shall be established as provided for under subparagraph 10.6.2 clause b. All subcontracts shall be subject to the other provisions of the Contract Documents insofar as applicable.
- 10.4.4 Costs of special consultants (including but not limited to engineers, architects, testing laboratories, and surveyors) employed for services necessary for the completion of the Work.
- 10.4.5 Supplemental costs including the following:
- a. The proportion of necessary transportation, travel and subsistence expenses of the CONTRACTOR's employees incurred in discharge of duties connected with the Work.
  - b. Cost, including transportation and maintenance, of all materials, supplies, equipment, machinery, appliances, office and temporary facilities at the site and hand tools not owned by the workers, which are consumed in the performance of the Work, and cost less market value of such items used but not consumed which remain the property of the CONTRACTOR.
  - c. Rentals of all construction equipment and machinery and the parts thereof whether rented from the CONTRACTOR or others in accordance with rental agreements Approved by the AUTHORITY and the costs of transportation, loading, unloading, installation, dismantling and removal thereof - all in accordance with terms of said rental agreements. The rental of any such equipment, machinery or parts shall cease when the use thereof is no longer necessary for the Work.

For any machinery or special equipment (other than small tools) which has been authorized by the Project Manager, the CONTRACTOR shall receive the rental rates in the current edition and appropriate volume of the "Rental Rate Blue Book for Construction Equipment", published by Dataquest, Inc., 1290 Ridder Park Drive, San Jose, CA 95131.

Hourly rental rates shall be determined as follows:

*The established hourly rental rate shall be equal to the adjusted monthly rate for the basic equipment plus the adjusted monthly rate for applicable attachments, both divided by 176, and multiplied by the area adjustment factor, plus the estimated hourly operating cost.*

The adjusted monthly rate is that resulting from application of the rate adjustment formula in order to eliminate replacement cost allowances in machine depreciation and contingency cost allowances.

Attachments shall not be included unless required for the time and materials work.

For equipment not listed in The Blue Book, the CONTRACTOR shall receive a rental rate as agreed upon before such work is begun. If agreement cannot be reached, the AUTHORITY reserves the right to establish a rate based on similar equipment in the Blue Book or prevailing commercial rates in the area.

These rates shall apply for equipment used during the CONTRACTOR's regular shift of 10 hours per day. Where the equipment is used more than 10 hours per day, either on the CONTRACTOR's normal work or on time and materials, and either on single or multiple shifts, an overtime rate, computed as follows, shall apply:

*The hourly overtime rate shall be equal to the adjusted monthly rate for the basic equipment plus the adjusted monthly rate for applicable attachments, both divided by 352, and multiplied by the area adjustment factor, plus the estimated hourly operating cost.*

Equipment which must be rented or leased specifically for work required under this section shall be authorized in writing by the Project Manager. The CONTRACTOR shall be paid invoice price plus 15%.

When it is necessary to obtain equipment from sources beyond the project limits exclusively for time and materials, work, the actual cost of transferring the equipment to the site of the work and return will be allowed as an additional item of expense. Where the move is made by common carrier, the move-in allowance will be limited to the amount of the freight bill or invoice. If the CONTRACTOR hauls the equipment with his own forces, the allowance will be limited to the rental rate for the hauling unit plus operator wages. In the event that the equipment is transferred under its own power, the moving allowance will be limited to one-half of the normal hourly rental rate plus operator's wages. In the event that the move-out is to a different location, payment will in no instance exceed the amount of the move-in. Move-in allowance shall not be made for equipment brought to the project for time and materials work which is subsequently retained on the project and utilized for completion of contract items, camp maintenance, or related work.

Equipment ordered to be on a stand-by basis shall be paid for at the stand-by rental rate for the number of hours in the CONTRACTOR'S normal work shift, but not to exceed 8 hours per day. The stand-by rental rate shall be computed as follows:

*The hourly stand-by rate shall be equal to the adjusted monthly rate for the basic equipment plus the adjusted monthly rate for applicable attachments, both divided by 352, all multiplied by the area adjustment factor.*

Time will be recorded to the nearest one-quarter hour for purposes of computing compensation to the CONTRACTOR for equipment utilized under these rates.

The equipment rates as determined above shall be full compensation, including overhead and profit, for providing the required equipment and no additional compensation will be made for other costs such as, but not limited to, fuels, lubricants, replacement parts or maintenance costs. Cost of repairs, both major and minor, as well as charges for mechanic's time utilized in servicing equipment to ready it for use prior to moving to the project and similar charges will not be allowed.

- d. Sales, consumer, use or similar taxes related to the Work, and for which the CONTRACTOR is liable, imposed by Regulatory Requirements.
- e. Deposits lost for causes other than negligence of the CONTRACTOR, any Subcontractor or anyone directly or indirectly employed by any of them or for whose acts any of them may be liable, and royalty payments and fees for permits and licenses.
- f. Losses and damages (and related expenses), not compensated by insurance or otherwise, to the Work or otherwise sustained by the CONTRACTOR in connection with the performance and furnishing of the Work provided they have resulted from causes other than the negligence of the CONTRACTOR, any Subcontractor, or anyone directly or indirectly employed by any of them or for whose acts any of them may be liable. Such losses shall include settlements made with the written consent and Approval of the AUTHORITY. No such losses, damages and expenses shall be included in the "cost of the work" for the purpose of determining the CONTRACTOR's fee. If, however, any such loss or damage requires reconstruction and the CONTRACTOR is placed in charge thereof, the CONTRACTOR shall be paid for services a fee proportionate to that stated in paragraphs 10.6.2.a and 10.6.2.b.
- g. The cost of utilities, fuel and sanitary facilities at the site.
- h. Minor expenses such as telegrams, long distance telephone calls, telephone service at the site, expressage and similar petty cash items in connection with the Work.
- i. Cost of premiums for additional bonds and insurance required because of changes in the Work and premiums for property insurance coverage within the limits of the deductible amounts established by the AUTHORITY in accordance with Article 5.

#### **10.5 Excluded Costs:**

The term "cost of the work" shall not include any of the following:

- 10.5.1 Payroll costs and other compensation of CONTRACTOR's officers, executives, principals (of partnership and sole proprietorships), general managers, engineers, architects, estimators, attorneys, auditors, accountants, purchasing agency, expeditors, timekeepers, clerks and other personnel employed by CONTRACTOR whether at the site or in CONTRACTOR's principal or a branch office for general administration of the Work and not specifically included in the agreed upon schedule of job classifications referred to in paragraph 10.4.1 or specifically covered by paragraph 10.4.4 all of which are to be considered administrative costs covered by the CONTRACTOR's fee.

- 10.5.2 Expenses of CONTRACTOR's principal and branch offices other than CONTRACTOR's office at the site.
- 10.5.3 Any part of CONTRACTOR's capital expenses including interest on CONTRACTOR's capital employed for the Work and charges against CONTRACTOR for delinquent payments.
- 10.5.4 Cost of premiums for all bonds and for all insurance whether or not CONTRACTOR is required by the Contract Documents to purchase and maintain the same (except for the cost of premiums covered by subparagraph 10.4.5.i above).
- 10.5.5 Costs due to the negligence of CONTRACTOR, any Subcontractor, or anyone directly or indirectly employed by any of them or for whose acts any of them may be liable, including but not limited to, the correction of Defective Work, disposal of materials or equipment wrongly supplied and making good any damage to property.
- 10.5.6 Other overhead or general expense costs of any kind and the costs of any item not specifically and expressly included in paragraph 10.4.

**10.6 CONTRACTOR's Fee:**

The CONTRACTOR's fee allowed to CONTRACTOR for overhead and profit shall be determined as follows.

- 10.6.1 A mutually acceptable fixed fee; or if none can be agreed upon.
- 10.6.2 A fee based on the following percentages of the various portions of the "cost of the work":
  - a. For costs incurred under paragraphs 10.4.1 and 10.4.2, the CONTRACTOR's fee shall be twenty percent;
  - b. For costs incurred under paragraph 10.4.3, the CONTRACTOR's fee shall be ten percent; and if a subcontract is on the basis of "cost of the work" plus a fee, the maximum allowable to CONTRACTOR on account of overhead and profit of all Subcontractors and multiple tiers thereof shall be fifteen percent;
  - c. No fee shall be payable on the basis of costs itemized under paragraphs 10.4.4, 10.4.5 and 10.5;
  - d. The amount of credit to be allowed by the CONTRACTOR to the AUTHORITY for any such change which results in a net decrease in cost will be the amount of the actual net decrease plus a deduction in CONTRACTOR's fee by an amount equal to ten percent of the net decrease; and
  - e. When both additions and credits are involved in any one change, the adjustment in CONTRACTOR's fee shall be computed on the basis of the net change in accordance with paragraphs 10.6.2.a through 10.6.2.d, inclusive.

## **10.7 Cost Breakdown:**

Whenever the cost of any Work is to be determined pursuant to paragraphs 10.4 and 10.5, the CONTRACTOR will submit in a form acceptable to the AUTHORITY an itemized cost breakdown together with supporting data.

## **10.8 Cash Allowances:**

It is understood that CONTRACTOR has included in the Contract Price all allowances so named in the Contract Documents and shall cause the Work so covered to be done by such Subcontractors or Suppliers and for such sums within the limit of the allowances as may be acceptable to the Contracting Officer. CONTRACTOR agrees that:

- 10.8.1 The allowances include the cost to CONTRACTOR (less any applicable trade discounts) of materials and equipment required by the allowances to be delivered at the site, and all applicable taxes; and
- 10.8.2 CONTRACTOR's cost for unloading and handling on the site, labor, installation costs, overhead, profit and other expenses contemplated for the allowances have been included in the Contract Price and not in the allowances. No demand for additional payment on account of any thereof will be valid.

Prior to final payment, an appropriate Change Order will be issued to reflect actual amounts due the CONTRACTOR on account of Work covered by allowances, and the Contract Price shall be correspondingly adjusted.

## **10.9 Unit Price Work:**

- 10.9.1 Where the Contract Documents provide that all or part of the Work is to be Unit Price Work, initially the Contract Price will be deemed to include for all Unit Price Work an amount equal to the sum of the established unit prices for each separately identified item of Unit Price Work times the estimated quantity of each item as indicated in the Contract. The estimated quantities of items of Unit Price Work are not guaranteed and are solely for the purpose of comparison of bids and determining an initial Contract Price. Determinations of the actual quantities and classifications of Unit Price Work performed by the CONTRACTOR will be made by the AUTHORITY in accordance with paragraph 10.10.
- 10.9.2 Each unit price will be deemed to include an amount considered by the CONTRACTOR to be adequate to cover the CONTRACTOR's overhead and profit for each separately identified item. If the "Basis of Payment" clause in the Contract Documents relating to any unit price in the bid schedule requires that the said unit price cover and be considered compensation for certain work or material essential to the item, this same work or material will not also be measured or paid for under any other pay item which may appear elsewhere in the Contract Documents.
- 10.9.3 Payment to the CONTRACTOR shall be made only for the actual quantities of Work performed and accepted or materials furnished, in conformance with the Contract Documents. When the accepted quantities of Work or materials vary from the quantities stated in the bid schedule, or change documents, the CONTRACTOR shall accept as payment in full, payment at the stated unit prices for the accepted quantities of Work and materials furnished, completed and accepted; except as provided below:

- a. When the quantity of Work to be done or material to be furnished under any item, for which the total cost of the item exceeds 10% of the total Contract Price, is increased by more than 25 percent of the quantity stated in the bid schedule, or change documents, either party to the Contract, upon demand, shall be entitled to an equitable unit price adjustment on that portion of the Work above 125 percent of the quantity stated in the bid schedule.
- b. When the quantity of Work to be done or material to be furnished under any major item, for which the total cost of the item exceeds 10% of the total Contract Price, is decreased by more than 25 percent of the quantity stated in the bid schedule, or change documents either party to the Contract, upon demand, shall be entitled to an equitable price adjustment for the quantity of Work performed or material furnished, limited to a total payment of not more than 75 percent of the amount originally bid for the item.

#### **10.10 Determinations for Unit Prices:**

The Project Manager will determine the actual quantities and classifications of Unit Price Work performed by the CONTRACTOR. The Project Manager will review with the CONTRACTOR preliminary determinations on such matters before finalizing the costs and quantities on the Schedule of Values. The Project Manager's acknowledgment thereof will be final and binding on the CONTRACTOR, unless, within 10 days after the date of any such decisions, the CONTRACTOR delivers to the Project Manager written notice of intention to appeal from such a decision.

### **ARTICLE 11 - CONTRACT TIME; COMPUTATION AND CHANGE**

#### **11.1 Commencement of Contract Time; Notice to Proceed:**

The Contract Time will commence to run on the day indicated in the Notice to Proceed.

#### **11.2 Starting the Work:**

No Work on Contract items shall be performed before the effective date of the Notice to Proceed. The CONTRACTOR shall notify the Project Manager at least 24 hours in advance of the time actual construction operations will begin. The CONTRACTOR may request a limited Notice to Proceed after Award has been made, to permit him to order long lead materials which could cause delays in Project completion. However, granting is within the sole discretion of the Contracting Officer, and refusal or failure to grant a limited Notice to Proceed shall not be a basis for claiming for delay, extension of time, or alteration of price.

#### **11.3 Computation of Contract Time:**

- 11.3.1 When the Contract Time is specified on a Calendar Day basis, all Work under the Contract shall be completed within the number of Calendar Days specified. The count of Contract Time begins on the day following receipt of the Notice to Proceed by the CONTRACTOR, if no starting day is stipulated therein.

Calendar Days shall continue to be counted against Contract Time until and including the date of Substantial Completion of the Work.

11.3.2 When the Contract completion time is specified as a fixed calendar date, it shall be the date of Final Completion.

11.3.3 The Contract Time shall be as stated is 00800, Supplementary Conditions.

**11.4 Time Change:**

The Contract Time may only be changed by a Change Order or Supplemental Agreement.

**11.5 Extension Due to Delays:**

The right of the CONTRACTOR to proceed shall not be terminated nor the CONTRACTOR charged with liquidated or actual damages because of delays to the completion of the Work due to unforeseeable causes beyond the control and without the fault or negligence of the CONTRACTOR, including, but not restricted to the following: acts of God or of the public enemy, acts of the AUTHORITY in its contractual capacity, acts of another contractor in the performance of a contract with the AUTHORITY, floods, fires, epidemics, quarantine restrictions, strikes, freight embargoes, unusually severe weather and delays of Subcontractors or Suppliers due to such causes. Any delay in receipt of materials on the site, caused by other than one of the specifically mentioned occurrences above, does not of itself justify a time extension, provided that the CONTRACTOR shall within twenty four (24) hours from the beginning of any such delay (unless the Contracting Officer shall grant a further period of the time prior to the date of final settlement of the Contract), notify the Project Manager in writing of the cause of delay. The Contracting Officer shall ascertain the facts and the extent of the delay and extend the time for completing the Work when the findings of fact justify such an extension.

## **11.6 Essence of Contract:**

All time limits stated in the Contract Documents are of the essence of the Contract.

## **11.7 Reasonable Completion Time:**

It is expressly understood and agreed by and between the CONTRACTOR and the AUTHORITY that the date of beginning and the time for Substantial Completion of the Work described herein are reasonable times for the completion of the Work.

## **11.8 Delay Damages:**

Whether or not the CONTRACTOR's right to proceed with the Work is terminated, he and his Sureties shall be liable for damages resulting from his refusal or failure to complete the Work within the specified time.

Liquidated and actual damages for delay shall be paid by the CONTRACTOR or his Surety to the AUTHORITY in the amount as specified in the Supplementary Conditions for each Calendar Day the completion of the Work or any part thereof is delayed beyond the time required by the Contract, or any extension thereof. If a listing of incidents resulting from a delay and expected to give rise to actual or liquidated damages is not established by the Contract Documents, then the CONTRACTOR and his Surety shall be liable to the AUTHORITY for any actual damages occasioned by such delay. The CONTRACTOR acknowledges that the liquidated damages established herein are not a penalty but rather constitute an estimate of damages that the AUTHORITY will sustain by reason of delayed completion. These liquidated and actual damages are intended as compensation for losses anticipated arising, and including those items enumerated in the Supplementary Conditions.

These damages will continue to run both before and after termination in the event of default termination. These liquidated damages do not cover excess costs of completion or AUTHORITY costs, fees, and charges related to reprocurement. If a default termination occurs, the CONTRACTOR or his Surety shall pay in addition to these damages, all excess costs and expenses related to completion as provided by Article 14.2.5.

For each calendar day that the work remains incomplete after the expiration of the Contract Time, liquidated damages in the amount as stated in 00800, Supplemental Conditions shall be assessed to the CONTRACTOR. If no money is due the CONTRACTOR, the AUTHORITY shall have the right to recover said sum from the CONTRACTOR, the surety or both. The amount of these deductions is to reimburse the AUTHORITY for estimated liquidated damages incurred as a result of the CONTRACTOR's failure to complete the work within the time specified. As liquidated damages, such deductions are not to be considered as penalties.

Permitting the CONTRACTOR to continue and finish the work or any part of it after the time fixed for its completion, or after the date to which the time for completion may have been extended, will in no way operate as a waiver on the part of the AUTHORITY of any of its rights under the Contract.

## **ARTICLE 12 - QUALITY ASSURANCE**

### **12.1 Warranty and Guaranty:**



The CONTRACTOR warrants and guarantees to the AUTHORITY that all Work will be in accordance with the Contract Documents and will not be Defective. Prompt notice of all defects shall be given to the CONTRACTOR. All Defective Work, whether or not in place, may be rejected, corrected or accepted as provided for in this article.

## **12.2 Access to Work:**

The AUTHORITY and the AUTHORITY's consultants, testing agencies and governmental agencies with jurisdiction interests will have access to the Work at reasonable times for their observation, inspecting and testing. The CONTRACTOR shall provide proper and safe conditions for such access.

## **12.3 Tests and Inspections:**

12.3.1 The CONTRACTOR shall give the Project Manager timely notice of readiness of the Work for all required inspections, tests or Approvals.

12.3.2 If Regulatory Requirements of any public body having jurisdiction require any Work (or part thereof) to specifically be inspected, tested or approved, the CONTRACTOR shall assume full responsibility therefore, pay all costs in connection therewith and furnish the Project Manager the required certificates of inspection, testing or approval. The CONTRACTOR shall also be responsible for and shall pay all costs in connection with any inspection or testing required in connection with AUTHORITY's acceptance of a Supplier of materials or equipment proposed to be incorporated in the Work, or of materials or equipment submitted for Approval prior to the CONTRACTOR's purchase thereof for incorporation in the Work. The cost of all inspections, tests and approvals in addition to the above which are required by the Contract Documents shall be paid by the CONTRACTOR. The AUTHORITY may perform additional tests and inspections which it deems necessary to insure quality control. All such failed tests or inspections shall be at the CONTRACTOR's expense.

12.3.4 If any Work (including the work of others) that is to be inspected, tested or Approved is covered without written concurrence of the Project Manager, it must, if requested by the Project Manager, be uncovered for observation. Such uncovering shall be at the CONTRACTOR's expense unless the CONTRACTOR has given the Project Manager timely notice of CONTRACTOR's intention to cover the same and the Project Manager has not acted with reasonable promptness in response to such notice.

12.3.5 Neither observations nor inspections, tests or Approvals by the AUTHORITY or others shall relieve the CONTRACTOR from the CONTRACTOR's obligations to perform the Work in accordance with the Contract Documents.

## **12.4 Uncovering Work:**

12.4.1 If any Work is covered contrary to the written request of the Project Manager, it must, if requested by the Project Manager, be uncovered for the Project Manager's observation and replaced at the CONTRACTOR's expense.

12.4.2 If the Project Manager considers it necessary or advisable that covered Work be observed inspected or tested, the CONTRACTOR, at the Project Manager's request, shall uncover, expose or otherwise make available for observation, inspection or testing as the Project Manager may require, that portion of the Work in question, furnishing all

necessary labor, material and equipment. If it is found that such Work is Defective, the CONTRACTOR shall bear all direct, indirect and consequential costs of such uncovering, exposure, observation, inspection and testing and of satisfactory reconstruction, (including but not limited to fees and charges of engineers, architects, attorneys and other professionals) and the AUTHORITY shall be entitled to an appropriate decrease in the Contract Price. If, however, such Work is not found to be Defective, the CONTRACTOR shall be allowed an increase in the Contract Price or an extension of the Contract Time, or both, directly attributable to such uncovering, exposure, observation, inspection, testing and reconstruction.

#### **12.5 AUTHORITY May Stop the Work:**

If the Work is Defective, or the CONTRACTOR fails to supply suitable materials or equipment, or fails to furnish or perform the Work in such a way that the completed Work will conform to the Contract Documents, the Contracting Officer may order the CONTRACTOR to stop the Work, or any portion thereof, until the cause for such order has been eliminated; however, this right of the Contracting Officer to stop the Work shall not give rise to any duty on the part of the Contracting Officer to exercise this right for the benefit of the CONTRACTOR or any other party.

#### **12.6 Correction or Removal of Defective Work:**

If required by the Project Manager, the CONTRACTOR shall promptly, as directed, either correct all Defective Work, whether or not fabricated, installed or completed, or, if the Work has been rejected by the Project Manager, remove it from the site and replace it with Work which conforms to the requirements of the Contract Documents. The CONTRACTOR shall bear all direct, indirect and consequential costs of such correction or removal (including but not limited to fees and charges of engineers, architects, attorneys and other professionals) made necessary thereby.

#### **12.7 One Year Correction Period:**

If within one year after the date of Substantial Completion of the relevant portion of the Work or such longer period of time as may be prescribed by Regulatory Requirements or by the terms of any applicable special guarantee required by the Contract Documents or by any specific provision of the Contract Documents, any Work is found to be Defective, the CONTRACTOR shall promptly, without cost to the AUTHORITY and in accordance with the Project Manager's written instructions, either correct such Defective Work, or, if it has been rejected by the Project Manager, remove it from the site and replace it with conforming Work. If the CONTRACTOR does not promptly comply with the terms of such instructions, or in an emergency where delay would cause serious risk of loss or damage, the AUTHORITY may have the Defective Work corrected or the rejected Work removed and replaced, and all direct, indirect and consequential costs of such removal and replacement (including but not limited to fees and charges of engineers, architects, attorneys and other professionals) will be paid by the CONTRACTOR. In special circumstances where a particular item of equipment is placed in continuous service for the benefit of the AUTHORITY before Substantial Completion of all the Work, the correction period for that item may begin on an earlier date if so provided in the Specifications or by Change Order. Provisions of this paragraph are not intended to shorten the statute of limitations for bringing an action.

#### **12.8 Acceptance of Defective Work:**

Instead of requiring correction or removal and replacement of Defective Work, the Project Manager may accept Defective Work, the CONTRACTOR shall bear all direct, indirect and consequential costs attributable to the Project Manager's evaluation of and determination to accept such Defective Work (costs to include but not be limited to fees and charges of engineers, architects, attorneys and other professionals). If any such acceptance occurs prior to final payment, a Change Order will be issued incorporating the necessary revisions in the Contract Documents with respect to the Work; and the AUTHORITY shall be entitled to an appropriate decrease in the Contract Price. If the AUTHORITY has already made final payment to the CONTRACTOR, an appropriate amount shall be paid by the CONTRACTOR or his Surety to the AUTHORITY.

### **12.9 AUTHORITY May Correct Defective Work:**

If the CONTRACTOR fails within a reasonable time after written notice from the Project Manager to proceed to correct Defective Work or to remove and replace rejected Work as required by the Project Manager in accordance with paragraph 12.6, or if the CONTRACTOR fails to perform the Work in accordance with the Contract Documents, or if the CONTRACTOR fails to comply with any other provision of the Contract Documents, the AUTHORITY may, after 7 days' written notice to the CONTRACTOR, correct and remedy any such deficiency. In exercising the rights and remedies under this paragraph the AUTHORITY shall proceed expeditiously. To the extent necessary to complete corrective and remedial action, the Project Manager may exclude the CONTRACTOR from all or part of the site, take possession of all or part of the Work, and suspend the CONTRACTOR's services related thereto, take possession of the CONTRACTOR's tools, appliances, construction equipment and machinery at the site and incorporate in the Work all materials and equipment stored at the site or approved remote storage sites or for which the AUTHORITY has paid the CONTRACTOR but which are stored elsewhere. The CONTRACTOR shall allow the Project Manager and his authorized representatives such access to the site as may be necessary to enable the Project Manager to exercise the rights and remedies under this paragraph. All direct, indirect and consequential costs of the AUTHORITY in exercising such rights and remedies will be charged against the CONTRACTOR, and a Change Order will be issued incorporating the necessary revisions in the Contract Documents with respect to the Work; and the AUTHORITY shall be entitled to an appropriate decrease in the Contract Price. Such direct, indirect and consequential costs will include but not be limited to fees and charges of engineers, architects, attorneys and other professionals, all court and arbitration costs and all costs of repair and replacement of work of others destroyed or damaged by correction, removal or replacement of the CONTRACTOR's Defective Work. The CONTRACTOR shall not be allowed an extension of time because of any delay in performance of the work attributable to the exercise, by the Project Manager, of the AUTHORITY's rights and remedies hereunder.

## **ARTICLE 13 - PAYMENTS TO CONTRACTOR AND COMPLETION**

### **13.1 Schedule of Values:**

The Schedule of Values established as provided in paragraph 6.6 will serve as the basis for progress payments and will be incorporated into a form of Application for Payment acceptable to the Project Manager. Progress payments on account of Unit Price Work will be based on the number of units completed.

### **13.2 Preliminary Payments:**

Upon approval of the Schedule of Values the CONTRACTOR may be paid for direct costs substantiated by paid invoices and other prerequisite documents required by the General Requirements. Direct costs shall include the cost of bonds, insurance, approved materials stored on the site or at approved remote storage sites, deposits required by a Supplier prior to fabricating materials, and other approved direct mobilization costs substantiated as indicated above. These payments shall be included as a part of the total Contract Price as stated in the Contract.

### **13.3 Application for Progress Payment:**

The CONTRACTOR shall submit to the Project Manager for review an Application for Payment filled out and signed by the CONTRACTOR covering the Work completed as of the date of the Application for Payment and accompanied by such supporting documentation as is required by the Contract Documents. Progress payments will be made as the Work progresses on a monthly basis.

### **13.4 Review of Applications for Progress Payment:**

Project Manager will either indicate in writing a recommendation of payment or return the Application for Payment to the CONTRACTOR indicating in writing the Project Manager's reasons for refusing to recommend payment. In the latter case, the CONTRACTOR may make the necessary corrections and resubmit the Application for Payment.

### **13.5 Stored Materials and Equipment:**

If payment is requested on the basis of materials and equipment not incorporated in the Work but delivered and suitably stored at the site or at another location agreed to in writing, the Application for Payment shall also be accompanied by a bill of sale, paid invoice or other documentation warranting that the AUTHORITY has received the materials and equipment free and clear of all charges, security interests and encumbrances and evidence that the materials and equipment are covered by appropriate property insurance and other arrangements to protect the AUTHORITY's interest therein, all of which will be satisfactory to the Project Manager. No payment will be made for perishable materials that could be rendered useless because of long storage periods. No progress payment will be made for living plant materials until planted.

### **13.6 CONTRACTOR's Warranty of Title:**

The CONTRACTOR warrants and guarantees that title to all Work, materials and equipment covered by any Application for Payment, whether incorporated in the Project or not, will pass to the AUTHORITY no later than the time of payment free and clear of any claims, liens, security interests and further obligations.

### **13.7 Withholding of Payments:**

The AUTHORITY may withhold or refuse payment for any of the reasons listed below provided it gives written notice of its intent to withhold and of the basis for withholding:

- 13.7.1 The Work is Defective, or completed Work has been damaged requiring correction or replacement, or has been installed without Approval of Shop Drawings, or by an unapproved Subcontractor, or for unsuitable storage of materials and equipment.

- 13.7.2 The Contract Price has been reduced by Change Order,
- 13.7.3 The AUTHORITY has been required to correct Defective Work or complete Work in accordance with paragraph I2.9.
- 13.7.4 The AUTHORITY's actual knowledge of the occurrence of any of the events enumerated in paragraphs I4.2.1.a through I4.2.1.k inclusive.
- 13.7.5 Claims have been made against the AUTHORITY or against the funds held by the AUTHORITY on account of the CONTRACTOR's actions or inactions in performing this Contract, or there are other items entitling the AUTHORITY to a set off.
- 13.7.6 Subsequently discovered evidence or the results of subsequent inspections or test, nullify any previous payments for reasons stated in subparagraphs 13.7.l through 13.7.5.
- 13.7.7 The CONTRACTOR has failed to fulfill or is in violation of any of his obligations under any provision of this Contract.

**13.8 Retainage:**

At any time the AUTHORITY finds that satisfactory progress is not being made it may in addition to the amounts withheld under 13.7 retain a maximum amount equal to 10% of the total amount earned on all subsequent progress payments. This retainage may be released at such time as the Project Manager finds that satisfactory progress is being made.

**13.9 Request for Release of Funds:**

If the CONTRACTOR believes the basis for withholding is invalid or no longer exists, immediate written notice of the facts and Contract provisions on which the CONTRACTOR relies, shall be given to the AUTHORITY, together with a request for release of funds and adequate documentary evidence proving that the problem has been cured. In the case of withholding which has occurred at the request of the Department of Labor, the CONTRACTOR shall provide a letter from the Department of Labor stating that withholding is no longer requested. Following such a submittal by the CONTRACTOR, the AUTHORITY shall have a reasonable time to investigate and verify the facts and seek additional assurances before determining whether release of withheld payments is justified.

**13.10 Substantial Completion:**

When the CONTRACTOR considers the Work ready for its intended use the CONTRACTOR shall notify the Project Manager in writing that the Work or a portion of Work which has been specifically identified in the Contract Documents is substantially complete (except for items specifically listed by the CONTRACTOR as incomplete) and request that the AUTHORITY issue a certificate of Substantial Completion. Within a reasonable time thereafter, the Project Manager, the CONTRACTOR and Engineer(s) shall make an inspection of the Work to determine the status of completion. If the Project Manager does not consider the Work substantially complete, the Project Manager will notify the CONTRACTOR in writing giving the reasons therefore. If the Project Manager considers the Work substantially complete, the Project Manager will within fourteen days execute and deliver to the CONTRACTOR a certificate of Substantial Completion with tentative list of items to be completed or corrected. At the time of delivery of the certificate of Substantial Completion the Project Manager will deliver to the CONTRACTOR a written

division of responsibilities pending Final Completion with respect to security, operation, safety, maintenance, heat, utilities, insurance and warranties which shall be consistent with the terms of the Contract Documents.

The AUTHORITY shall be responsible for all AUTHORITY costs resulting from the initial inspection and the first re-inspection, the CONTRACTOR shall pay all costs incurred by the AUTHORITY resulting from re-inspections, thereafter.

### **13.11 Access Following Substantial Completion:**

The AUTHORITY shall have the right to exclude the CONTRACTOR from the Work after the date of Substantial Completion, but the AUTHORITY shall allow CONTRACTOR reasonable access to complete or correct items on the tentative list.

### **13.12 Final Inspection:**

Upon written notice from the CONTRACTOR that the entire Work or an agreed portion thereof is complete, the Project Manager will make a final inspection with the CONTRACTOR and Engineer(s) and will notify the CONTRACTOR in writing of all particulars in which this inspection reveals that the Work is incomplete or Defective. The CONTRACTOR shall immediately take such measures as are necessary to remedy such deficiencies. The CONTRACTOR shall pay for all costs incurred by the AUTHORITY resulting from re-inspections.

### **13.13 Final Completion and Application for Payment:**

After the CONTRACTOR has completed all such corrections to the satisfaction of the Project Manager and delivered schedules, guarantees, bonds, certificates of payment to all laborers, Subcontractors and Suppliers, and other documents - all as required by the Contract Documents; and after the Project Manager has indicated in writing that the Work has met the requirements for Final Completion, and subject to the provisions of paragraph 13.18, the CONTRACTOR may make application for final payment following the procedure for progress payments. The final Application for Payment shall be accompanied by all remaining certificates, warranties, guarantees, releases, affidavits, and other documentation required by the Contract Documents.

### **13.14 Final Payment:**

13.14.1 If on the basis of the Project Manager's observation of the Work during construction and final inspection, and the Project Manager's review of the final Application for Payment and accompanying documentation - all as required by the Contract Documents; and the Project Manager is satisfied that the Work has been completed and the CONTRACTOR's other obligations under the Contract Documents have been fulfilled, the AUTHORITY will process final Application for Payment. Otherwise, the Project Manager will return the Application for Payment to the CONTRACTOR, indicating in writing the reasons for refusing to process final payment, in which case the CONTRACTOR shall make the necessary corrections and resubmit the final Application for Payment.

13.14.2 If, through no fault of the CONTRACTOR, Final Completion of the Work is significantly delayed, the Project Manager shall, upon receipt of the CONTRACTOR's final Application for Payment, and without terminating the Contract, make payment of

the balance due for that portion of the Work fully completed and accepted. If the remaining balance to be held by the AUTHORITY for Work not fully completed or corrected is less than the retainage provided for in paragraph 13.9, and if bonds have been furnished as required in paragraph 5.I, the written consent of the Surety to the payment of the balance due for that portion of the Work fully completed and accepted shall be submitted by the CONTRACTOR to the AUTHORITY with the application for such payment. Such payment shall be made under the terms and conditions governing final payment, except that it shall not constitute a waiver of claims.

**13.15 Final Acceptance:**

Following certification of payment of payroll and revenue taxes, and final payment to the CONTRACTOR, the AUTHORITY will issue a letter of Final Acceptance, releasing the CONTRACTOR from further obligations under the Contract, except as provided in paragraph 13.17.

When it is anticipated that restarting, testing, adjusting, or balancing of systems will be required following Final Acceptance and said requirements are noted in Section(s) 01650, such Work shall constitute a continuing obligation under the Contract.

**13.16 CONTRACTOR's Continuing Obligation:**

The CONTRACTOR's obligation to perform and complete the Work and pay all laborers, Subcontractors, and material men in accordance with the Contract Documents shall be absolute. Neither any progress or final payment by the AUTHORITY, nor the issuance of a certificate of Substantial Completion, nor any use or occupancy of the Work or any part thereof by the AUTHORITY or Owner, nor any act of acceptance by the AUTHORITY nor any failure to do so, nor any review and Approval of a Shop Drawing or sample submission, nor any correction of Defective Work by the AUTHORITY will constitute an acceptance of Work not in accordance with the Contract Documents or a release of the CONTRACTOR's obligation to perform the Work in accordance with the Contract Documents.

**13.17 Waiver of Claims by CONTRACTOR:**

The making and acceptance of final payment will constitute a waiver of all claims by the CONTRACTOR against the AUTHORITY other than those previously made in writing and still unsettled.

**13.18 No Waiver of Legal Rights:**

The AUTHORITY shall not be precluded or be estopped by any payment, measurement, estimate, or certificate made either before or after the completion and acceptance of the Work and payment therefore, from showing the true amount and character of the Work performed and materials furnished by the CONTRACTOR, nor from showing that any payment, measurement, estimate or certificate is untrue or is incorrectly made, or that the Work or materials are Defective. The AUTHORITY shall not be precluded or estopped, notwithstanding any such measurement, estimate, or certificate and payment in accordance therewith, from recovering from the CONTRACTOR or his Sureties, or both, such damages as it may sustain by reason of his failure to comply with requirements of the Contract Documents. Neither the acceptance by the AUTHORITY, or any representative of the AUTHORITY, nor any payment for or acceptance of the whole or any part of the Work, nor any extension of the Contract Time, nor any possession taken by the AUTHORITY, shall operate as a waiver of any portion of the Contract or of any power herein reserved, or of any

right to damages. A waiver by the AUTHORITY of any breach of the Contract shall not be held to be a waiver of any other subsequent breach.

## **ARTICLE 14 - SUSPENSION OF WORK, DEFAULT AND TERMINATION**

### **14.1 AUTHORITY May Suspend Work:**

14.1.1 The AUTHORITY may, at any time, suspend the Work or any portion thereof by notice in writing to the CONTRACTOR. If the Work is suspended without cause the CONTRACTOR shall be allowed an increase in the Contract Price or an extension of the Contract Time, or both, directly attributable to any suspension if the CONTRACTOR makes an Approved claim therefore as provided in Article 15. However, no adjustment shall be made under this clause for any suspension, delay, or interruption to the extent that suspension is due to the fault or negligence of the CONTRACTOR, or that suspension is necessary for Contract compliance, or that performance would have been so suspended, delayed, or interrupted by any other cause, including the fault or negligence of the CONTRACTOR.

14.1.2 In case of suspension of Work, the CONTRACTOR shall be responsible for preventing damage to or loss of any of the Work already performed and of all materials whether stored on or off the site or Approved remote storage sites.

### **14.2 Default of Contract:**

14.2.1 The Contracting Officer may give the contractor and his surety a written Notice to Cure Default if the contractor:

- a. fails to begin work in the time specified,
- b. fails to use sufficient resources to assure prompt completion of the work,
- c. performs the work unsuitably or neglect or refuse to remove and replace rejected materials or work,
- d. stops work,
- e. fails to resume stopped work after receiving notice to do so,
- f. becomes insolvent (except that if you declare bankruptcy, termination will be under Title 11 US Code 362 and/or 365. Your bankruptcy does not relieve the surety of any obligations to assume the Contract and complete the work in a timely manner.
- g. Allows any final judgment to stand against him unsatisfied for period of 60 days, or
- h. Makes an assignment for the benefit of creditors without the consent of the Contracting Officer, or
- i. Disregards Regulatory Requirements of any public body having jurisdiction, or
- j. Otherwise violates in any substantial way any provisions of the Contract Documents, or
- k. fails to comply with Contract minimum wage payments or civil rights requirements, or
- l. are party to fraud, deception, misrepresentation , or



- m. for any cause whatsoever, fails to carry on the Work in an acceptable manner.
- 14.2.2 The Notice to Cure Default will detail the conditions determined to be in default, the time within which to cure the default and may, in the Contracting Officer's discretion, specify the actions necessary to cure the default. Failure to cure the delay, neglect or default within the time specified in the Contracting Officer's written notice to cure authorizes the Authority to terminate the contract. The Contracting Officer may allow more time to cure than originally stated in the Notice to Cure Default if he deems it to be in the best interests of the Authority. The Authority will provide you and your surety with a written Notice of Default Termination that details the default and the failure to cure it.
- 14.2.3 If the CONTRACTOR or Surety, within the time specified in the above notice of default, shall not proceed in accordance therewith, then the AUTHORITY may, upon written notification from the Contracting Officer of the fact of such delay, neglect or default and the CONTRACTOR's failure to comply with such notice, have full power and authority without violating the Contract, to take the prosecution of the Work out of the hands of the CONTRACTOR. The AUTHORITY may terminate the services of the CONTRACTOR, exclude the CONTRACTOR from the site and take possession of the Work and of all the CONTRACTOR's tools, appliances, construction equipment and machinery at the site and use the same to the full extent they could be used by the CONTRACTOR (without liability to the CONTRACTOR for trespass or conversion), incorporate in the Work all materials and equipment stored at the site or for which the AUTHORITY has paid the CONTRACTOR but which are stored elsewhere, and finish the Work as the AUTHORITY may deem expedient. The AUTHORITY may enter into an agreement for the completion of said Contract according to the terms and provisions thereof, or use such other methods that in the opinion of the Contracting Officer are required for the completion of said Contract in an acceptable manner.
- 14.2.4 The Contracting Officer may, by written notice to the CONTRACTOR and his Surety or his representative, transfer the employment of the Work from the CONTRACTOR to the Surety, or if the CONTRACTOR abandons the Work undertaken under the Contract, the Contracting Officer may, at his option with written notice to the Surety and without any written notice to the CONTRACTOR, transfer the employment for said Work directly to the Surety. The Surety shall submit its plan for completion of the Work, including any contracts or agreements with third parties for such completion, to the AUTHORITY for Approval prior to beginning completion of the Work. Approval of such contracts shall be in accordance with all applicable requirements and procedures for Approval of subcontracts as stated in the Contract Documents.
- 14.2.5 After the notice of termination is issued, the Authority may take over the work and complete it by contract or otherwise and may take possession of and use materials, appliances, equipment or plant on the work site necessary for completing the work.
- 14.2.6 Rather than taking over the work itself, the Authority may transfer the obligation to perform the work from the contractor to your surety. The surety must submit its plan for completion of the work, including any contracts or agreements with third parties for completion, to the Authority for approval prior to beginning work. The surety must follow the Contract requirements for approval of subcontracts, except that the limitation on percent of work subcontracted will not apply.

- 14.2.7 On receipt of the transfer notice, the surety must take possession of all materials, tools, and appliances at the work site, employ an appropriate work force, and complete the Contract work, as specified. The Contract specifications and requirements shall remain in effect. However the Authority will make subsequent Contract payments directly to the Surety for work performed under the terms of the Contract. CONTRACTOR forfeits any right to claim for the same work or any part thereof. CONTRACTOR is not entitled to receive any further balance of the amount to be paid under the Contract.
- 14.2.8 Upon receipt of the notice terminating the services of the CONTRACTOR, the Surety shall enter upon the premises and take possession of all materials, tools, and appliances thereon for the purpose of completing the Work included under the Contract and employ by contract or otherwise any person or persons to finish the Work and provide the materials therefore, without termination of the continuing full force and effect of this Contract. In case of such transfer of employment to the Surety, the Surety shall be paid in its own name on estimates covering Work subsequently performed under the terms of the Contract and according to the terms thereof without any right of the CONTRACTOR to make any claim for the same or any part thereof.
- 14.2.9 If the Contract is terminated for default, the CONTRACTOR and the Surety shall be jointly and severally liable for damages for delay as provided by paragraph 11.8, and for the excess cost of completion, and all costs and expenses incurred by the AUTHORITY in completing the Work or arranging for completion of the Work, including but not limited to costs of assessing the Work to be done, costs associated with advertising, soliciting or negotiating for bids or proposals for completion, and other procurement costs. Following termination the CONTRACTOR shall not be entitled to receive any further balance of the amount to be paid under the Contract until the Work is fully finished and accepted, at which time if the unpaid balance exceeds the amount due the AUTHORITY and any amounts due to persons for whose benefit the AUTHORITY has withheld funds, such excess shall be paid by the AUTHORITY to the CONTRACTOR. If the damages, costs, and expenses due the AUTHORITY exceed the unpaid balance, the CONTRACTOR and his Surety shall pay the difference.
- 14.2.10 If, after notice of termination of the CONTRACTOR's right to proceed under the provisions of this clause, it is determined for any reason that the CONTRACTOR was not in default under the provisions of this clause, or that the delay was excusable under the provisions of this clause, or that termination was wrongful, the rights and obligations of the parties shall be determined in accordance with the clause providing for convenience termination.

### **14.3 Rights or Remedies:**

Where the CONTRACTOR's services have been so terminated by the AUTHORITY, the termination will not affect any rights or remedies of the AUTHORITY against the CONTRACTOR then existing or which may thereafter accrue. Any retention or payment of moneys due the CONTRACTOR by the AUTHORITY will not release the CONTRACTOR from liability.

### **14.4 Convenience Termination:**

14.4.1 The performance of the Work may be terminated by the AUTHORITY in

accordance with this section in whole or in part, whenever, for any reason the Contracting Officer shall determine that such termination is in the best interest of the OWNER. Any such termination shall be effected by delivery to the CONTRACTOR of a Notice of Termination, specifying termination is for the convenience of the AUTHORITY the extent to which performance of Work is terminated, and the date upon which such termination becomes effective.

14.4.2 Immediately upon receipt of a Notice of Termination and except as otherwise directed by the Contracting Officer, the CONTRACTOR shall:

- a. Stop Work on the date and to the extent specified in the Notice of Termination;
- b. Place no further orders or subcontracts for materials, services, or facilities except as may be necessary for completion of such portion of the Work as is not terminated;
- c. Terminate all orders and subcontracts to the extent that they relate to the performance of Work terminated by the Notice of Termination;
- d. With the written Approval of the Contracting Officer, to the extent he may require, settle all outstanding liabilities and all claims arising out of such termination of orders and subcontracts, the cost of which would be reimbursable, in whole, or in part, in accordance with the provisions of the Contract;
- e. Submit to the Contracting Officer a list, certified as to quantity and quality, of any or all items of termination inventory exclusive of items the disposition of which had been directed or authorized by the Contracting Officer;
- f. Transfer to the Contracting Officer the completed or partially completed record drawings, Shop Drawings, information, and other property which, if the Contract had been completed, would be required to be furnished to the AUTHORITY;
- g. Take such action as may be necessary, or as the Contracting Officer may direct, for the protection and preservation of the property related to the Contract which is in the possession of the CONTRACTOR and in which the AUTHORITY has or may acquire any interest.

The CONTRACTOR shall proceed immediately with the performance of the above obligations.

14.4.3 When the AUTHORITY orders termination of the Work effective on a certain date, all Work in place as of that date will be paid for in accordance with Article 13 of the Contract. Materials required for completion and on hand but not incorporated in the Work will be paid for at invoice cost plus 15 % with materials becoming the property of the AUTHORITY - or the CONTRACTOR may retain title to the materials and be paid an agreed upon lump sum. Materials on order shall be cancelled, and the AUTHORITY shall pay reasonable factory cancellation charges with the option of taking delivery of the materials in lieu of payment of cancellation charges. The CONTRACTOR shall be paid 10% of the cost, freight not included, of materials cancelled, and direct expenses only for CONTRACTOR chartered freight transport which cannot be cancelled without charges, to the extent that the CONTRACTOR can establish them. The extra costs due to cancellation of bonds and insurance and that part of job start-up and phase-out costs not amortized by the amount of Work accomplished shall be paid by the AUTHORITY. Charges for loss of profit or consequential damages shall not be recoverable except as provided above.

- a. The following costs are not payable under a termination settlement agreement or Contracting Officer's determination of the termination claim:
    1. Loss of anticipated profits or consequential or compensatory damages
    2. Unabsorbed home office overhead (also termed "General & Administrative Expense") related to ongoing business operations
    3. Bidding and project investigative costs
    4. Direct costs of repairing equipment to render it operable for use on the terminated work
- 14.4.4 The termination claim shall be submitted promptly, but in no event later than 90 days from the effective date of termination, unless extensions in writing are granted by the Contracting Officer upon written request of the CONTRACTOR made within the 90 day period. Upon failure of the CONTRACTOR to submit his termination claim within the time allowed, the Contracting Officer may determine, on the basis of information available to him, the amount, if any, due to the CONTRACTOR by reason of the termination and shall thereupon pay to the CONTRACTOR the amount so determined.
- 14.4.5 The CONTRACTOR and the Contracting Officer may agree upon whole or any part of the amount or amounts to be paid to the CONTRACTOR by reason of the total or partial termination of Work pursuant to this section. The Contract shall be amended accordingly, and the CONTRACTOR shall be paid the agreed amount.
- 14.4.6 In the event of the failure of the CONTRACTOR and the Contracting Officer to agree in whole or in part, as provided heretofore, as to the amounts with respect to costs to be paid to the CONTRACTOR in connection with the termination of the Work the Contracting Officer shall determine, on the basis of information available to him, the amount, if any, due to the CONTRACTOR by reason of the termination and shall pay to the CONTRACTOR the amount determined as follows:
- a. All costs and expenses reimbursable in accordance with the Contract not previously paid to the CONTRACTOR for the performance of the Work prior to the effective date of the Notice of Termination;
  - b. So far as not included under "a" above, the cost of settling and paying claims arising out of the termination of the Work under subcontracts or orders which are properly chargeable to the terminated portions of the Contract;
  - c. So far as practicable, claims by the contractor for idled or stand-by equipment shall be made as follows: Equipment claims will be reimbursed as follows:
    1. Contractor-owned equipment usage, based on the contractor's ownership and operating costs for each piece of equipment as determined from the contractor's accounting records. Under no circumstance, may the contractor base equipment claims on published rental rates.
    2. Idle or stand-by time for Contractor-owned equipment, based on your internal ownership and depreciation costs. Idle or stand-by equipment time is limited to the actual period of time equipment is idle or on stand-by as a direct result of the termination, not to exceed 30 days. Operating expenses will not be included for payment of idle or stand-by equipment

time.

3. Rented equipment, based on reasonable, actual rental costs. Equipment leased under "capital leases" as defined in Financial Accounting Standard No. 13 will be considered Contractor-owned equipment. Equipment leased from an affiliate, division, subsidiary or other organization under common control with you will be considered Contractor-owned equipment, unless the lessor has an established record of leasing to unaffiliated lessees at competitive rates consistent with the rates you have agreed to pay and no more than forty percent of the lessor's leasing business, measured in dollars, is with organizations affiliated with the lessor.

14.4.7 The CONTRACTOR shall have the right of appeal under the AUTHORITY's claim procedures, as defined in Article 15, for any determination made by the Contracting Officer, except if the CONTRACTOR has failed to submit his claim within the time provided and has failed to request extension of such time, CONTRACTOR shall have no such right of appeal. In arriving at the amount due the CONTRACTOR under this section, there shall be deducted:

- a. All previous payments made to the CONTRACTOR for the performance of Work under the Contract prior to termination;
- b. Any claim for which the AUTHORITY may have against the CONTRACTOR;
- c. The agreed price for, or the proceeds of sale of, any materials, supplies, or other things acquired by the CONTRACTOR or sold pursuant to the provisions of this section and not otherwise recovered by or credited to the AUTHORITY; and,
- d. All progress payments made to the CONTRACTOR under the provisions of this section.

14.4.8 Where the Work has been terminated by the AUTHORITY said termination shall not affect or terminate any of the rights of the AUTHORITY against the CONTRACTOR or his Surety then existing or which may thereafter accrue because of such default. Any retention or payment of monies by the AUTHORITY due to the CONTRACTOR under the terms of the Contract shall not release the CONTRACTOR or his Surety from liability.

14.4.9 The contractor's termination claim may not include claims that pre dated the notice for termination for convenience. Those claims shall be prosecuted by the contractor under Article 15.

14.4.10 The contractor's termination claim may not exceed the total dollar value of the contract as awarded plus agreed upon change orders less the amounts that have been paid for work completed.

- a. Unless otherwise provided for in the Contract Documents, or by applicable statute, the CONTRACTOR, from the effective date of termination and for a period of three years after final settlement under this Contract, shall preserve and make available to the AUTHORITY at all reasonable times at the office of the CONTRACTOR, all its books, records, documents, and other evidence bearing on the cost and expenses of the CONTRACTOR under his Contract and relating to the Work terminated hereunder.
- b. Cost Principles. The Authority may use the federal cost principles at 48 CFR §§ 31.201-1 to 31.205-52 (or succeeding cost principles for fixed price contracts) as guidelines in determining allowable costs under this

Subsection to the extent they are applicable to construction contracts and consistent with the specifications of this Contract. The provisions of this contract control where they are more restrictive than, or inconsistent with, these federal cost principles.”

## **ARTICLE 15 - CLAIMS AND DISPUTES**

### **15.1 Notification**

- 15.1.1 The CONTRACTOR shall notify the AUTHORITY in writing as soon as the CONTRACTOR becomes aware of any act or occurrence which may form the basis of a claim for additional compensation or an extension of Contract Time or of any dispute regarding a question of fact or interpretation of the Contract. The AUTHORITY has no obligation to investigate any fact or occurrence that might form the basis of a claim or to provide any additional compensation or extension of Contract Time unless the CONTRACTOR has notified the AUTHORITY in writing in a timely manner of all facts the CONTRACTOR believes form the basis for the claim.
- 15.1.2 If the CONTRACTOR believes that he is entitled to an extension of Contract Time, then the CONTRACTOR must state the contract section on which he basis his extension request, provide the AUTHORITY with sufficient information to demonstrate that the CONTRACTOR has suffered excusable delay, and show the specific amount of time to which the CONTRACTOR is entitled. The AUTHORITY will not grant an extension of Contract Time if the CONTRACTOR does not timely submit revised schedules under **Section 01300**.
- 15.1.3 If the matter is not resolved by agreement within 7 days, the CONTRACTOR shall submit an Intent to Claim, in writing, to the AUTHORITY within the next 14 days.
- 15.1.4 If the CONTRACTOR believes additional compensation or time is warranted, then he must immediately begin keeping complete, accurate, and specific daily records concerning every detail of the potential claim including actual costs incurred. The CONTRACTOR shall provide the AUTHORITY access to any such records and furnish the AUTHORITY copies, if requested. Equipment costs must be based on the CONTRACTOR's internal rates for ownership, depreciation, and operating expenses and not on published rental rates. In computing damages, or costs claimed for a change order, or for any other claim against the Authority for additional time, compensation or both, the contractor must prove actual damages based on internal costs for equipment, labor or efficiencies. Total cost, modified total cost or jury verdict forms of presentation of damage claims are not permissible to show damages. Labor inefficiencies must be shown to actually have occurred and can be proven solely based on job records. Theoretical studies are not a permissible means of showing labor inefficiencies. Home office overhead will not be allowed as a component of any claim against the Authority.
- 15.1.5 If the claim or dispute is not resolved by the Project Manager, then the CONTRACTOR shall submit a written Claim to the Contracting Officer within 90 days after the CONTRACTOR becomes aware of the basis of the claim or should have known the basis of the claim, whichever is earlier. The Contracting Officer will issue written acknowledge of the receipt of the Claim.
- 15.1.6 The CONTRACTOR waives any right to claim if the AUTHORITY was not notified properly or afforded the opportunity to inspect conditions or monitor actual costs or if the Claim is not filed on the date required.

### **15.2 Presenting the Claim**

- 15.2.1 The Claim must include all of the following:

- a. The act, event, or condition the claim is based on
- b. The Contract provisions which apply to the claim and provide relief
- c. The item or items of Contract work affected and how they are affected
- d. The specific relief requested, including Contract Time if applicable, and the basis upon which it was calculated
- e. A statement certifying that the claim is made in good faith, that the supporting cost and pricing data are accurate and complete to the best of your knowledge and belief, and that the amount requested accurately reflects the Contract adjustment which the CONTRACTOR believes is due.

### **15.3 Claim Validity, Additional Information, and AUTHORITY's Action**

- 15.3.1 The Claim, in order to be valid, must not only show that the CONTRACTOR suffered damages or delay but that it was caused by the act, event, or condition complained of and that the Contract provides entitlement to relief for such act, event, or condition.
- 15.3.2 The AUTHORITY can make written request to the CONTRACTOR at any time for additional information relative to the Claim. The CONTRACTOR shall provide the AUTHORITY the additional information within 30 days of receipt of such a request. Failure to furnish the additional information may be regarded as a waiver of the Claim.

### **15.4 Contracting Officer's Decision**

- 15.4.1 The CONTRACTOR will be furnished the Contracting Officer's Decision within 90 days, unless the Contracting Officer requests additional information or gives the CONTRACTOR notice that the time for issuing a decision is being extended for a specified period. The Contracting Officer's decision is final and conclusive unless, within 14 days of receipt of the decision, the CONTRACTOR delivers a Notice of Appeal to the Executive Director of the Authority.

### **15.5 Appeals on a Contract Claim.**

- 15.5.1 An appeal from a decision of the Contracting Officer on a contract claim may be filed by the CONTRACTOR with the Executive Director of the Authority. The appeal shall be filed within 14 days after the decision is received by the CONTRACTOR. An appeal by the CONTRACTOR may not raise any new factual issues or theories of recovery that were not presented to and decided by the Contracting Officer in the decision under Section 15.4, except that a CONTRACTOR may increase the contractor's calculation of damages if the increase arises out of the same operative facts on which the original claim was based. The CONTRACTOR shall file a copy of the appeal with the Contracting Officer.
  - a. An appeal must contain a copy of the decision being appealed and identification of the factual or legal errors in the decision that form the basis for the appeal.
  - b. The Executive Director shall handle the appeal of a claim under this section expeditiously.

### **15.6 Construction Contract Claim Appeals.**



**15.6.1 The appeal from a decision of the Contracting Officer of a claim involving a construction contract shall be resolved by:**

- a. binding and final arbitration under AS 09.43.010 - 09.43.180 (Uniform Arbitration Act) if the claim is:
  - 1. less than \$250,000 and the CONTRACTOR requests arbitration of the claim; or
  - 2. \$250,000 or more and both the agency and the CONTRACTOR agree to arbitration of the claim; or
- b. a hearing under the Authority's established policy and procedures if the claim is not handled by arbitration under 15.6.1 of this subsection.

**15.7 Fraud and Misrepresentation in Making Claims**

Criminal and Civil penalties authorized under State or federal law (including, but not limited to, forfeiture of all claimed amounts) may be imposed on the CONTRACTOR if the CONTRACTOR makes or uses a misrepresentation in support of a claim or defraud or attempt to defraud the AUTHORITY at any stage of prosecuting a claim under this Contract.”

This page is blank intentionally.

**SECTION 00800  
SUPPLEMENTARY CONDITIONS  
MODIFICATIONS TO THE GENERAL CONDITIONS**

The following supplements modify, change, delete from, or add to Section 00700 "General Conditions of the Construction Contract for Buildings", revised December, 2011. Where any article of the General Conditions is modified, or a Paragraph, Subparagraph, or Clause thereof is modified or deleted by these Supplementary Conditions, the unaltered provisions of that Article, Paragraph, Subparagraph, or Clause shall remain in effect

**00800.1-CONTRACT TIME / MILESTONES**

- December 2016 Anticipated Contract award
- January 2, 2017 Work Begins
- April 15, 2017 Kake Module Complete
- June 15, 2017 Kipnuk Module Complete
- June 30, 2017 Contractor Release

**SC-1-DEFINITIONS**

Add the following definitions:

**OWNER** – Native Village of Kipnuk and Kake.  
**AUTHORITY** - The Alaska Energy Authority.

**SC-6.13 – SUBCONTRACTORS**

Add new general conditions Article 6.13.7 as follows:

“6.13.7 The Contractor may, without penalty, replace a subcontractor who:

1. Fails to comply with the licensing and registration requirements of AS 08.18;
2. Fails to obtain or maintain a valid Alaska Business License;
3. Files for bankruptcy or becomes insolvent;
4. Fails to execute a subcontract or performance of the work for which the subcontractor was listed, and the Contractor has acted in good faith;
5. Fails to obtain bonding acceptable to the AUTHORITY;
6. Fails to obtain insurance acceptable to the AUTHORITY;
7. Fails to perform subcontract work for which the subcontractor was listed;
8. Must be replaced to meet the Contractor’s required state or federal affirmative action requirements.
9. Refuses to agree to abide by the Contractor’s labor agreement; or
10. Is determined by the AUTHORITY to be not responsible.

In addition to the circumstances described above, a Contractor may in writing request permission from the AUTHORITY to add a new subcontractor or replace a listed subcontractor. The AUTHORITY will approve

the request if it determines in writing that allowing the addition or replacement is in the best interest of the state.

The Contractor shall submit a written request to add a new Subcontractor or replace a listed Subcontractor to the Contracting Officer a minimum of five working days prior to the date the new Subcontractor is scheduled to begin work on the construction site. The request must state the basis for the request and include supporting documentation acceptable to the Contracting Officer.

If a Contractor violates this article, the Contracting Officer may:

1. Cancel the Contract after Award without any damages accruing to the AUTHORITY; or
2. After notice and hearing, assess a penalty on the bidder in an amount not exceeding 10 percent of the value of the subcontract at issue.

**REQUIRED CONTRACT PROVISIONS**  
**For**  
**FEDERAL-AID CONSTRUCTION CONTRACTS**

- I. General
- II. Non-discrimination
- III. Non-segregated Facilities<sup>3</sup>
- IV. Payment of Predetermined Minimum Wages
- V. Statements and Payrolls
- VI. Record of Materials, Supplies, and Labor
- VII. Subletting or Assigning the Contract
- VIII. Safety: Accident Prevention
- IX. False Statements
- X. Implementation of Clean Air Act and Federal Water Pollution Control Act
- XI. Certification Regarding Debarment, Suspension, Ineligibility, and Voluntary Exclusion
- XII. Certification Regarding Use of Contract Funds for Lobbying

**I. GENERAL**

1. These contract provisions shall apply to all work performed on the contract by the Contractor's own organization and with the assistance of workers under the contractor's immediate superintendence and to all work performed on the contract by piecework, station work, or by subcontract.

2. Except as otherwise provided for in each section, the contractor shall insert in each subcontract all of the stipulations contained in these Required Contract Provisions and further require their inclusion in any lower tier subcontract or purchase order that may in turn be made. The Required Contract Provisions shall not be incorporated by reference in any case. The prime contractor shall be responsible for compliance by any subcontractor or lower tier subcontractor with these Required Contract Provisions.

3. A breach of any of the stipulations contained in these Required Contract Provisions shall be sufficient grounds for termination of the contract.

4. A breach of the following clauses of these Required Contract Provisions may also be grounds for debarment as provided in 29 CFR 5.12:

Section I, paragraph 2;  
Section IV, paragraphs 1, 2, 3, 4, and 7;  
Section V, paragraphs 1 and 2a through 2g.

5. Disputes arising out of the labor standards provisions of Section IV (except paragraph 5) and Section V of these Required Contract Provisions shall not be subject to the general disputes clause of this contract. Such disputes shall be resolved in accordance with the procedures of the U.S. Department of Labor (DOL) as set forth in 29 CFR 5, 6, and 7. Disputes within the meaning of this clause include disputes between the contractor (or any of its subcontractors) and the contracting agency, the DOL, or the contractor's employees or their representatives.

6. Selection of Labor: During the performance of this contract, the contractor shall not:

- a. discriminate against labor from any other State, possession, or territory of the United States, or
- b. Employ convict labor for any purpose within the limits of the project unless it is labor performed by convicts who are on parole, supervised release, or probation.

**II. NONDISCRIMINATION** (Applicable to all Federal-aid construction contracts and to all related subcontracts of \$10,000 or more.)

1. Equal Employment Opportunity: Equal employment opportunity (EEO) requirements not to discriminate and to take affirmative action to assure equal opportunity as set forth under laws, executive orders, rules, regulations (28 CFR 35, 29 CFR 1630 and 41 CFR 60) and orders of the Secretary of Labor as modified by the provisions prescribed herein, and imposed pursuant to 23 U.S.C. 140 shall constitute the EEO and specific affirmative action standards for the contractor's project activities under this contract. The Equal Opportunity Construction Contract Specifications set forth under 41 CFR 60-4.3 and the provisions of the American Disabilities Act of 1990 (42 U.S.C. 12101 et seq.) set forth under 28 CFR 35 and 29 CFR 1630 are incorporated by reference in this contract. In the execution of this contract, the contractor agrees to comply with the following minimum specific requirement activities of EEO:

a. The contractor will work with the Alaska Energy Authority (AEA) and the Federal Government in carrying out EEO obligations and in their review of his/her activities under the contract.

b. The contractor will accept as his operating policy the following statement:

"It is the policy of this Company to assure that applicants are employed, and that employees are treated during employment, without regard to their race, religion, sex, color, national origin, age or disability. Such action shall include: employment, upgrading, demotion, or transfer; recruitment or recruitment advertising; layoff or termination; rates of pay or other forms of compensation; and selection for training, including apprenticeship, pre-apprenticeship, and/or on-the-job training."

2. EEO Officer: The contractor will designate and make known to the AEA contracting officers an EEO Officer who will have the responsibility for and must be capable of effectively administering and promoting an active contractor program of EEO and who must be assigned adequate authority and responsibility to do so.

3. Dissemination of Policy: All members of the contractor's staff who are authorized to hire, supervise, promote, and discharge employees, or who recommend such action, or who are substantially involved in such action, will be made fully cognizant of, and will implement, the contractor's EEO policy and contractual responsibilities to provide EEO in each grade and classification of employment. To ensure that the above agreement will be met, the following actions will be taken as a minimum:

a. Periodic meetings of supervisory and personnel office employees will be conducted before the start of work and then not less often than once every six months, at which time the contractor's EEO policy and its implementation will be reviewed and explained. The meetings will be conducted by the EEO Officer.

b. All new supervisory or personnel office employees will be given a thorough indoctrination by the EEO Officer, covering all major aspects of the contractor's EEO obligations within thirty days following their reporting for duty with the contractor.

c. All personnel who are engaged in direct recruitment for the project will be instructed by the EEO Officer in the contractor's procedures for locating and hiring minority group employees.

d. Notices and posters setting forth the contractor's EEO policy will be placed in areas readily accessible to employees, applicants for employment and potential employees.

e. The contractor's EEO policy and the procedures to implement such policy will be brought to the attention of employees by means of meetings, employee handbooks, or other appropriate means.

4. Recruitment: When advertising for employees, the contractor will include in all advertisements for employees the notation: "An Equal Opportunity Employer." All such advertisements will be placed in publications having a large circulation among minority groups in the area from which the project work force would normally be derived.

a. The contractor will, unless precluded by a valid bargaining agreement, conduct systematic and direct recruitment through public and private employee referral sources likely to yield qualified minority group applicants. To meet this requirement, the contractor will identify sources of potential minority group employees, and establish with such identified sources procedures whereby minority group applicants may be referred to the contractor for employment consideration.

b. In the event the contractor has a valid bargaining agreement providing for exclusive hiring hall referrals, he is expected to observe the provisions of that agreement to the extent that the system permits the contractor's compliance with EEO contract provisions. (The DOL has held that where implementation of such agreements has the effect of discriminating against minorities or women, or obligates the contractor to do the same, such implementation violates Executive Order 11246, as amended.)

c. The contractor will encourage his present employees to refer minority group applicants for employment. Information and procedures with regard to referring minority group applicants will be discussed with employees.

5. Personnel Actions: Wages, working conditions, and employee benefits shall be established and administered, and personnel actions of every type, including hiring, upgrading, promotion, transfer, demotion, layoff, and termination, shall be taken without regard to race, color, religion, sex, national origin, age or disability. The following procedures shall be followed:

a. The contractor will conduct periodic inspections of project sites to insure that working conditions and employee facilities do not indicate discriminatory treatment of project site personnel.

b. The contractor will periodically evaluate the spread of wages paid within each classification to determine any evidence of discriminatory wage practices.

c. The contractor will periodically review selected personnel actions in depth to determine whether there is evidence of discrimination. Where evidence is found, the contractor will promptly take corrective action. If the review indicates that the discrimination may extend beyond the actions reviewed, such corrective action shall include all affected persons.

d. The contractor will promptly investigate all complaints of alleged discrimination made to the contractor in connection with his obligations under this contract, will attempt to resolve such complaints, and will take appropriate corrective action within a reasonable time. If the investigation indicates that the discrimination may affect persons other than the complainant, such corrective action shall include such other persons. Upon completion of each investigation, the contractor will inform every complainant of all of his avenues of appeal.

6. Training and Promotion:

a. The contractor will assist in locating, qualifying, and increasing the skills of minority group and women employees, and applicants for employment.

b. Consistent with the contractor's work force requirements and as permissible under Federal and State regulations, the contractor shall make full use of training programs, i.e., apprenticeship, and on-the-job training programs for the geographical area of contract performance. Where feasible, 25 percent of apprentices or trainees in each occupation shall be in their first year of apprenticeship or training. In the event a special provision for training is provided under this contract, this subparagraph will be superseded as indicated in the special provision.

c. The contractor will advise employees and applicants for employment of available training programs and entrance requirements for each.

d. The contractor will periodically review the training and promotion potential of minority group and women employees and will encourage eligible employees to apply for such training and promotion.

7. Unions: If the contractor relies in whole or in part upon unions as a source of employees, the contractor will use his/her best efforts to obtain the cooperation of such unions to increase opportunities for minority groups and women within the unions, and to effect referrals by such unions of minority and female employees. Actions by the contractor either directly or through a contractor's association acting as agent will include the procedures set forth below:

a. The contractor will use best efforts to develop, in cooperation with the unions, joint training programs aimed toward qualifying more minority group members and women for membership in the unions and increasing the skills of minority group employees and women so that they may qualify for higher paying employment.

b. The contractor will use best efforts to incorporate an EEO clause into each union agreement to the end that such union will be contractually bound to refer applicants without regard to their race, color, religion, sex, national origin, age or disability.

c. The contractor is to obtain information as to the referral practices and policies of the labor union except that to the extent such information is within the exclusive possession of the labor union and such labor union refuses to furnish such information to the contractor, the contractor shall so certify to the AEA and shall set forth what efforts have been made to obtain such information.

d. In the event the union is unable to provide the contractor with a reasonable flow of minority and women referrals within the time limit set forth in the collective bargaining agreement, the contractor will, through independent recruitment efforts, fill the employment vacancies without regard to race, color, religion, sex, national origin, age or disability; making full efforts to obtain qualified and/or qualifiable minority group persons and women. (The DOL has held that it shall be no excuse that the union with which the contractor has a collective bargaining agreement providing for exclusive referral failed to refer minority employees.) In the event the union referral practice prevents the contractor from meeting the obligations pursuant to Executive Order 11246, as amended, and these special provisions, such contractor shall immediately notify the AEA.

8. Selection of Subcontractors, Procurement of Materials, and Leasing of Equipment: The contractor shall not discriminate on the grounds of race, color, religion, sex, national origin, age or disability in the selection and retention of subcontractors, including procurement of materials and leases of equipment.

a. The contractor shall notify all potential subcontractors and suppliers of his/her EEO obligations under this contract.

b. Disadvantaged business enterprises (DBE), as defined in 49 CFR 26 shall have equal opportunity to compete for and perform subcontracts which the contractor enters into pursuant to this contract. The contractor will use his best efforts to solicit bids from and to utilize DBE subcontractors or subcontractors with meaningful minority group and female representation among their employees. Contractors shall obtain lists of DBE construction firms from AEA personnel.

c. The contractor will use his best efforts to ensure subcontractor compliance with their EEO obligations.

9. Records and Reports: The contractor shall keep such records as necessary to document compliance with the EEO requirements. Such records shall be retained for a period of three years



following completion of the contract work and shall be available at reasonable times and places for inspection by authorized representatives of the AEA and the U.S. DOT.

a. The records kept by the contractor shall document the following:

(1) The number of minority and non-minority group members and women employed in each work classification on the project;

(2) The progress and efforts being made in cooperation with unions, when applicable, to increase employment opportunities for minorities and women;

(3) The progress and efforts being made in locating, hiring, training, qualifying, and upgrading minority and female employees; and

(4) The progress and efforts being made in securing the services of DBE subcontractors or subcontractors with meaningful minority and female representation among their employees.

b. The contractors will submit an annual report to the AEA each July for the duration of the project, indicating the number of minority, women, and non minority group employees currently engaged in each work classification required by the contract work. This information is to be reported on Form FHWA-1391. If on the job training is being required by special provision, the contractor will be required to collect and report training data.

**III. NONSEGREGATED FACILITIES** (Applicable to all Federal-aid construction contracts and to all related subcontracts of \$10,000 or more.)

1. By submission of this bid, the execution of this contract or subcontract, or the consummation of this material supply agreement or purchase order, as appropriate, the bidder, Federal-aid construction contractor, subcontractor, material supplier, or vendor, as appropriate, certifies that the firm does not maintain or provide for its employees any segregated facilities at any of its establishments, and that the firm does not permit its employees to perform their services at any location, under its control, where segregated facilities are maintained. The firm agrees that a breach of this certification is a violation of the EEO Provisions of this contract. The firm further certifies that no employee will be denied access to adequate facilities on the basis of sex or disability.

2. As used in this certification, the term "segregated facilities" means any waiting rooms, work areas, restrooms and washrooms, restaurants and other eating areas, timeclocks, locker rooms and other storage or dressing areas, parking lots, drinking fountains, recreation or entertainment areas, transportation, and housing facilities provided for employees which are segregated by explicit directive, or are, in fact, segregated on the basis of race, color, religion, or national origin, age or disability, because of habit, local custom, or otherwise. The only exception will be for the disabled when the demands for accessibility override (e.g. disabled parking).

3. The contractor agrees that it has obtained or will obtain identical certification from proposed subcontractors or material suppliers prior to the award of subcontracts or consummation of material supply agreements of \$10,000 or more and that it will retain such certifications in its files.

**IV. PAYMENT OF PREDETERMINED MINIMUM WAGES** (Applicable to all Federal-aid construction contracts exceeding \$2,000 and to all related subcontracts, except for projects located on roadways classified as local roads or rural minor collectors, which are exempt.)

1. General:

a. All mechanics and laborers employed or working upon the site of the work will be paid unconditionally and not less often than once a week, and without subsequent deduction or rebate on

any account [except such payroll deductions as are permitted by regulations (29 CFR 3) issued by the Secretary of Labor under the Copeland Act (40 U.S.C. 276c] the full amounts of wages and bona fide fringe benefits (or cash equivalents thereof) due at time of payment. The payment shall be computed at wage rates not less than those contained in the wage determination of the Secretary of Labor (hereinafter "the wage determination") which is attached hereto and made a part hereof, regardless of any contractual relationship which may be alleged to exist between the contractor or its subcontractors and such laborers and mechanics. The wage determination (including any additional classifications and wage rates conformed under paragraph 2 of this Section IV and the DOL poster (WH-1321) or Form FHWA-1495) shall be posted at all times by the contractor and its subcontractors at the site of the work in a prominent and accessible place where it can be easily seen by the workers. For the purpose of this Section, contributions made or costs reasonably anticipated for bona fide fringe benefits under section 1(b)(2) of the Davis-Bacon Act (40 U.S.C. 276a) on behalf of laborers or mechanics are considered wages paid to such laborers or mechanics, subject to the provisions of Section IV, paragraph 3b, hereof. Also for the purpose of this Section, regular contributions made or costs incurred for more than a weekly period (but not less often than quarterly) under plans, funds, or programs, which cover the particular weekly period, are deemed to be constructively made or incurred during such weekly period. Such laborers and mechanics shall be paid the appropriate wage rate and fringe benefits on the wage determination for the classification of work actually performed, without regard to skill, except as provided in paragraphs 4 and 5 of this Section IV.

b. Laborers or mechanics performing work in more than one classification may be compensated at the rate specified for each classification for the time actually worked therein, provided, that the employer's payroll records accurately set forth the time spent in each classification in which work is performed.

c. All rulings and interpretations of the Davis-Bacon and related acts contained in 29 CFR 1, 3, and 5 are herein incorporated by reference in this contract.

## 2. Classification:

a. The AEA contracting officer shall require that any class of laborers or mechanics employed under the contract, which is not listed in the wage determination, shall be classified in conformance with the wage determination.

b. The contracting officer shall approve an additional classification, wage rate and fringe benefits only when the following criteria have been met:

(1) The work to be performed by the additional classification requested is not performed by a classification in the wage determination;

(2) The additional classification is utilized in the area by the construction industry;

(3) The proposed wage rate, including any bona fide fringe benefits, bears a reasonable relationship to the wage rates contained in the wage determination; and

(4) With respect to helpers, when such a classification prevails in the area in which the work is performed.

c. If the contractor or subcontractors, as appropriate, the laborers and mechanics (if known) to be employed in the additional classification or their representatives, and the contracting officer agree on the classification and wage rate (including the amount designated for fringe benefits where appropriate), a report of the action taken shall be sent by the contracting officer to the U.S. Department of Labor, Administrator of the Wage and Hour Division, Employment Standards Administration, Washington, D.C. 20210. The Wage and Hour Administrator, or an authorized representative, will approve, modify, or disapprove every additional classification action within 30 days

of receipt and so advise the contracting officer or will notify the contracting officer within the 30-day period that additional time is necessary.

d. In the event the contractor or subcontractors, as appropriate, the laborers or mechanics to be employed in the additional classification or their representatives, and the contracting officer do not agree on the proposed classification and wage rate (including the amount designated for fringe benefits, where appropriate), the contracting officer shall refer the questions, including the views of all interested parties and the recommendation of the contracting officer, to the Wage and Hour Administrator for determination. Said Administrator, or an authorized representative, will issue a determination within 30 days of receipt and so advise the contracting officer or will notify the contracting officer within the 30-day period that additional time is necessary.

e. The wage rate (including fringe benefits where appropriate) determined pursuant to paragraph 2c or 2d of this Section IV shall be paid to all workers performing work in the additional classification from the first day on which work is performed in the classification.

### 3. Payment of Fringe Benefits:

a. Whenever the minimum wage rate prescribed in the contract for a class of laborers or mechanics includes a fringe benefit which is not expressed as an hourly rate, the contractor or subcontractors, as appropriate shall either pay the benefit as stated in the wage determination or shall pay another bona fide fringe benefit or an hourly cash equivalent thereof.

b. If the contractor or subcontractor, as appropriate, does not make payments to a trustee or other third person, he/she may consider as part of the wages of any laborer or mechanic the amount of any costs reasonably anticipated in providing bona fide fringe benefits under a plan or program, provided that the Secretary of Labor has found, upon the written request of the contractor, that the applicable standards of the Davis-Bacon Act have been met. The Secretary of Labor may require the contractor to set aside in a separate account assets for the meeting of obligations under the plan or program.

### 4. Apprentices and Trainees (Programs of the U. S. DOL) and Helpers:

#### a. Apprentices:

(1) Apprentices will be permitted to work at less than the predetermined rate for the work they performed when they are employed pursuant to and individually registered in a bona fide apprenticeship program registered with the DOL, Employment and Training Administration, Bureau of Apprenticeship and Training, or with a State apprenticeship agency recognized by the Bureau, or if a person is employed in his/her first 90 days of probationary employment as an apprentice in such an apprenticeship program, who is not individually registered in the program, but who has been certified by the Bureau of Apprenticeship and Training or a State apprenticeship agency (where appropriate) to be eligible for probationary employment as an apprentice.

(2) The allowable ratio of apprentices to journeyman-level employees on the job site in any craft classification shall not be greater than the ratio permitted to the contractor as to the entire work force under the registered program. Any employee listed on a payroll at an apprentice wage rate, who is not registered or otherwise employed as stated above, shall be paid not less than the applicable wage rate listed in the wage determination for the classification of work actually performed. In addition, any apprentice performing work on the job site in excess of the ratio permitted under the registered program shall be paid not less than the applicable wage rate on the wage determination for the work actually performed. Where a contractor or subcontractor is performing construction on a project in a locality other than that in which its program is registered, the ratios and wage rates (expressed in percentages of the journeyman-level hourly rate) specified in the contractor's or subcontractor's registered program shall be observed.

(3) Every apprentice must be paid at not less than the rate specified in the registered program for the apprentice's level of progress, expressed as a percentage of the journeyman-level hourly rate specified in the applicable wage determination. Apprentices shall be paid fringe benefits in accordance with the provisions of the apprenticeship program. If the apprenticeship program does not specify fringe benefits, apprentices must be paid the full amount of fringe benefits listed on the wage determination for the applicable classification. If the Administrator for the Wage and Hour Division determines that a different practice prevails for the applicable apprentice classification, fringes shall be paid in accordance with that determination.

(4) In the event the Bureau of Apprenticeship and Training, or a State apprenticeship agency recognized by the Bureau, withdraws approval of an apprenticeship program, the contractor or subcontractor will no longer be permitted to utilize apprentices at less than the applicable predetermined rate for the comparable work performed by regular employees until an acceptable program is approved.

b. Trainees:

(1) Except as provided in 29 CFR 5.16, trainees will not be permitted to work at less than the predetermined rate for the work performed unless they are employed pursuant to and individually registered in a program which has received prior approval, evidenced by formal certification by the DOL, Employment and Training Administration.

(2) The ratio of trainees to journeyman-level employees on the job site shall not be greater than permitted under the plan approved by the Employment and Training Administration. Any employee listed on the payroll at a trainee rate that is not registered and participating in a training plan approved by the Employment and Training Administration shall be paid not less than the applicable wage rate on the wage determination for the classification of work actually performed. In addition, any trainee performing work on the job site in excess of the ratio permitted under the registered program shall be paid not less than the applicable wage rate on the wage determination for the work actually performed.

(3) Every trainee must be paid at not less than the rate specified in the approved program for his/her level of progress, expressed as a percentage of the journeyman-level hourly rate specified in the applicable wage determination. Trainees shall be paid fringe benefits in accordance with the provisions of the trainee program. If the trainee program does not mention fringe benefits, trainees shall be paid the full amount of fringe benefits listed on the wage determination unless the Administrator of the Wage and Hour Division determines that there is an apprenticeship program associated with the corresponding journeyman-level wage rate on the wage determination which provides for less than full fringe benefits for apprentices, in which case such trainees shall receive the same fringe benefits as apprentices.

(4) In the event the Employment and Training Administration withdraws approval of a training program, the contractor or subcontractor will no longer be permitted to utilize trainees at less than the applicable predetermined rate for the work performed until an acceptable program is approved.

c. Helpers: Helpers will be permitted to work on a project if the helper classification is specified and defined on the applicable wage determination or is approved pursuant to the conformance procedure set forth in Section IV.2. Any worker listed on a payroll at a helper wage rate, which is not a helper under an approved definition, shall be paid not less than the applicable wage rate on the wage determination for the classification of work actually performed.

5. Apprentices and Trainees (Programs of the U.S. DOT): Apprentices and trainees working under apprenticeship and skill training programs which have been certified by the Secretary of Transportation as promoting EEO in connection with Federal-aid highway construction programs are not subject to the requirements of paragraph 4 of this Section IV. The straight time hourly wage rates for apprentices and

trainees under such programs will be established by the particular programs. The ratio of apprentices and trainees to journeymen shall not be greater than permitted by the terms of the particular program.

6. **Withholding:** The AEA shall, upon its own action or upon written request of an authorized representative of the DOL, withhold or cause to be withheld from the contractor or subcontractor under this contract or any other Federal contract with the same prime contractor, or any other Federally-assisted contract subject to Davis-Bacon prevailing wage requirements, which is held by the same prime contractor, as much of the accrued payments or advances as may be considered necessary to pay laborers and mechanics, including apprentices, trainees, and helpers employed by the contractor or any subcontractor the full amount of wages required by the contract. In the event of failure to pay any laborer or mechanic, including any apprentice, trainee, or helper, employed or working on the site of the work, all or part of the wages required by the contract, the AEA Procurement Officer may, after written notice to the contractor, take such action as may be necessary to cause the suspension of any further payment, advance, or guarantee of funds until such violations have ceased.

7. **Overtime Requirements:** No contractor or subcontractor contracting for any part of the contract work which may require or involve the employment of laborers, mechanics, watchmen, or guards (including apprentices, trainees, and helpers described in paragraphs 4 and 5 above) shall require or permit any laborer, mechanic, watchman, or guard in any workweek in which he/she is employed on such work, to work in excess of 40 hours in such work week unless such laborer, mechanic, watchman, or guard receives compensation at a rate not less than one-and-one-half times his/her basic rate of pay for all hours worked in excess of 40 hours in such workweek.

8. **Violation: Liability for Unpaid Wages; Liquidated Damages:** In the event of any violation of the clause set forth in paragraph 7 above, the contractor and any subcontractor responsible therefor shall be liable to the affected employee for his/her unpaid wages. In addition, such contractor and subcontractor shall be liable to the United States for liquidated damages. Such liquidated damages shall be computed with respect to each individual laborer, mechanic, watchman, or guard employed in violation of the clause set forth in paragraph 7, in the sum of \$10 for each calendar day on which such employee was required or permitted to work in excess of the standard workweek of 40 hours without payment of the overtime wages required by the clause set forth in paragraph 7.

9. **Withholding for Unpaid Wages and Liquidated Damages:** The AEA shall, upon its own action or upon written request of an authorized representative of the U.S. Department of Labor, withhold or cause to be withheld from any monies payable on account of work performed by the contractor or subcontractor under any such contract or any other Federal contract with the same prime contractor, or any other Federally-assisted contract subject to the Contract Work Hours and Safety Standards Act, which is held by the same prime contractor, such sums as may be determined to be necessary to satisfy any liabilities of such contractor or subcontractor for unpaid wages and liquidated damages as provided in the clause set forth in paragraph 8 above.

**V. STATEMENTS AND PAYROLLS** (Applicable to all Federal-aid construction contracts exceeding \$2,000 and to all related subcontracts, except for projects located on roadways classified as local roads or rural collectors, which are exempt.)

1. **Compliance with Copeland Regulations (29 CFR 3):** The contractor shall comply with the Copeland Regulations of the Secretary of Labor which are herein incorporated by reference.

2. **Payrolls and Payroll Records:**

a. Payrolls and basic records relating thereto shall be maintained by the contractor and each subcontractor during the course of the work and preserved for a period of 3 years from the date of completion of the contract for all laborers, mechanics, apprentices, trainees, watchmen, helpers, and guards working at the site of the work.

b. The payroll records shall contain the name, social security number, and address of each such employee, his or her correct classification, hourly rates of wages paid (including rates of contributions or costs anticipated for bona fide fringe benefits or cash equivalents thereof of the types described in Section 1(b) (2) (B) of the Davis-Bacon Act), daily and weekly number of hours worked, deductions made and actual wages paid. Whenever the Secretary of Labor, pursuant to Section IV, paragraph 3b, has found that the wages of any laborer or mechanic include the amount of any costs reasonably anticipated in providing benefits under a plan or program described in Section 1(b)(2)(B) of the Davis-Bacon Act, the contractor and each subcontractor shall maintain records which show that the commitment to provide such benefits is enforceable, that the plan or program is financially responsible, and that the plan or program has been communicated in writing to the laborers or mechanics affected, and records which show the cost anticipated or the actual cost incurred in providing benefits. Contractors or subcontractors employing apprentices or trainees under approved programs shall maintain written evidence of the registration of apprentices and trainees and ratios and wage rates prescribed in the applicable programs.

c. Each contractor and subcontractor shall furnish each week in which any contract work is performed a payroll of wages paid each of its employees (including apprentices, trainees, and helpers described in Section IV, paragraphs 4 and 5 and watchmen and guards engaged on work during the preceding weekly payroll period). The payroll submitted shall set out accurately and completely all of the information required to be maintained under paragraph 2b of this Section V. This information may be submitted in any form desired. Optional Form WH-347 is available for this purpose and may be purchased from the Superintendent of Documents (Federal stock number 029-005-0014-1), U.S. Government Printing Office, Washington, D.C. 20402 or the Government Bookstore, 915 Second Avenue, Seattle, WA 98174. The prime contractor is responsible for the submission of copies of payrolls by all subcontractors.

d. Each payroll submitted shall be accompanied by a "Statement of Compliance", signed by the contractor or subcontractor or his/her agent who pays or supervises the payment of the persons employed under the contract and shall certify the following:

(1) that the payroll for the payroll period contains the information required to be maintained under paragraph 2b of this Section V and that such information is correct and complete;

(2) that such laborer or mechanic (including each helper, apprentice, and trainee) employed on the contract during the payroll period has been paid in full weekly wages earned, without rebate, either directly or indirectly, and that no deductions have been made either directly or indirectly from the full wages earned, other than permissible deductions set forth in the Regulations, 29 CFR 3;

(3) That each laborer or mechanic has been paid not less than the applicable wage rate and fringe benefits or cash equivalents for the classification of work performed, as specified in the applicable wage determination incorporated into the contract.

e. The weekly submission of a properly executed certification set forth on the reverse side of Optional Form WH-347 shall satisfy the requirement for submission of the "Statement of Compliance" required by paragraph 2d of this Section V.

f. The falsification of any of the above certifications may subject the contractor to civil or criminal prosecution under 18 U.S.C. 1001 and 31 U.S.C. 231.

g. The contractor or subcontractor shall make the records required under paragraph 2b of this section V available for inspection, copying, or transcription by authorized representatives of the AEA, the U.S. DOT, or the DOL, and shall permit such representatives to interview employees during working hours on the job. If the contractor or subcontractor fails to submit the required records or to make them available, the AEA, the U.S. DOT, DOL, or all may, after written notice to the contractor, sponsor, applicant, or owner, take such actions as may be necessary to cause the suspension of any

further payment, advance, or guarantee of funds. Furthermore, failure to submit the required records upon request or to make such records available may be grounds for debarment action pursuant to 29 CFR 5.12.

## **VI. RECORDS OF MATERIALS, SUPPLIES, AND LABOR** (Applicable to highway contracts)

1. On all Federal-aid contracts on the National Highway System, except those which provide solely for the installation of protective devices at railroad grade crossings, those which are constructed on a force account or direct labor basis, highway beautification contracts, and contracts for which the total final construction cost for roadway and bridge is less than \$1,000,000 (23 CFR Part 635) the contractor shall:

a. Become familiar with the list of specific materials and supplies contained in Form FHWA-47, "Statement of Materials and Labor Used by Contractor of Highway Construction Involving Federal Funds," prior to the commencement of work under this contract.

b. Maintain a record of the total cost of all materials and supplies purchased for and incorporated in the work, and also of the quantities of those specific materials and supplies listed on Form FHWA-47, and in the units shown on the Form FHWA-47.

c. Furnish, upon the completion of the contract, to the AEA resident engineer on Form FHWA-47 together with the data required in paragraph 1b relative to materials and supplies, a final labor summary of all contract work indicating the total hours worked and the total amount earned.

2. At the prime contractor's option, either a single report covering all contract work or separate reports for the contractor and for each subcontract shall be submitted.

## **VII. SUBLETTING OR ASSIGNING THE CONTRACT**

1. The contractor shall perform with its own organization contract work amounting to not less than 30 percent (or a greater percentage if specified elsewhere in the contract) of the total original contract price, excluding any specialty items designated by the State. Specialty items may be performed by subcontract and the amount of any such specialty items so performed may be deducted from the total original contract price before computing the amount of work required to be performed by the contractor's own organization (23 CFR Part 635).

a. "Its own organization" shall be construed to include only workers employed and paid directly by the prime contractor and equipment owned or rented by the prime contractor, with or without operators. Such term does not include employees or equipment of a subcontractor, assignee, or agent of the prime contractor.

b. "Specialty Items" shall be construed to be limited to work that requires highly specialized knowledge, abilities, or equipment not ordinarily available in the type of contracting organizations qualified and expected to bid on the contract as a whole and in general are to be limited to minor components of the overall contract.

2. The contract amount upon which the requirements set forth in paragraph 1 of this Section VII is computed includes the cost of materials and manufactured products which are to be purchased or produced by the contractor under the contract provisions.

3. The contractor shall furnish (a) a competent superintendent or supervisor who is employed by the firm, has full authority to direct performance of the work in accordance with the contract requirements, and is in charge of all construction operations (regardless of who performs the work) and (b) such other of its own organizational resources (supervision, management, and engineering services) as the AEA contracting officer determines is necessary to assure the performance of the contract.

4. No portion of the contract shall be sublet, assigned or otherwise disposed of except with the written consent of the AEA contracting officer, or authorized representative, and such consent when given shall not be construed to relieve the contractor of any responsibility for the fulfillment of the contract. Written consent will be given only after the AEA is assured that each subcontract is evidenced in writing and that it contains all pertinent provisions and requirements of the prime contract.

## **VIII. SAFETY: ACCIDENT PREVENTION**

1. In the performance of this contract, the contractor shall comply with all applicable Federal, State, and local laws governing safety, health, and sanitation (23CFR 635). The contractor shall provide all safeguards, safety devices and protective equipment and take any other needed actions as it determines, or as the AEA contracting officer may determine, to be reasonably necessary to protect the life and health of employees on the job and the safety of the public and to protect property in connection with the performance of the work covered by the contract.

2. It is a condition of this contract, and shall be made a condition of each subcontract entered into pursuant to this contract, that the contractor and any subcontractor shall not permit any employee in performance of the contract, to work in surroundings or under conditions which are unsanitary, hazardous, or dangerous to his/her health or safety, as determined under construction safety and health standards (29 CFR 1926) promulgated by the Secretary of Labor, in accordance with Section 107 of the Contract Work Hours and Safety Standards Act (40 U.S.C. 333).

3. Pursuant to 29 CFR 1926.3, it is a condition of this contract that the Secretary of Labor or authorized representative thereof, shall have right of entry to any site of contract performance to inspect or investigate the matter of compliance with the construction safety and health standards and to carry out the duties of the Secretary under Section 107 of the Contract Work Hours and Safety Standards Act (40 U.S.C. 333).

## **IX. FALSE STATEMENTS**

In order to assure high quality and durable construction in conformity with approved plans and specifications and a high degree of reliability on statements and representations made by engineers, contractors, suppliers, and workers on Federal-aid projects, it is essential that all persons concerned with the project perform their functions as carefully, thoroughly, and honestly as possible. Willful falsification, distortion, or misrepresentation with respect to any facts related to the project is a violation of Federal law. Title 18, United States Code, Section 1001, states:

“Whoever, in any matter within the jurisdiction of any department or agency of the United States knowingly and willfully falsifies, conceals or covers up by any trick, scheme, or device a material fact, or makes any false, fictitious or fraudulent statements or representations, or makes or uses any false writing or document knowing the same to contain any false, fictitious or fraudulent statement or entry, shall be fined not more than \$10,000 or imprisoned not more than five years, or both.” (June 25, 1948, ch. 645, 62 Stat. 749.)

To prevent any misunderstanding regarding the seriousness of these and similar acts, the following notice shall be posted on each Federal-aid highway project (23 CFR 635) in one or more places where it is readily available to all personnel concerned with the project:

## **X. IMPLEMENTATION OF CLEAN AIR ACT AND FEDERAL WATER POLLUTION CONTROL ACT** (Applicable to all Federal-aid construction contracts and to all related subcontracts of \$100,000 or more.)

By submission of this bid, or the execution of this contract or subcontract, as appropriate, the bidder, Federal-aid construction contractor, or subcontractor, as appropriate, will be deemed to have stipulated as follows:



1. That any facility that is or will be utilized in the performance of this contract, unless such contract is exempt under the Clean Air Act, as amended (42 U.S.C. 1857 et seq., as amended by Pub. L. 91-604), and under the Federal Water Pollution Control Act, as amended (33 U.S.C. 1251, et seq., as amended by Pub. L. 92-500), Executive Order 11738, and regulations in implementation thereof (40 CFR Part 15) is not listed, on the date of contract award, on the U.S. Environmental Protection Agency (EPA) List of Violating Facilities pursuant to 40 CFR 15.20.
2. That the firm agrees to comply and remain in compliance with all the requirements of Section 114 of the Clean Air Act and Section 308 of the Federal Water Pollution Control Act and all regulations and guidelines listed thereunder.
3. That the firm shall promptly notify the AEA of the receipt of any communication from the Director, Office of Federal Activities, EPA, indicating that a facility that is or will be utilized for the contract is under consideration to be listed on the EPA List of Violating Facilities.
4. That the firm agrees to include or cause to be included the requirements of paragraphs 1 through 4 of this Section X in every nonexempt subcontract, and further agrees to take such action as the government may direct as a means of enforcing such requirements.

## **XI. CERTIFICATION REGARDING DEBARMENT, SUSPENSION, INELIGIBILITY AND VOLUNTARY EXCLUSION**

1. Instructions for Certification - Primary Covered Transactions: (Applicable to all Federal-aid contracts - 49 CFR 29)
  - a. By signing and submitting this proposal, the prospective primary participant is providing the certification set out below.
  - b. The inability of a person to provide the certification set out below will not necessarily result in denial of participation in this covered transaction. The prospective participant shall submit an explanation of why it cannot provide the certification set out below. The certification or explanation will be considered in connection with the department or agency's determination whether to enter into this transaction. However, failure of the prospective primary participant to furnish a certification or an explanation shall disqualify such a person from participation in this transaction.
  - c. The certification in this clause is a material representation of fact upon which reliance was placed when the department or agency determined to enter into this transaction. If it is later determined that the prospective primary participant knowingly rendered an erroneous certification, in addition to other remedies available to the Federal Government, the department or agency may terminate this transaction for cause of default.
  - d. The prospective primary participant shall provide immediate written notice to the department or agency to which this proposal is submitted if any time the prospective primary participant learns that its certification was erroneous when submitted or has become erroneous by reason of changed circumstances.
  - e. The terms "covered transaction," "debarred," "suspended," "ineligible," "lower tier covered transaction," "participant," "person," "primary covered transaction," "principal," "proposal," and "voluntarily excluded," as used in this clause, have the meanings set out in the Definitions and Coverage sections of rules implementing Executive Order 12549. You may contact the department or agency to which this proposal is submitted for assistance in obtaining a copy of those regulations.
  - f. The prospective primary participant agrees by submitting this proposal that, should the proposed covered transaction be entered into, it shall not knowingly enter into any lower tier covered transaction with a person who is debarred, suspended, declared ineligible, or voluntarily excluded from

participation in this covered transaction, unless authorized by the department or agency entering into this transaction.

g. The prospective primary participant further agrees by submitting this proposal that it will include the clause titled "Certification Regarding Debarment, Suspension, Ineligibility and Voluntary Exclusion-Lower Tier Covered Transaction," provided by the department or agency entering into this covered transaction, without modification, in all lower tier covered transactions and in all solicitations for lower tier covered transactions.

h. A participant in a covered transaction may rely upon a certification of a prospective participant in a lower tier covered transaction that is not debarred, suspended, ineligible, or voluntarily excluded from the covered transaction, unless it knows that the certification is erroneous. A participant may decide the method and frequency by which it determines the eligibility of its principals. Each participant may, but is not required to, check the nonprocurement portion of the "Lists of Parties Excluded from Federal Procurement or Nonprocurement Programs" (Nonprocurement List) which is compiled by the General Services Administration.

i. Nothing contained in the foregoing shall be construed to require establishment of a system of records in order to render in good faith the certification required by this clause. The knowledge and information of participant is not required to exceed that which is normally possessed by a prudent person in the ordinary course of business dealings.

j. Except for transactions authorized under paragraph f of these instructions, if a participant in a covered transaction knowingly enters into a lower tier covered transaction with a person who is suspended, debarred, ineligible, or voluntarily excluded from participation in this transaction, in addition to other remedies available to the Federal Government, the department or agency may terminate this transaction for cause or default.

#### Certification Regarding Debarment, Suspension, Ineligibility and Voluntary Exclusion—Primary Covered Transactions

1. The prospective primary participant certifies to the best of its knowledge and belief, that it and its principals:

a. Are not presently debarred, suspended, proposed for debarment, declared ineligible, or voluntarily excluded from covered transactions by any Federal department or agency;

b. Have not within a 3-year period preceding this proposal been convicted of or had a civil judgment rendered against them for commission of fraud or a criminal offense in connection with obtaining, attempting to obtain, or performing a public (Federal, State or local) transaction or contract under a public transaction; violation of Federal or State antitrust statutes or commission of embezzlement, theft, forgery, bribery, falsification or destruction of records, making false statements, or receiving stolen property;

c. Are not presently indicted for or otherwise criminally or civilly charged by a governmental entity (Federal, State or local) with commission of any of the offenses enumerated in paragraph 1b of this certification; and

d. Have not within a 3-year period preceding this application/proposal had one or more public transactions (Federal, State or local) terminated for cause or default.

Where the prospective primary participant is unable to certify to any of the statements in this certification, such prospective participant shall attach an explanation to this proposal.

2. Instructions for Certification - Lower Tier Covered Transactions: (Applicable to all subcontracts, purchase orders and other lower tier transactions of \$25,000 or more - 49 CFR 29)

a. By signing and submitting this proposal, the prospective lower tier is providing the certification set out below.

b. The certification in this clause is a material representation of fact upon which reliance was placed when this transaction was entered into. If it is later determined that the prospective lower tier participant knowingly rendered an erroneous certification, in addition to other remedies available to the Federal Government, the department or agency with which this transaction originated may pursue available remedies, including suspension and/or debarment.

c. The prospective lower tier participant shall provide immediate written notice to the person to which this proposal is submitted if at any time the prospective lower tier participant learns that its certification was erroneous by reason of changed circumstances.

d. The terms “covered transaction,” “debarred,” “suspended,” “ineligible,” “primary covered transaction,” “participant,” “person,” “principal,” “proposal,” and “voluntarily excluded,” as used in this clause, have the meanings set out in the Definitions and Coverage sections of rules implementing Executive Order 12549. You may contact the person to which this proposal is submitted for assistance in obtaining a copy of those regulations.

e. The prospective lower tier participant agrees by submitting this proposal that, should the proposed covered transaction be entered into, it shall not knowingly enter into any lower tier covered transaction with a person who is debarred, suspended, declared ineligible, or voluntarily excluded from participation in this covered transaction, unless authorized by the department or agency with which this transaction originated.

f. The prospective lower tier participant further agrees by submitting this proposal that it will include this clause titled “Certification Regarding Debarment, Suspension, Ineligibility and Voluntary Exclusion-Lower Tier Covered Transaction,” without modification, in all lower tier covered transactions and in all solicitations for lower tier covered transactions.

g. A participation in a covered transaction may rely upon a certification of a prospective participant in a lower tier covered transaction that is not debarred, suspended, ineligible, or voluntarily excluded from the covered transaction, unless it knows that the certification is erroneous. A participant may decide the method and frequency by which it determines the eligibility of its principals. Each participant may, but is not required to, check the Nonprocurement List.

h. Nothing contained in the foregoing shall be construed to require establishment of a system of records in order to render in good faith the certification required by this clause. The knowledge and information of participant is not required to exceed that which is normally possessed by a prudent person in the ordinary course of business dealings.

i. Except for transactions authorized under paragraph e of these instructions, if a participant in a covered transaction knowingly enters into a lower tier covered transaction with a person who is suspended, debarred, ineligible, or voluntarily excluded from participation in this transaction, in addition to other remedies available to the Federal Government, the department or agency with which this transaction originated may pursue available remedies, including suspension and/or debarment.

### **Certification Regarding Debarment,**

#### **Suspension, Ineligibility and Voluntary Exclusion—Lower Tier Covered Transactions:**

1. The prospective lower tier participant certifies, by submission of this proposal, that neither it nor its principals is presently debarred, suspended, proposed for debarment, declared ineligible, or voluntarily excluded from participation in this transaction by any Federal department or agency.

2. Where the prospective lower tier participant is unable to certify to any of the statements in this certification, such prospective participant shall attach an explanation to this proposal.

**XII. CERTIFICATION REGARDING USE OF CONTRACT FUNDS FOR LOBBYING** (Applicable to all Federal-aid construction contracts and to all related subcontracts which exceed \$100,000 - 49 CFR 20)

1. The prospective participant certifies, by signing and submitting this bid or proposal, to the best of his or her knowledge and belief, that:

a. No Federal appropriated funds have been paid or will be paid, by or on behalf of the undersigned, to any person for influencing or attempting to influence an officer or employee of any Federal agency, a Member of Congress, an officer or employee of Congress, or an employee of a Member of Congress in connection with the awarding of any Federal contract, the making of any Federal grant, the making of any Federal loan, the entering into of any cooperative agreement, and the extension, continuation, renewal, amendment, or modification of any Federal contract, grant, loan, or cooperative agreement.

b. If any funds other than Federal appropriated funds have been paid or will be paid to any person for influencing or attempting to influence an officer or employee of any Federal agency, a Member of Congress, an officer or employee of Congress, or an employee of a Member of Congress in connection with this Federal contract, grant, loan, or cooperative agreement, the undersigned shall complete and submit Standard Form-LLL, "Disclosure Form to Report Lobbying," in accordance with its instructions.

2. This certification is a material representation of fact upon which reliance was placed when this transaction was made or entered into. Submission of this certification is a prerequisite for making or entering into this transaction imposed by 31 U.S.C. 1352. Any person who fails to file the required certification shall be subject to a civil penalty of not less than \$10,000 and not more than \$100,000 for each such failure.

3. The prospective participant also agrees by submitting his or her bid or proposal that he or she shall require that the language of this certification be included in all lower tier subcontracts, which exceed \$100,000 and that all such recipients shall certify and disclose accordingly.

This page is blank intentionally.

**SOLICITATION #17047SCOPE OF WORK**  
**KAKE & KIPNUK RPSU POWER PLANT MODULES**  
**ELECTRICAL & MECHANICAL INSTALLATION LABOR**

**Electrical and Mechanical Services Included**

- 1) Contractor shall provide one foreman with experience installing generation equipment and other commercial and industrial mechanical systems and equipment. The foreman shall be a hands-on working foreman, not just supervisory. The duties shall include but not be limited to: serving as the primary point of contact with AEA; overseeing and supervising the work of all craftsmen on the job; coordinating mechanical and electrical work; moving, placing, and installing large equipment such as generators, mufflers, tanks, etc.; installing miscellaneous mechanical equipment such as fans, pumps, filters, etc.; constructing racks for support of raceways, piping, and equipment; and other tasks as required.
- 2) Contractor shall provide two journeymen electricians with current State of Alaska Certificate of Fitness. At least one of the journeymen provided shall have experience in the installation of industrial diesel power generation, switchgear and control systems. The other journeyman provided shall have experience in the installation of various industrial and commercial electrical systems.
- 3) Contractor shall provide one apprentice electrician with a current State of Alaska apprentice card with a minimum of two years of experience in commercial and industrial systems.
- 4) Contractor shall provide one journeyman pipe welder with current 6G or equivalent pipe welding certificate and with experience in the installation of threaded and welded steel piping, welded steel exhaust tubing, and solder copper piping systems. Note that it is acceptable for the Contractor to provide two journeymen – one for welded piping and one for soldered piping; however, both must bill at the same rate.
- 5) Contractor shall provide one journeyman plumber/pipe fitter with experience in the installation of threaded and welded steel piping, and solder copper piping systems.
- 6) Contractor shall provide one apprentice plumber/pipe fitter with a minimum of two years of experience in the installation of threaded and welded steel piping, and solder copper piping systems.
- 7) Contractor shall provide all small tools required for the work. This refers primarily to hand tools and personal tools. Note that AEA has a very substantial tool and equipment inventory. Major tools will be available for use by the Contractor as listed under the Exclusions below.

**Exclusions:**

- 1) All construction materials will be furnished by AEA at no cost to the Contractor, see Special Conditions.
- 2) Power, heat, and lights as required will be furnished by AEA at no cost to the Contractor.
- 3) A break area and restroom are available for use on site by the Contractor's workers.
- 4) The following tools/equipment will available for use at the Contractor's discretion and at no cost to the Contractor: Ladders and scaffolds, pipe threader with dies ½" through 3", pallet jacks, chain hoists, electric welder, grinders, oxy-acetylene torch

**SOLICITATION #17047SCOPE OF WORK**  
**KAKE & KIPNUK RPSU POWER PLANT MODULES**

**ELECTRICAL & MECHANICAL INSTALLATION LABOR**

set with bottles, T-drill, pipe stands and vises, portable and stationary band saws, chop saw, hydraulic conduit bender with shoes for EMT and rigid through 2”.

- 5) Startup and testing of the powerhouse module will be performed by AEA and is not part of this scope of work. The Contractor may be required to support this effort.
- 6) The Contractor will not be required to apply for local or State permits.

**Special Conditions:**

- 1) Drawings are attached to define the nature of the work involved, not to delineate the project scope. This solicitation is for an Hourly Contract for labor at fixed hourly rates, not a Lump Sum Bid.
- 2) The fabrication work is being performed off the Kipnuk and Kake sites and is not subject to prevailing wage rates. Certified payroll with Alaska DOL is not required.
- 3) All electrical installation work shall be performed under the supervision of an electrical contractor with a current State of Alaska Electrical Administrator license.
- 4) AEA or their representative will provide construction administration of the electrical and mechanical work. There will be coordination meetings conducted at least weekly.
- 5) AEA or their representative will be responsible to ensure quality of work and production rate. If skill, experience, or productivity of the foreman, journeymen or apprentices is determined to be inadequate the Contractor shall assign different staff at the request of AEA. Inability to perform adequately may result in termination of the Contract.
- 6) Access to the AEA property will only be allowed during normal State of Alaska work hours, 7:00 am to 5:00 pm Monday thru Friday, excluding State holidays. Contractor access hours may be extended at the sole discretion of AEA.
- 7) The work schedule is to be 40 hours per week, per man. Overtime is not anticipated at this time. Overtime will only be allowed when authorized in writing by AEA.
- 8) AEA has pre-purchased the majority of required materials but acknowledges that some additional materials may be required. The Contractor will maintain a running list of additional materials and make requests to AEA for additional materials one time per week. AEA will provide a material expediter at no cost to the Contractor to procure the requested materials. Contractor shall plan work activities to remain productive with the materials currently on site or shall stop work until required materials are available.

**Contractor Qualifications:**

- 1) The Contractor and any subcontractors shall be regularly engaged in the business of construction of industrial electrical and mechanical systems. After bid opening and prior to contract award the Owner may request the Contractor to provide documentation to demonstrate at least three years' similar project experience, electrical administrators license, and project references with points of contact and phone numbers.
- 2) The Contractor's foreman and journeymen staff assigned to the project shall have experience and knowledge with similar systems. After bid opening and prior to

**SOLICITATION #17047SCOPE OF WORK**  
**KAKE & KIPNUK RPSU POWER PLANT MODULES**  
**ELECTRICAL & MECHANICAL INSTALLATION LABOR**

contract award the Owner may request the contractor to provide the resumes of the staff assigned to the project demonstrating their certifications and experience.



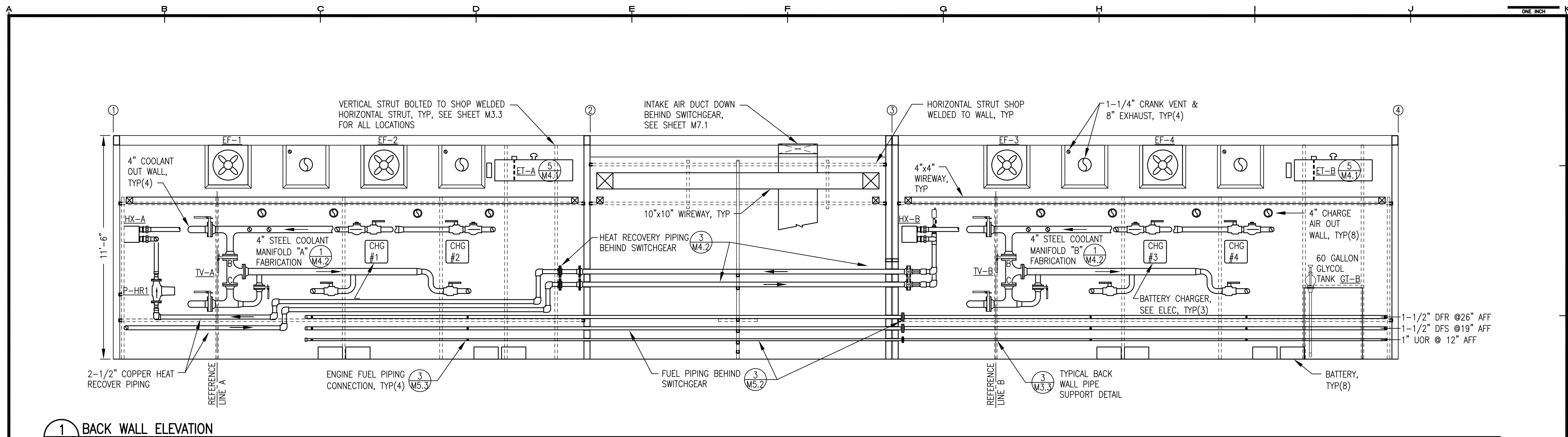

**1** BACK WALL ELEVATION  
**M3.1** 3/8"=1'-0"

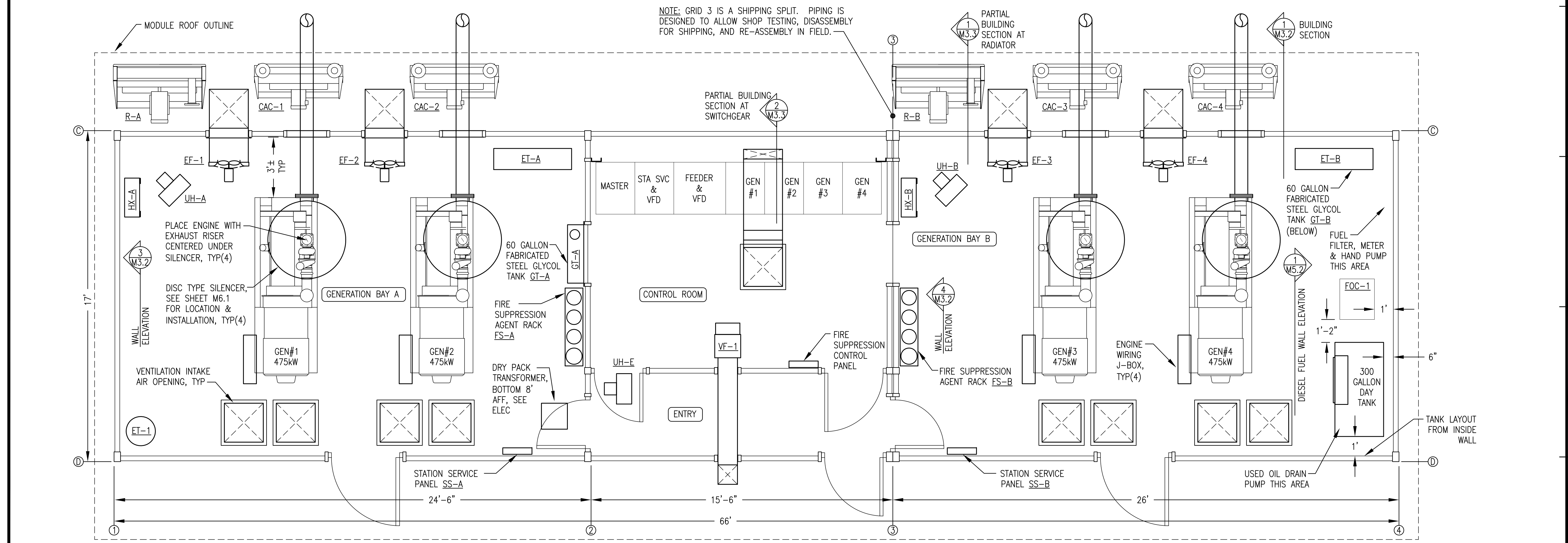

**2** EQUIPMENT LAYOUT PLAN  
**M3.1** 3/8"=1'-0"

REVISIONS	MARK	DATE	DESCRIPTION
1			
2			
3			
4			
5			

**95% SUBMITTAL NOT FOR CONSTRUCTION**

**HDL ENGINEERING Consultants**  
 (907) 564-2120  
 www.hdalaska.com

**Groy Stassel Engineering, Inc.**  
 P.O. 111405  
 ANC, AK 98511  
 (907) 349-0100

**ALASKA ENERGY AUTHORITY**  
 ENERGY AUTHORITY

**ALASKA ENERGY AUTHORITY**  
 KAKE, ALASKA

KAKE RPSU PROJECT

SHEET TITLE  
**EQUIPMENT LAYOUT PLAN & BACK WALL ELEVATION**

SHEET  
**M3.1**

DRAWN BY: WJP CHECKED BY: BCG  
 DATE: 10/20/16 SCALE: AS SHOWN  
 JOB NUMBER:

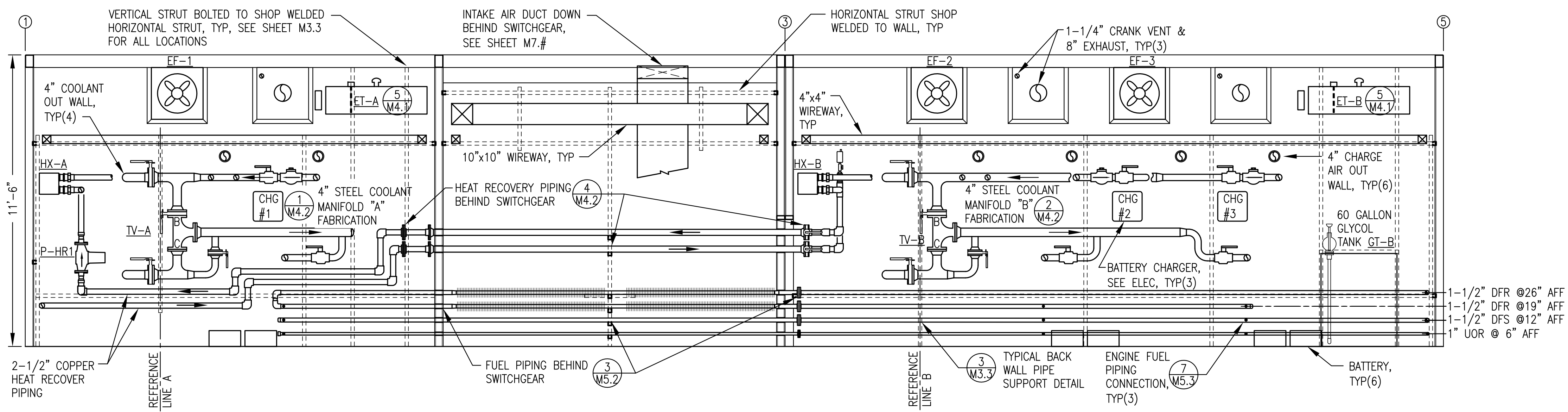

**1** BACK WALL ELEVATION  
**M3.1** 3/8"=1'-0"

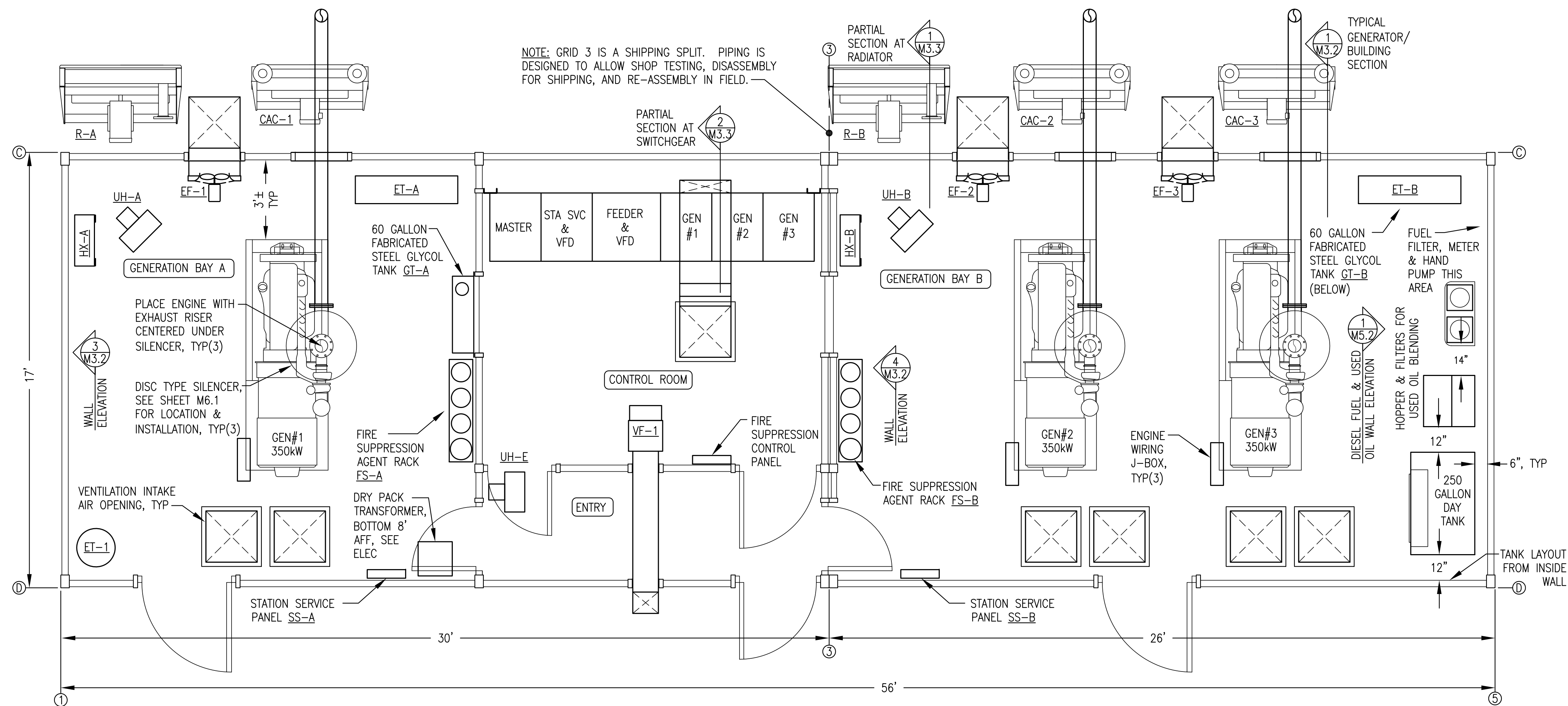

**2** EQUIPMENT LAYOUT PLAN  
**M3.1** 3/8"=1'-0"



**STATE OF ALASKA, AIDEA/AEA  
RURAL POWER SYSTEM UPGRADE**

KIPNUK POWER PLANT  
KIPNUK, ALASKA

**95% DESIGN - NOT FOR CONSTRUCTION**

REVISIONS	DESCRIPTION
REV DATE	

VERIFY SCALES  
0 1"  
THIS BAR REPRESENTS ONE INCH ON ORIGINAL DRAWING

DATE: 10/20/16  
DRAWN BY: JTD  
CHECKED BY: BCG  
JOB NUMBER:

DRAWING TITLE:  
EQUIPMENT LAYOUT PLAN & BACK WALL ELEVATION

**M3.1**

# Option #2

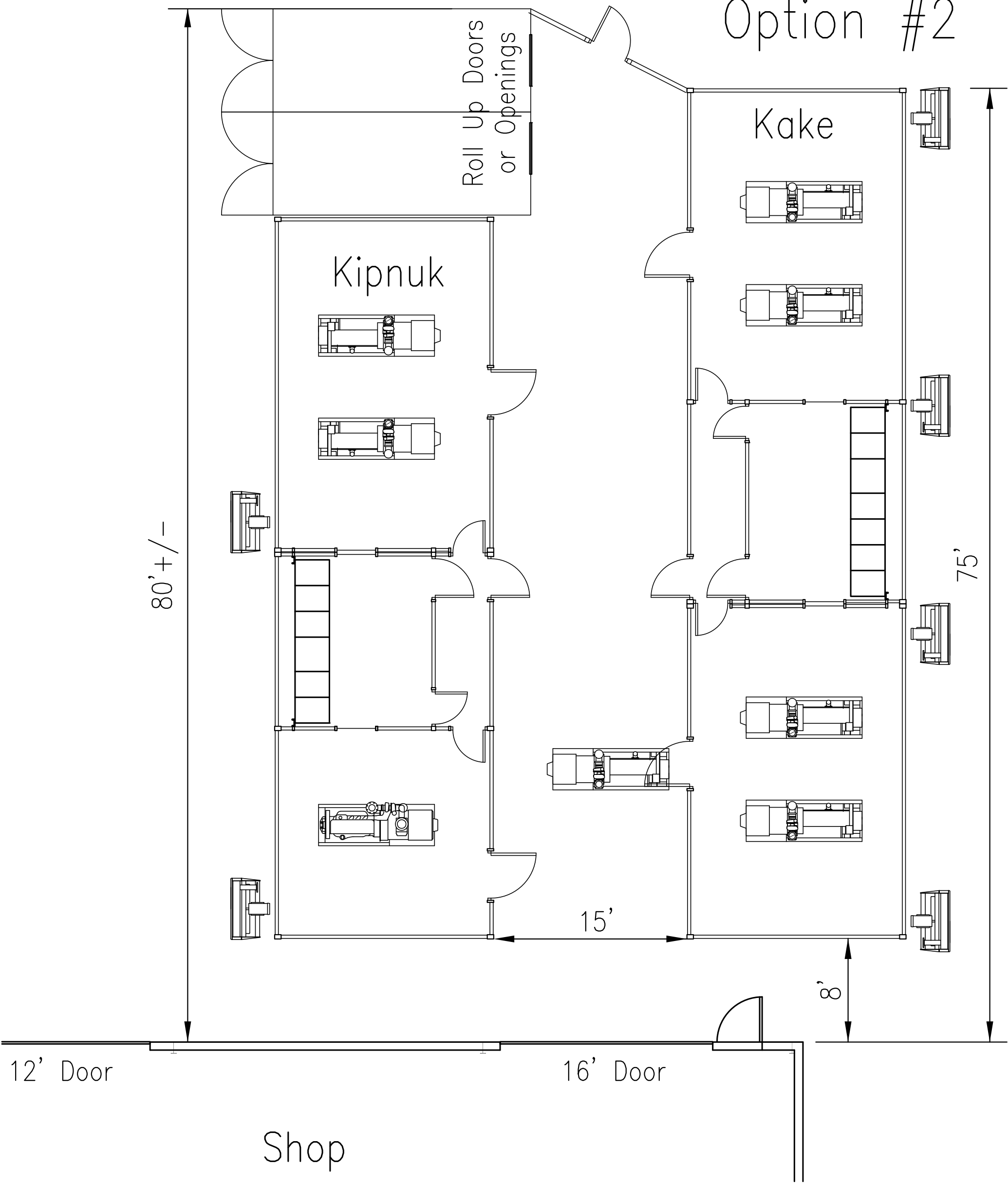

80' +/-

75'

15'

8'

12' Door

16' Door

Shop

Kipnuk

Kake

Roll Up Doors  
or Openings