

ALASKA ENERGY AUTHORITY - INVITATION TO BID (ITB) # 23098

Issue Date: April 13 2023

NELSON LAGOON POWER SYSTEM UPGRADE PROJECT PRIME POWER SWITCHGEAR PURCHASE

Alaska Energy Authority (AEA) is soliciting bids to purchase commodities as indicated in Appendix C - Scope of Work, Appendix D - Bid Schedule, and Appendix E - Specifications.

IMPORTANT NOTICE: If you received this solicitation from the State of Alaska’s “Online Public Notice” web site, or you downloaded this solicitation from AEA’s procurement website, you must register on the online Plan Holders List to receive notification of subsequent amendments to the solicitation. Failure to register may result in the rejection of your bid. It is the bidder’s responsibility to ensure that they have received all addenda affecting this ITB. To register, go to www.aideaaaprocurement.org and select the Plan Holders Registration link and complete the Planholders Registration.

BIDDER'S NOTICE: By signature on this form, the bidder certifies that they comply with the following:

- (1) the bidder has a valid Alaska business license or will obtain one prior to award of any contract resulting from this ITB. If the bidder possesses a valid Alaska business license, the license number must be written below or one the following forms of evidence submitted with the bid:
 - a canceled check for the business license fee;
 - a copy of the business license application with a receipt date stamp from the State's business license office;
 - a receipt from the State’s business license office for the license fee;
 - a copy of the bidder’s valid business license;
 - a sworn notarized affidavit that the bidder has applied and paid for a business license;
- (2) the price(s) submitted was arrived at independently and without collusion, under penalty of perjury, and that the bidder is complying with:
 - the laws of the State of Alaska;
 - the applicable portion of the Federal Civil Rights Act of 1964;
 - the Equal Employment Opportunity Act and the regulations issued thereunder by the state and federal Government;
 - the Americans with Disabilities Act of 1990 and the regulations issued thereunder by the state and federal government;
 - the bid will remain open and valid for at least 30 days;
 - all terms and conditions set out in this Invitation to Bid (ITB).

If a bidder does not hold an Alaska Business License (1) at the time designated in the ITB for opening the Authority will disallow the Alaska Bidder Preference. Bids must also be submitted under the name as appearing on the bidder’s current Alaska business license in order to receive the Alaska Bidder Preference. If a bidder fails to comply with (2) of this paragraph, the Authority may reject the bid, terminate the contract, or consider the contractor in default.

Daniela Patterson AEA Contracting Officer	COMPANY SUBMITTING BID	*DOES YOUR BUSINESS QUALIFY FOR THE ALASKA BIDDER’S PREFERENCE? <input type="checkbox"/> YES <input type="checkbox"/> NO
813 West Northern Lights Blvd Anchorage, AK 99503	AUTHORIZED SIGNATURE	*DOES YOUR BUSINESS QUALIFY FOR THE ALASKA VETERAN PREFERENCE? <input type="checkbox"/> YES <input type="checkbox"/> NO
Phone: (907) 771-3026 FAX: (907) 771-3044	PRINTED NAME	*SEE ITB FOR EXPLANATION OF CRITERIA TO QUALIFY
Email: AEAProcurement@akenergyauthority.org	DATE	TELEPHONE NUMBER
ALASKA BUSINESS LICENSE NUMBER	FEDERAL TAX ID NUMBER	E-MAIL ADDRESS

TABLE OF CONTENTS

SECTION 1. INTRODUCTION & INSTRUCTIONS	4
SEC. 1.01 PURPOSE OF THE ITB	4
SEC. 1.02 DEADLINE FOR RECEIPT OF BIDS	4
SEC. 1.03 PRIOR EXPERIENCE	4
SEC. 1.04 INVITATION TO BID (ITB) REVIEW	4
SEC. 1.05 QUESTIONS PRIOR TO DEADLINE FOR RECEIPT OF BIDS	4
SEC. 1.06 SITE INSPECTION	4
SEC. 1.07 SUBMITTING BIDS	4
SEC. 1.08 BID FORMS	5
SEC. 1.09 PRICES	5
SEC. 1.10 PRE-BID CONFERENCE	5
SEC. 1.11 ASSISTANCE TO BIDDERS WITH A DISABILITY	5
SEC. 1.12 AMENDMENTS TO BIDS	6
SEC. 1.13 AMENDMENTS TO THE ITB	6
SEC. 1.14 ITB SCHEDULE	6
SEC. 1.15 ALTERNATE BIDS	6
SEC. 1.16 SUPPORTING INFORMATION	6
SEC. 1.17 FIRM, UNQUALIFIED, AND UNCONDITIONAL OFFER	6
SECTION 2. CONTRACT INFORMATION	7
SEC. 2.01 CONTRACT TERM	7
SEC. 2.02 CONTRACT ADMINISTRATION	7
SEC. 2.03 CONTRACT FUNDING	7
SEC. 2.04 CONTRACT EXTENSION	7
SEC. 2.05 CONTRACT CHANGES – UNANTICIPATED AMENDMENTS	7
SEC. 2.06 SUBCONTRACTORS	7
SEC. 2.07 JOINT VENTURES	7
SEC. 2.08 CONTRACT PERFORMANCE LOCATION	7
SEC. 2.09 RIGHT TO INSPECT PLACE OF BUSINESS	8
SEC. 2.10 SCOPE OF WORK AND SPECIFICATIONS	8
SEC. 2.11 F.O.B. POINT	8
SEC. 2.12 SHIPPING DAMAGE	8
SEC. 2.13 DELIVERY TIME	8
SEC. 2.14 INSPECTION & MODIFICATION - REIMBURSEMENT FOR UNACCEPTABLE DELIVERABLES	8
SEC. 2.15 CONTINUING OBLIGATION OF CONTRACTOR	8
SEC. 2.16 ESTIMATED QUANTITIES	8
SEC. 2.17 CONTRACT PRICE ADJUSTMENTS	8
SEC. 2.18 INFORMAL DEBRIEFING	9
SEC. 2.19 INDEMNIFICATION	9
SEC. 2.20 INSURANCE	9
SEC. 2.21 MANDATORY REPORTING	9
NOT APPLICABLE	9
SECTION 3. CONTRACT INVOICING AND PAYMENTS	10
SEC. 3.01 BILLING INSTRUCTIONS	10
SEC. 3.02 PAYMENT FOR AUTHORITY PURCHASES	10
SEC. 3.03 THIRD-PARTY FINANCING AGREEMENTS NOT ALLOWED	10
SECTION 4. EVALUATION AND CONTRACTOR SELECTION	10
SEC. 4.01 EVALUATION OF BIDS	10
SEC. 4.02 APPLICATION OF PREFERENCES	10

SEC. 4.03	ALASKA BIDDER PREFERENCE	10
SEC. 4.04	ALASKA VETERAN PREFERENCE	10
SEC. 4.05	USE OF LOCAL FOREST PRODUCTS	10
SEC. 4.06	LOCAL AGRICULTURAL AND FISHERIES PRODUCT PREFERENCE	10
SEC. 4.07	ALASKA PRODUCT PREFERENCE.....	10
SEC. 4.08	EMPLOYMENT PROGRAM PREFERENCE	10
SEC. 4.09	ALASKANS WITH DISABILITIES PREFERENCE	11
SEC. 4.10	PREFERENCE QUALIFICATION LETTER	11
SEC. 4.11	EXTENSION OF PRICES.....	11
SEC. 4.12	METHOD OF AWARD	11
SEC. 4.13	NOTICE OF INTENT TO AWARD.....	11
SECTION 5.	GENERAL PROCESS AND LEGAL INFORMATION.....	11
SEC. 5.01	ALASKA BUSINESS LICENSE AND OTHER REQUIRED LICENSES.....	11
SEC. 5.02	AUTHORITY.....	12
SEC. 5.03	COMPLIANCE (REFER TO APPENDIX A, A.9)	12
SEC. 5.04	SUITABLE MATERIALS, ETC. (REFER TO APPENDIX A, A.2)	12
SEC. 5.05	SPECIFICATIONS.....	12
SEC. 5.06	CONTRACTOR SITE INSPECTION.....	12
SEC. 5.07	ORDER DOCUMENTS.....	12
SEC. 5.08	HUMAN TRAFFICKING	12
SEC. 5.09	RIGHT OF REJECTION	13
SEC. 5.10	AUTHORITY NOT RESPONSIBLE FOR PREPARATION COSTS	13
SEC. 5.11	DISCLOSURE OF BID CONTENTS.....	13
SEC. 5.12	ASSIGNMENTS (REFER TO APPENDIX A, A.5).....	14
SEC. 5.13	FORCE MAJEURE (REFER TO APPENDIX A, A.14)	14
SEC. 5.14	DEFAULT (REFER TO APPENDIX A, A.4)	14
SEC. 5.15	DISPUTES (REFER TO APPENDIX A, A.3)	14
SEC. 5.16	SEVERABILITY (REFER TO APPENDIX A, A.16)	14
SEC. 5.17	CONTRACT CANCELLATION.....	14
SEC. 5.18	GOVERNING LAW; FORUM SELECTION (REFER TO APPENDIX A, A.18)	14
SEC. 5.19	SOLICITATION ADVERTISING	14
SEC. 5.20	QUALIFIED BIDDERS.....	14
SEC. 5.21	FEDERALLY IMPOSED TARIFFS	14
SEC. 5.22	PROTEST	15
SECTION 6.	APPENDICES.....	16
(a)	<i>Appendix A – General Conditions</i>	<i>16</i>
(b)	<i>Appendix B – Federal Assurances.....</i>	<i>16</i>
(c)	<i>Appendix C – Scope of Work.....</i>	<i>16</i>
(d)	<i>Appendix D - Bid Schedule</i>	<i>16</i>
(e)	<i>Appendix E – Specifications</i>	<i>16</i>

SECTION 1. INTRODUCTION & INSTRUCTIONS

SEC. 1.01 PURPOSE OF THE ITB

Alaska Energy Authority (AEA) is soliciting bids to purchase commodities as indicated in Appendix C - Scope of Work, Appendix D - Bid Schedule, and Appendix E - Specifications.

SEC. 1.02 DEADLINE FOR RECEIPT OF BIDS

Bids must be received no later than the time and date indicated in the ITB Schedule, Sec. 1.14, at which time they will be publicly opened. Late bids or amendments will be disqualified and not opened or accepted for evaluation. **Due to COVID-19 the bid opening will be conducted telephonically.** Potential bidder may attend telephonically by calling **1-888-585-9008** and when prompted enter **351 122 943 #**.

SEC. 1.03 PRIOR EXPERIENCE

Minimum prior experience, if applicable, is indicated in the attached Specifications. A bidder's failure to meet these minimum prior experience requirements will cause their bid to be considered non-responsive and rejected.

SEC. 1.04 INVITATION TO BID (ITB) REVIEW

Bidders shall carefully review this ITB for defects and questionable or objectionable material. Comments concerning defects and questionable or objectionable material in the ITB should be made in writing and received by the contracting officer at least ten days before the bid opening date. This will allow time for an amendment to be issued if one is required. It will also help prevent the opening of a defective bid, upon which award cannot be made, and the resultant exposure of bidders' prices.

SEC. 1.05 QUESTIONS PRIOR TO DEADLINE FOR RECEIPT OF BIDS

All questions must be in writing and directed to the contracting officer. The interested party must confirm telephone conversations in writing. Two types of questions generally arise. One may be answered by directing the questioner to a specific section of the ITB. These questions may be answered over the telephone. Other questions may be more complex and may require a written amendment to the ITB. The contracting officer will make that decision.

Contracting Officer Daniela Patterson Phone 907-771-3026 AEAProcurement@akenergyauthority.org

SEC. 1.06 SITE INSPECTION

Not Applicable

SEC. 1.07 SUBMITTING BIDS

Bids must be either Emailed, Hand Delivered or Mailed as follows:

EMAIL: AEAProcurement@akenergyauthority.org

HAND DELIVERED OR MAILED: The sealed bid package must be addressed as follows:

Alaska Energy Authority
Attention: **DANIELA PATTERSON**
Invitation to Bid (ITB) Number: **23098**
ITB Title: **Nelson Lagoon Power System Upgrade Prime Power Switchgear Purchase**
813 W NORTHERN LIGHTS BLVD
ANCHORAGE, AK 99503

It is the bidder's responsibility to contact the issuing agency at **907-771-3026** to confirm that the bid has been received. The Authority is not responsible for unreadable, corrupt, or missing attachments.

SEC. 1.08 BID FORMS

Bidders shall use the front page of this ITB and any other forms identified in this ITB for submitting bids. All bids must be signed by an individual authorized to bind the bidder to the provisions of the ITB.

BIDDER'S CERTIFICATION

By signature on the bid, the bidder certifies that they comply with the following:

- A. the laws of the State of Alaska;
- B. the applicable portion of the Federal Civil Rights Act of 1964;
- C. the Equal Employment Opportunity Act and the regulations issued thereunder by the state and federal government;
- D. the Americans with Disabilities Act of 1990 and the regulations issued thereunder by the state and federal government;
- E. all terms and conditions set out in this ITB;
- F. the price(s) submitted was arrived at independently arrived and without collusion, under penalty of perjury; and
- G. that the bid will remain open and valid for at least 30 days.

If any bidder fails to comply with [a] through [g] of this paragraph, the Authority reserves the right to disregard the bid, terminate the contract, or consider the contractor in default.

CONFLICT OF INTEREST

Each bid shall include a statement indicating whether or not the company or any individuals working on the contract has a possible conflict of interest (e.g., currently employed by the State of Alaska or formerly employed by the State of Alaska within the past two years) and, if so, the nature of that conflict. The contracting officer reserves the right to **consider a bid non-responsive and reject it** or cancel the award if any interest disclosed from any source could either give the appearance of a conflict or cause speculation as to the objectivity of the contract to be performed by the bidder.

SEC. 1.09 PRICES

The bidder shall state prices in the units of issue on this ITB. Prices quoted in bids must be exclusive of federal, state, and local taxes. If the bidder believes that certain taxes are payable by the state, the bidder may list such taxes separately, directly below the bid price for the affected item.

SEC. 1.10 PRE-BID CONFERENCE

Not Applicable

SEC. 1.11 ASSISTANCE TO BIDDERS WITH A DISABILITY

Bidders with a disability may receive accommodation regarding the means of communicating this ITB or participating in the procurement process. For more information, contact the contracting officer no later than ten days prior to the deadline for receipt of bids.

SEC. 1.12 AMENDMENTS TO BIDS

Amendments to or withdrawals of bids will only be allowed if acceptable requests are received prior to the deadline that is set for receipt of bids, in accordance with 3 AAC 109.170. No amendments or withdrawals will be accepted after the deadline unless the delay is due to an error of the procurement agency, in accordance with 3 AAC 109.360.

SEC. 1.13 AMENDMENTS TO THE ITB

If an amendment is issued, it will be provided to all who were notified of the ITB and to Planholders who have registered on the ITB Plan Holders Registration at www.aideaaeprocmnt.org.

SEC. 1.14 ITB SCHEDULE

The ITB schedule set out herein represents the Authority's best estimate of the schedule that will be followed. If an Activity of this schedule is changed, the schedule may be adjusted. All times are Alaska Time.

ACTIVITY	TIME	DATE
Issue Date / ITB Released		4/13/2023
Deadline for Protest (10 days prior to Bid Due)	2:00 PM	5/5/2023
Deadline for Comments/Questions (5 days prior to Bid Due)	2:00 PM	5/11/2023
Deadline for Receipt of Bids / Bid Due Date	2:00 PM	5/16/2023

This ITB does not, by itself, obligate the Authority. The Authority's obligation will commence when the contract is approved by the AEA Executive Director, or the Director's designee. Upon written notice to the contractor, the Authority may set a different starting date for the contract. The Authority will not be responsible for any work done by the contractor, even work done in good faith, if it occurs prior to the contract start date set by the Authority.

SEC. 1.15 ALTERNATE BIDS

Bidders may only submit one bid. In accordance with 3 AAC 109.270 alternate bids (bids that offer something different than what is asked for) will be rejected.

SEC. 1.16 SUPPORTING INFORMATION

Bidders shall submit all required technical, specification, and other supporting information with their bid, so that a detailed analysis and determination can be made by the contracting officer that the product offered meets the ITB specifications and that other requirements of the ITB have been met. However, provided a bid meets the requirements for a definite, firm, unqualified, and unconditional offer, the Authority reserves the right to request supplemental information from the bidder, after the bids have been opened, to ensure that the products or services offered completely meet the ITB requirements. The requirement for such supplemental information will be at the reasonable discretion of the Authority and may include the requirement that a bidder will provide a sample product(s) so that the Authority can make a first-hand examination and determination.

A bidder's failure to provide this supplemental information or the product sample(s), within the time set by the Authority, will cause the Authority to consider the offer non-responsive and reject the bid.

SEC. 1.17 FIRM, UNQUALIFIED, AND UNCONDITIONAL OFFER

Bidders must provide enough information with their bid to constitute a definite, firm, unqualified and unconditional offer. To be responsive a bid must constitute a definite, firm, unqualified and unconditional offer to meet all the material terms of the ITB. Material terms are those that could affect the price, quantity, quality, or delivery. Also included as material terms are those which are clearly identified in the ITB and which, for reasons of policy, must be complied with at risk of bid rejection for non-responsiveness.

SECTION 2. CONTRACT INFORMATION

SEC. 2.01 CONTRACT TERM

The length of the contract will be from the date of award until the time of delivery and acceptance at the F.O.B. point.

SEC. 2.02 CONTRACT ADMINISTRATION

The administration of this contract is the responsibility of the contracting officer or person appointed by AEA.

SEC. 2.03 CONTRACT FUNDING

Refer to Appendix A, A.13. AEA estimates a budget of between **\$200,000.00** and **\$300,000.00** dollars for this contract.

SEC. 2.04 CONTRACT EXTENSION

A month-to-month extension may only be executed by the contracting officer via a written contract amendment. Refer to Appendix A, A.15.

SEC. 2.05 CONTRACT CHANGES – UNANTICIPATED AMENDMENTS

During the course of this contract, the contractor may be required to perform additional work. That work will be within the general scope of the initial contract. When additional work is required, the Authority will provide the contractor a written description of the additional work and request the contractor to submit a firm time schedule for accomplishing the additional work and a firm price for the additional work. Cost and pricing data must be provided to justify the cost of such amendments per 3 AAC 109.540.

The contractor will not commence additional work until the contracting officer has secured required Authority approvals necessary for the amendment and issued a written contract amendment.

SEC. 2.06 SUBCONTRACTORS

Subcontractors will not be allowed.

SEC. 2.07 JOINT VENTURES

Joint ventures will not be allowed.

SEC. 2.08 CONTRACT PERFORMANCE LOCATION

The location(s) the work is to be performed, completed and managed at the vendors place of business.

The Authority will not provide workspace for the contractor. The contractor must provide its own workspace.

By signature on their bid, the bidder certifies that all services provided under this contract by the contractor and all subcontractors shall be performed in the United States.

If the bidder cannot certify that all work will be performed in the United States, the bidder must contact the contracting officer in writing to request a waiver at least 10 days prior to the deadline for receipt of bids.

The request must include a detailed description of the portion of work that will be performed outside the United States, where, by whom, and the reason the waiver is necessary.

Failure to comply with these requirements may cause the Authority to reject the bid as non-responsive, or cancel the contract.

SEC. 2.09 RIGHT TO INSPECT PLACE OF BUSINESS

At reasonable times, the Authority may inspect those areas of the contractor's place of business that are related to the performance of a contract. If the Authority makes such an inspection, the contractor must provide reasonable assistance.

SEC. 2.10 SCOPE OF WORK AND SPECIFICATIONS

Alaska Energy Authority (AEA) is soliciting bids to purchase commodities as indicated in Appendix C - Scope of Work, Appendix D - Bid Schedule, and Appendix E - Specifications.

SEC. 2.11 F.O.B. POINT

The F.O.B. point for all items purchased under this contract is the final destination. Ownership of and title to the ordered items remains with the contractor until the items have been delivered to their final destination and are accepted by the Authority. The F.O.B. point is indicated in Appendix C - Scope of Work.

SEC. 2.12 SHIPPING DAMAGE

The Authority will not accept or pay for damaged goods. The contractor must file all claims against the carrier(s) for damages incurred to items in transit from the point of origin to the ultimate destination. The Authority will provide the contractor with written notice when damaged goods are received. The Authority will deduct the cost of the damaged goods from the invoice prior to payment. The contractor must file all claims against the carrier(s) for reimbursement of the loss.

SEC. 2.13 DELIVERY TIME

The Scope of Work indicates the desired delivery in calendar weeks. In the space provided on the Bid Schedule indicate the earliest firm delivery in calendar weeks. Failure to make an entry in the space provided will be construed as an offer to deliver by the desired delivery. Bids that specify deliveries in excess of the desired delivery may be considered non-responsive and may be rejected.

SEC. 2.14 INSPECTION & MODIFICATION - REIMBURSEMENT FOR UNACCEPTABLE DELIVERABLES

The contractor is responsible for proving all products or the completion of all work set out in the contract. All products or work is subject to inspection, evaluation, and approval by the Authority. The Authority may employ all reasonable means to ensure that the work is progressing and being performed in compliance with the contract. The Authority may instruct the contractor to make corrections or modifications if needed in order to accomplish the contract's intent. The contractor will not unreasonably withhold such changes.

Substantial failure of the contractor to perform the contract may cause the Authority to terminate the contract. In this event, the Authority may require the contractor to reimburse monies paid (based on the identified portion of unacceptable products or work received) and may seek associated damages.

SEC. 2.15 CONTINUING OBLIGATION OF CONTRACTOR

Refer to Appendix A, A.17.

SEC. 2.16 ESTIMATED QUANTITIES

The quantities in this ITB are indicated in Appendix D - Bid Schedule.

SEC. 2.17 CONTRACT PRICE ADJUSTMENTS

Not Applicable.

SEC. 2.18 INFORMAL DEBRIEFING

When the contract is completed, an informal debriefing may be performed at the discretion of the contracting officer. If performed, the scope of the debriefing will be limited to the products provided or work performed by the contractor.

SEC. 2.19 INDEMNIFICATION

The contractor shall indemnify, hold harmless, and defend the contracting agency from and against any claim of, or liability for error, omission or negligent act of the contractor under this agreement. The contractor shall not be required to indemnify the contracting agency for a claim of, or liability for, the independent negligence of the contracting agency. If there is a claim of, or liability for, the joint negligent error or omission of the contractor and the independent negligence of the contracting agency, the indemnification and hold harmless obligation shall be apportioned on a comparative fault basis.

“Contractor” and “contracting agency”, as used within this and the following article, include the employees, agents and other contractors who are directly responsible, respectively, to each. The term “independent negligence” is negligence other than in the contracting agency’s selection, administration, monitoring, or controlling of the contractor and in approving or accepting the contractor’s work.

SEC. 2.20 INSURANCE

Without limiting the contractor's indemnification, it is agreed that the contractor shall purchase at its own expense and maintain in force at all times during the performance of services under this agreement the following policies of insurance. Where specific limits are shown, it is understood that they shall be the minimum acceptable limits. If the contractor's policy contains higher limits, the Authority shall be entitled to coverage to the extent of such higher limits.

Certificates of Insurance must be furnished to the contracting officer prior to contract approval and must provide for a notice of cancellation, non-renewal, or material change of conditions in accordance with policy provisions. Failure to furnish satisfactory evidence of insurance or lapse of the policy is a material breach of this contract and shall be grounds for termination of the contractor's services. All insurance policies shall comply with and be issued by insurers licensed to transact the business of insurance under AS 21.

Proof of insurance is required for the following:

- Workers' Compensation Insurance: The contractor shall provide and maintain, for all employees engaged in work under this contract, coverage as required by AS 23.30.045, and; where applicable, any other statutory obligations including but not limited to Federal U.S.L. & H. and Jones Act requirements. The policy must waive subrogation against the state.
- Commercial General Liability Insurance: covering all business premises and operations used by the contractor in the performance of services under this agreement with minimum coverage limits of \$300,000 combined single limit per occurrence.
- Commercial Automobile Liability Insurance: covering all vehicles used by the contractor in the performance of services under this agreement with minimum coverage limits of \$300,000 combined single limit per occurrence.

SEC. 2.21 MANDATORY REPORTING

Not Applicable.

SECTION 3. CONTRACT INVOICING AND PAYMENTS

SEC. 3.01 BILLING INSTRUCTIONS

Invoices must be billed to the ordering agency's address shown on the individual Purchase Order, Contract Award or Delivery Order. The Authority will make payment after it receives the goods or services and the invoice. Questions concerning payment must be addressed to the Authority.

SEC. 3.02 PAYMENT FOR AUTHORITY PURCHASES

Payment for agreements under \$500,000 for the undisputed purchase of goods or services provided to the Authority will be made within 30 days of the receipt of a proper billing or the delivery of the goods or services to the location(s) specified in the agreement, whichever is later.

SEC. 3.03 THIRD-PARTY FINANCING AGREEMENTS NOT ALLOWED

Because of the additional administrative and accounting time required of the Authority when third party financing agreements are permitted, they will not be allowed under this contract.

SECTION 4. EVALUATION AND CONTRACTOR SELECTION

SEC. 4.01 EVALUATION OF BIDS

After bid opening, the contracting officer will evaluate the bids for responsiveness. Bids deemed non-responsive will be eliminated from further consideration. An evaluation may not be based on discrimination due the race, religion, color, national origin, sex, age, marital status, pregnancy, parenthood, disability, or political affiliation of the bidder.

SEC. 4.02 APPLICATION OF PREFERENCES

Because the federal funding source prohibits the use of local preferences in the selection of contractors no Alaskan Bidder, Alaskan Products, or Alaskan Employment Program preferences will be used in determining the lowest responsive and responsible bidder.

SEC. 4.03 ALASKA BIDDER PREFERENCE

Not Applicable.

SEC. 4.04 ALASKA VETERAN PREFERENCE

Not Applicable.

SEC. 4.05 USE OF LOCAL FOREST PRODUCTS

Not Applicable.

SEC. 4.06 LOCAL AGRICULTURAL AND FISHERIES PRODUCT PREFERENCE

Not Applicable.

SEC. 4.07 ALASKA PRODUCT PREFERENCE

Not Applicable.

SEC. 4.08 EMPLOYMENT PROGRAM PREFERENCE

Not Applicable.

SEC. 4.09 ALASKANS WITH DISABILITIES PREFERENCE

Not Applicable.

SEC. 4.10 PREFERENCE QUALIFICATION LETTER

Not Applicable.

SEC. 4.11 EXTENSION OF PRICES

In case of error in the extension of prices in the bid, the unit prices will govern; in a lot bid, the lot prices will govern.

SEC. 4.12 METHOD OF AWARD

Award will be made to the lowest responsive and responsible bidder. In order to be considered responsive, bidders must bid on all items.

SEC. 4.13 NOTICE OF INTENT TO AWARD

After the responses to this ITB have been opened and evaluated, a tabulation of the bids will be prepared. This tabulation, called a Notice of Intent to Award, serves two purposes. It lists the name of each company or person that offered a bid and the price they bid. It also provides notice of the Authority's intent to award a contract(s) to the bidder(s) indicated. A copy of the Notice of Intent will be emailed to each company or person who responded to the ITB. Bidders identified as the apparent low responsive bidders are instructed not to proceed until a Purchase Order, Contract Award, Lease, or some other form of written notice is given by the contracting officer. A company or person who proceeds prior to receiving a Purchase Order, Contract Award, Lease, or some other form of written notice from the contracting officer does so without a contract and at their own risk.

SECTION 5. GENERAL PROCESS AND LEGAL INFORMATION

SEC. 5.01 ALASKA BUSINESS LICENSE AND OTHER REQUIRED LICENSES

Prior to the award of a contract, a bidder must hold a valid Alaska business license. However, in order to receive the Alaska Bidder Preference and other related preferences, such as the Alaska Veteran Preference and Alaskans with Disabilities Preference, a bidder must hold a valid Alaska business license prior to the deadline for receipt of bids. Bidders should contact the **Department of Commerce, Community and Economic Development, Division of Corporations, Business, and Professional Licensing, PO Box 110806, Juneau, Alaska 99811-0806**, for information on these licenses. Acceptable evidence that the bidder possesses a valid Alaska business license may consist of any one of the following:

- copy of an Alaska business license;
- certification on the bid that the bidder has a valid Alaska business license and has included the license number in the bid;
- a canceled check for the Alaska business license fee;
- a copy of the Alaska business license application with a receipt stamp from the state's occupational licensing office; or
- a sworn and notarized statement that the bidder has applied and paid for the Alaska business license.

You are not required to hold a valid Alaska business license at the time bids are opened if you possess one of the following licenses and are offering services or supplies under that specific line of business:

- fisheries business licenses issued by Alaska Department of Revenue or Alaska Department of Fish and Game,
- liquor licenses issued by Alaska Department of Revenue for alcohol sales only,
- insurance licenses issued by Alaska Department of Commerce, Community and Economic Development, Division of Insurance, or
- Mining licenses issued by Alaska Department of Revenue.

Prior the deadline for receipt of bids, all bidders must hold any other necessary applicable professional licenses required by Alaska Statute.

SEC. 5.02 AUTHORITY

This ITB is written in accordance with 3 AAC 109 and 2 AAC 12.

SEC. 5.03 COMPLIANCE (Refer to Appendix A, A.9)

SEC. 5.04 SUITABLE MATERIALS, ETC. (Refer to Appendix A, A.2)

SEC. 5.05 SPECIFICATIONS

Unless otherwise specified in this ITB, product brand names or model numbers specified in this ITB are examples of the type and quality of product required, and are not statements of preference. If the specifications describing an item conflict with a brand name or model number describing the item, the specifications govern. Reference to brand name or number does not preclude an offer of a comparable or better product, if full specifications and descriptive literature are provided for the product. Failure to provide such specifications and descriptive literature may be cause for rejection of the offer.

SEC. 5.06 CONTRACTOR SITE INSPECTION

The Authority may conduct on-site visits to evaluate the bidder's capacity to perform the contract. A bidder must agree, at risk of being found non-responsive and having its bid rejected, to provide the Authority reasonable access to relevant portions of its work sites. Individuals designated by the contracting officer at the Authority's expense will make site inspection.

SEC. 5.07 ORDER DOCUMENTS

Except as specifically allowed under this ITB, an ordering agency will not sign any vendor contract. The Authority is not bound by a vendor contract signed by a person who is not specifically authorized to sign for the Authority under this ITB. Unless otherwise specified in this ITB, the Authority Purchase Order, Contract Award and Delivery Order are the only order documents that may be used to place orders against the contract(s) resulting from this ITB.

SEC. 5.08 HUMAN TRAFFICKING

By signature on their bid, the bidder certifies that the bidder is not established and headquartered or incorporated and headquartered in a country recognized as Tier 3 in the most recent United States Department of State's Trafficking in Persons Report.

The most recent United States Department of State's Trafficking in Persons Report can be found at the following website: <http://www.state.gov/j/tip/>

Failure to comply with this requirement will cause the Authority to reject the bid as non-responsive, or cancel the contract.

SEC. 5.09 RIGHT OF REJECTION

Bidders must comply with all of the terms of this ITB, 3 AAC 109 (Procurement for Alaska Energy Authority Managed Grants), and all applicable local, state, and federal laws, codes, and regulations. The contracting officer may reject any bid that does not comply with all of the material and substantial terms, conditions, and performance requirements of the ITB.

Bidders may not qualify the bid nor restrict the rights of the Authority. If a bidder does so, the contracting officer may determine the bid to be a non-responsive counter-offer and the bid may be rejected.

Minor informalities that:

- do not affect responsiveness;
- are merely a matter of form or format;
- do not change the relative standing or otherwise prejudice other offers;
- do not change the meaning or scope of the RFP;
- are trivial, negligible, or immaterial in nature;
- do not reflect a material change in the work; or
- do not constitute a substantial reservation against a requirement or provision;

may be waived by the contracting officer.

The Authority reserves the right to refrain from making an award if it determines that to be in its best interest.

A bid from a debarred or suspended bidder shall be rejected.

SEC. 5.10 AUTHORITY NOT RESPONSIBLE FOR PREPARATION COSTS

The Authority will not pay any cost associated with the preparation, submittal, presentation, or evaluation of any bid.

SEC. 5.11 DISCLOSURE OF BID CONTENTS

All bid prices become public information at the bid opening. After the deadline for receipt of bids, all other bid material submitted become the property of the State of Alaska and may be returned only at the Authority's option. AAC 109.270 and 3 AAC 109.700 require public records to be open to reasonable inspection. All other bid information will be held in confidence during the evaluation process and prior to the time a Notice of Intent to Award is issued. Thereafter, bids will become public information.

Trade secrets and other proprietary data contained in bids may be held confidential if the bidder requests, in writing, that the contracting officer does so, and if the contracting officer agrees, in writing, to do so. The bidder's request must be included with the bid, must clearly identify the information they wish to be held confidential, and include a statement that sets out the reasons for confidentiality. Unless the contracting officer agrees in writing to hold the requested information confidential, that information will also become public after the Notice of Intent to Award is issued.

SEC. 5.12 ASSIGNMENTS (Refer to Appendix A, A.5)

Bids that are conditioned upon the Authority's approval of an assignment will be rejected as non-responsive.

SEC. 5.13 FORCE MAJEURE (Refer to Appendix A, A.14)

SEC. 5.14 DEFAULT (Refer to Appendix A, A.4)

SEC. 5.15 DISPUTES (Refer to Appendix A, A.3)

SEC. 5.16 SEVERABILITY (Refer to Appendix A, A.16)

SEC. 5.17 CONTRACT CANCELLATION

The Authority reserves the right to cancel the contract at its convenience upon **30** calendar days written notice to the contractor. The Authority is only liable for payment in accordance with the payment provisions of this contract for supplies or services provided before the effective date of termination.

SEC. 5.18 GOVERNING LAW; FORUM SELECTION (Refer to Appendix A, A.18)

SEC. 5.19 SOLICITATION ADVERTISING

Public notice has been provided in accordance with 3 AAC 109.150.

SEC. 5.20 QUALIFIED BIDDERS

Per 2 AAC 12.875, unless provided for otherwise in the ITB, to qualify as a bidder for award of a contract issued under 3 AAC 109, the bidder must:

- 1) Add value in the contract by actually performing, controlling, managing, or supervising the services to be provided; or
- 2) Be in the business of selling and have actually sold on a regular basis the supplies that are the subject of the ITB.

If the bidder leases services or supplies or acts as a broker or agency in providing the services or supplies in order to meet these requirements, the contracting officer may not accept the bidder as a qualified bidder under 3 AAC 109.

SEC. 5.21 FEDERALLY IMPOSED TARIFFS

Changes in price (increase or decrease) resulting directly from a new or updated federal tariff, excise tax, or duty, imposed after contract award may be adjusted during the contract period or before delivery into the United States via contract amendment.

- **Notification of Changes:** The contractor must promptly notify the contracting officer in writing of any new, increased, or decreased federal excise tax or duty that may result in either an increase or decrease in the contact price and shall take appropriate action as directed by the contracting officer.
- **After-imposed or Increased Taxes and Duties:** Any federal excise tax or duty for goods or services covered by this contract that was exempted or excluded on the contract award date but later imposed on the contractor during the contract period, as the result of legislative, judicial, or administrative action may result in a price increase provided:

- a) The tax or duty takes effect after the contract award date and isn't otherwise addressed by the contract;
 - b) The contractor warrants, in writing, that no amount of the newly imposed federal excise tax or duty or rate increase was included in the contract price, as a contingency or otherwise.
- **After-relieved or Decreased Taxes and Duties:** The contract price shall be decreased by the amount of any decrease in federal excise tax or duty for goods or services under the contract, except social security or other employment taxes, that the contractor is required to pay or bear, or does not obtain a refund of, through the contractor's fault, negligence, or failure to follow instructions of the contracting officer.
 - **Authority's Ability to Make Changes:** The Authority reserves the right to request verification of federal excise tax or duty amounts on goods or services covered by this contract and increase or decrease the contract price accordingly.
 - **Price Change Threshold:** No adjustment shall be made in the contract price under this clause unless the amount of the adjustment exceeds \$250.

SEC. 5.22 PROTEST

3 AAC 109.570 provides that an interested party may protest the content of the ITB.

An interested party is defined in 3 AAC 109.900 (17) as "an actual or prospective bidder or offeror whose economic interest might be affected substantially and directly by the issuance of a contract solicitation, the award of a contract, or the failure to award a contract."

If an interested party wishes to protest the content of a solicitation, the protest must be received, in writing, by the contracting officer at least ten days prior to the deadline for receipt of bids.

3 AAC 109 also provides that an interested party may protest the award of a contract or the proposed award of a contract.

If a bidder wishes to protest the award of a contract or the proposed award of a contract, the protest must be received, in writing, by the contracting officer within 10 days after the date the Notice of Intent to Award for the contract is issued.

A protester must have submitted a bid in order to have sufficient standing to protest the proposed award of a contract. Protests must include the following information:

- the name, address, and telephone number of the protester;
- the signature of the protester or the protester's representative;
- identification of the contracting agency and the solicitation or contract at issue;
- a detailed statement of the legal and factual grounds of the protest including copies of relevant documents; and the form of relief requested.

Protests filed by telex or telegram are not acceptable because they do not contain a signature. Fax copies containing a signature are acceptable.

The contracting officer will issue a written response to the protest. The response will set out the contracting officer's decision and contain the basis of the decision within the statutory time limit in 3 AAC 109.570. A copy of the decision will be furnished to the protester by certified mail, fax or another method that provides evidence of receipt.

All bidders will be notified of any protest. The review of protests, decisions of the contracting officer, appeals, and hearings, will be conducted in accordance with 3 AAC 109 – Procurement for Alaska Energy Authority Managed Grants.)

SECTION 6. APPENDICES

- (a) Appendix A – General Conditions
- (b) Appendix B – Federal Assurances
- (c) Appendix C – Scope of Work
- (d) Appendix D - Bid Schedule
- (e) Appendix E – Specifications

APPENDIX A - GENERAL CONDITIONS

A.1 INSPECTIONS AND REPORTS

The department may inspect, in the manner and at reasonable times it considers appropriate, all of the contractor's facilities and activities under this contract. The contractor shall make progress and other reports in the manner and at the times the department reasonably requires.

A.2 SUITABLE MATERIALS, ETC.

Unless otherwise specified, all materials, supplies or equipment offered by the contractor shall be new, unused, and of the latest edition, version, model or crop and of recent manufacture.

A.3 DISPUTES

If the contractor has a claim arising in connection with the contract that it cannot resolve with the Authority by mutual agreement, it shall pursue the claim, if at all, in accordance with the provisions of 2 AAC 108.915.

A.4 DEFAULT

In case of default by the contractor, for any reason whatsoever, the Authority may procure the goods or services from another source and hold the contractor responsible for any resulting excess cost and may seek other remedies under law or equity.

A.5 NO ASSIGNMENT OR DELEGATION

The contractor may not assign or delegate this contract, or any part of it, or any right to any of the money to be paid under it, except with the written consent of the Contracting Officer.

A.6 NO ADDITIONAL WORK OR MATERIAL

No claim for additional supplies or services, not specifically provided in this contract, performed or furnished by the contractor, will be allowed, nor may the contractor do any work or furnish any material not covered by the contract unless the work or material is ordered in writing by the Contracting Officer.

A.7 INDEPENDENT CONTRACTOR

The contractor and any agents and employees of the contractor act in an independent capacity and are not officers or employees or agents of the Authority in the performance of this contract.

A.8 PAYMENT OF TAXES

As a condition of performance of this contract, the contractor shall pay all federal, State, and local taxes incurred by the contractor and shall require their payment by any subcontractor or any other persons in the performance of this contract. Satisfactory performance of this paragraph is a condition precedent to payment by the Authority under this contract.

A.9 COMPLIANCE

In the performance of this contract, the contractor must comply with all applicable federal, state, and borough regulations, codes, and laws, and be liable for all required insurance, licenses, permits and bonds.

A.10 CONFLICTING PROVISIONS

Unless specifically amended and approved by the Department of Law, the terms of this contract supersede any provisions the contractor may seek to add. The contractor may not add additional or different terms to this contract; AS 45.02.207(b)(1). The contractor specifically acknowledges and agrees that, among other things, provisions in any documents it sees to append hereto that purport to (1) waive the State of Alaska's sovereign immunity, (2) impose indemnification obligations on the Authority, or (3) seek to limit liability of the contractor for acts of contractor negligence, are expressly superseded by this contract and are void.

A.11 OFFICIALS NOT TO BENEFIT

Contractor must comply with all applicable federal or State laws regulating ethical conduct of public officers and employees.

A.12 CONTRACT PRICES

Contract prices for commodities must be in U.S. funds and include applicable federal duty, brokerage fees, packaging, and transportation cost to the FOB point so that upon transfer of title the commodity can be utilized without further cost. Prices for services must be in U.S. funds and include applicable federal duty, brokerage fee, packaging, and transportation cost so that the services can be provided without further cost.

A.13 CONTRACT FUNDING

Contractors are advised that funds are available for the initial purchase and/or the first term of the contract. Payment and performance obligations for succeeding purchases and/or additional terms of the contract are subject to the availability and appropriation of funds.

A.14 FORCE MAJEURE

The parties to this contract are not liable for the consequences of any failure to perform, or default in performing, any of their obligations under this Agreement, if that failure or default is caused by any unforeseeable Force Majeure, beyond the control of, and without the fault or negligence of, the respective party. For the purposes of this Agreement, Force Majeure will mean war (whether declared or not); revolution; invasion; insurrection; riot; civil commotion; sabotage; military or usurped power; lightning; explosion; fire; storm; drought; flood; earthquake; epidemic; quarantine; strikes; acts or restraints of governmental authorities affecting the project or directly or indirectly prohibiting or restricting the furnishing or use of materials or labor required; inability to secure materials, machinery, equipment or labor because of priority, allocation or other regulations of any governmental authorities.

A.15 CONTRACT EXTENSION

Unless otherwise provided, the Authority and the contractor agree: (1) that any holding over of the contract excluding any exercised renewal options, will be considered as a month-to-month extension, and all other terms and conditions shall remain in full force and effect, and (2) to provide written notice to the other party of the intent to cancel such month-to-month extension at least thirty (30) days before the desired date of cancellation.

A.16 SEVERABILITY

If any provision of the contract is declared by a court to be illegal or in conflict with any law, the validity of the remaining terms and provisions will not be affected; and, the rights and obligations of the parties will be construed and enforced as if the contract did not contain the particular provision held to be invalid.

A.17 CONTINUING OBLIGATION OF CONTRACTOR

Notwithstanding the expiration date of this contract, the contractor is obligated to fulfill its responsibilities until warranty, guarantee, maintenance and parts availability requirements have completely expired.

A.18 GOVERNING LAW; FORUM SELECTION

This contract is governed by the laws of the State of Alaska. To the extent not otherwise governed by Article 3 of this Appendix, any claim concerning this contract shall be brought only in the Superior Court of the State of Alaska and not elsewhere.

APPENDIX B – FEDERAL ASSURANCES

Because this contract is funded with federal funds, the following contract provisions shall apply, where applicable, to all work performed on the contract by the contractor's own organization and by subcontractors. As provided in this Section, the contractor shall insert in each subcontract all of the stipulations contained in these Required Contract Provisions and further require their inclusion in any lower tier subcontracts or purchase orders that may in turn be made. The prime contractor shall be responsible for compliance by any subcontractor or lower tier subcontractor with all applicable Required Contract Provisions.

B.1 BREACHES AND DISPUTE RESOLUTION.

Contracts in excess of \$250,000. Any dispute arising under this Contract which is not disposed of by mutual agreement shall be resolved in accordance with 2 AAC 108.915.

B.2 TERMINATION.

Contracts in excess of \$10,000. This Contract may be terminated by either party upon 10 days written notice if the other party fails substantially to perform in accordance with its terms through no fault of the party initiating the termination ("Default Termination"). If the Authority terminates this agreement, the Authority will pay the Contractor a sum equal to the percentage of Work completed that can be substantiated either by the Contractor to the satisfaction of the Authority, or by the Authority. If the Authority becomes aware of any non-conformance with the Work or this agreement by the Contractor, the Authority will promptly notify the Contractor in writing of the non-conformance. Should the Contractor's Work remain in non-conformance after having received written notification, the percentage of total compensation attributable to the non-conforming Work may be withheld. The Authority may at any time suspend or terminate ("Convenience Termination") this Agreement for its needs or convenience with or without cause upon written notice. In the event of a Convenience Termination, the Contractor will be compensated for all authorized Work and authorized expenditures performed to the date of receipt of written notice of termination plus reasonable expenses. No fee or other compensation will be due for any incomplete portion of the Work.

B.3 EQUAL EMPLOYMENT OPPORTUNITY.

Except as otherwise provided under [41 CFR Part 60](#), all construction contracts must include, and all contractors and subcontractors must comply with, the equal opportunity clause provided under [41 CFR 60-1.4\(b\)](#), in accordance with Executive Order 11246, "Equal Employment Opportunity" ([30 FR 12319](#), [12935](#), [3 CFR Part, 1964-1965](#) Comp., p. 339), as amended by Executive Order 11375, "Amending Executive Order 11246 Relating to Equal Employment Opportunity," and implementing regulations at [41 CFR part 60](#), "Office of Federal Contract Compliance Programs, Equal Employment Opportunity, Department of Labor."

B.4 DAVIS-BACON ACT, AS AMENDED ([40 U.S.C. 3141-3148](#)).

Construction contracts in excess of \$2,000 are required to comply with the Davis-Bacon Act ([40 U.S.C. 3141-3144](#), and [3146-3148](#)) as supplemented by Department of Labor regulations ([29 CFR Part 5](#), "Labor Standards Provisions Applicable to Contracts Covering Federally Financed and Assisted Construction"). Contractors are required to pay wages to laborers and mechanics at a rate not less than the prevailing wages specified in a wage determination made by the Secretary of Labor. In addition, contractors must pay wages not less than once a week. **A copy of the current prevailing wage determination issued by the Department of Labor is included in this solicitation.** Contract and subcontract awards must be conditioned upon the acceptance of the wage determination. All suspected or reported violations must be reported to the Federal awarding agency.

B.5 COPELAND “ANTI-KICKBACK” ACT ([40 U.S.C. 3145](#))

Construction contracts in excess of \$2,000 are required to comply with the **Copeland “Anti-Kickback” Act ([40 U.S.C. 3145](#))**, as supplemented by Department of Labor regulations ([29 CFR Part 3](#), “Contractors and Subcontractors on Public Building or Public Work Financed in Whole or in Part by Loans or Grants from the United States”). Each contractor or subrecipient is prohibited from inducing, by any means, any person employed in the construction, completion, or repair of public work, to give up any part of the compensation to which he or she is otherwise entitled. All suspected or reported violations must be reported to the Federal awarding agency.

B.6 CONTRACT WORK HOURS/SAFETY STANDARDS ACT ([40 U.S.C. 3701-3708](#)).

Construction contracts in excess of \$100,000 that involve the employment of mechanics or laborers are required to comply with [40 U.S.C. 3702](#) and [3704](#), as supplemented by Department of Labor regulations ([29 CFR Part 5](#)). Under [40 U.S.C. 3702](#) of the Act, each contractor is required to compute the wages of every mechanic and laborer on the basis of a standard work week of 40 hours. Work in excess of the standard work week is permissible provided that the worker is compensated at a rate of not less than one and a half times the basic rate of pay for all hours worked in excess of 40 hours in the work week. The requirements of [40 U.S.C. 3704](#) are applicable to construction work and provide that no laborer or mechanic must be required to work in surroundings or under working conditions which are unsanitary, hazardous or dangerous. These requirements do not apply to the purchases of supplies or materials or articles ordinarily available on the open market, or contracts for transportation or transmission of intelligence.

B.7 RIGHTS TO INVENTIONS MADE UNDER A CONTRACT OR AGREEMENT.

If the recipient or subrecipient wishes to enter into a contract with a small business firm or nonprofit organization regarding the substitution of parties, assignment or performance of experimental, developmental, or research work under that “funding agreement,” the recipient or subrecipient must comply with the requirements of [37 CFR Part 401](#), “Rights to Inventions Made by Nonprofit Organizations and Small Business Firms Under Government Grants, Contracts and Cooperative Agreements,” and any implementing regulations issued by the awarding agency.

B.8 CLEAN AIR ACT ([42 U.S.C. 7401-7671Q](#).) AND THE FEDERAL WATER POLLUTION CONTROL ACT ([33 U.S.C. 1251-1387](#)), AS AMENDED

Contracts in excess of \$150,000 are required to comply with all applicable standards, orders or regulations issued pursuant to the Clean Air Act ([42 U.S.C. 7401-7671q](#)) and the Federal Water Pollution Control Act as amended ([33 U.S.C. 1251-1387](#)). Violations must be reported to the Federal awarding agency and the Regional Office of the Environmental Protection Agency (EPA).

B.9 DEBARMENT AND SUSPENSION (EXECUTIVE ORDERS 12549 & 12689)

A contract award **greater than or equal to \$25,000** (see [2 CFR 180.220](#)) must not be made to parties listed on the government wide exclusions in the System for Award Management (SAM), in accordance with the OMB guidelines at [2 CFR 180](#) that implement Executive Orders 12549 (3 CFR part 1986 Comp., p. 189) and 12689 (3 CFR part 1989 Comp., p. 235), “Debarment and Suspension.” **Contractors that apply or bid for an award exceeding \$25,000 must sign and submit the attached “Debarment” certification with their bid.**

B.10 BYRD ANTI-LOBBYING AMENDMENT ([31 U.S.C. 1352](#))

Each contractor and subcontractor must certify that it will not and has not used Federal appropriated funds to pay any person or organization for influencing or attempting to influence an officer or

employee of any agency, a member of Congress, officer or employee of Congress, or an employee of a member of Congress in connection with obtaining any Federal contract, grant or any other award covered by [31 U.S.C. 1352](#). Each tier must also disclose any lobbying with non-Federal funds that takes place in connection with obtaining any Federal award. Disclosures shall be forwarded from tier to tier up to the Authority. **Contractors that apply or bid for an award exceeding \$100,000 must sign and submit the attached “Lobbying” certification with their bid.**

B.11 PROCUREMENT OF RECOVERED MATERIALS.

A state agency or agency of a political subdivision of a state and its contractors must comply with section 6002 of the Solid Waste Disposal Act, as amended by the Resource Conservation and Recovery Act. The requirements of Section 6002 include procuring only items designated in guidelines of the Environmental Protection Agency (EPA) at [40 CFR part 247](#) that contain the highest percentage of recovered materials practicable, consistent with maintaining a satisfactory level of competition, **where the purchase price of the item exceeds \$10,000 or the value of the quantity acquired during the preceding fiscal year exceeded \$10,000**; procuring solid waste management services in a manner that maximizes energy and resource recovery; and establishing an affirmative procurement program for procurement of recovered materials identified in the EPA guidelines.

B.12 PROHIBITION ON CERTAIN TELECOMMUNICATIONS AND VIDEO SURVEILLANCE SERVICES OR EQUIPMENT.

Contractors and subcontractors are prohibited from entering into a contract (or extending or renewing a contract) to procure or obtain equipment, services, or systems that uses covered telecommunications equipment or services as a substantial or essential component of any system, or as critical technology as part of any system. As described in [Public Law 115-232](#), section 889, covered telecommunications equipment is telecommunications equipment produced by Huawei Technologies Company or ZTE Corporation (or any subsidiary or affiliate of such entities). See [§ 200.216](#).

B.13 DOMESTIC PREFERENCES FOR PROCUREMENTS.

As appropriate and to the extent consistent with law, and to the greatest extent practicable, Contractor’s are required to provide a preference for the purchase, acquisition, or use of goods, products, or materials produced in the United States (including but not limited to iron, aluminum, steel, cement, and other manufactured products). The requirements of this section must be included in all contracts and purchase orders for work or products under this award. See [§ 200.322](#).

The funding for this project is exempt from the Buy American Act and therefore this purchase is not subject to the Buy American Act.

DEBARMENT, SUSPENSION, INELIGIBILITY & VOLUNTARY EXCLUSION – 2 CFR 200.214; Executive Orders 12549 and 12689 [Applicable to all federally assisted contracts which exceed \$25,000]**Instructions for Certification:**

1. The certification in this clause is a material representation of fact upon which reliance was placed when this transaction was entered into. If it is later determined that the prospective contractor and lower tier participants knowingly rendered an erroneous certification, in addition to other remedies available to the Federal Government, the Authority may pursue available remedies, including suspension and/or debarment.
2. The prospective contractor and lower tier participants shall provide immediate written notice to the Authority if at any time the prospective contractor and lower tier participants learns that its certification was erroneous when submitted or has become erroneous by reason of changed circumstances.
3. The terms "covered transaction," "debarred," "suspended," "ineligible," "lower tier covered transaction," "participant," "persons," "lower tier covered transaction," "principal," "proposal," and voluntarily excluded," as used in this clause, have the meanings set out in the Definitions and Coverage sections of rules implementing Executive Orders [12549](#) and 12689. You may contact the Authority for assistance in obtaining a copy of those regulations.
4. The prospective contractor and lower tier participants agrees by submitting this bid or proposal that, should the proposed covered transaction be entered into, it shall not knowingly enter into any lower tier covered transaction with a person who is debarred, suspended, declared ineligible, or voluntarily excluded from participation in this covered transaction, unless authorized in writing by the Authority.
5. The prospective contractor and lower tier participants further agrees by submitting this bid or proposal that it will require the language of this certification be included in all subcontracts and all lower tier participants shall certify compliance with this requirement.
6. A participant in a covered transaction may rely upon a certification of a prospective participant in a lower tier covered transaction that it is not debarred, suspended, ineligible, or voluntarily excluded from the covered transaction, unless it knows that the certification is erroneous. A participant may decide the method and frequency by which it determines the eligibility of its principals. Each participant may, but is not required to, check the Non-procurement List issued by U.S. General Service Administration.
7. Nothing contained in the foregoing shall be construed to require establishment of system of records in order to render in good faith the certification required by this clause. The knowledge and information of a participant is not required to exceed that which is normally possessed by a prudent person in the ordinary course of business dealings.
8. Except for transactions authorized under Paragraph 5 of these instructions, if a participant in a covered transaction knowingly enters into a lower tier covered transaction with a person who is suspended, debarred, ineligible, or voluntarily excluded from participation in this transaction, in addition to all remedies available to the Federal Government, the Authority may pursue available remedies including suspension and/or debarment.

Certification Regarding Debarment, Suspension, Ineligibility and Voluntary Exclusion Lower Tier Covered Transaction

- (1) The prospective contractor and lower tier participants certifies, by submission of this bid or proposal, that neither it nor its "principals" is presently debarred, suspended, proposed for debarment, declared ineligible, or voluntarily excluded from participation in this transaction by any Federal department or agency.
- (2) When the prospective contractor and lower tier participants is unable to certify to the statements in this certification, such prospective participant shall attach an explanation to this proposal.

The Contractor, _____ certifies or affirms the truthfulness and accuracy of each statement of its certification and disclosure, if any. In addition, the Contractor understands and agrees that the provisions of 2 CFR §180 apply to this certification and disclosure, if any.

Signature of Contractor's Authorized Official: _____

Name and Title of Contractor's Authorized Official: _____

Date: _____

CERTIFICATION REGARDING USE OF CONTRACT FUNDS FOR LOBBYING - 31 USC §1352

[Applicable to all federally assisted contracts and to all related subcontracts which exceed \$100,000]

A bidder must submit to the Authority the below certification with its bid response for any federally assisted contract that exceeds \$100,000. Bids that are not accompanied by a completed certification may be rejected as nonresponsive.

1. The undersigned Contractor certifies, to the best of his or her knowledge and belief, that:

a. No Federal appropriated funds have been paid or will be paid, by or on behalf of the undersigned, to any person for influencing or attempting to influence an officer or employee of any Federal agency, a Member of Congress, an officer or employee of Congress, or an employee of a Member of Congress in connection with the awarding of any Federal contract, the making of any Federal grant, the making of any Federal loan, the entering into of any cooperative agreement, and the extension, continuation, renewal, amendment, or modification of any Federal contract, grant, loan, or cooperative agreement.

b. If any funds other than Federal appropriated funds have been paid or will be paid to any person for influencing or attempting to influence an officer or employee of any Federal agency, a Member of Congress, an officer or employee of Congress, or an employee of a Member of Congress in connection with this Federal contract, grant, loan, or cooperative agreement, the undersigned shall complete and **submit Standard Form-LLL, "Disclosure Form to Report Lobbying,"** in accordance with its instructions.

2. The undersigned also agrees that he or she shall require that the language of this certification be **included in all lower tier subcontracts, which exceed \$100,000** and that all such recipients shall certify and disclose accordingly.

3. This certification is a material representation of fact upon which reliance was placed when this transaction was made or entered into. Submission of this certification is a prerequisite for making or entering into this transaction imposed by 31 USC 1352 (as amended by the Lobbying Disclosure Act of 1995). Any person who fails to file the required certification shall be subject to a civil penalty of not less than \$10,000 and not more than \$100,000 for each such failure.

The Contractor, _____ certifies or affirms the truthfulness and accuracy of each statement of its certification and disclosure, if any. In addition, the Contractor understands and agrees that the provisions of 31 USC 3801, *et seq.*, apply to this certification and disclosure, if any.

Signature of Contractor's Authorized Official: _____

Name and Title of Contractor's Authorized Official: _____

Date: _____

End of Federal Assurances

SCOPE OF WORK

1. **Scope** – Furnish a complete switchgear assembly in accordance with Attachment E – Specifications.
2. **Submittals** – Provide Submittals in accordance with Attachment E – Specifications. Submittals shall be provided to the Authority within 28 days of contract award.
3. **Progress Reports** – Upon commencement of assembly work, progress reports shall be provided to the Authority a minimum of every two weeks. Each report shall be submitted via e-mail to the Authority and the Engineer within two working days of completion of the work period included in the report. Reports shall include at a minimum a brief verbal description of the work completed and adequate photographs to document the work completed.
4. **Programming** – Install SCADA system; install all required software; and program all devices to perform all functions in accordance with Attachment E – Specifications.
5. **Testing** – Perform shop testing of the completed switchgear assembly in accordance with Attachment E – Specifications.
6. **Packaging** – Provide shipping splits and package switchgear in accordance with Attachment E – Specifications.
7. **O&M Manuals** – Provide complete Operation and Maintenance (O&M) Manuals for the switchgear sets in accordance with Attachment E – Specifications.
8. **F.O.B. Point** – Deliver the switchgear to the Alaska Energy Authority, 2601 Commercial Drive, Anchorage, AK 99501.
9. **Delivery Date** – Delivery of the switchgear to the F.O.B. Point is desired within 40 calendar weeks after receipt of an order. On the Bid Schedule provide a firm delivery in calendar weeks where indicated.

Item	Item Description	Quan	Unit	Cost
1	Nelson Lagoon Prime Power Switchgear Complete With SCADA System, Programming, Testing, Crating, Etc.	1	Lump	
Firm Delivery for Switchgear (Calendar Weeks):				

NOTES:

- 1) See Appendix E for equipment specifications.
- 2) See Appendix C for scope of work.
- 3) See Appendix C for F.O.B. point and desired delivery.
- 4) Provide a total cost for entire order.
- 5) Provide a firm delivery in calendar weeks. Note that a firm delivery significantly later than the desired delivery date may cause a bid to be declared non-responsive.
- 6) For a bid to be considered responsive it must include the following:
 - a) This Bid Schedule completed as indicated.
 - b) The completed ITB response (page 1 of the ITB).
 - c) The completed Debarment Certificate, Appendix B, Page B-4.
 - d) The completed Lobbying Certificate Certificate, Appendix B, Page B-5.

PART 1 - GENERAL.....	1
1.1 SCOPE.....	1
1.2 RELATED REQUIREMENTS	2
1.3 SUBMITTALS	2
1.4 QUALITY ASSURANCE.....	3
1.5 FABRICATOR QUALIFICATIONS.....	4
1.6 FABRICATOR WARRANTIES.....	4
1.7 OPERATION AND MAINTENANCE MANUALS	5
PART 2 - PRODUCTS AND ASSEMBLY.....	6
2.1 GENERAL.....	6
2.2 ACCEPTABLE MANUFACTURERS OF SWITCHGEAR COMPONENTS.....	6
2.3 SWITCHGEAR ENCLOSURE.....	6
2.4 PAINTING	8
2.5 CONTROL WIRING.....	8
2.6 BUS BAR	9
2.7 GENERATOR AND DISTRIBUTION CIRCUIT BREAKERS.....	10
2.8 SWITCHGEAR DEVICES	10
2.9 GENSET CONTROL PACKAGE	13
2.10 PROGRAMMABLE LOGIC CONTROLLER.....	13
2.11 OPERATOR INTERFACE UNIT.....	14
2.12 FEEDER PROTECTION RELAY	14
2.13 METERING EQUIPMENT.....	15
2.14 DATA STORAGE SERVER	15
2.15 LOCAL AND REMOTE ACCESS.....	16
2.16 CONTROL POWER	16
2.17 VARIABLE FREQUENCY DRIVES.....	18
2.18 ENGINE/GENERATOR SECTION ASSEMBLY.....	19
2.19 MASTER SECTION ASSEMBLY	21
2.20 DISTRIBUTION FEEDER/VFD SECTION ASSEMBLY	22
PART 3 - PROGRAMMING, TESTING AND PACKAGING	24
3.1 SYSTEM PROGRAMMING AND SOFTWARE INSTALLATION.....	24
3.2 INSPECTION AND WITNESS TESTING	25
3.3 SHOP TESTING	25
3.4 <i>FIELD TESTING</i>	28
3.5 PACKAGING.....	29

PART 4 - MONITORING, CONTROL, AND SEQUENCE OF OPERATION.....	30
4.1 ENGINE MONITORING.....	30
4.2 AMBIENT AIR TEMPERATURE MONITORING	30
4.3 FUEL AND OIL SYSTEM MONITORING	30
4.4 COOLING SYSTEM MONITORING.....	31
4.5 HEAT RECOVERY SYSTEM MONITORING.....	32
4.6 OIU DISPLAY	32
4.7 GENERAL CONTROL SPECIFICATIONS	35
4.8 GENERATION SEQUENCE OF OPERATION.....	35
4.9 FEEDER BREAKER SEQUENCE OF OPERATION	42
4.10 VFD SEQUENCE OF OPERATION.....	42
4.11 HEAT RECOVERY SEQUENCE OF OPERATION	43
SEE ATTACHMENT A, GENSET CONTROLLER SETTINGS TABLE.....	44
SEE ATTACHMENT B, PROJECT DESIGN DRAWINGS	44

ATTACHMENT A - GENSET CONTROLLER SETTINGS TABLE

ATTACHMENT B – PROJECT DESIGN DRAWINGS

LIST OF ABBREVIATIONS

CAC:	Charger Air Cooler
CPU:	Central Processor Unit
CT:	Current Transformer
ECU:	Engine Control Unit
EULA:	End User License Agreement
FPR:	Feeder Protection Relay
GC:	Genset Controller
GPH:	Gallons per Hour
HMI:	Human Machine Interface
kWh:	kilowatt hour
LAN:	Local Area Network
O&M:	Operations & Maintenance
OIU:	Operator Interface Unit
PLC:	Programmable Logic Controller
PT:	Potential Transformer
PSI:	Pounds per Square Inch
RPM:	Revolutions per Minute
SCADA:	Supervisory Control and Data Acquisition
SMS:	System Mode Switch
UL:	Underwriters Laboratory
VAC:	Volts, AC
VDC:	Volts, DC
VFD:	Variable Frequency Drive

SECTION 26 23 00

PRIME POWER LOW-VOLTAGE SWITCHGEAR

PART 1- GENERAL

1.1 SCOPE

- A. The Work shall consist of, but not be limited to, designing, fabricating, testing and providing complete and fully functional switchgear to parallel diesel-generators for prime power generation as indicated on the project design drawings and as specified herein.
- B. The specifications and project design drawings are complementary. What is shown on one is binding whether or not it is shown or specified in the other.
- C. Provide a complete and operational system as specified herein. The components identified shall not be construed to be the complete list of components required for the successful operation of the system as specified. Provide all components and design required for the complete and successful operation of the system, conforming to all the requirements specified herein, whether the components are identified or not. Ensure all devices are installed and operate within their intended purposes. Check all catalog numbers indicated and coordinate all devices installed.
- D. The word "Contractor" as used in this section shall mean the Electrical Contractor responsible for field installation, testing, and commissioning of the system. Note that field installation will be performed under a separate contract and is not part of the scope of work for the switchgear purchase contract.
- E. The word "Fabricator" as used in this section shall mean the company responsible for assembly, wiring, and programming of control equipment and systems.
- F. The paralleling switchgear shall be capable of unattended automatic and manual operation as described herein. The switchgear controls shall be a fully coordinated system that provides the functions and features as specified herein.
- G. The automatic control and overall sequencing, starting, and stopping of the generators (Demand Control) shall be performed by a Programmable Logic Controller (PLC). Failure of the PLC shall not inhibit manual operation, paralleling, and control of the individual engine generators.
- H. Automatic start/stop shall be accomplished through the Genset Controllers (GC). Each generator shall have an electrically operated circuit breaker to perform the normal online/offline paralleling functions of the generator which will be controlled by the GC.
- I. The distribution feeder shall have an electrically operated circuit breaker to perform the normal online/offline functions.
- J. Variable frequency drives shall be provided in the switchgear for radiator fan control as indicated.

- K. The switchgear shall be shop tested separately from the engine generators and field tested with the engine generators as specified herein.

1.2 RELATED REQUIREMENTS

- A. Section 26 23 05 – SCADA System for Switchgear Upgrades

1.3 SUBMITTALS

- A. Provide the submittal in a single electronic file in Adobe Acrobat PDF format.
- B. Provide a bill of material for all equipment or material provided as part of the switchgear.
- C. Provide manufacturer's catalog literature for all accessories and equipment. Literature shall be limited to only the items furnished and shall not include entire sections of catalogs or data sheets for items not used. Items shall be marked electronically such that it is clear which item is for what purpose.
- D. Provide complete and accurate shop drawings of the equipment as specified herein. The current revision, issue number, and date shall be indicated on all drawings and other descriptive data. Provide all drawing files in Adobe PDF format. Upon request, provide drawing files in AutoCAD 2016 format; include all title blocks, external references, special fonts, and plot configuration files such that when plotted the AutoCAD file appears like the PDF file.
 - 1. All drawings submitted shall be drawn to accurate scale on sheets not less than 11" x 17"; except for actual pattern or template type drawings, the maximum sheet size shall not exceed 24" x 36". The preferable sheet size is 22" x 34". Indicate the name of the firm that prepared each shop drawing and provide appropriate project identification in the title block. Do not reproduce contract documents or copy standard printed information as the basis of shop drawings.
 - 2. All drawings shall use standard ANSI symbols.
 - 3. Provide dimensioned drawings showing enclosure construction and arrangement. In addition, show the locations of all major face mounted devices such as meters, GC, OIU, FPR, VFDs, Breakers, etc. and all major internal components such as barriers, bus bars, CT, PT, etc.
 - 4. Provide a one-line diagram, and three-line diagrams for all AC power circuits. The one-line diagram shall show at a minimum: breakers including frame size and trip setting; CT's CPT's, and PT's; protective devices; meters; control devices; and the size and temperature rating of all power conductors. The three-line diagrams shall show additional detail including wire terminations, CT shorting terminals, etc.
 - 5. Provide schematics of all controls. Provide AC three line and DC control schematic diagrams for each generator, feeder, VFD, and master controls. Provide feeder and generator breaker control schematic diagram. Provide 24VDC control power schematic diagrams. Provide 120VAC control power, utility power convenience receptacle, and fan control schematic

- diagram. Schematics shall be in ladder diagram format and shall show all control devices, and wire and external terminal block numbers.
6. Provide a Point I/O communication network schematic diagram showing Point I/O modules with Node Addresses. Identify device location in switchgear.
 7. Provide a communication network (LAN) schematic diagram showing all switches, meters, GC's, OIU, FPR, VFDs, Data Storage Server, PLC, Serial to Ethernet servers and external I/O devices. Identify device location in switchgear. Include IP Address for all devices.
 8. Provide a communication network schematic diagram showing CANbus connection to GC's, and J1939 connection to IKD-1 digital I/O expansion modules and engine ECU's. Identify device location in switchgear.
 9. Provide drawings showing terminal block layouts and interconnecting wiring. The drawings shall show the physical layout of the terminal blocks with their appropriate designations and all connections between terminal blocks, auxiliary switch contacts, control devices, instrumentation, protection devices, etc.
 10. Provide drawings of control switches showing all terminals with numbers, including terminals not used. Identify the use of the terminals.
 11. Provide drawings that show annunciator layouts and nameplate engraving.
 12. Provide the following PLC information: a complete ladder diagram showing all address numbers, rung reference numbers, and all preset register values. Include detailed narrative describing the purpose of each rung. Provide complete tables or schedules listing all utilized I/O addresses, internal relay addresses, and timer, counter, and register addresses and values. Include the latest revision date.
 13. Clearly identify all shipping splits. Provide wiring harnesses for any control wiring required to connect between shipping splits. Drawings shall clearly indicate the wiring harness and connections. Provide terminal blocks between the shipping splits for ease of wiring in the field.
- E. Upon completion of shop testing and prior to shipping, provide test reports documenting compliance with the testing requirements under Part 3.

1.4 QUALITY ASSURANCE

- A. Equipment provided under this section shall not have been in service any time prior to delivery, except as required by testing.
- B. Solid-state circuitry shall meet or exceed the Transient Overvoltage Withstand Test per NEMA ICS1-109 and the Surge Withstand Capability Test (SWC) per IEEE Standard 472 (ANSI C37.90A). In addition, where UL or equivalent standards exist for components, devices, and/or assemblies, such standards shall apply.

- C. Perform all work with skilled craftsman specializing in said work. Install all materials in a neat, orderly, and secure fashion as required by the specifications and commonly recognized standards of good workmanship.
- D. The switchgear shall comply with the requirements of the National Electrical Code for Essential Electrical Systems and shall also comply with applicable standards of NEC, ANSI, IEEE and NEMA.
- E. The switchgear shall also be designed, assembled and tested in strict accordance with UL 891 Standard For Switchboards and UL 508A Standard For Industrial Control Panels or equivalent. The entire switchgear assembly including all accessories shall be listed and labeled as an assembly under UL 891 or equivalent independent testing laboratory standard recognized by the State of Alaska. A nameplate indicating the listing shall be permanently affixed to each section of the switchgear.

1.5 FABRICATOR QUALIFICATIONS

- A. The switchgear shall be designed, assembled, and tested by a qualified fabricator (Fabricator) who is regularly engaged in the business of providing generation switchgear. A list of five prior projects that key staff have worked on may be requested by the Authority after the bid opening and prior to award to verify Fabricator qualifications. The list shall include installation date, description of installation, and a reference contact for each installation.
- B. At the time of bid submittal, the Fabricator shall have current authorization from a third-party listing agency to provide listed switchgear as required by the specifications. Evidence of authorization may be requested by the Authority after the bid opening to verify Fabricator qualifications.

1.6 FABRICATOR WARRANTIES

- A. The Fabricator shall warrant the work for a period of not less than one-year. The warranty period shall commence upon acceptance by AEA of field testing with the engine generators and final commissioning of the equipment.
- B. Provide a nametag on each piece of equipment that clearly identifies the party responsible for the warranty. Nametag shall include the name, address, and phone number, and shop order or Fabricator's serial number.
- C. In the event of a failure of equipment or components or a failure of the system to perform all specified functions during the warranty period, the Fabricator shall repair or replace such defective equipment or components and revise programming and settings as required to achieve full system function. The Fabricator shall assist the Authority as directed to determine the cause of failure and pursue manufacturer's warranties to the extent necessary to obtain replacement equipment and provide proof of action taken upon request.
- D. The Fabricator shall provide up to an additional eight (8) hours of programming assistance and technical support to modify the system programming as requested by the Authority or its Designee(s). These hours are in addition to any technical requirements specified for programming, start-up, and commissioning efforts, and

shall be included in the Fabricator's bid price. The programming assistance and technical support may be required to be provided at a single event or may be spread out over the year as directed by the Authority or its Designee(s), and will be performed remotely from the Fabricator's office and not at the Utility location.

1.7 OPERATION AND MAINTENANCE MANUALS

- A. Provide operation and maintenance (O&M) manuals for all equipment provided under this contract.
- B. The O&M manuals shall be in addition to any instructions or parts list packed with or attached to the equipment when delivered, or any information submitted for review.
- C. The O&M manuals shall include at a minimum the following information:
 - 1. Sequence of operation of the switchgear system.
 - 2. Documentation and operating description of SCADA system.
 - 3. A complete tag list of all input/output devices including, but not limited to, the PLC, GC, and all monitored and controlled devices.
 - 4. Bill of material for all equipment or material provided as part of the switchgear as previously indicated under Submittals.
 - 5. Manufacturer's catalog literature for all accessories and equipment as previously indicated under Submittals.
 - 6. Complete shop drawings as previously indicated under Submittals, revised to reflect as-built conditions of final construction.
 - 7. Complete test reports documenting all shop tests performed in accordance with requirements of Part 3.
- D. The O&M manuals shall consist of a single Adobe Acrobat PDF file and shall be complete with all revisions and as-built data to reflect the actual equipment and material installed. The O&M manual shall be organized as follows:
 - 1. Provide chapters to separate the different components into logical groupings, i.e. sequence of operation, warranty, bill of material, breakers, enclosures, battery system, meters, etc. At the beginning of each chapter, provide a page with the chapter number.
 - 2. Provide subchapters for each individual switchgear item. Bookmark each chapter and subchapter such that each component can be navigated to directly from the bookmark.
 - 3. Near the front of the PDF file, provide the Bill of Material organized so that each item is identified with the chapter or subchapter where the documentation is located.
 - 4. At the end of the PDF file, provide all drawings, inserted horizontally. Provide a chapter for the drawings and individually bookmark each drawing.

- E. Email download link for the final O&M file to the Authority and provide a copy to the Authority on a USB thumb drive.

PART 2 - PRODUCTS AND ASSEMBLY

2.1 GENERAL

- A. All equipment and material furnished shall be new. Equipment furnished and installed under this section shall be fabricated and assembled in full conformity with the project design drawings, specifications, engineering data, manufacturer's instructions, and applicable standards.

2.2 ACCEPTABLE MANUFACTURERS OF SWITCHGEAR COMPONENTS

- A. Specific parts manufacturer and model have been specified in the following paragraphs not only to meet performance function but also to coordinate and interface with other devices and systems. Approved equal substitutions will be allowed only by Authority's approval. To obtain approval, submittals shall clearly demonstrate how substitute item meets or exceeds specified item quality and performance characteristics and also complies with electrical connections and physical layout requirements.
- B. The following products are specified by brand and part number to maintain commonality for programming and service with similar switchgear used in other rural Alaskan communities. Substitutes will not be allowed for the following components:
 - 1. Programmable Logic Controller (PLC): Allen-Bradley.
 - 2. Genset Controller (GC): Woodward or ComAp.
 - 3. Metering Equipment: Shark 250.
 - 4. Feeder Protection Relay (FPR): Schweitzer Engineering Laboratories, Inc.
- C. Acceptable manufacturers of all components not otherwise indicated shall be ABB, Allen-Bradley, Eaton, IDEC, or Square D.

2.3 SWITCHGEAR ENCLOSURE

The following paragraphs describe general fabrication requirements for the switchgear enclosure.

- A. Provide a freestanding enclosure that is shop built, wired, and tested by the switchgear fabricator. Hinged front-opening doors shall provide required access to all components.
- B. The switchgear shall be front access for all control devices. Provide warning labels and source voltage labels.
- C. All switchgear sections shall be dead front type NEMA 12 construction and labeled in accordance with UL-891, or equivalent. The enclosure shall be divided into individual sections and the maximum dimension of each section shall be as indicated on the project design drawings. All sections shall be of equal depth and

front aligned. Each switchgear section shall be a completely self-supporting structure and shall be capable of being rolled, moved or lifted into the installation position and bolted directly to the floor without the addition of floor sills. Individual sections shall be bolted together to form the required arrangement.

- D. The enclosure frame shall be heavy gauge steel of minimum thickness required by listing standard, Hoffman, B-Line, Rittal or approved equal.
- E. Provide each section with an individual hinged door with latches and concealed hinge construction. Latches shall be one of the following.
 - 1. One three-point single handle operated latch.
 - 2. Multiple single-point latches. Doors which are 36 inches or less in height shall have a minimum of two single-point latches; doors which are greater than 36 inches in height shall have three single-point latches.
- F. Provide each section with back and side pans as required for mounting equipment and wiring. Mounting attachments shall be welded studs or other approved methods. No bolts, screws, or other attachment hardware shall be visible from the exterior.
- G. For each generator section provide separate cubicles for control and power using interior barrier panels to ensure isolation of equipment for safety to personnel during service and maintenance or cable pulling. The upper cubicle shall contain the low voltage (120V max) controls. The lower portion shall contain 480V power equipment and ancillary devices.
- H. Power and control cables shall enter from the top. Provide a cable area behind the controls cubicle of each generator section for routing power cables. Provide isolation barriers between each cable area such that each section is completely isolated from any adjacent section. Provide a removable cover plate on top of the cable area large enough to terminate a minimum of 3 each 3" rigid conduits with locknuts and conduit bushings. The removable cover plate shall cover the entire cable area.
- I. The switchgear shall have one master section. The master section door shall swing so the door front is visible from the generator sections. See the enclosure layout on the project design drawings.
- J. The switchgear shall have one feeder/VFD section or multiple sections as indicated.
- K. Where the main bus is not isolated by barrier plates, provide a glastic cover for isolation over the entire length of the bus.
- L. Overall nameplate. Provide an overall nameplate that provides the following information:
 - 1. Fabricator's name, address, and phone number.
 - 2. Fabricator's serial number or project identification.
 - 3. Year of manufacture.
 - 4. Third party listing identification.

5. Rated maximum voltage.
6. Rated bus ampacity.
7. Rated bus interrupting capacity.

2.4 PAINTING

- A. Steel and iron surfaces shall be protected by suitable paint or coatings. Surfaces that will be inaccessible after assembly shall be protected for the life of the equipment.
- B. Surfaces shall be cleaned, prepared and coated in the shop. All mill scale, oxides, and other coatings shall be removed. All metal enclosure parts shall be phosphatized to ensure that the metal is properly degreased and cleaned.
- C. Exposed surfaces shall be finished smooth, thoroughly cleaned and filled as necessary to provide a smooth uniform base for painting and painted with one or more coats of primer and two or more finish coats of alkyd resin machinery enamel or lacquer as required to produce a smooth hard durable finish.
- D. Provide a premium painting system throughout the painting process from initial cleaning to final assembly to assure a superior paint finish. All coatings shall be applied using an electrostatic paint system.
- E. The color of the exterior panel finish coats shall be ANSI 61 light gray. The color of the interior back and side pans shall be white.

2.5 CONTROL WIRING

- A. All control wiring for the switchgear shall be minimum 600-volt, copper 16-gauge, strand type SIS wire or equivalent. The Fabricator shall be responsible for sizing the appropriate wire for each component and circuit. Current transformer wiring shall be 12-gauge wire.
- B. Terminate all wiring on terminal blocks or devices. No more than two wires shall be connected to a termination point. Terminal blocks for control wiring shall be 20 amp, 600 volt. Provide all terminal blocks and exposed relays located in the controls compartment with a plastic safety cover. Terminal blocks for DC circuits shall be separated from terminal blocks for 120VAC.
- C. Wiring shall be installed in a neat and orderly manner in horizontal and vertical wiring troughs or channels with removable covers for easy accessibility. Wire bundles, when required shall not exceed one (1) inch in diameter. Adhesive backed Ty-Rap bases shall not be used to support bundles. All wiring bases shall be securely attached with metal screws.
- D. Extra flexible stranding wires shall be used in areas subject to flexing, such as areas where hinged brackets or swing racks/doors are used.
- E. Only one wire shall be inserted into a lug. Install lugs with a ratcheting type crimping tool. Tag all wires with wire markers at both ends.
- F. Splicing of control, CT, or PT wires is not allowed.

- G. All control wiring landing on screw terminals shall have solderless terminals, ABB Sta-Kon or approved equal. Solderless terminals for current transformer leads shall be insulated ring-tongue type, all others shall be insulated fork-tongue type. All lugs and solderless terminals shall be tin-plated copper.
- H. Wire current transformer leads to shorting type terminal blocks. Shorting pins shall be provided with storage locations for the shorting pins.
- I. Provide terminal blocks for control wires that run between the switchgear and external equipment and devices. Clearly label terminal blocks to match the designation shown on the Fabricator's drawings. Provide a separate terminal strip for interconnection with each generator. The generator terminal strip shall be arranged and numbered exactly as shown on the project design drawings.
- J. Both ends of each wire shall be identified per the marking and numbering shown on the wiring drawings with heat shrink or wrap-around adhesive labels.
- K. All ground wires shall have green insulation. Note that wires larger than #6 may be marked with green tape.

2.6 BUS BAR

- A. Provide silver-plated copper main bus bars. Size the main bus to meet the ampacity indicated on the project design drawings. If the actual ampacity of the bus installed exceeds the design value, the switchgear bus shall be rated as indicated on the project design drawings.
- B. The main bus shall be well braced to meet the short circuit ratings of the generators. Minimum bus bracing shall be 30,000 amperes symmetrical, unless indicated otherwise on the project design drawings. The main bus shall be installed on insulators to provide proper clearances between phases and phase to ground.
- C. Provide an isolated copper neutral bus rated the same as the main bus. The neutral bus shall have a single removable connection to the ground bus. The connection shall be accessible in the feeder section.
- D. Provide a bonded copper ground bus minimum size 2" x 1/4", or as required for the bus ampacity.
- E. Horizontal bus joints between each section shall be silver-plated copper. Bus joints shall be bolted with high tensile steel bolts with spring loaded Belleville type washers.
- F. A-B-C type bus arrangement (left-to-right, top-to-bottom, front-to-back) shall be used throughout to assure convenient and safe testing and maintenance.
- G. Provide termination bars on the load side of the feeder breaker and on the line side of the generator breakers for termination of field wiring. Provide holes in the termination bars for field connection of lugs suitable for termination of #4/0 AWG cables, minimum 2 for each phase. Provide additional holes where specifically indicated.

- H. The feeder, generator, VFD, and station service circuit breakers shall be connected to the main bus by cables. All cables and connections shall be rated for the full ampacity of the circuit breaker frame.

2.7 GENERATOR AND DISTRIBUTION CIRCUIT BREAKERS

- A. Provide each generator and distribution feeder with an electrically operated stationary mount type circuit breaker. Circuit breakers shall be ABB SACE E-Max, Eaton Magnum DS, Square D Masterpact NT, or approved equal.
- B. Circuit breakers shall be designed for continuous operation at 100% of the circuit breaker rating. Circuit breakers shall be suitable for power flow in either direction through the breaker.
- C. Minimum interrupting rating of breakers shall be 50,000 amperes symmetrical.
- D. Provide breaker frame size as indicated on the project design drawings.
- E. A protective trip element is not required, as protection will be provided by the GC for the generator breakers and by the FPR for the distribution feeder breaker.
- F. Provide circuit breakers with the following features:
 - 1. Three-pole stationary mount.
 - 2. Remote open/close.
 - 3. Shunt trip.
 - 4. 24V DC control voltage.
 - 5. 120V AC spring charging motor for automatic recharging of the breaker stored energy mechanism. The stored energy mechanism shall be capable of an open-close-open cycle without recharging.
 - 6. Anti-pumping feature.
 - 7. Manual spring charging mechanism.
 - 8. Mechanical operation counter.
 - 9. Auxiliary switch module.
 - 10. Lockable push button cover

2.8 SWITCHGEAR DEVICES

- A. Nameplates. All nameplates shall be black with white core type. Nameplates shall have beveled edges and shall be secured with a minimum of two mounting screws. Provide nameplates for each device on the front of the switchgear and inside the switchgear. Inside the switchgear compartments, all relays, control switches, lights, etc. to which control or instrument transformer wiring connects, shall be marked by nameplates, with designations corresponding to the same device designations used on the wiring drawings and approved by the Authority. Nameplates inside the switchgear located on the front doors may be attached using adhesive epoxy.

Relays shall have the nameplates installed separate from the relay such that the relay can be removed without affecting the nameplate. Route all wiring such that it does not inhibit the visibility of the nameplate or interfere with the removal of the relay.

- B. Selector Switches. Selector switches shall be heavy-duty metal type. Contacts shall have silver butting or sliding contacts, rated 10 amperes continuous at 120 volts AC. Contact configuration shall be as required for the application. Legends shall be engraved on the switch nameplate. Unless otherwise specified, all selector switches located on the front of the enclosure shall be Electroswitch Series 24 or approved equal.
 - 1. System Mode Switch. AUTO/MAN ISOCH, Two-position lever operated maintained contact. Electroswitch 24201C or approved equal.
 - 2. Feeder Breaker Control Switch. TRIP/ /CLOSE Three-position lever operated momentary contact spring return to center, Electroswitch 2438D or approved equal.
- C. Generator Lockout Switch (GLS). Key operated maintained contact OFF/RUN switch with normally closed contact. Allen Bradley 800FM-KM21 with metal latch 800F-ALM, Eaton Series 10250T1511-2, or approved equal.
- D. Reset/Test Buttons. Push type momentary contact, normally open, 30 mm, non-illuminated, flush mount with heavy duty metal latch. Allen Bradley Series 800T-A, Eaton Series 10250T10, or approved equal. Color as indicated. Provide contact blocks as required.
- E. Emergency Stop Button. Red push/pull maintained normally closed late-break contact with protective finger safe guard and yellow emergency-stop ring. Allen Bradley 800T-FX6D4 operator, with 800T-NX1320 black guard, 800T-X646EM E-Stop ring and 800TC-XD1 normally open finger safe contact block, or approved equal.
- F. Annunciator Lights. LED cluster type panel mount lamps, 24 VDC. IDEC Corp. Series SLC40, APEX Automation Solutions L7525 series, or approved equal.
- G. LED panel illumination kit with motion sensor, 24VDC. Rittal 2500320, STEGO 025411-10, or approved equal.
- H. Convenience receptacle. 120 volt duplex receptacle, din rail mount, 15 ampere rating, GFI. Phoenix Contact 5600462, or approved equal.
- I. Control Relays/Time Delays. Relays and timers for control operations or isolation shall be of the plug-in socket base type with dustproof plastic enclosures unless noted otherwise. Relays and timers shall be UL recognized, have 120-volt AC or 24-volt DC coils, depending on the application. Relays shall not have less than double-pole, double-throw contacts. Control circuit relays shall have silver-nickel contacts rated for 10 amperes at 120 volts AC. Relays utilized for PLC input, alarm input or indicating light service shall have contacts rated not less than 3 amperes. Provide all relays and timers with indicating lights. IDEC Corp., Phoenix Contact, or approved equal.

1. Relays for use on 24-volt DC circuits shall be provided with different bases than those for use on 120-volt AC circuits to prevent inadvertent swapping of relays.
 2. Auxiliary power relays shall be Allen-Bradley series 700, minimum 20A rated, or approved equal.
 3. Dead bus relay shall be IDEC RR3BUL-AC120V with SR3B-05 base, or approved equal.
 4. Time delay relay shall be Crouzet 88867105, or approved equal
- J. Circuit Breakers.
1. Protective devices shall be resettable circuit breakers for all AC and DC circuits in the switchgear. Replaceable fuse type devices are not acceptable.
 2. Circuit breakers shall be molded case type of the amperage, voltage, short circuit capacity, and number of poles required for the application or as indicated on the one-line diagram.
 3. Provide manually operated molded case circuit breakers to protect the branch power circuits of the variable frequency drives (VFDs). The breakers shall be sized and connected as indicated on the one-line diagram on the project design drawings, and as specified herein. Provide each breaker with a shunt trip.
 4. Provide manually operated molded case circuit breakers to protect the station service transformer and other branch circuits as indicated on the one-line diagram on the project design drawings. The breakers shall be sized and connected as indicated, and as specified herein. Mount the breakers in the face of the switchgear with a protective guard and provide auxiliary contacts to indicate position. Wire the closed position contact to the PLC to provide alarm indication any time the breaker is not closed (either tripped or manually opened).
- K. Current Transformers. Instrument current transformers shall be specifically designed for installation in switchgear. The design shall coordinate the thermal, mechanical, and insulation limits of the current transformers with those of the breakers and bus of the switchgear. Provide current transformers of the window type with brass stud terminals. Insulation shall be suitable for 600 volt service at 60Hz.
1. Current transformers for relay service - minimum C20 accuracy class with a rating factor of 2.0.
 2. Current transformers for meters shall be metering class with a rating factor of 1.5. For CT ratios 200:5 and greater, provide 0.3% accuracy or greater with a burden rating of B0.1. For CT ratios less than 200:5, provide 1.2% accuracy or greater with a burden rating of B0.1.
 3. Multi-ratio Current transformers - provide ratio as indicated with the accuracy specified at full distributed windings.

4. The CT burden shall be suitable for the devices attached without saturating.
5. All CT's shall be provided with shorting type terminal blocks complete with shorting pins.
- L. Potential Transformers. Provide minimum 150VA instrument rated potential transformers, quantity and ratio as indicated on the project design drawings. Provide primary and secondary protection using circuit breakers.
- M. Control Power Transformers. Provide control power transformers for circuit breaker trip mechanism charging. Minimum 500VA or size required for circuit breakers provided, quantity and ratio as indicated on the project design drawings. Provide primary and secondary protection using circuit breakers. Provide with finger safe terminal covers.
- N. Ambient Air Temperature Sensors. Provide moderate temperature range, 3-wire, platinum RTD, 100 ohms +/- 0.15%, @ 0°C tolerance. For indoor use provide Prosense RTD1-R01-01 with plastic vented housing, or approved equal. For outdoor use, provide Prosense RTD1-C06-01, NEMA 4X, or approved equal.

2.9 GENSET CONTROL PACKAGE

The basis of design is the Easygen as specified below. The only acceptable substitute is a ComAp IntelliGen 500. If using the ComAp, furnish equivalent modules and accessories as required to provide all features and perform all functions as specified for the Easygen.

- A. Genset Controller (GC). Door mounted style with display face, Woodward Easygen Model 3200XT-P1, Part Number 8440-2082, or ComAp IntelliGen 500.
- B. Easygen IKD-1 digital I/O expansion module, 8 inputs, 8 outputs. DIN rail mounting, 24V DC. Woodward 8440-2028, or ComAp equal.
- C. Signal Converter. Multi-input, 4-20mA / 0-10VDC Output. Provide for isolation protection of Easygen analog inputs. Omega DR-I3P, Prosense SCU-1600 or approved equal. Provide minimum one (1) Signal Converter Programming/Display Module SCU-PDM1 with SCU-1600.
- D. Additional items, components, or wiring that may be required for a complete and operational system as specified herein.

2.10 PROGRAMMABLE LOGIC CONTROLLER

- A. Programmable Logic Controller. Allen-Bradley, CompactLogix 1769, no substitutes. Provide the following:
 1. 24VDC power supply. Allen-Bradley 1769-PB4.
 2. CPU (2 Mb Memory, Ethernet). Allen-Bradley 1769-L33ER.
 3. Right End Cap/Terminator. 1769-ECR.
 4. Point I/O Modules, 24VDC, as required which may include the following:
 - a. 8 point digital input module, sinking. Allen-Bradley 1734-IB8.
 - b. 8 point digital output module, sourcing. Allen-Bradley 1734-OB8.

- c. 2 point analog input module, 4-20mA. Allen-Bradley 1734-IE2C.
 - d. 2 point analog output module, 4-20mA. Allen-Bradley 1734-OE2C.
 - e. 2 point RTD input module. Allen-Bradley 1734-IR2.
 - f. EtherNet/IP adapter. 24VDC power. Allen-Bradley 1734-AENT.
 - g. 24VDC power extension module. Allen Bradley 1734-EP24DC.
5. Provide additional items as may be indicated on the project design drawings or required for the proper and complete operation of the system as specified.
- B. Provide cables, connectors, and interface devices as required for a complete and operational system.
- C. All I/O devices shall be connected in an EtherNet/IP network star topology configuration.

2.11 OPERATOR INTERFACE UNIT

- A. Operator Interface Unit (OIU). A human machine interface (HMI) referred to herein as OIU shall be installed on the front of the switchgear master section door. The OIU shall be an integrated touch screen display computer with solid state drives, Logic Supply CV-115C-P1101, or approved equal. The OIU shall meet the following minimum requirements:
1. 15" display with minimum of 1024 x 768 pixel resolution.
 2. LCD Color: 16.2M, Pixel Pitch (mm): 0.297 (H) x 0.297 (V).
 3. Projected Capacitive Touch.
 4. Intel Apollo Lake Processor N4200 Quad Core. 4 GB SO-DIMM DDR3L 1866MHz memory, 64 GB SATA Solid State Hard Drive, Compact Flash Drive.
 5. 3 USB 2.0 Ports, 1 USB 3.0 port, 10/100M Ethernet Port, serial port.
 6. 24VDC power supply.
 7. Windows 10 Professional, 64 bit.
 8. Passive cooling without fan.

2.12 FEEDER PROTECTION RELAY

- A. Feeder protection shall be provided by the Feeder Protection Relay. Feeder protection relay (FPR) shall be Schweitzer Engineering Laboratories, Inc. model SEL-751A, no substitutes. The Fabricator shall determine complete FPR settings for each feeder in accordance with the Feeder Sequence of Operation that follows. Fabricator shall develop the actual configuration part number to provide a relay that meets all requirements as follows.
1. Under/over frequency.
 2. Under/over voltage.

3. Instantaneous overcurrent (phase/neutral).
4. Time overcurrent (phase/neutral).
5. Residual instantaneous overcurrent.
6. Residual time overcurrent.
7. Neutral instantaneous overcurrent.
8. Neutral time overcurrent.
9. The FPR shall also be provided with the following additional features:
 - a. EIA-232 Rear and Single 10/100BASE-T Ethernet.
 - b. 24V DC power supply and input.
 - c. DI/DO as required to meet the requirements of the specifications.
 - d. Three-phase voltage and current input. Five amp current.
 - e. Synchronism check element.
 - f. Metering to include the following:
 - Voltage, L-L and L-N.
 - Current; three phase and neutral.
 - Percent voltage imbalance.
 - Apparent power (kVA).
 - Real power (kW).
 - Reactive power (kVAR), positive or negative.
 - Power factor.

2.13 METERING EQUIPMENT

- A. Bus Meter. Class 10 current inputs, 120VAC input, 18-60VDC power supply. Provide with Ethernet communications port, panel mount remote display module, cable, and optional 4-20mA I/O card. SHARK 250-60-10-V2-D-INP100S-20mAOS, no substitutes.
- B. Station Service Meter. The station service meter shall be identical to the bus meter except without the optional 4-20mA I/O card. SHARK 250-60-10-V2-D-INP100S-X, no substitutes.
- C. Provide all cables, connectors, and other devices including CT shorting terminal blocks as required for a complete and operational metering system.

2.14 DATA STORAGE SERVER

- A. An industrial fanless mini PC shall be installed in the switchgear master section. The mini PC shall be as follows:
 1. Processor: Intel Core i7-1165G7 up to 4.7GHz
 2. Ram: 16 GB, SO-DIMM DDR4 3200MHz (non-ECC)
 3. Hard drive: minimum 512 GB M.2 NVMe SSD

4. Auto Power On
 5. Dust Filter for Small Form Factor
 6. Windows 10 Professional, 64 bit
 7. DIN Rail Mounting Kit or Mounting as required
 8. 60W 12VDC Power Supply
 9. OnLogic ML100G-53, or approved equal.
- B. Furnish and install all cables and interface devices required for a complete and operational system plus any additional devices that may be required to be fully functional and meet the requirements of these specifications.

2.15 LOCAL AND REMOTE ACCESS

- A. Provide the switchgear with an Ethernet connection for access to the switchgear LAN via high speed internet. See Summary of Work, Section 01 11 13, for internet service requirements.
- B. Industrial Ethernet Switch. 16 port, Unmanaged, 10/100/1000 MBPS, 24VDC Ethernet switch, Phoenix Contact FL SWITCH 1116 or approved equal. All equipment shall be connected to provide seamless communication between the PLC, LAN devices and the Ethernet connection to the Internet. Provide multiple switches for systems requiring more than 16 ports.
- C. Secure Serial to Ethernet Server. Configured to support RS-232, RS-422, and RS-485 with two pin power terminal connector. NetBurner SB800EX-TDD-IR or approved equal with DIN 200 mounting bracket. Program to boot without use of SD card.
- D. The data storage server shall store historical and real time data from the PLC and Bus and Station Service Meters, and shall provide the primary means for remote access via LogMeIn for data retrieval, remote monitoring, and device programming access.
- E. All devices on the switchgear LAN shall be remotely accessible via the internet for system monitoring, data acquisition, and troubleshooting. Remote access shall allow a technician in another location to modify and/or view all operational screens and all logic in the PLC, as well as the GCs, FPR, VFDs, Data Storage Server, Serial to Ethernet Server(s), metering equipment and LAN Router.
- F. Provide communications connections as required for the proper operation and control of the systems.

2.16 CONTROL POWER

- A. Control power for the switchgear shall be 24VDC, except where specifically indicated otherwise. All meters and other components requiring auxiliary power to operate shall operate from the 24VDC control power source, unless otherwise specified. All control circuits shall be 24VDC.
- B. Provide a complete 24VDC power supply with redundant secondary backup. Include all items described below plus all other components required for a

complete system. The primary source shall be a 120VAC to 24VDC power supply using 120VAC station service power. The secondary source shall be from a 24VDC-24VDC battery buffer module using power from 24VDC engine batteries. The 24VDC control power system shall include the following major equipment:

1. Primary Power Supply. 100-240VAC primary input, minimum 20 amp, 24VDC output at 45°C. PULS CP20.241-S1, or approved equal. Install in the master section. Set output to 26 VDC to ensure it operates as the primary source when AC power is available.
 2. Battery Buffer Module. 22-29VDC input, minimum 15 amp, 24VDC output. The module shall include capacitors to buffer power during engine crank cycles with a minimum capacity of 15A for 9 seconds. Siemens 6EP1933-2EC51, or approved equal. Install module in the master section.
 3. Power Bridge Rectifier. 35A minimum 35A. Powersem PSB-35/08 or approved equal.
- C. The DC power from the engine batteries shall enter in the respective generator section. A 20A circuit breaker shall be installed on the battery power supply.
- D. The 24VDC outputs from each generator section shall be connected to the 24VDC input on the battery buffer module in the master section through power bridge rectifiers, quantity as required for the number of inputs.
- E. The 24VDC outputs from the Primary Power Supply, the Battery Buffer Module, and the engine batteries shall be connected together in the master section through power bridge rectifiers. The power sources shall be coordinated to automatically switch from the 120VAC source to the 24VDC source upon loss of AC power and automatically switch back when the AC power is restored. The system shall provide continuous power without interruption prioritized as follows:
1. Primary Power Supply (120V AC Source - Primary).
 2. Battery Buffer Module (24V DC Source - Secondary).
 3. Engine Batteries (in the event of a fault of the Battery Buffer Module).
- F. The 24VDC power supply to each switchgear section (master, generator, and feeder/VFD) shall be isolated through a 15A circuit breaker in each respective section.
- G. Each major device or meter shall be individually protected by circuit breakers. Clearly mark each circuit breaker for the intended service.
- H. 120VAC Circuit Breaker Charging - Power for the distribution feeder circuit breaker spring charging motor(s) shall be derived from a control power transformer connected to the main bus. Power for the generator circuit breaker spring charging motors shall be derived from a control power transformer connected on the generator side of the circuit breaker.
- I. 120VAC Control and Utility Power – Provide 2 sets of terminals for connection of incoming 120VAC power, 20A, single phase. One shall be for utility power and one for control power as indicated. The 120VAC system shall include:

1. Utility Power – One circuit shall provide power for ventilation fans and convenience receptacle.
2. Control Power - One circuit shall provide power to the UPS and to the 120VAC to 24VDC Primary Power Supply. No other devices shall be connected to this circuit. Provide a 15A circuit breaker to serve the UPS and a 10A circuit breaker to serve the Primary Power Supply.
3. UPS – Rack-mount UPS shall be complete with a sealed leak-proof maintenance free lead acid battery. It shall be 120V, 60Hz, 15A input and 120V, 60Hz, 1500VA output. Tripp-Lite SMART1500LCD, APC SMT 1500C or approved equal.
4. The UPS shall be installed in the master section and shall be connected to provide 120VAC power to the data storage server.

2.17 VARIABLE FREQUENCY DRIVES

- A. Provide the following VFD section components:
 1. Main circuit breaker. Manually operated molded case circuit breaker, 15A, 3 pole. Allen Bradley 1489-M3D150, or approved equal. Furnish with auxiliary contacts and shunt trip.
 2. VFD Selector Switch. Three-position lever-operated maintained contact switch to select between VFD /OFF/BYPASS operating modes. The switch shall be rated for occasional switching of motors of the size and voltage indicated, and be padlockable in the OFF (12h) Position. Salzer Part # H216-71322-013V1, Allen Bradley 800T-J17A, or approved equal. Furnish with a minimum of 4 each (2 N.O. & 2 N.C.) auxiliary contacts.
 3. Variable Frequency Drive. Square D Altivar ATV320U40N4B, or approved equal, complete with the following features and accessories:
 - a. UL listed.
 - b. Sized for continuous operation of 5 hp motor.
 - c. Ramp regulation, flying start, and step logic.
 - d. Built-in PID control using 4-20 mA signal as the control variable.
 - e. Sensorless vector slip compensation.
 - f. Motor protection including overload protection, short circuit protection, ground fault protection, and under & over voltage protection.
 - g. 1:100 speed range.
 - h. RS-485, ModBus protocol.
 - i. 4-20 mA analog input.
 - j. Four assignable logic inputs.
 - k. Two relay logic outputs.

- l. Remote Graphic Display Terminal. Square D VW3A1101, or approved equal.
 - m. Remote Graphic Display Mounting Kit. Square D VW3A1102, or approved equal.
 - n. Modbus TCP/IP Ethernet communications card. Square D VW3A3616, or approved equal.
 - o. Cables and connectors as required.
4. Contactor for normal run operation. VFD isolation contactor, 3-pole, 600V, minimum 16A with 24VDC coil. Allen-Bradley model 100-C16EJ10, or approved equal. Furnish with one normally open auxiliary contact.
 5. Adjustable solid-state overload relay, 480-volt, 3-phase, adjustable range. Allen-Bradley model 193, or approved equal, complete with din rail adapter.
 - a. For motor sizes 2 HP and smaller provide 1.0-5.0A trip range.
 - b. For motor sizes 3 HP and 5 HP provide 3.2-16A trip range.
 6. Cooling fan, with filter and grille, sized to keep the VFD operating within its temperature limitations based on a 100° F ambient temperature.

2.18 ENGINE/GENERATOR SECTION ASSEMBLY

- A. Provide the following components for each generator section as required to allow automatic or manual operation and control of each generator.
 1. Genset Controller (GC). The GC shall communicate to the PLC via Modbus TCP and Point I/O blocks. The top of the GC screen shall not exceed 60" above the bottom of the switchgear.
 - a. Signal Converter. Provide a signal converter on Analog Inputs 1 thru 3, to provide isolation and protection
 - b. EasYgen IKD-1 digital I/O expansion module. Provide as needed to meet the functional requirements of the system.
 2. Generator Lockout Switch. Provide a key operated OFF/RUN switch mounted in each generator control section door. All switches for the entire project shall utilize a common key. Provide two keys for each generator section.
 3. Alarm Reset. Provide an Alarm Reset push button that resets all GC alarms after the alarm condition has been corrected.
 4. Service Hours Reset. Provide a Service Hours Reset push button that resets the timer for engine service (oil change) intervals.
 5. Generator Circuit Breaker.
 6. Current Transformers for relaying.
 7. Potential Transformers.

8. Control power transformer for spring charging motor.
9. 24VDC 15A circuit breaker for control power.
10. LED panel illumination kit, complete with motion sensor.
11. Provide Terminal Blocks, Relays, Timers, Bases, as needed.
12. Generator breaker Status Annunciation LEDs (mount immediately below Generator Lockout Switch):
 - a. Generator “#” Breaker Closed (red)
 - b. Generator “#” Breaker Open (green).
13. Provide annunciation LED’s, mount near top of cabinet, left to right:

Top Row

- 1) Engine Running (green).
- 2) Alarm/Lockout (red).
- 3) Low Oil Pressure (red).
- 4) Oil Level (red).
- 5) High Coolant Temperature (red).
- 6) Over Speed (red).
- 7) Over Crank (red).
- 8) Running Timeout (red).
- 9) Battery Charger Failure (red).
- 10) Air Filter Plugged (red)
- 11) High Exhaust Temperature (red).
- 12) Spare.

Second Row

- 1) Lead Engine (green). Note that this is only for units with two or more identical size engines. See Note 1.
- 2) Normal Stop (amber).
- 3) Not in Auto (red).
- 4) Service Engine (red).
- 5) Fail to Synchronize (red).
- 6) Over Current (red).
- 7) Under Voltage (red).
- 8) Over Voltage (red).
- 9) Under Frequency (red).
- 10) Over Frequency (red).

- 11) Reverse Power (red).
- 12) Spare.

Note 1: For sections that do not require a specific lamp such as Lead Engine provide spare lamp with blank nameplate.

2.19 MASTER SECTION ASSEMBLY

- A. Provide the following components in the master section:
1. PLC.
 2. OIU.
 3. Bus Meter.
 4. Station Service Meter.
 5. Data Storage Server.
 6. Control Power Supply, 120VAC / 24VDC.
 7. Battery Buffer Module.
 8. Uninterruptable Power System (UPS)
 9. Secure Serial to Ethernet Server.
 10. Dead bus relay.
 11. Industrial Ethernet Switch, minimum quantity two.
 12. System Mode Switch, AUTO / MAN ISOCH.
 13. Emergency Stop Button.
 14. A single RESET push button that manually resets all master section alarms.
 15. A single LAMP TEST push button that tests all master section and engine generator section annunciation LEDs simultaneously. Note that this includes all master and generator section lamps but does not include VFD lamps.
 16. Terminals and circuit breakers for switchgear control and utility power.
 17. LED panel illumination kit, complete with motion sensor.
 18. Convenience receptacle, 120 volt duplex GFI receptacle, din rail mount, 15 ampere rating.
 19. Terminal Blocks, Relays, Timers, Bases, as required.
 20. Spare Input: Provide a minimum of 2 spare PLC discreet input pairs wired to terminal blocks.
 21. Spare Output: Provide a minimum of 2 spare two-pole relays wired to terminal blocks and controlled by PLC.
 22. Master annunciation LED's, mount near top of cabinet, left to right:

Top Row

- 1) Fire Alarm (red).
- 2) Emergency Stop (red).
- 3) Low Coolant Level (red).
- 4) Fuel Level (red).
- 5) PLC/ Point I/O Failure (red).
- 6) System Not In Auto (amber).
- 7) Station Service Breaker Open (red).
- 8) VFD Main Breaker Open (red).
- 9) Feeder Breaker Trip (red).
- 10) Feeder Fail To Close (red).

Second Row

- 1) Spare (red).
- 2) Spare (red).
- 3) Spare (red).
- 4) No Load On Heat Recovery (amber).
- 5) Heat Recovery Loss Of Pressure (amber).
- 6) Heat Recovery Loss Of Flow (amber).
- 7) High Coolant Return Temp (red).
- 8) Spare (red).
- 9) Spare (red).
- 10) Spare (red).

- B. Provide two ambient air temperature sensors, one for outside air temperature and one for inside air temperature. Temporarily secure in the master section for shipping. Final field installation shall be outside the switchgear.

2.20 DISTRIBUTION FEEDER/VFD SECTION ASSEMBLY

- A. Provide the following feeder components:
1. Feeder Circuit Breaker.
 2. Feeder breaker Status LED indicating lights (mount immediately above feeder breaker control switch):
 - a. Feeder Breaker Open (green).
 - b. Feeder Breaker Closed (red).
 3. Control power transformer for spring charging motor, size as indicated on the project design drawings.

4. Feeder protection relay (FPR).
 5. Feeder breaker manual control switch, open/close spring return to center.
 6. Current Transformers, quantity and size as indicated on the project design drawings. Provide with shorting terminal blocks.
 7. Potential Transformers, quantity and ratio as indicated on the project design drawings.
 8. 24V DC 15A circuit breaker for control power.
 9. LED panel illumination kit, complete with motion detector.
 10. Circuit breakers for station service and VFD branch circuits, manually operated, with auxiliary contact, sized as indicated on the project design drawings.
- B. Provide the following VFD components. Locate the variable frequency drives (VFD's) above the feeder breaker section(s) as indicated on the project design drawings.
1. Circuit breaker. Manually operated molded case circuit breaker, 15A, 3 pole. Furnish with auxiliary contacts and shunt trip. Auxiliary contacts shall indicate breaker position. Wire the closed position contact to the PLC to provide alarm indication any time the breaker is not closed (either tripped or manually opened). Wire the shunt trip to the overload.
 2. VFD Selector Switch. Three-position VFD/BYPASS/OFF.
 3. VFD.
 4. Contactor for normal run operation. Connect to the load side of the VFD.
 5. Overload relay. Connect to function in both VFD and Bypass modes. Wire into breaker shunt trip.
 6. Nameplate on the door above the indicator lights identifying the VFD for Radiator No. 1, etc.
 7. LED indicating lights, left to right.
 - Top Row
 - 1) VFD Mode (green).
 - 2) VFD Running (green).
 - 3) Bypass Mode (amber).
 - Second Row
 - 1) VFD Fault (red).
 - 2) VFD Breaker Open (red).
 - 3) Spare (amber).
 8. Cooling fan, with filter and grille. When more than two VFDs is installed in a common enclosure install a minimum of two fans. Mount fan(s) at top or bottom of enclosure and provide an exhaust grille in the opposite

- location, on the front of the enclosure. Remove filter from grille. Fan(s) shall run continuously when station service power is on.
9. Provide a single control wiring harness for control from the master section. Provide a single cable connection for VFD power from the bus through the VFD main circuit breaker.
 10. LED panel illumination kit, complete with motion detector.
 11. Install terminal blocks in a single location near the top of the VFD enclosure for field connection of all external control and power wiring for all VFD's. Use shielded wiring or separate routing for conductors on the load side of all VFDs.
 12. Provide power for radiator control and temperature sensors from the 24VDC switchgear control power.
 13. Provide ambient air temperature sensor permanently installed within the VFD section. For systems with more than one VFD section, provided one sensor in each section.

PART 3 - PROGRAMMING, TESTING AND PACKAGING

3.1 SYSTEM PROGRAMMING AND SOFTWARE INSTALLATION

- A. The Fabricator shall furnish and install the following software on the Data Storage Server. All licenses shall be in the name of the Alaska Energy Authority
 1. AB Studio 5000 Mini Edition EN License (PLC programming software).
 2. Woodward Toolkit Easygen (GC configuration software) or ComAp equal.
 3. Schweitzer AcSELeRator. (FPR software, latest version).
 4. Square D (SOMOVE). Or software for VFD provided.
 5. SHARK metering software (latest version).
 6. LogMeIn (AEA will provide installation credentials)
 7. Any other devices installed in the switchgear that have custom software.
- B. The Fabricator shall provide all PLC and GC programming as required to meet the requirements and intent of this specification.
- C. The Fabricator shall prepare a complete tag list of all input/output devices including, but not limited to, the PLC, GC, and all monitored and controlled devices. The Tag List shall be in the form of a spreadsheet. If additional I/O or tags are requested by the Authority the Fabricator shall provide that information. The tag list shall be used in the development of the SCADA system. A copy of the final tag list shall be included in the O&M Manual.
- D. The Fabricator shall install the SCADA software as specified in 26 23 05.
- E. The Authority will provide a list of usernames and passwords for the Fabricator to install on the system.

- F. Upon completion of testing, archive at a minimum the following files on the server:
 - 1. The original licensed copy of each software package.
 - 2. The End User License Agreement (EULA).
 - 3. Final setup files for the CG (Woodward wset), FPR (Schweitzer AcSELeRator QuickSet), VFD, and Meters.
 - 4. Final PLC programming.
 - 5. Final Tag list.
- G. Provide an identical copy of all archived files on a USB thumb drive.

3.2 INSPECTION AND WITNESS TESTING

- A. The Authority shall have the right to inspect, at the shop, all equipment covered by these specifications any time during manufacture and assembly and to be present during any equipment tests.
- B. The Authority may visit the manufacturing facility for final performance testing. The Fabricator shall make a technician available to the Authority to assist in the inspection and witness test of the switchgear. The technician shall instruct the Authority in all functions of the equipment.
- C. The Fabricator shall notify the Authority two weeks in advance of the scheduled test date. Fabricator shall not ship equipment without approval by the Authority of the shop test reports. If the Fabricator ships the equipment without allowing the Authority to witness testing of the equipment, or before the Authority accepts the equipment test, the Authority reserves the right to have a third party test the equipment in Anchorage, Alaska or at the F.O.B. destination. All costs associated with a third-party test shall be deducted from the final payment. If the switchgear fails any test, the Fabricator shall be responsible for correction of all deficiencies, retesting, and proving the switchgear operates as specified and meets the requirements of these specifications with no increase in the contract price.

3.3 SHOP TESTING

- A. Prior to shipping, the Fabricator shall perform shop tests at the shop where the switchgear is assembled. Provide certified copies of all manufacturers' test data and results. Test procedures shall conform to ASME, IEEE, and ANSI standards, and NEMA standard practices section on testing, as appropriate and applicable.
- B. The Fabricator shall provide all required equipment and measuring and indicating devices required to perform the tests indicated. All devices shall be certified correct or correction data furnished for the device.
- C. The Fabricator shall calibrate and set all protective devices.
- D. Tests shall indicate satisfactory operation of specified performance. If the Authority elects to witness the testing, prior to actual witness testing by the Authority, the Fabricator shall conduct sufficient tests and provide the test reports

to the Authority to ensure that when the witness test is performed, the equipment will operate as specified.

- E. Prior to shop testing the SCADA system shall be fully functional as specified in Section 26 23 05. The switchgear control system shall be fully tested using the SCADA system as specified herein. The OIU shall be fully functional and the switchgear shall be fully tested using the OIU. All alarm and control functions specified shall be available and indicated on the OIU.
- F. At a minimum, perform the following operational tests:
1. Verify that the system performs the sequence of operations as specified.
 2. Verify that the equipment performs each task as specified.
 3. Verify all engine and generator protection functions for each GC.
 4. Verify all feeder protection functions for the FPR.
 5. Verify that the PLC starts and stops each generator based on the requirements of the demand table specified herein.
 6. Verify that each annunciation point operates correctly. For external alarms, simulate the alarm.
 7. Verify that all screens on the SCADA display correct data. Use an external computer to verify remote access for SCADA.
 8. Test each VFD. Impress a 4-20 mA signal and verify the output of the VFD. Bench test completed unit. Provide a 3-phase motor of the size indicated and verify that the motor operates based on the 4-20 mA input signal.
 9. Disconnect 120-volt AC control power in the master section to verify that the system continues to operate without interruption from the 24VDC source and that the server continues to operate from the UPS. Briefly turn off the 24VDC source and verify function of the battery buffer module.
- G. Feeder Breaker Testing. Perform functional tests to prove correct wiring and operation of equipment. The tests shall include but not be limited to the following:
1. Input 3-phase AC signal voltage to all external terminal blocks where potential transformer connections shall be made. Verify with a voltmeter and phase angle meter that the correct voltage is present at all points indicated.
 2. Input 3-phase AC signal current to all external terminal blocks where current transformer connections shall be made. Verify with an ammeter, current test plug, and phase angle meter, where possible, that the correct current is present at all points indicated. Currents through devices not provided with current test jacks may be verified with a clamp-on ammeter.
 3. Using the Schweitzer AcSELeator QuickSet software, verify the values input into the relay are the actual values displayed by the relay. Verify that the voltages and currents are in the correct phase relationship and that the phase rotation is correct. Make any corrections necessary.

4. Operate each control switch and selector switch in all positions to verify that all control circuits operate as shown on the schematic diagrams.
 5. Verify proper operation of all blocking, closing, and tripping contacts of the FPR.
 6. Simulate remote contacts and switches by jumpers at the appropriate external terminal blocks to verify proper circuit operation.
 7. Visually verify that all indicating lights operate properly.
- H. The switchgear equipment and circuit breakers shall receive the following tests:
1. Equipment.
 - a. Low frequency dielectric test.
 - b. Grounding of instrument cases.
 - c. Control wiring and device functional test.
 - d. Polarity verification.
 - e. Sequence test.
 - f. Low frequency withstand voltage test on major insulation components.
 - g. Low frequency withstand voltage test on secondary control wiring.
 2. Main Bus: Megger test at 1000 volts each bus to ground and phase-to-phase.
 3. Contactors:
 - a. Coil check test.
 - b. Clearance and mechanical adjustment.
 - c. Electrical and mechanical operation test.
 - d. Conductivity of current path test.
- I. Tests that are provided by the manufacturer of the equipment need not be duplicated. Provide documentation that the manufacturer's test was performed and passed.
- J. Perform multiple repetitions of individual operations as required by the Authority to adequately demonstrate satisfactory operation of all functions.
- K. Provide test reports documenting completion of shop testing prior to shipping.
- L. Include complete test reports in the Operation & Maintenance Manual documenting all shop tests performed.

Note 1: All work described under Paragraph 3.4, Field Testing, will be performed by the Electrical Contractor responsible for installation in the power plant under a separate contract. Field Testing is not part of the switchgear purchase scope and is provided here for reference only.

Note 2: The Fabricator shall provide support to the Electrical Contractor during field installation, testing, and commissioning as previously specified. Support shall include but not be limited to programming revisions, SCADA revisions, and training.

3.4 **FIELD TESTING**

- A. *Upon completion of field installation the Contractor shall fully test the switchgear.*
- B. *Prior to field testing the SCADA system shall be fully functional as specified in Section 26 23 05. The switchgear control system shall be fully tested using the SCADA system as specified herein. The OIU shall be fully functional and the switchgear shall be fully tested using the OIU. All alarm and control functions specified shall be available and indicated on the OIU.*
- C. *Test procedures shall conform to ASME, IEEE, and ANSI standards, and NEMA standard practices section on testing, as appropriate and applicable. The Contractor shall provide all required equipment and measuring and indicating devices required to perform the tests indicated. All devices shall be certified correct or correction data furnished for the device.*
- D. *Field Testing and Commissioning shall coincide with Substantial Completion. Provide written notice to the Authority in accordance with 01 77 00 Contract Closeout. The Authority reserves the right to witness all tests.*
- E. *Prior to performing tests verify that all field assembly is complete, all sections have been fastened to floor, all shipping splits and bus connections have been torqued to manufacturer's recommendations, and all interconnecting wiring has been connected and secured.*
- F. *Perform adequate tests prior to Substantial Completion to verify that the switchgear is fully functioning. At a minimum, provide the following operational tests:*
 - 1. *Verify that the system performs the sequence of operations as specified under Part 4.*
 - 2. *Verify all protective relay functions for the FPR and GC.*
 - 3. *Verify all engine and generator protection functions for each GC.*
 - 4. *Verify all feeder protection functions for the FPR.*
 - 5. *Verify that the PLC starts and stops each generator based on the demand table requirements specified under Part 4.*
 - 6. *Verify that each VFD operates properly.*
 - 7. *Verify that each annunciation point operates correctly. For external alarms, simulate the alarm.*

8. *Verify that all screens on the SCADA display correct data. Use an external computer to verify remote access for SCADA.*
 9. *Verify that all trending functions are operational and are being archived on the data storage server.*
 10. *Disconnect 120-volt AC control power in the master section to verify that the system continues to operate without interruption from the 24VDC source and that the server continues to operate from the UPS.*
- G. *Repeat tests during Substantial Completion as required by the Authority to adequately demonstrate satisfactory operation of all functions.*

3.5 PACKAGING

- A. Shipping splits shall be provided in the switchgear for ease of handling in the field. The switchgear shall be shipped in splits as indicated on the project design drawings or as required for field installation.
- B. The switchgear shipping splits shall be individually shrink wrapped, packed, crated and rigidly braced to protect from damage during shipment, handling and storage. Each section shall be crated so that it can be shipped upright or placed flat on the backside of the panel. The packaging shall be waterproof. Moisture absorbent packages shall be placed in each compartment to ensure that moisture does not condense inside the switchgear.
- C. All other included components (spare parts, loose items, etc.) shall be packaged individually in waterproof wrapping. Each individual component package shall then be packed in a box or crate, and each box/crate wrapped in waterproof wrapping to prevent corrosion to the components during extended periods of outside storage. All boxes or crates shall be palletized onto the minimum number of pallets, as required for the quantity and size of the boxes/crates.
- D. Suitable attachments shall be provided on the bottom of the shipping assemblies for lifting or moving the equipment to final location. Provisions shall not necessitate disassembly of the equipment. Instructions for lifting the switchgear shall be provided. Additionally, the weight and center of gravity shall be provided.
- E. Exterior of crating shall be clearly marked with the community name and the contents identification (e.g. "Community" Gen #2).
- F. Two copies of the packing slip identifying the quantity of pallets, the crates/boxes on each pallet, and the listing of component packages within each box/crate shall be provided to the Owner.

PART 4 - MONITORING, CONTROL, AND SEQUENCE OF OPERATION

4.1 ENGINE MONITORING

- A. The GC shall monitor temperatures, alarms and status of the following engine devices:
1. Monitor engine speed, jacket water temperature, lubricating oil pressure, and fuel flow rate from the engine ECU via J1939.
 2. Engine Runtime. Log and maintain engine runtime. Time shall be expressed in hours. Note that when the engine ECU is off, the SCADA shall continue to display the Engine Hours at the time the engine stopped.
 3. Hours until Engine Service. Using the engine runtime from the GC, the PLC will log and maintain hours until engine service required. Time shall be expressed in hours.
 4. Generator Lockout Switch. Connect key switch to GC Discrete Input 5.
 5. Oil Level Switch. Monitor status of engine-mounted oil level switch through GC Discrete Input 3 and 4. A normally open switch closes when the oil level drops below or rises above a pre-determined level.
 6. Exhaust Gas Temperature. Monitor exhaust temperature through GC Analog Input 1 via a 4-20mA signal converter. The exhaust gas temperature sensor is a 2-wire 100 ohm RTD.
 7. Air Filter Vacuum. Monitor air vacuum through GC Analog Input 2 via a 4-20mA signal converter. The air filter vacuum transmitter is 4-20mA, -408" H2O to 0" H2O range. Power supply for the signal converter shall be provided from the GC power supply.

4.2 AMBIENT AIR TEMPERATURE MONITORING

- A. The PLC shall monitor through RTD input module the following air temperatures.
1. Outside air temperature.
 2. Inside air temperature.
 3. VFD section temperature(s).

4.3 FUEL AND OIL SYSTEM MONITORING

- A. The PLC shall monitor and provide the following:
1. Plant Total Fuel Consumption and Last Day Tank Fill Cycle Quantity. The PLC shall calculate the total plant fuel consumption and the last day tank fill cycle quantity from the day tank supply meter. Monitor daytank meter pulser through digital input module. The day tank meter pulser provides one pulse per each gallon of fuel.
 2. Plant Fuel Efficiency. The PLC shall calculate the overall plant fuel efficiency (kWh/gallon). At the end of each day tank fill cycle, divide the total kWh generated since the end of the last fill cycle (from bus power

meter) by the gallons of fuel pumped into the day tank during the latest fill cycle.

3. Low Fuel Level Alarm. Monitor daytank low level switch status through digital input module. A normally closed contact on the day tank control panel will open when the fuel level in the day tank drops below a preset level.
4. Generator Fuel Consumption. The PLC shall read the instantaneous fuel flow rate (gallons per hour) and the total fuel consumption (gallons) from the engine ECU via J1939.
5. Using remote I/O monitor status of the day tank including:
 - a. Fuel Filter Water Indication
 - b. Day Tank Pump P-DF1 Run.
 - c. Day Tank Control Power.
 - d. Day Tank Low Level Alarm.
 - e. Day Tank Overfill Alarm.
 - f. Day Tank Pump P-DF1 Time Out Alarm.
 - g. Remote Actuator Valve Open.
6. Using remote I/O monitor status of the used oil blender including:
 - a. Blender Pump P-DF2 Run.
 - b. Blender Pump P-UO2 Run.
 - c. Blender Control Power.
 - d. Blender Filter #1 Plugged.
 - e. Blender Filter #2 Plugged.
 - f. Blender Hopper Low Oil Level.
7. Using the EVO 200 level monitoring system monitor the level and temperature of the fluid in the day tank and the used oil hopper. Where specifically indicated, monitor the level in the intermediate fuel tank.
8. Plant Total Used Oil Blending System Consumption, Last Oil Blend Cycle Quantity and Overall Blended Oil Percentage. The PLC shall calculate the total used-oil use, the last blend cycle quantity, and the overall percentage of blended oil in the fuel supply. The data for these calculations comes from the day tank meter pulser (at one pulse per each gallon of fuel) and the EVO 200 level monitor.

4.4 COOLING SYSTEM MONITORING

- A. The PLC shall monitor the following:

1. Low Coolant Alarm. Monitor low coolant level switch status through digital input module. A normally closed switch in the coolant piping will open when the coolant drops below a preset level.
2. Engine Coolant Return Temperature. Monitor engine coolant return temperature through analog input module via a 4-20 mA, 20°F to 240°F range temperature transmitter. Power supply for the transmitter shall be provided from the switchgear 24VDC power supply.
3. Coolant Level Sensor. Monitor coolant level through analog input module via a 4-20 mA, 0% to 100% range signal conditioner. Power supply for the signal conditioner shall be provided from the switchgear 24VDC power supply.

4.5 HEAT RECOVERY SYSTEM MONITORING

- A. The PLC shall monitor through analog input module the following:
1. Heat Recovery Supply Temperature. Monitor heat recovery supply temperature via a 4-20 mA, 20°F to 240°F range temperature transmitter. Power supply for the transmitter shall be provided from the switchgear 24VDC power supply.
 2. Heat Recovery Return Temperature. Monitor heat recovery return temperature via a 4-20 mA, 20°F to 240°F range temperature transmitter. Power supply for the transmitter shall be provided from the switchgear 24VDC power supply.
 3. Heat Recovery Pressure. Monitor heat recovery fluid pressure via a 4-20 mA, 0 to 60 PSIG range pressure transmitter. Power supply for the transmitter shall be provided from the switchgear 24VDC power supply.
 4. Heat Recovery Flow Rate. Monitor heat recovery fluid flow rate via a 4-20 mA, 0 to 100 GPM range flow meter. Power supply shall be provided from the switchgear 24VDC power supply.

4.6 OIU DISPLAY

The OIU shall provide the operator local access to the demand system setup parameters and shall display all screens required for system monitoring. The OIU shall communicate with the PLC via Ethernet/IP for tag information. The OIU programming and development of all display screens shall be provided by the Fabricator, see SCADA specification 26 23 05. The Fabricator shall program the following functions and display the following data. All multiplication factors or other proportional scaling of the raw data shall be provided by the Fabricator so the data provided will not need to be modified.

- A. Demand Control – Generator kW rating (overload level), raise level set point, raise level time duration, lower level set point, lower level time duration.
- B. Generator Control – Amount of time each generator will run off-line before it is shut down (cooldown duration).
- C. Engine/Generator Data:
1. Alarms – All engine/generator alarm conditions.

2. Status of the engine (Off, Auto, Manual)
 3. Status of the breaker (open or closed).
 4. Phases A, B, and C voltage, current, and power factor.
 5. Generator Frequency (Hz).
 6. Engine Speed (RPM).
 7. Engine Run Time (hours).
 8. Hours until Engine Service (hours).
 9. Engine Water Jacket Temperature (°F).
 10. Engine Exhaust Temperature (°F).
 11. Engine Oil Pressure (PSI).
 12. Engine Air Cleaner Vacuum (in-H₂O).
 13. Engine Fuel Flow Rate (GPH).
 14. Fuel Efficiency (kWh/Gal).
 15. Total kWh Generated.
 16. Lead Engine - where engines are the same capacity.
- D. Bus/Station Service Power Data:
1. Bus Phases A, B, and C voltage and current.
 2. Bus frequency, kVAR, kW and power factor, total kWh and peak demand.
 3. Station service Phases A, B, and C current.
 4. Station service kW and total kWh.
 5. Trip indication for station service breaker.
- E. Feeder Data:
1. Position indication for each feeder breaker
 2. Trip indication for each feeder breaker.
 3. Calculate the feeder kW and kWh by subtracting the station service readings from the bus meter readings.
- F. EtherNet/IP Point I/O Status
- G. Fuel/Oil System Data
1. Fuel level and temperature in day tank, used oil hopper, and intermediate tank (where specifically indicated).
 2. Plant total fuel use.
 3. Plant total fuel efficiency.
 4. Plant previous 30 minute fuel efficiency.
 5. Day tank last fill quantity.

6. Fuel filter water indication.
 7. Day tank pump P-DF1 run.
 8. Day tank control power.
 9. Day tank low level alarm.
 10. Day tank overfill alarm.
 11. Day tank pump P-DF1 time out alarm.
 12. Remote actuator valve open.
 13. Last oil blend quantity.
 14. Overall oil blend percentage.
 15. Plant total used oil blended.
 16. Blender pump P-DF2 run.
 17. Blender pump P-UO2 run.
 18. Blender Control Power.
 19. Blender filter #1 plugged.
 20. Blender filter #2 plugged.
 21. Blender used oil hopper low alarm.
- H. Ambient Temperature Data:
1. Outside Air Temperature.
 2. Inside Air Temperature.
 3. VFD Section Temperature(s).
- I. Engine Coolant Data:
1. Low coolant level alarm.
 2. Coolant return temperature.
 3. Coolant level.
- J. VFD Data – All data available from each variable frequency drive, quantity as indicated on the communication diagram of the project design drawings.
1. Radiator coolant temperature.
 2. VFD breaker open.
 3. VFD frequency.
 4. VFD status (VFD, Off, Bypass, Running, Fault).
- K. Heat Recovery System Data:
1. Supply Temperature.
 2. Supply Temperature Signal Lost.

3. Return Temperature.
4. Return Temperature Signal Lost.
5. System Pressure.
6. Flow Rate.
7. No Load Warning.
8. Loss of Pressure.
9. Loss of Flow.
10. Recovered Heat Output.
11. Total Recovered Heat Delivered.

4.7 GENERAL CONTROL SPECIFICATIONS

- A. The switchgear shall automatically and manually connect and parallel all generators to the switchgear main bus.
- B. The PLC shall control the automatic load demand system and overall sequencing, starting, and stopping of the engine generators. The SCADA on the OIU shall provide operator access to the demand system and shall display the current demand system status.
- C. The GC shall control all functions and features of the generator under both automatic and manual control. The GC shall start, stop, synchronize, and provide load sharing of the generator. All GC's shall communicate via CANbus for load sharing. If the communications bus is disabled, each GC shall be fully capable of operating the individual generator without the aid of the PLC.
- D. The Fabricator shall review all project design drawings and information provided and shall incorporate all required engine and generator safety functions into the GC.

4.8 GENERATION SEQUENCE OF OPERATION.

- A. A complete and successfully operating system shall be provided for starting, stopping, and paralleling, both automatically and manually, all engine generators. The following paragraphs describe the basic functional requirements of the system. The Fabricator shall be responsible for the detailed design to provide a safe and satisfactorily functioning system.
- B. The PLC shall monitor the system load and status and shall control automatic start and stop of each unit. Time delays shall be incorporated in the PLC that shall be adjustable through the OIU. Use relays in conjunction with PLC logic for automatic start/stop. Failure of the automatic control system shall not prevent the manual operation of the system to start, stop, or synchronize any one, or all, of the generating units.
- C. The GC shall be configured according to the parameters indicated in Attachment A, Genset Controller Settings Table, which is appended at the end of this Section.

- D. The GC shall control engine speed, voltage compensation, synchronization, and generator breaker operation.
1. The GC shall perform all engine and generator safety functions. Provide annunciation through the PLC via Point I/O blocks.
 2. The GC shall perform the cranking and disconnecting of the starter.
 3. The GC shall turn on the run signal to the ECU then have a 5 second delay before cranking the starter to ensure fuel is up to pressure. During the delay the GC shall display a banner indicating pre-start mode.
 4. The GC shall make up to 4 attempts to start an engine with a pre-set cranking time of 10 seconds and a 10 second pause between each attempt. If the engine does not start after the fourth time, the OVERCRANK and ENGINE ALARM lamp will illuminate and a FAIL TO START message will appear on the monitoring screen.
 5. The GC shall control the engine speed using 0.5-4.5 VDC signal to the engine ECU.
 6. The GC shall control the voltage regulator through the voltage regulator auxiliary voltage bias input.
 7. Generator Lockout Switch. When in the OFF position the switch shall disable the GC and prevent engine starting.
- E. Upon activation of the dead bus relay the feeder breaker shall open. This function shall be independent of the PLC and shall operate in all modes.
- F. Automatic Operating Conditions.
1. With the System Mode Switch in the "AUTO" position and each GC in "AUTO" mode, the following sequences of operation shall be performed:
 - a. Dead-Bus Startup: All available generators shall start and come up to rated speed. The generators shall be started sequentially in order of generator number with a 15 second delay between each start signal. The first unit to stabilize will close to the dead bus. The remaining units shall auto-synchronize to that unit and close to the bus in sequence. After 15 second delay after the last generator comes on line, the PLC shall close the feeder breaker and energize the feeder. On systems with two feeder breakers the PLC shall close feeder breaker #1 and then after an additional time delay of 15 seconds, the PLC shall close feeder breaker #2. If available, a minimum of two units shall be running and synchronized prior to energizing the feeder. If only one generator is available for operation, the PLC shall use that unit to energize the feeder.
 - b. With all available units operating and all GC's in "AUTO" mode, the PLC shall monitor the bus load and determine which unit best fits the demand load. The PLC shall signal the GC to unload and shut down any unit not needed to meet the load.

- c. When the load exceeds a preset percentage of the prime power rating of a unit, the PLC shall signal the GC to automatically start, synchronize, and connect to the bus another unit. Predetermined demand level set points in the PLC shall determine which unit should be placed online. If that unit is not available, the PLC shall automatically switch to another unit. The PLC shall continue to monitor load and signal the appropriate GC to start, synchronize, unload, and stop as required, to match the appropriate unit to the load.
- d. Provide lead/lag control for multiple generators of the same capacity so the operator can manually select one generator to run preferentially. When a second generator is required or the lead generator faults, the PLC shall select the next unit in numerical order (2--3--4--1).
- e. When any GC is not in "AUTO" mode, the PLC shall skip that unit and switch to the next available unit. Any time a unit's GC is switched from "STOP" or "MAN" to "AUTO" mode, the PLC shall compare the unit with the operating unit and load to determine which unit is more appropriate for the load. If the new unit is more appropriate, the PLC shall send a command signal to the GC to start, synchronize, and connect the unit to the bus and unload and shut down the other.
- f. When one unit is operating and is dropped from the bus, for any reason, the PLC shall signal all GC's to automatically start all remaining available units and perform a dead bus start up sequence as previously specified. After the bus is stabilized, the PLC shall resume normal demand level control operation and signal the GC's to shut down units not required to carry the load.
- g. When two units are operating and one of the units is dropped from the bus for any reason, the PLC shall check the raise level and overload level of the unit operating. When the system demand exceeds the raise level of the operating unit, the PLC shall signal the GC to start the next unit and place it in service after the raise level time delay times out. When the system demand exceeds the overload level of the operating unit, the PLC shall immediately signal the GC to start the next unit available under the automatic demand system and place it in service within 10 seconds.
- h. The GC shall provide a programmable cool down period for each unit prior to engine shut down. Each unit shall operate at rated speed for 3 minutes, and then automatically stop the engine.
- i. When the GC of an operating unit is switched to "MAN" mode, the PLC shall signal the GC to start another unit, as specified above. The unit placed in "MAN" mode will continue to run until the GC is switched to "STOP" or placed in "AUTO".

- j. When the GC of an operating unit is switched to “STOP” mode, the GC will check to see if any other generators are online. If there is another unit on-line, the GC will shed the load to the other unit, open the generator breaker, and shut off the engine after a cool-down period. If there is no other unit on-line, the generator breaker will open and the engine will shut off after a cool-down period.
 - k. Upon normal shut down of a unit, all parameters shall be automatically reset to allow the unit to be operated again, either manually or automatically, without further reset action.
- 2. When the System Mode Switch is switched from the “AUTO” position to the “MAN” position while units are operating in automatic mode, the system shall continue to operate in the present state. If the Mode Switch is moved back to the “AUTO” position, the PLC shall revert to operation in the automatic demand mode.
- 3. Demand Control: The automatic Demand Control System shall provide 2 levels of starting control and 1 level of stopping control.

The 2nd level of starting control is considered the “overload” level and it shall be equal to the generator prime power rating. When the load equals or exceeds the “overload” level the system shall immediately go to the next higher demand level.

The 1st level of starting control is considered the “raise” level and it shall normally be equal to 90% of the generator prime power rating. When the load equals or exceeds the “raise” level for 20 seconds, adjustable, the system shall go to the next higher demand level.

The stopping control is considered the “lower” level and it shall normally be equal to 80% of the generator prime power rating. When the load is less than the “lower” level for 120 seconds, adjustable, the system shall go to the next lower demand level.

The Demand Control System shall have multiple demand levels. The highest demand level will command all units to start and go on-line.

See project design drawings for demand control settings.
- G. Manual Operating Condition. When the System Mode Switch is in the "MAN" position each generator GC shall control the respective generator in isochronous mode. The GC must be placed in MAN mode to start, stop, and control the generator. All functions shall be manually executed through the GC. If multiple generators are placed online the GC's shall proportionally share load.
- H. Engine and Generation Alarm Conditions and Sequences. Note that these apply to both Auto and Manual operation.
 - 1. Provide the following types of alarm sequences for each condition listed below:
 - a. Type 1 (Engine Alarm Soft Shutdown):

Upon alarm condition bring another generator on line, unload the first generator, open the generator breaker, run engine through a cool down cycle, shut down engine, and illuminate “Alarm/Lockout” light and associated alarm annunciation light. Alarm light shall remain illuminated until the problem is corrected and the GC is manually reset. Note that this a Class B Easygen alarm with PLC assist to first start another generator and then take the first offline.

b. Type 2 (Engine Alarm Hard Shutdown):

Upon alarm, immediately open the generator breaker and shut down without going through a cool down cycle. Illuminate “Alarm/Lockout” light and associated alarm annunciation light. Unit shall be locked out and alarm light shall remain illuminated until the problem is corrected and the GC is manually reset. Note that this a Class F Easygen alarm.

c. Type 3 (Generation Alarm):

Upon alarm, immediately open the generator breaker, run engine through a cool down cycle, shut down engine, and illuminate “Alarm/Lockout” light and associated alarm annunciation light. Unit shall be locked out and alarm light shall remain illuminated until the problem is corrected and the GC is manually reset. Note that this a Class D Easygen alarm.

2. For the following engine/generator alarm conditions perform the sequence indicated and illuminate the associated alarm light. See Attachment A, Genset Controller Settings Table, for specific alarm and shut down setpoints and time delays.

- a. Low Oil Pressure - Provide a Type 1 soft shutdown when the oil pressure drops to the Alarm level and stays below that level for 5 seconds, or if the pressure transducer signal is lost. Provide a Type 2 hard shutdown when the oil pressure drops to the Shut Down level and stays below that level for 5 seconds.
- b. Oil Level - Provide a Type 1 soft shutdown when the oil level switch closes.
- c. High Coolant Temperature - Provide a Type 1 soft shutdown when the jacket water temperature reaches the Alarm level and stays above that level for 30 seconds or if the temperature transducer signal is lost. Provide a Type 2 hard shutdown when the jacket water temperature reaches the Shut Down level and stays above that level for 30 seconds.
- d. Over Speed - Provide a Type 2 hard shutdown when the engine speed reaches the Shut Down level.
- e. Over Crank – Lock out engine if a unit fails to start when the over crank time delay has expired.

- f. Running Timeout - Shut down the engine and lock it out if the engine runs without being placed online for 5 minutes, adjustable.
 - g. Battery Charger Failure – Illuminate the appropriate alarm light when an alarm is received from the battery charger. Note this alarm is for indication only and not shutdown.
 - h. Air Filter Plugged - Provide a Type 1 soft shutdown when the vacuum on the air filter reaches the Alarm level and stays above that level for 60 seconds or if the vacuum signal is lost. Provide a Type 2 shut down when the vacuum on the air filter reaches the Shut Down level and stays above that level for 30 seconds.
 - i. High Exhaust Temperature – Illuminate the associated alarm light when the exhaust temperature reaches the Alarm level and stays above that level for 30 seconds or if the temperature signal is lost. Note this alarm is for indication only and not shutdown.
 - j. Fail to Synchronize - Provide a Type 3 shutdown if a unit fails to synchronize after the preset time delay.
 - k. Over Current - Provide a Type 3 shutdown on operation of an overcurrent element. See the project design drawings for the trip setpoint for each generator.
 - l. Under Voltage - Provide a Type 3 shutdown when the voltage reaches the Shut Down level and stays below that level for 5 seconds.
 - m. Over Voltage - Provide a Type 3 shutdown when the voltage reaches the Shut Down level and stays above that level for 5 seconds.
 - n. Under Frequency - Provide a Type 3 shutdown when the frequency reaches the Shut Down level and stays below that level for 5 seconds.
 - o. Over Frequency - Provide a Type 3 shutdown when the frequency reaches the Shut Down level and stays above that level for 5 seconds.
 - p. Reverse Power - Provide a Type 3 shutdown when the reverse power reaches the Shut Down level and stays above that level for 5 seconds.
3. For the following system alarm conditions perform the sequence indicated and illuminate the associated alarm light:
- a. Fire Alarm - Upon receipt of a contact closure from the fire suppression system, all engines shall be shut down immediately without going through a cool down sequence. The system shall remain in a lockout condition and no units shall be started either manually or automatically until the alarm is cleared.

- b. Emergency Stop - Upon receipt of a contact closure from the Emergency Stop Pushbutton, all engines shall be shut down immediately without going through a cool down sequence. The system shall remain in a lockout condition and no units shall be started either manually or automatically until the alarm is cleared.
 - c. Low Coolant Level – Opening of the low coolant alarm contact on the system low coolant level switch, all engines shall be shut down immediately without going through a cool down sequence. The system shall remain in a lockout condition and no units shall be started either manually or automatically until the alarm is cleared.
 - d. Low Fuel Level - Opening of the low fuel alarm contact on the day tank control panel (separate external panel) indicates a low fuel level condition. The low fuel level indication shall start a time delay relay, 2 hours, adjustable, and illuminate the alarm lamp. If the fuel level has not been corrected by the end of the timed interval all engines shall go through a Type 1 soft shutdown and the alarm lamp shall remain illuminated. The manual alarm reset button on the front of the switchgear master section will reset the timer relay for another interval and place the engines back in service if timed out. The reset function shall work any time during or after expiration of the timed interval.
 - e. PLC/ Point I/O Failure - Upon failure of the PLC or the Point I/O network, the alarm light shall remain illuminated until the system is back in acceptable service.
 - f. System Not In Auto – When the System Mode Switch is changed from Auto to Manual the alarm lamp shall illuminate. The alarm lamp shall remain illuminated until the Mode Switch is switched back to Auto.
 - g. Feeder Breaker Trip – Upon over current, the feeder breaker shall immediately trip and the alarm lamp shall illuminate. The generator shall continue to operate at rated speed.
- I. Engine Service Alarm Conditions and Sequences. Note that this applies to Auto operation.
- 1. When an engine exceeds 300 service hours perform the sequence indicated below:
 - a. The Engine “Alarm/Lockout” annunciator is illuminated.
 - b. The “Service Engine” annunciator is illuminated
 - c. Demand control starts the next available engine, syncs it to the bus, closes the breaker, and transfers load.
 - d. A Type 1 shutdown is performed on the engine with service overdue.

- e. Upon completion of the required engine service the operator shall press and hold the Service Hours Reset pushbutton for 10 seconds to reset the service interval to 300 hours. The operator shall then press the Alarm Reset pushbutton to clear the engine alarm. Once the service is complete and the alarm is cleared the operator shall put the engine back into Auto mode.
- f. Note: If the required engine service is performed manually prior to the Engine Service Alarm condition, the operator shall follow the procedure above without alarm condition in order to reset the service interval to 300 hours and place the engine back in service.

4.9 FEEDER BREAKER SEQUENCE OF OPERATION

- A. Automatic Operation - When the System Mode Switch is in the "AUTO" position the feeder breaker shall operate under control of the PLC. The feeder breaker can be opened at any time by rotating the feeder control knob to the OPEN position. The PLC shall then perform a dead bus start sequence (start all available generators) and re-close the feeder breaker after the pre-set time delay.
- B. Manual Operation - When the System Mode Switch is in the "MAN ISOCH" position and the bus is energized, the feeder breaker will operate under manual control. The feeder breaker shall close when the feeder control knob is rotated to the CLOSE position and open when the feeder control knob is rotated to the OPEN position.
- C. The Feeder Protection Relay (FPR) shall provide protection for the feeder breaker in both Automatic and Manual modes. The FPR settings shall be set to the values on the project design drawings and shall be adjustable.

4.10 VFD SEQUENCE OF OPERATION

- A. General VFD Sequence of Operation. Each variable frequency drive shall operate as follows:
 - 1. When the VFD main circuit breaker is closed and the selector switch is in either the "VFD" or "BYPASS" position, power shall be provided to all control devices. Time delay shall be incorporated into the fault alarm such that there is no alarm due to initial powering up of the VFD.
 - 2. When the VFD main circuit breaker is open, the red "VFD Breaker Open" lamp shall illuminate and remote indication shall be provided to the PLC.
 - 3. When the 3-position selector switch is in the "OFF" position, the motor will not operate and power to all control devices will be off.
 - 4. When the 3-position selector switch is in the "Bypass" position, the motor shall operate at full speed and the "Bypass Mode" light shall be on. The VFD will not be in service and the contactor will be open. Provide remote indication that the VFD is in bypass mode from an auxiliary contact as indicated.
 - 5. When the 3-position selector switch is in the "VFD" position, the motor shall operate under control of the VFD and the "VFD Mode" light shall be

- on. Upon receipt of a run signal the contactor shall close, the motor shall operate, and the “VFD Running” light shall be on.
6. Upon a fault of the VFD the red “VFD Fault” lamp shall illuminate and remote indication shall be provided to the PLC. Placing the selector switch in the “OFF” position shall clear the fault alarm indication.
 7. Upon activation of the thermal overload, the VFD main circuit breaker shall trip, the red “VFD Breaker Open” lamp shall illuminate and remote indication shall be provided to the PLC.
 8. Engine Coolant Return High Temperature Alarm. When the engine coolant return temperature rises above 190°F for a minimum of 2 minutes, the “HIGH COOLANT RETURN TEMPERATURE” lamp shall illuminate. Lamp shall remain on until master reset button is pressed
- B. Radiator Sequence of Operation. Each variable frequency drive for glycol coolant radiators shall operate as follows:
1. The remote temperature sensor will sense Coolant Return Temperature and send a 4-20mA signal to the VFD where 20°F equals 4 mA and 240°F equals 20 mA. The operating temperature setpoints shall be adjustable through the OIU and scaled to display in °F.
 2. When the Coolant Return Temperature reaches the PID Reference Temperature setpoint the motor will start at minimum speed and ramp up to the required speed.
 3. Using its internal PID control, the VFD will modulate the fan speed as required to maintain Coolant Return Temperature at the PID Reference Temperature setpoint. As the Coolant Return Temperature rises, the VFD will increase the speed of the fan motor up to 100%. Once the fan reaches the Minimum Speed, the VFD will maintain that speed until the Low Speed Time Out expires.
 4. When the Low Speed Time Out expires the motor will stop. The motor will remain off until the Coolant Return Temperature rises to the Wake Up Temperature setpoint.
 5. Configure the OIU to display the fan speed in percentage and the PID Reference Temperature setpoint and Coolant Return Temperature in °F.
 6. The operating settings shall be set to the values on the project design drawings and shall be adjustable.

4.11 HEAT RECOVERY SEQUENCE OF OPERATION

- A. The PLC shall perform the following functions. Note that all heat recovery alarms shall be tied to the dead bus signal to prevent alarm indication when the power system is off-line:
1. Heat Recovery No Load Warning. When the heat recovery return temperature is greater than the heat recovery supply temperature for a minimum of 1 hour, the “NO LOAD ON HEAT RECOVERY” lamp shall

illuminate. When the heat recovery supply temperature is a minimum of 1°F greater than the heat recovery return temperature the lamp shall turn off.

2. Signal Loss. If either the supply temperature or the return temperature signal is lost, the system shall provide the following message on the OIU “HEAT RECOVERY SUPPLY TEMPERATURE SIGNAL LOST” or “HEAT RECOVERY RETURN TEMPERATURE SIGNAL LOST”.
3. Heat Recovery Loss of Pressure Alarm. When the heat recovery system pressure drops below 15 PSIG for a minimum of 15 minutes, the “HEAT RECOVERY LOSS OF PRESSURE” lamp shall illuminate. When the pressure rises above 18 PSIG the lamp shall turn off.
4. Heat Recovery Loss of Flow Alarm. When the heat recovery system flow rate drops below 10 GPM for a minimum of 15 minutes, the “HEAT RECOVERY LOSS OF FLOW” lamp shall illuminate. When the flow rate rises above 15 GPM the lamp shall turn off.
5. Recovered Heat Output. The PLC shall calculate the instantaneous rate of energy delivered based on the supply temperature, return temperature, and flow rate. A specific heat of 450 BTUH/GPM-F shall be used for the fluid.
6. Total Recovered Heat Delivered. The PLC shall calculate the total energy delivered in units of 100,000 BTU with no decimal places.
7. History. The PLC shall maintain a running total of energy delivered.

SEE ATTACHMENT A, GENSET CONTROLLER SETTINGS TABLE

SEE ATTACHMENT B, PROJECT DESIGN DRAWINGS

Alarm Classes	Type 1 = Class B (Warning) Type 2 = Class F (Open GCB & Immediate Shutdown) Type 3 = Class D (open GCB & cool down)
----------------------	---

NOTES:

Engine Speed Source

Generator/Engine

Custom Program or Turn off button
Custom Program or Turn off button

5508/5510/5511: use default settings for John Deere

powers up ECM 5 seconds before cranking to prime fuel system

* Monitor Wire Break/Signal Loss - High/Low

sender value 4-20mA

sender value 4-20mA

Not Used This Project - No Charge Air Coolers

JD:Type=V; Min/Max=0.5/4.5; EPG: +/- 3V

Basler DECS Bias: +/- 10V, CAT CDVR & Marathon DVR2000E Bias: +/- 3V

Home Screen data: Engine	RPM, Engine Hours, Oil Pressure, Battery Voltage, Coolant Temperature
: Generator	Volts, Power (kW), Freq, PF, AMPS - L1, L2, L3

Custom Screen 1	
Custom Screen 2	

Configure frequency control	freq ctl init state	proportional gain	integral gain
Frequency Control Initial State	0.5	1	1

Configure general engine	Time	Ign delay	Vlv delay	S/S mode	Pre-mode
Preglow	5	5	5	Diesel	ALWAYS

Configure Analog Inputs	Input	Type	Value	Sender	Self Ackn	Unit	Class*
Exhaust Temp	1	Linear	70-1400	0-20mA	No	F	B
Air Filter	2	Linear	-408 - 0	0-20mA	No	IWC	B
Intake Air Temp	3	Linear	20-240	0-20mA	No	F	B

Configure Analog OUTputs	Type	Filter	Src Min	Src Max	Min Lvl	Max Lvl	PWM lvl
Speed Bias	Out 1	V	Off	0	100	0.5	4.5
Voltage Bias	Out 2	V	Off	0	100	-10	10

Configure Discrete Inputs	Input	Delay	Contact	Class	Enabled	Self Ackn
E-Stop	1	0.2	N.O.	F	Always	No
Start in Auto	2	0.5	N.O.	Control	Always	No
Oil Level Switch (Alarm)	3	5	N.O.	B	Always	No
Oil Level Switch (SD)	4	100	N.O.	F	Always	No
Stop Mode Lockout Switch	5	0.5	N.O.	F	Always	Yes
Idle Mode / Spare / VFD Fault	6	0.5	N.O.	Control	Always	No
MCB Open Reply	7	0.5	N.O.	Control	Always	No
GCB Open Reply	8					
Remote Acknowledge	9	0.2	N.O.	Control	Always	No
Spare or Baseload	10	0.2	N.O.	Control	Always	No
PLC E-Stop / Master Shutdown	11	0.2	N.O.	F	Always	No
Run w/o Load or spare	12	0.2	N.O.	Control	Always	No

Spare

when stop switch set to RUN, easygen remains in STOP Mode

Class: Idle Mode = Control, VFD Fault = Class B

D17 Jumpered for Islanded System

non configurable

Flexible Limit 11 used for Running Timeout

DI11 triggers EasyGen "Master Shutdown" alarm, indicates from Master Section

DI12 keeps gen from closing to bus when bus is dead and SMS is not in auto

refer to easygen terminal diagram for function

typically used when door-mounted pushbuttons provide easygen input

Verify with Operator if 250hr / 300hr or 500 hr Oil Change Interval

15320 Select ext terminals

verify Bus PT is 2.4 or 4:1 (2.4=200V, 4=120V)

Set 1752 and 1758 (kW/kVar) based on Generator Prime Rating

1754 (rated current) set based on Gen Conductor Ampacity

1800: Confirm PT ratio 2.4:1; 1806: Primary Rated Current = CT ratio

Set rated kvar, kW & rated current = sum of Gen Prime Ratings

1803: Confirm PT ratio 2.4:1; 1807: Mains Rated Current = CT ratio

Configure Discr Outputs (relays)	Relays Use Program Logic
---	--------------------------

Configure external discrete Inputs	Delay	Contact	Class	Enabled	Self Ackn
---	--------------	----------------	--------------	----------------	------------------

Configure Ctrs/Service Reset value	250 or 300 or 500
---	-------------------

Configure Interfaces/CANopen	used with IKDs
-------------------------------------	----------------

Configure Measurement	Value	Unit	Scale	Offset	Limit
Busbar / configure transformer	480V	10%	200V		480V
Engine	1800 rpm				
Generator	See Notes		L1 L2 L3		480V
Configure transformer	200V	480V	See Notes		480V
Mains	See Notes		Phase L1		480V
Configure transformer	200V	480V	See Notes		

Configure Monitoring	Monitor	Class	Atmp/Ack	Time	Limit	Enabled
Configure GCB	ON	B	5 tries	2s	--	--
Configure MCB	OFF					
Configure Synch GCB	ON	D	No	60s	--	--
Engine/Overspeed Level 2	ON	F	No	0.5s	1900rpm	Always
Engine/Speed Detection	ON	E	No	1s	--	Eng.mon
Engine/Start/Stop/SD malfunction	ON	F	No	30s	--	--
Engine/Start/Stop/Start Fail	ON	F	No	--	--	--
Engine/Start/Stop/Unintended stop	ON	F	No	--	--	--

spare, Not Used - easygen does not shutdown engine on high ex temp

Not Used This Project - No Charge Air Coolers

Not Used This Project - No Charge Air Coolers

UNITS are kPa

UNITS are kPa

UNITS are C

UNITS are C

Config Monitoring Flexible Limits	Input	Monitor	Class	Self Ackn	Enabled	Monitor	Limit	Delay
Exhaust Temp SD	1	OFF	F	No	Always	Overrun	950F	30
Exhaust Temp Alarm	2	ON	A	No	Always	Overrun	900F / 482C	30
Air Filter Restriction SD	3	ON	F	No	Always	Underrun	-20" WC/-1.47" Hg	30
Air Filter Restriction Alarm	4	ON	B	No	Always	Underrun	-15" WC/-1.10" Hg	60
High Intake Air SD (CAC)	5	ON	F	No	87.70 LM:Eng.mon	Overrun	170F	30
High Intake Air Alarm (CAC)	6	ON	B	No	87.70 LM:Eng.mon	Overrun	165F	30
Low Oil Pressure SD	7	ON	F	No	87.70 LM:Eng.mon	Underrun	10PSI/69kPa	5
Low Oil Pressure Alarm	8	ON	B	No	87.70 LM:Eng.mon	Underrun	14.5PSI/100kPa	5
High Coolant Temp SD	9	ON	F	No	Always	Overrun	215F / 102C	30
High Coolant Temp Alarm	10	ON	B	No	Always	Overrun	210F / 99C	30
Running Timeout	11	ON	F	No	Always	Overrun	300s	1

setpoints may be either Metric or ANSI units

Config Monitoring Generator	Monitor	Class	Self Ackn	Enabled	Limit	Delay (sec)	Rest / Hyst
Current/OC Level 1	--	ON	D	No	100%	3	No
Current/OC Level 2	--	ON	D	No	120%	1	No
Current/OC Level 3	--	ON	D	No	250%	0.4	No
Frequency/OF Level 2	--	ON	D	No	103%	5	--
Frequency/UF Level 2	--	ON	D	No	Eng.mon	97%	--
Operating Ranges	--	OFF	--	--	--	--	--
Other Monitoring/Phase rotation	--	ON	F	No	Always	--	CW
Other Monitoring/Power factor	--	OFF	--	--	--	--	--
Power/Load Share	--	OFF	--	--	--	--	--
Power/Overload	--	OFF	--	--	--	--	--
Power/Power Mismatch	--	ON	B	No	5%	30	--
Power/Gen Unloading mismatch	--	ON	B	No	5%	60	--
Power/Rev / Reverse power level 2	--	ON	D	No	Always	-10%	--
Power/Unbal Load	--	OFF	--	--	--	--	--
Power/Volt/OV Level 2	--	ON	D	No	Always	110%	--
Power/Volt/UV Level 2	--	ON	D	No	Eng.mon	90%	--

used when genset is in Baseload

60s min delay, 180s max delay

Mains	OFF??
-------	-------

Miscellaneous/Free Alarms	Alarm	Class	Self Ackn	Enabled	Monitor	Delay
Oil Level AL	1	B	No	Always	Disc Inp 3	5
Oil Level SD	2	F	No	Always	Disc Inp 3	100

input from DI3

input from DI3

Miscellaneous/Interfaces	Monitor	Class	Self Ackn	Enabled	Delay
CAN Interface 2	--	ON	B	Yes	0.2
J1939 Amber Alarm	--	OFF	A	No	2
J1939 DM1 alarms	--	OFF	--	Yes	--
J1939 Interface (Device 1-3)	--	OFF	--	--	--
J1939 Red Alarm	--	OFF	F	No	2

16187 CAN2 Monitoring

15120 J1939 Monitoring

15156 J1939 Monitoring

1919 Monitoring

15115 Monitoring

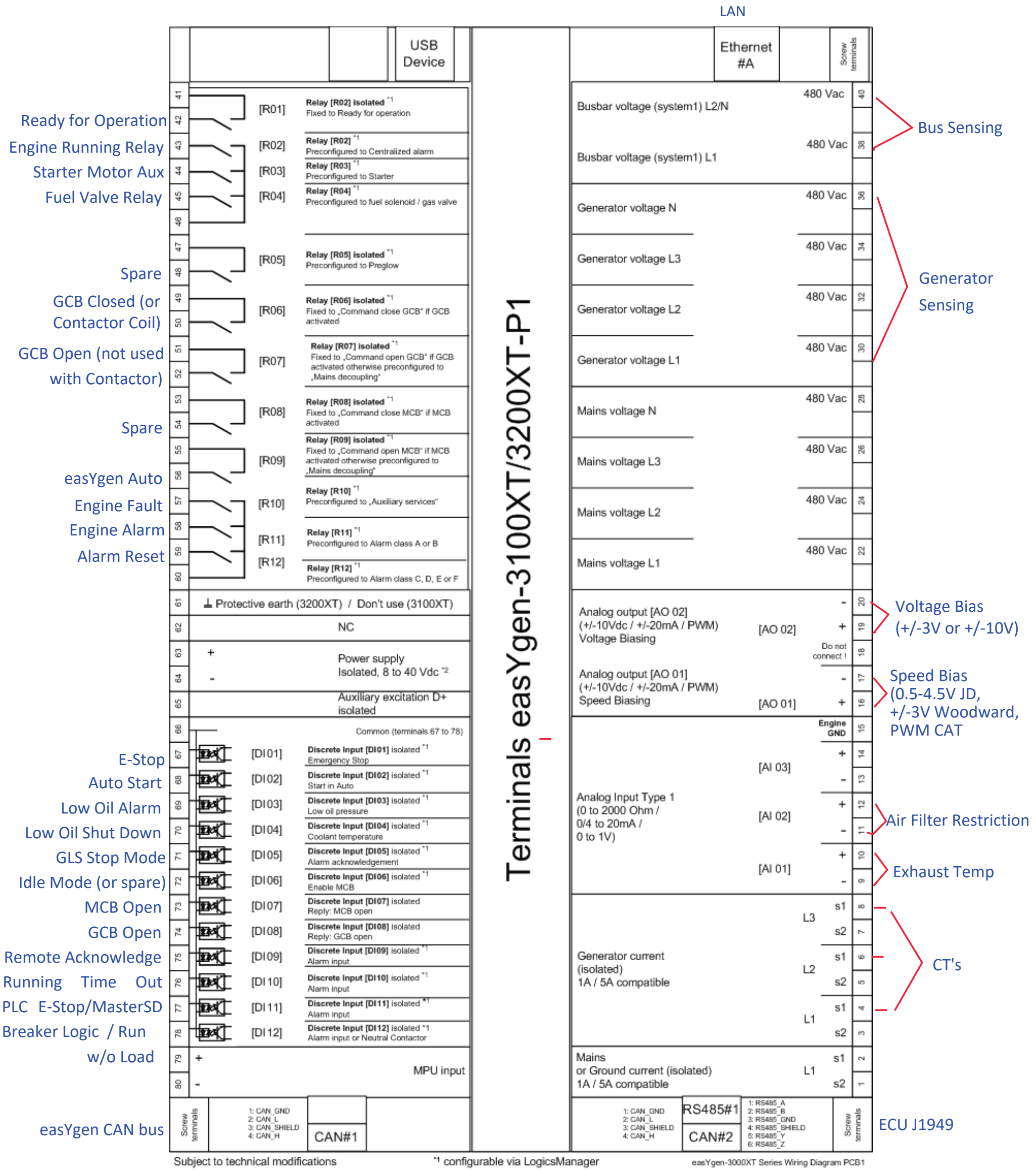

Fig. 21: Wiring diagram easYgen-3100XT-P1/3200XT-P1(-LT)

- 1) Configurable by LogicsManager
- 2) V_{nom} = 12/24 V SELV

Demand Control Table (PLC)				
Demand Control	Generator(s) On Line	On-line kW (Overload)	Level Increase	Level Decrease
Level 1	#3	65	55	---
Level 2	#1 or #2	100	90	45
Level 3	#3 & #1 or #2	165	145	80
Level 4	All	265	---	125

Note : Gen #1 & #2 are equal capacity. Manually select lead unit.

Engine-Generator Alarm Settings (Easygen - EZGN)			
Function	Normal Range	Alarm	Shut Down
Overspeed	1795-1805	----	1900 RPM
Oil Pressure	30-50 PSI	14.5 PSI	10 PSI
Air Filter Vacuum	1-10" H2O	15" H2O	20" H2O
Coolant Temp.	180-200°F	210°F	215°F
Exhaust Temp.	500-850°F	900°F	----
Under Frequency	59.5-60.5 Hz	----	58.2 Hz
Over Frequency	59.5-60.5 Hz	----	61.8 Hz
Under Voltage	470-490 V	----	432 V
Over Voltage	470-490 V	----	528 V
Reverse Power	0	----	10%

Generator Breaker Settings (Easygen - EZGN)	
Function	Setting
Gen #1 Breaker Trip Setpoint (EZGN Rated Current)	200 A
Gen #2 Breaker Trip Setpoint (EZGN Rated Current)	200 A
Gen #3 Breaker Trip Setpoint (EZGN Rated Current)	150 A
Gen Breaker Level 1 (100%) Time Over Current	3 sec.
Gen Breaker Level 2 (120%) Time Over Current	1 sec.
Gen Breaker Level 3 (250%) Time Over Current	0.4 sec.

Feeder Breaker Settings (Feeder Protection Relay - FPR)	
Function (Note: Element 1 is the only active element)	Setting
T.O.C. Trip Pickup (amps) Note: 5A = 100% of CT rating	5.0
T.O.C. Curve Selection	U4
T.O.C. Time Dial	5.00
E.M Reset delay (Y/N)	N
Constant Time Adder (seconds)	0.00
Minimum Response Time (seconds)	0.00
Maximum Phase T.O.C. Torque Control	1

Radiator VFD Settings	
Function	Setting
Min PID Feedback	20
Max PID Feedback	240
rSL (Wake UP Threshold)	1
PID Reference Temperature	175°F
Proportional Gain	0.93
Integral Gain	0.3
Derivative	0
Minimum Speed	10 Hz.
Low Speed Timeout	10 sec.
Loss of Phase	Ignore

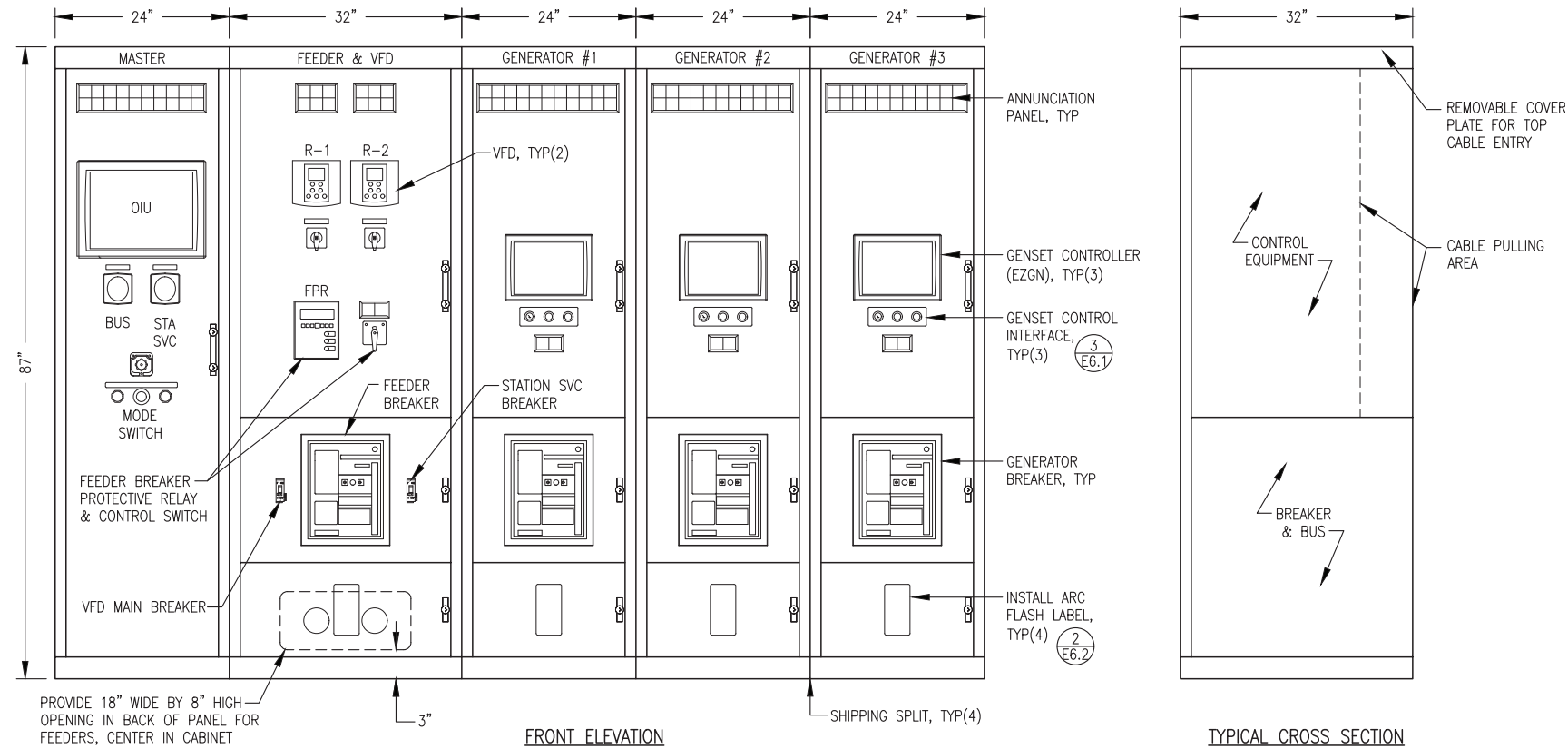

1 SWITCHGEAR ENCLOSURE LAYOUT
E6.1 NO SCALE

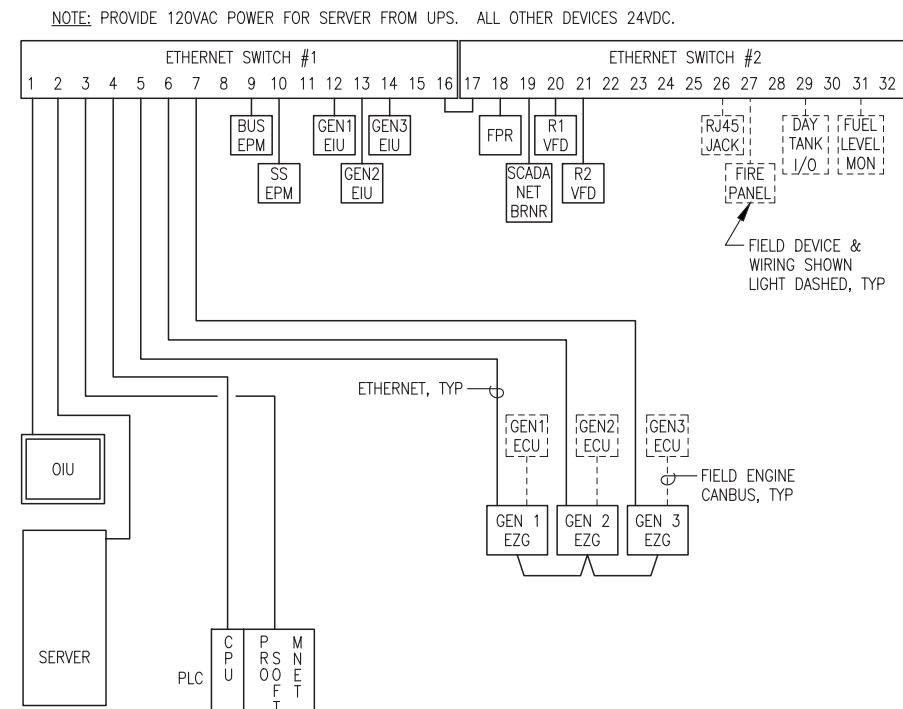

2 COMMUNICATION SCHEMATIC
E6.1 NO SCALE

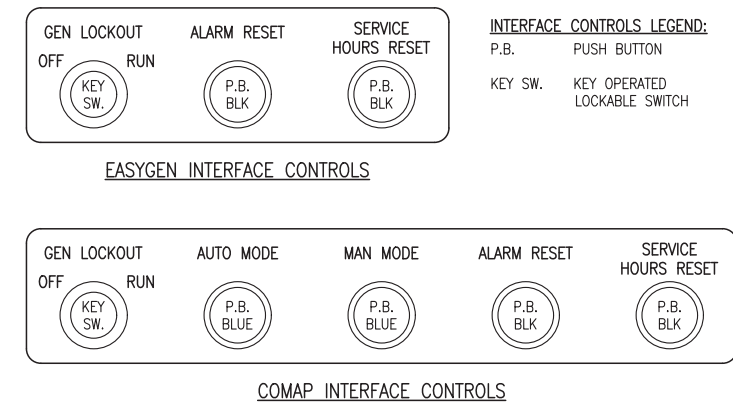

3 GENSET CONTROL (EZGN) INTERFACE CONTROLS
E6.1 NO SCALE

ISSUED FOR SWITCHGEAR PROCUREMENT APRIL 2023



ALASKA ENERGY AUTHORITY		
PROJECT: NELSON LAGOON POWER SYSTEM UPGRADE		
TITLE: SWITCHGEAR ENCLOSURE LAYOUT, SETTING TABLE, & DETAILS		
DRAWN BY: JTD	SCALE: NO SCALE	DESIGNED BY: CWV/BCG
FILE NAME: NELS PP E6	PROJECT NUMBER:	DATE: 4/10/23
P.O. 111405, Anchorage, AK 99511 (907)349-0100		SHEET: E6.1



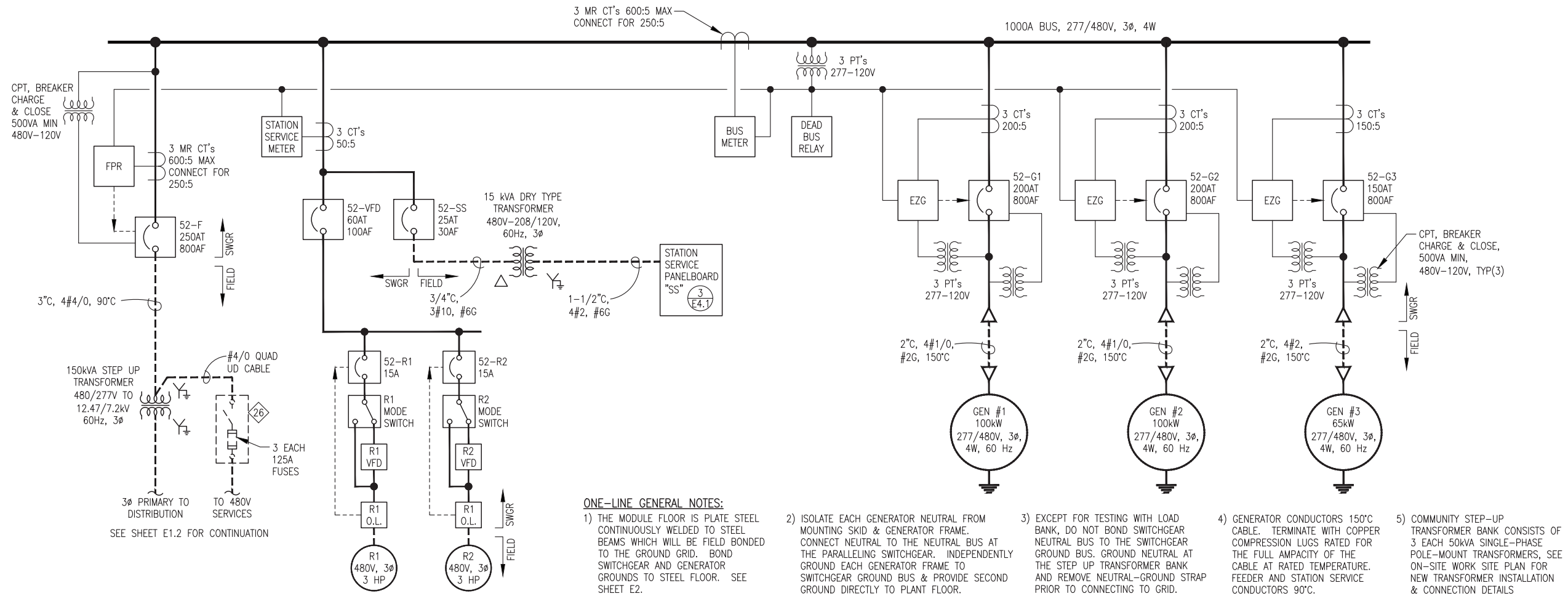

SWITCHGEAR SYMBOL LEGEND	
	TRANSFORMER PT=POTENTIAL XFRMR CPT=CONTROL POWER XFRMR
	CURRENT TRANSFORMER M.R. - INDICATES MULTIRATIO CT'S RATING FACTOR RF=2.0
	CIRCUIT BREAKER AT=AMP TRIP RATING AF=AMP FRAME RATING
	WOODWARD EASYGEN GENSET CONTROLLER
	FEEDER PROTECTION RELAY
	SHOP INSTALLED POWER WIRING/BUS
	FIELD INSTALLED POWER WIRING
	SHOP INSTALLED CONTROL WIRING

ONE-LINE GENERAL NOTES:

- 1) THE MODULE FLOOR IS PLATE STEEL CONTINUOUSLY WELDED TO STEEL BEAMS WHICH WILL BE FIELD BONDED TO THE GROUND GRID. BOND SWITCHGEAR AND GENERATOR GROUNDS TO STEEL FLOOR. SEE SHEET E2.
- 2) ISOLATE EACH GENERATOR NEUTRAL FROM MOUNTING SKID & GENERATOR FRAME. CONNECT NEUTRAL TO THE NEUTRAL BUS AT THE PARALLELING SWITCHGEAR. INDEPENDENTLY GROUND EACH GENERATOR FRAME TO SWITCHGEAR GROUND BUS & PROVIDE SECOND GROUND DIRECTLY TO PLANT FLOOR.
- 3) EXCEPT FOR TESTING WITH LOAD BANK, DO NOT BOND SWITCHGEAR NEUTRAL BUS TO THE SWITCHGEAR GROUND BUS. GROUND NEUTRAL AT THE STEP UP TRANSFORMER BANK AND REMOVE NEUTRAL-GROUND STRAP PRIOR TO CONNECTING TO GRID.
- 4) GENERATOR CONDUCTORS 150°C CABLE. TERMINATE WITH COPPER COMPRESSION LUGS RATED FOR THE FULL AMPACITY OF THE CABLE AT RATED TEMPERATURE. FEEDER AND STATION SERVICE CONDUCTORS 90°C.
- 5) COMMUNITY STEP-UP TRANSFORMER BANK CONSISTS OF 3 EACH 50KVA SINGLE-PHASE POLE-MOUNT TRANSFORMERS, SEE ON-SITE WORK SITE PLAN FOR NEW TRANSFORMER INSTALLATION & CONNECTION DETAILS

1 SWITCHGEAR ONE-LINE DIAGRAM
NO SCALE

ARC FLASH NOTES:

- 1) PERMANENTLY AFFIX ARC FLASH LABELS TO EACH SECTION WITH 480V POWER AS INDICATED.
- 2) SCALED PDF IMAGES OF THESE LABELS WILL BE FURNISHED TO THE FABRICATOR UPON REQUEST.

2 ARC FLASH LABELS
NO SCALE

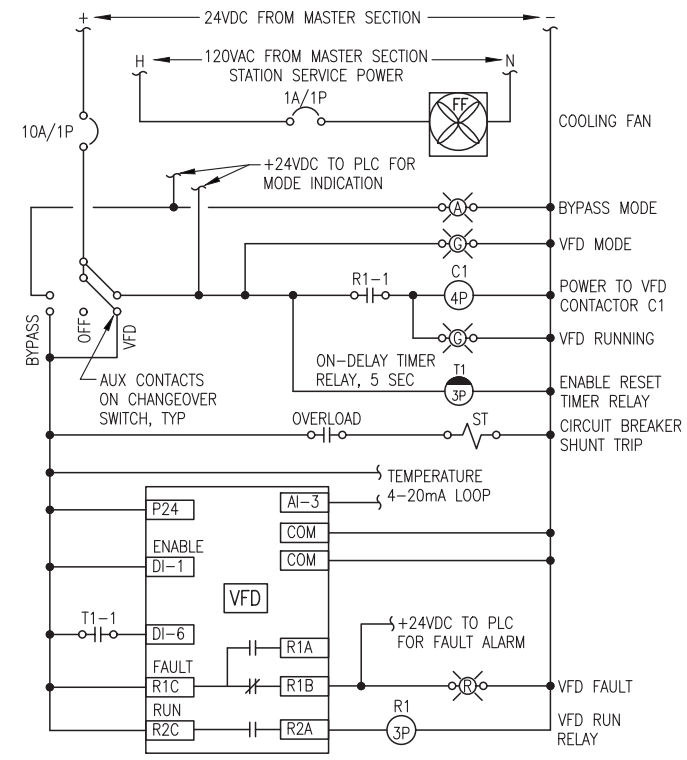

3 TYPICAL RADIATOR VFD LOGIC DIAGRAM
NO SCALE

ISSUED FOR
SWITCHGEAR
PROCUREMENT
APRIL 2023



ALASKA ENERGY AUTHORITY	
PROJECT: NELSON LAGOON POWER SYSTEM UPGRADE	
TITLE: SWITCHGEAR ONE-LINE & SCHEMATICS	
DRAWN BY: JTD	SCALE: NO SCALE
DESIGNED BY: CWV/BCG	DATE: 4/10/23
FILE NAME: NELS PP E6	SHEET:
PROJECT NUMBER:	E6.2



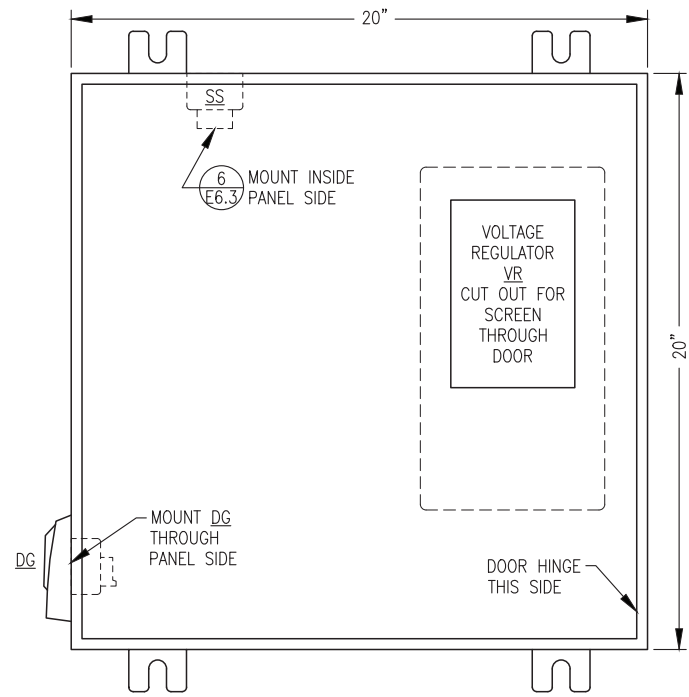

1 JUNCTION BOX FRONT PANEL LAYOUT
E6.3 NO SCALE

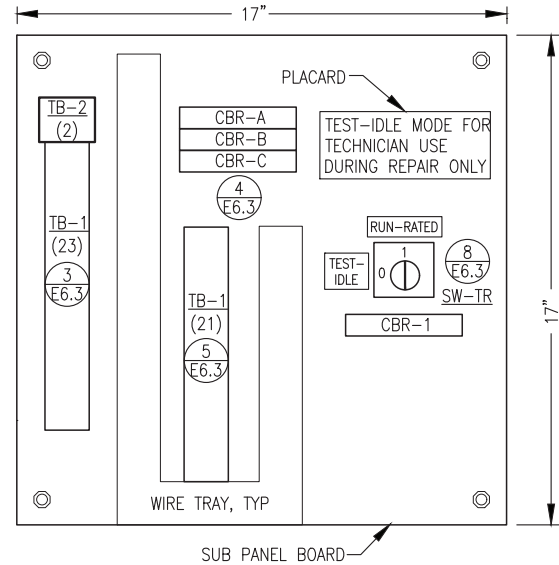

2 JUNCTION BOX SUB PANEL LAYOUT
E6.3 NO SCALE

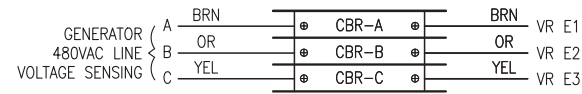

3 TERMINAL STRIP CONNECTIONS
E6.3 NO SCALE

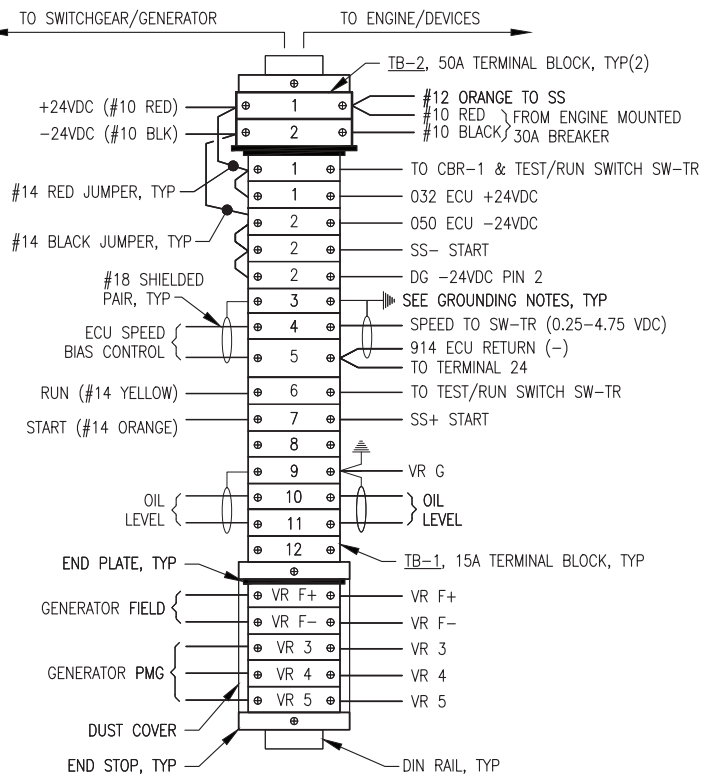

NOTE: TYPICAL JOHN DEERE ECU CONNECTION NUMBERS SHOWN. SEE WIRING HARNESS FOR EACH ENGINE FOR ACTUAL ECU CONNECTIONS.

3 TERMINAL STRIP CONNECTIONS
E6.3 NO SCALE

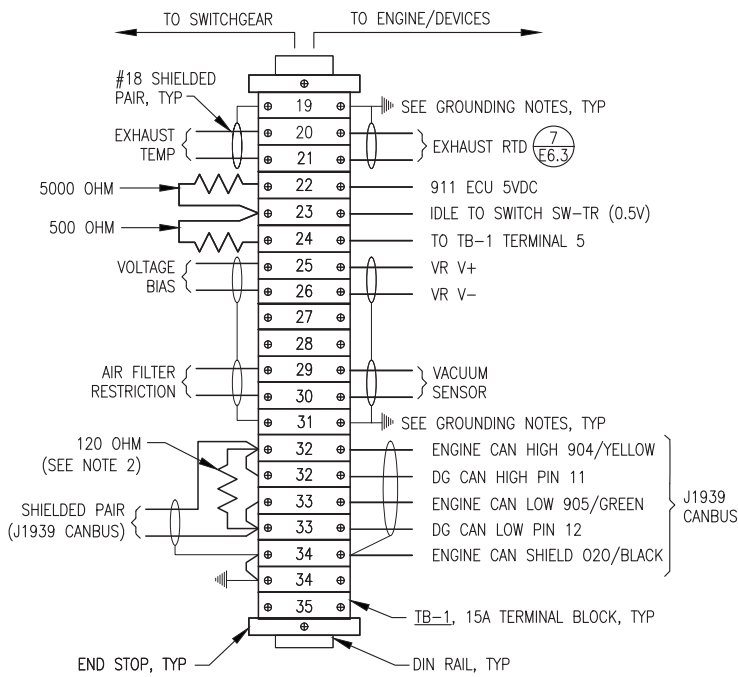

NOTES: 1) ALL RESISTORS 0.25W.
2) REMOVE RESISTOR IF ENGINE WIRING HARNESS HAS 120 OHM END OF LINE RESISTOR.

5 TERMINAL STRIP CONNECTIONS
E6.3 NO SCALE

BILL OF MATERIALS				BRAND SPECIFIC NOTE: SPECIFIC PARTS MANUFACTURER AND MODEL SELECTED NOT ONLY TO MEET PERFORMANCE FUNCTION BUT ALSO TO COORDINATE AND INTERFACE WITH OTHER DEVICES AND SYSTEMS. APPROVED EQUAL SUBSTITUTIONS WILL BE ALLOWED ONLY BY ENGINEER'S APPROVAL. TO OBTAIN APPROVAL, SUBMITTALS MUST CLEARLY DEMONSTRATE HOW SUBSTITUTE ITEM MEETS OR EXCEEDS SPECIFIED ITEM QUALITY AND PERFORMANCE CHARACTERISTICS AND ALSO COMPLIES WITH MECHANICAL AND/OR ELECTRICAL CONNECTIONS AND PHYSICAL LAYOUT REQUIREMENTS.
TAG	MANUFACTURER	MODEL	DESCRIPTION	
CBR-A/B/C	ALLEN-BRADLEY	1489-M1-C010	RAIL MOUNT CIRCUIT BREAKER, 1P, 1A	
CBR-1	ALLEN-BRADLEY	1489-M1-C050	RAIL MOUNT CIRCUIT BREAKER, 1P, 5A	
DG	JOHN DEERE	DG-14	DIAGNOSTIC GAUGE WITH HARNESS PROGRAMMED FOR MARINE TIER 3 WITH UNIQUE JOHN DEERE FAULT CODE	
ENCL.	HOFFMAN	A20H20ALP	20x20x8" NEMA 12 BACK PANEL	
SS	HOFFMAN	A20P20	STARTER AUXILIARY SOLENOID, 24V	
SW-TR	ALLEN-BRADLEY	194L-A12-225-2	CHANGEOVER SWITCH, 12A, 2P	
	ALLEN-BRADLEY	194L-HE-4A-175	90 DEGREE I-O HANDLE	
TB-1	IDEC	BNH15LW	15A DIN RAIL-MOUNT TERMINAL BLOCK	
TB-2	IDEC	BNH50W	50A DIN RAIL-MOUNT TERMINAL BLOCK	
VR	BASLER	DECS-150 5NS1V1N1S	DIGITAL VOLTAGE REGULATOR	

SHOP FABRICATION NOTES:

- PROVIDE ASSEMBLY WITH ALL DEVICES AND WIRING INDICATED.
- INSTALL IN A NEMA 12 ENCLOSURE WITH MOUNTING FLANGES AT BACK, A MIN 14 GAUGE INTERIOR BACK PANEL AND HINGED LOCKABLE DOOR. SIZE AS INDICATED.
- PROVIDE DIN RAIL, TERMINAL END PLATES, TERMINAL END STOPS, TERMINAL DUST COVERS AND OTHER MISCELLANEOUS HARDWARE AS REQUIRED TO MATCH TERMINALS. LABEL ALL TERMINALS EXACTLY AS INDICATED ON THE DETAILS.
- ALL WIRE #14AWG EXCEPT WHERE SPECIFICALLY INDICATED OTHERWISE. LABEL BOTH ENDS OF ALL JUMPERS WITH THE ENGINE PANEL TERMINAL NUMBER.
- PROVIDE MECHANICAL GROUND LUGS FASTENED TO BACK PANEL AND GROUND TO ENGINE-GENERATOR. GROUND ALL SHIELD DRAIN WIRES TO LUGS AT BACK PANEL ONLY.
- PROVIDE WIRING HARNESSES FOR CONNECTION TO GENERATOR AND TO ENGINE. INSTALL WIRES IN LIQUID TIGHT FLEX OR FLEXIBLE PLASTIC WIRE LOOM AND PROVIDE SERVICE LOOPS IN ACCORDANCE WITH SPECIFICATIONS.
- SHOP TEST EACH NEW ENGINE-GENERATOR WITH ASSOCIATED JUNCTION BOX PERMANENTLY CONNECTED. UPON COMPLETION OF TESTING, COIL WIRING HARNESSES AND SECURE JUNCTION BOX TO GENERATOR FOR SHIPPING.

FIELD INSTALLATION NOTES:

- PERFORM ALL FIELD WIRING IN ACCORDANCE WITH SPECIFICATIONS. LABEL BOTH ENDS OF ALL FIELD WIRING WITH THE ENGINE PANEL TERMINAL NUMBER.
- ON SHIELDED CONDUCTORS GROUND ALL SHIELD DRAIN WIRES AT ENGINE J-BOX ONLY. CLIP DRAIN WIRES AT OPPOSITE ENDS.

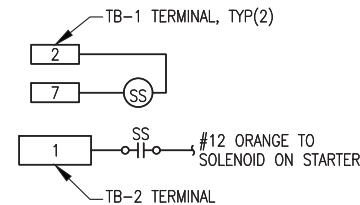

6 STARTER AUX SOLENOID SS WIRING
E6.3 NO SCALE

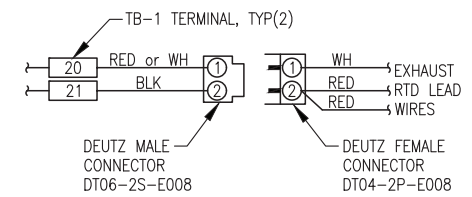

7 EXHAUST RTD CONNECTOR
E6.3 NO SCALE

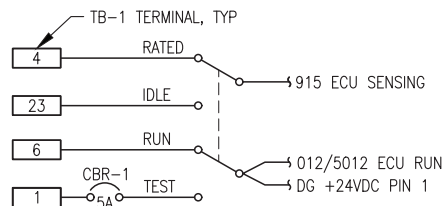

8 TEST-IDLE/RUN-RATED SWITCH SW-TR WIRING
E6.3 NO SCALE

NOTE: THE WIRING JUNCTION BOXES WILL BE FURNISHED WITH THE ENGINE GENERATORS UNDER A SEPARATE CONTRACT AND ARE NOT PART OF THE SWITCHGEAR SCOPE. THIS SHEET IS PROVIDED HERE FOR COORDINATION OF SPECIFIC TERMINALS REQUIRED IN THE SWITCHGEAR GENERATOR SECTIONS FOR INTERCONNECTION

ISSUED FOR SWITCHGEAR PROCUREMENT APRIL 2023



PROJECT: NELSON LAGOON POWER SYSTEM UPGRADE		
TITLE: 24VDC ENGINE WIRING JUNCTION BOX		
DRAWN BY: JTD	SCALE: NO SCALE	
DESIGNED BY: CWV/BCG	DATE: 4/10/23	
FILE NAME: NELS_PP_E6	SHEET: E6.3	
PROJECT NUMBER:		

P.O. 111405, Anchorage, AK 99511 (907)349-0100

SECTION 26 23 05

SCADA SYSTEM FOR PRIME POWER SWITCHGEAR

PART 1 - GENERAL

1.1 SCOPE

- A. The Work consists of providing a complete and operational Supervisory Control and Data Acquisition (SCADA) system, as specified herein. The SCADA system shall be provided by an experienced programmer, referred to as Developer.
- B. The Developer shall develop the SCADA system and programming for the Human Machine Interface (HMI), referred to herein as Operator Interface Unit (OIU), data storage server, and local and remote devices. The SCADA system shall include Supervisory and Trending application software, custom project software file(s), and other software and files required to make a complete and fully functional system.
- C. The Developer shall provide all labor, equipment, incidentals and resources as specified and needed to furnish, install, calibrate, test, start-up and place into service a complete SCADA system, as indicated herein.
- D. The Authority and Utility, herein referred to as Designee(s), shall maintain ownership and use of all custom project software files and documentation developed to meet the requirements of this solicitation. All SCADA Supervisory and Trending application software licenses provided under this solicitation shall include the legal right for the Authority and its Designee(s) to use the software for an indefinite period of time. The Authority and its Designee(s) shall have unlimited rights to install and operate the SCADA Supervisory and Trending application software, up to the number of software licenses issued, and to install, operate and modify the custom project files as needed, without the requirement to commit to on-going maintenance or service agreements.
- E. The Developer shall fully test the SCADA system with the switchgear and generating equipment as specified herein and in Section 26 23 00 - Prime Power Switchgear.

1.2 RELATED REQUIREMENTS

- A. Section 26 23 00 Prime Power Switchgear

1.3 SUBMITTALS

- A. Provide submittals in accordance with Section 26 23 00 Prime Power Switchgear.
- B. Submit data sheets and catalog data showing all supplied features, options and configurations of the SCADA Supervisory and Trending application software.
- C. Submit specific software operating system and version, and quantity of licenses for each of the following: OIU, data storage server, Secure Serial to Ethernet Server, SCADA Supervisory and Trending applications.

- D. Provide a written narrative that describes the purpose and function of each device and the method of communication, i.e., LAN/EtherNet/Modbus TCP/CAN BUS/etc.
- E. Provide a written narrative that describes the methods/protocols available to access the SCADA system both on the local area network (LAN) and remotely via the internet wide area network (WAN), and how many users may simultaneously access the SCADA system (LAN and WAN).
- F. Provide a written description of the SCADA system security encryption and authentication protocol.
- G. Submit screen shots of the proposed OIU screen custom project file(s). Provide a Tag list and narrative operating description of the project file(s).

1.4 SCADA SYSTEM SOFTWARE

- A. All SCADA Supervisory and Trending application software licenses and custom project files, as well as upgrades and maintenance described in the Warranty herein, shall be included in the Developer's bid price.

For the purpose of this solicitation the SCADA Supervisory application software is defined as:

- Machine-readable object code used for the supervision, control and monitoring of the programmable logic controller (PLC) and other switchgear and field devices. The Supervisory application software interacts with custom project file(s) that are configured and customized to display and control tags from the PLC and devices, as indicated in Section 26 23 00 - Prime Power Switchgear.

For the purposes of this solicitation the SCADA Trending application software is defined as:

- Software that provides the functions as described in Paragraph 2.2 - Trending
- B. For the SCADA system to function both the Supervisory application software and custom project files shall be installed on a client device. A client device shall include, but not be limited to, devices that operate on Windows 10, and excludes any Windows-based Server.
- C. The Authority and its Designee(s) shall be able to upgrade the Supervisory and Trending application software and to edit, modify, change, and manipulate the custom project files to fit their requirements.
- D. The Authority shall own outright all other software applications and files developed under this solicitation by the Developer without license and shall have full rights to the files and programming code and may distribute, modify, or install it on any number of computers that may be owned by the Authority or its Designee(s) without additional costs or fees.
- E. For the purposes of this contract "other software applications and files" shall include but may not be limited to:

- Customized screens and parameters developed for use with the Supervisory and Trending application software. (i.e., custom project files).
- Any other software and interfaces developed between the Supervisory and Trending application software, custom project files, and other application software and files related to collecting and reporting power plant data via the SCADA system.

1.5 QUALITY ASSURANCE

- A. The Developer is responsible for quality assurance and completion of all work identified in these specifications. All work shall be subject to evaluation and inspection by the Authority at all times to assure satisfactory progress, and to verify that work is being performed in accordance with the specifications.
- B. The SCADA system shall be furnished by a single Developer who shall assume all responsibility for providing a complete and integrated SCADA system.

1.6 DEVELOPER QUALIFICATIONS

- A. The SCADA system shall be the product of a Developer who can demonstrate at least five (5) years of continuous satisfactory experience in designing, implementing, furnishing and installing comparable SCADA systems for remote installations.
- B. The Developer shall have a thorough working knowledge of remote, off-grid prime power electric power plant controls and operating practices.
- C. A list of five prior projects that key staff have worked on may be requested by the Authority after the bid opening and prior to award in order to verify Developer qualifications. The list shall include installation date, description of installation, and a reference contact for each installation.

1.7 DEVELOPER WARRANTY

- A. The Developer shall warrant the work for a period of not less than one-year. The warranty period shall commence upon acceptance by AEA of field testing with the engine generators and final commissioning of the equipment.
- B. In the event of a failure of the system to perform all specified functions during the warranty period, the Developer shall promptly repair or replace any defective components and revise programming and settings as required to achieve full system function. The Developer shall assist the Authority as directed in determining causes of deficiency or failure.
- C. In addition to the specified requirements for SCADA system programming, testing, commissioning, and warranty work, during the one-year warranty period the Developer shall provide an additional twelve (12) hours of programming assistance and technical support to modify the SCADA as requested by the Authority or its Designee(s). These hours are in addition to any technical requirements specified for programming, start-up, and commissioning efforts, and shall be included in the Developer's bid price. The programming assistance and technical support may be required to be provided at a single event or may be spread out over the year as

directed by the Authority or its Designee(s), and will be performed remotely from the Developer's office and not at the Utility location.

1.8 OPERATION AND MAINTENANCE MANUALS

- A. See Section 26 23 00 - Prime Power Switchgear.

PART 2 - PRODUCTS

2.1 GENERAL

- A. The Developer shall provide a fully functional SCADA system as specified herein and to meet the requirements of Section 26 23 00 - Prime Power Switchgear.
- B. The SCADA system shall be compatible with the switchgear hardware.
- C. The SCADA system shall not require or depend on external hardware for activation, or internet access to function properly.
- D. The Supervisory system shall operate on either the specified Data Storage Server or Secure Serial to Ethernet Server and read information directly from the PLC, switchgear, and power plant devices via the power plant LAN.
- E. The Supervisory system shall not be dependent on connectivity to the internet or any Windows-based server to function properly.
- F. The SCADA system shall be accessible via remote and local devices operating on Microsoft Windows 10 or 11 operating systems.
- G. The Supervisory and Trending software may be separate and distinct programs.
- H. Multiple applications of the SCADA system shall run concurrently. The OIU screens, alarms and monitoring points shall be identical for all SCADA applications, regardless if accessed locally or remotely via the internet. The Developer shall provide a sufficient quantity of SCADA and Trending application software licenses such that all devices in the power plant, and no less than six (6) additional remote (via WAN) or local (via LAN) devices, shall be authorized to access the SCADA system concurrently.
- I. The Supervisory and Trending application software and custom project file(s) shall be relatively small in size and have a simple installation routine. The SCADA system and software installation shall tolerate low throughput and high latency connections, down to as low as 56kbs and 500ms delay without dropping.
- J. The OIU graphic interface shall be user friendly and have the capability without modification or setup to allow personnel with large fingers to use the touch screen without a mouse or keyboard.
- K. The Supervisory system shall start and stop engines, reset alarms, change demand levels and have a confirm action dialog box for critical functions, as well as maintain an alarm log for Type 1 alarms separately from the Master and Type 2&3 alarms (refer to 3.3.H – Alarm History Screens).
- L. The Developer shall maintain a secure FTP or web site with custom project files. Tag lists, installation and operating instructions, and other files necessary to install and operate the SCADA system, readily available to be downloaded and installed.

- M. The Developer shall provide comments in the code that describe the function of each parameter for ease of future maintenance and changes.
- N. The SCADA system installation, setup and modification shall be capable of being performed remotely via low bandwidth internet access.
- O. Provide secure encryption with password protection.

2.2 TRENDING

- A. The Developer shall provide, configure, test and implement a historical database on the switchgear data storage server for historical data archiving, analysis, reporting, trending and system back-up of all data presented by the SCADA system. All historical data shall be fully synchronized and time-stamped, using a single time series (clock), so that historical data from all monitored devices are compared to a single time series. The time and date shall be displayed on the SCADA Status tab.
- B. The SCADA system shall include features for the management of historical data. The SCADA system shall record historical values of analog variables on a periodic basis and values of digital variables on an event basis (change of state). The historical database must be capable of storing a minimum of one (1) year of historical data. All historical data shall be recorded on the switchgear data storage server. Historical files more than one (1) year old shall be automatically deleted.
- C. Trending data from the historical database shall be accessible and exportable both locally and remotely. The section of the trend to be exported shall be selectable by clicking and dragging the mouse across the trend. Any portion of the historical database shall be exportable. Data shall be exported to CSV or TXT formatted files, or similar file system as approved by the Authority. Exported files shall be of a manageable size compatible with the internet requirements of Paragraph 2.1. Exported trend data shall be readily capable of being printed or plotted to Adobe pdf format or to a designated printer.
- D. Refer to Paragraph 3.4, Trending Application Tags, for representative example of historical data to be archived and available for trending.

2.3 SECURITY

- A. Password Protection. Provide at a minimum the following access password protection:
 - 1. Viewing only. In this level of access the viewer will be able to view the SCADA system but will not be able to modify any file or setpoint. Note remote WAN access shall be limited to Viewing only.
 - 2. Local Operator. This level of access is for the local power plant operator. The operator will be able to change the demand levels and timers, change the lead generators, remote start and stop engines, and perform other functions as directed by the Authority. Note local Operator access shall be restricted to LAN access only. The Local Operator password shall be automatically entered each time the OIU/SCADA starts/reboots.
 - 3. Administrator. This level of access is for SCADA Programming, the viewer will be able to control and change all SCADA features and functions.

- B. The Developer shall provide a description of the SCADA system security encryption and authentication protocol for review and approval.

PART 3 - EXECUTION

3.1 SHOP TESTS

- A. Prior to shop testing of the switchgear, the SCADA Supervisory system shall be fully functional as specified in Section 26 23 00 - Prime Power Switchgear.
- B. The switchgear control system shall be fully tested using the SCADA Supervisory system as specified herein.
- C. The OIU shall be fully functional and the switchgear shall be fully tested using the OIU. All alarm, indication, and control functions specified shall be available and indicated on the OIU.
- D. The SCADA Trending application shall be factory tested to the extent practicable.

3.2 CUSTOMER TRAINING

- A. The Developer shall provide a minimum of 8 hours of training for the Authority and Utility personnel.
- B. Training shall occur after substantial completion of the project using the actual power plant equipment. Coordinate with the Authority and Utility to ensure that the appropriate individuals are available.
- C. During training, make modifications to the SCADA system programming as directed by the Authority to incorporate any system control modifications identified during testing, startup, or commissioning.

3.3 OIU SCREEN IMAGES

The SCADA system screens shall display all data as specified in Section 26 23 00 - Prime Power Switchgear. At a minimum, the Developer shall provide screens similar to the images shown in following paragraphs. The screen images are representative of the minimum data required and desired format. Each screen image shall be provided for the following devices: Master Section OIU, local PC's/Devices connected to the LAN, and remote PC's/Devices connected via the internet.

A. Home Screen – Overall Plant Status:

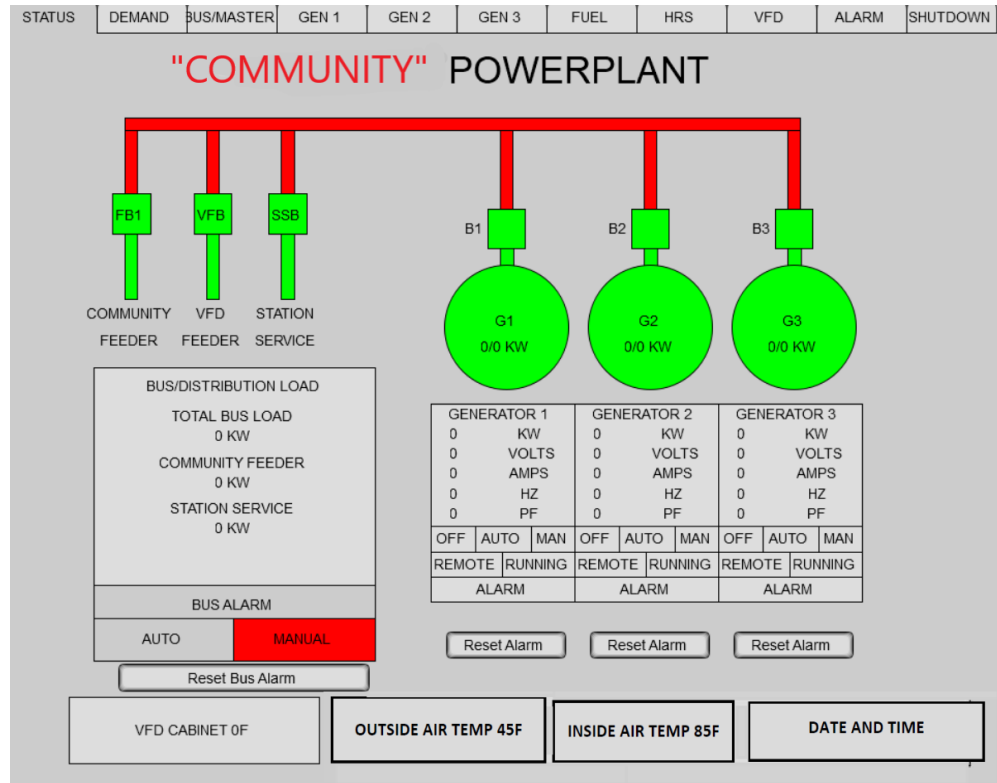

B. Demand Control Screen:

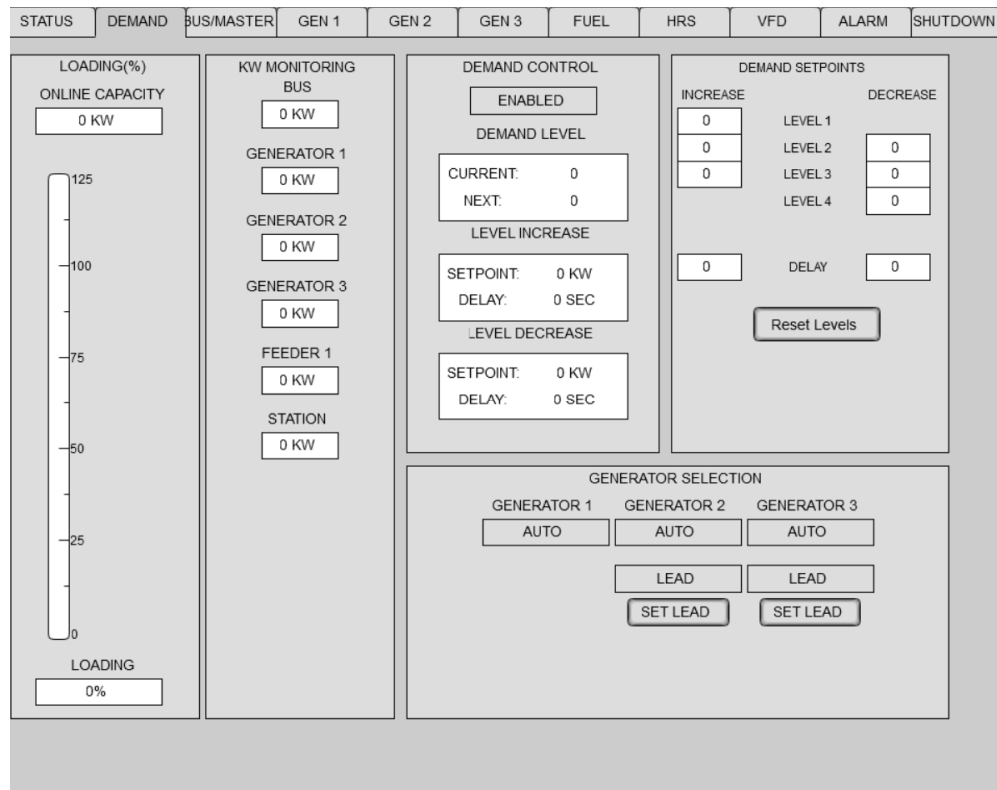

C. Bus Monitoring & Metering Screen:

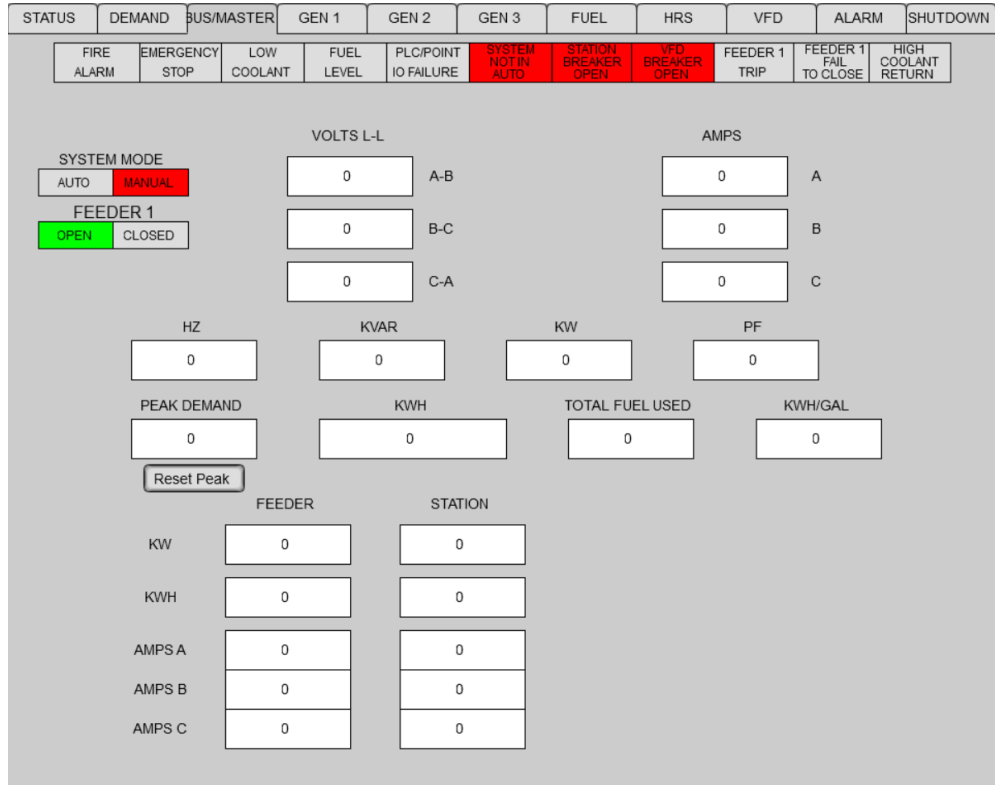

D. Engine-Generator Screen (for engines without charge air cooler):

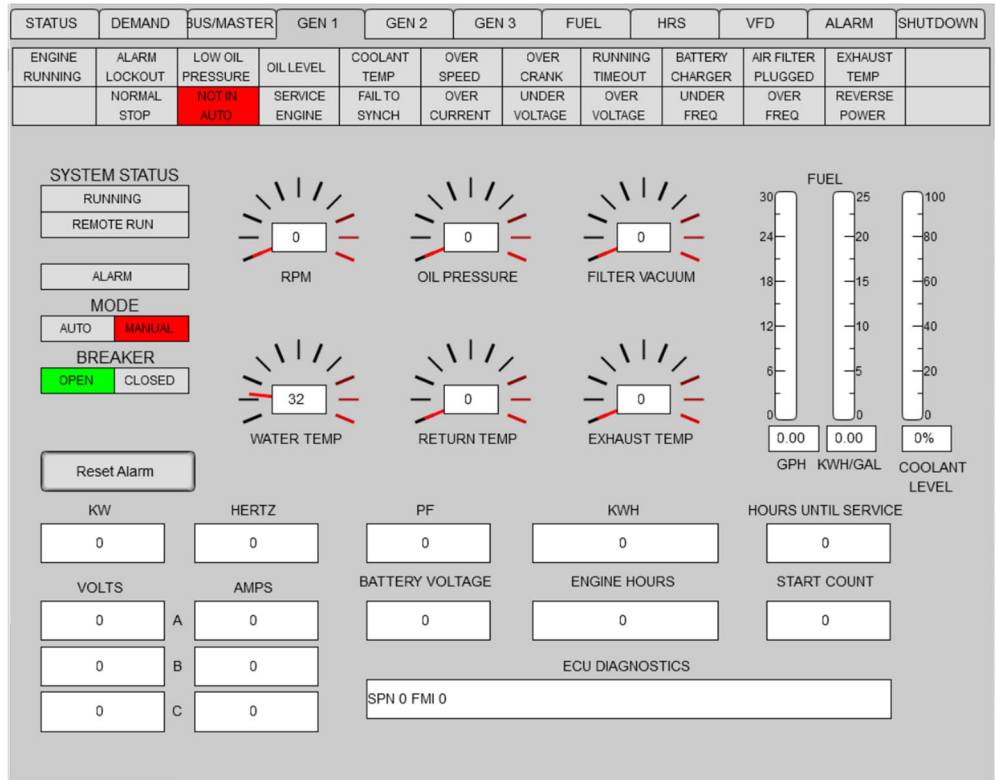

E. Engine-Generator Screen (for engines with charge air cooler):

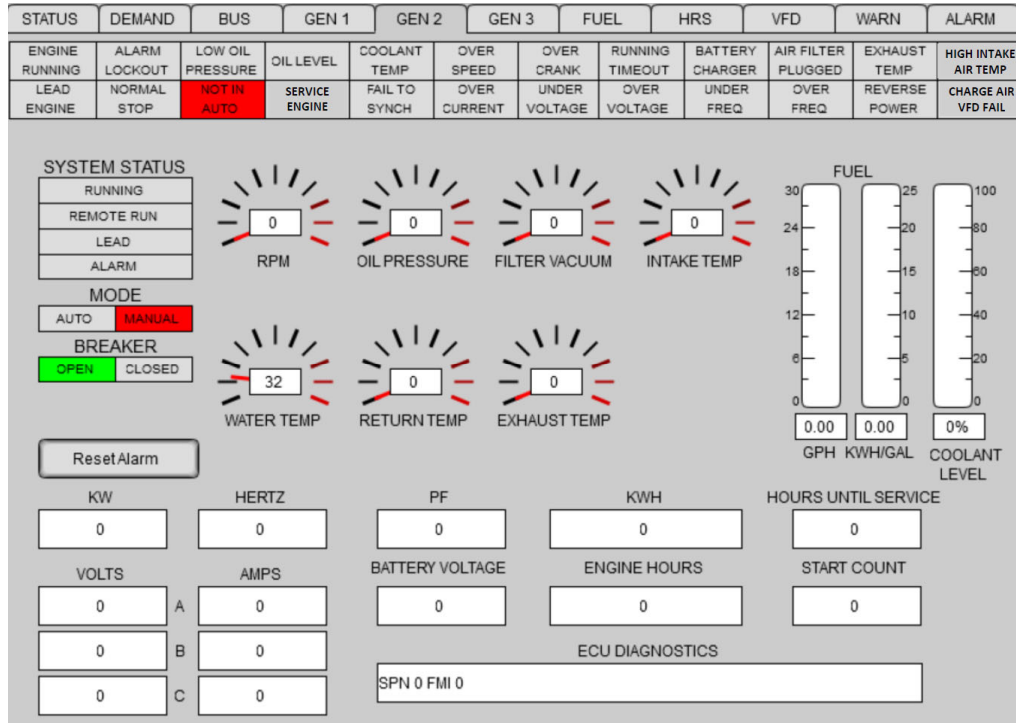

F. Fuel System Monitoring & Alarm Screen:

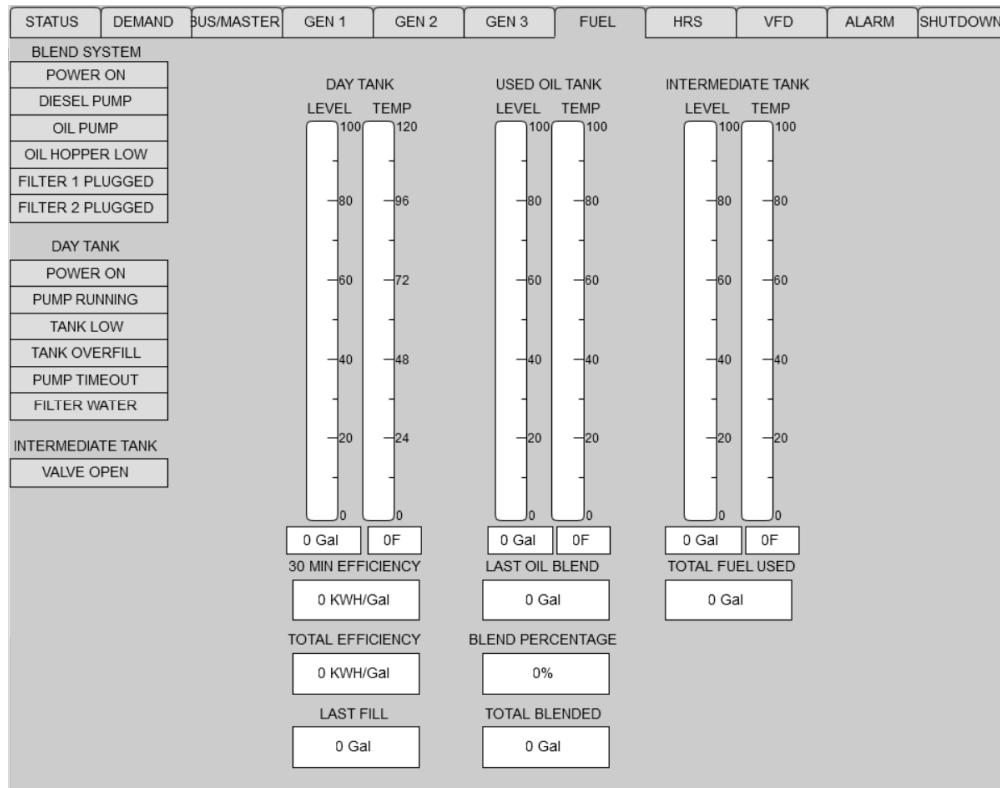

G. Heat Recovery Monitoring & Metering Screen:

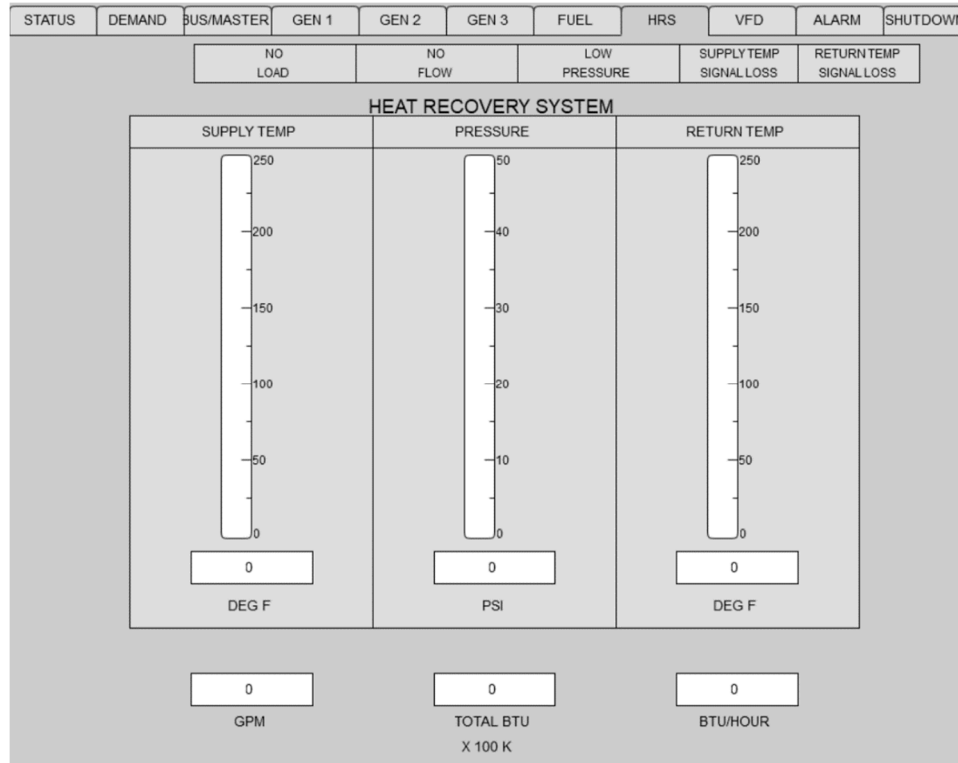

H. Variable Frequency Drive (VFD) Monitoring Screen:

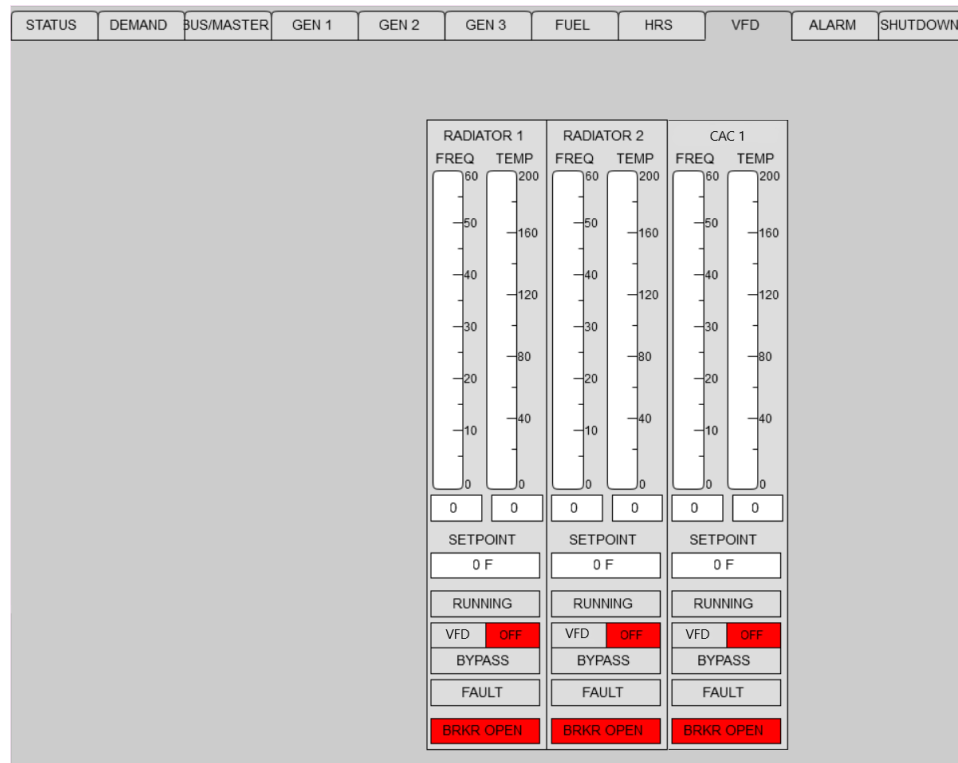

- I. Alarm History Screen: Provide an Alarm History Screen for the following conditions: All Type 1 Engine Soft Shutdown alarms and the Master Section Low Fuel Level, PLC/ Point I/O, System Not In Auto, and Feeder Breaker Trip alarms. The Alarm History screen shall use alternating yellow and white lines.

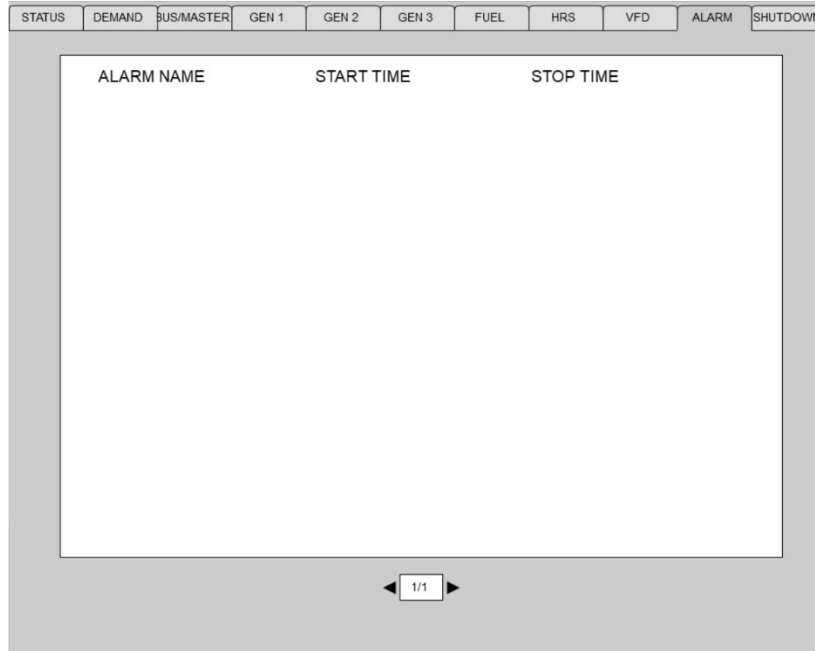

- J. Shut Down History Screen: Provide a Shut Down History Screen for the following conditions: All Type 2 Engine Hard Shutdown alarms, All Type 3 Generation alarms, and the Master Section Fire Alarm, Emergency Stop, and Low Coolant Level alarms. The Shut Down History screen shall use alternating red and white lines.



3.4 TRENDING APPLICATION TAGS

The following Trending Export screens show a representative example of historical data to be archived and available for trending. Provide tags and trend all PLC and SCADA data:

Trending Export ×

Tags

- Boiler/Amps A
- Boiler/Amps B
- Boiler/Amps C
- Boiler/High Water Temperature
- Boiler/KW
- Boiler/KWH
- Boiler/Output Temperature
- Boiler/Output Temperature Signal Loss
- Boiler/Volts A-N
- Boiler/Volts B-C
- Boiler/Volts B-N
- Boiler/Volts C-A
- Bus/Amps A
- Bus/Amps B
- Bus/Amps C
- Bus/Frequency
- Bus/Hertz
- Bus/High Return Temp
- Bus/KVAR
- Bus/KW
- Bus/KWH
- Bus/PF
- Bus/Volts A-B
- Bus/Volts A-N
- Bus/Volts B-C
- Bus/Volts B-N
- Bus/Volts C-A
- Bus/Volts C-N
- Feeder 1/Amps A
- Feeder 1/Amps B
- Feeder 1/Amps C
- Feeder 1/KVAR
- Feeder 1/KW
- Feeder 1/KWH
- Fuel/30 Minute Efficiency
- Fuel/Blend Tank Temperature
- Fuel/Bulk Tank Temperature
- Fuel/Day Tank Temperature
- Fuel/Total Efficiency
- Generator 1/Amps A
- Generator 1/Amps B
- Generator 1/Amps C
- Generator 1/Coolant Temperature
- Generator 1/Coolant Temperature Alarm
- Generator 1/Engine Hours
- Generator 1/Exhaust Temperature
- Generator 1/Exhaust Temperature Alarm
- Generator 1/Fuel GPH
- Generator 1/Fuel Temperature

Start Date

◀ January 2019 ▶

Sun	Mon	Tue	Wed	Thu	Fri	Sat
30	31	1	2	3	4	5
6	7	8	9	10	11	12
13	14	15	16	17	18	19
20	21	22	23	24	25	26
27	28	29	30	31	1	2
3	4	5	6	7	8	9

Today: 1/7/2019

End Date

◀ January 2019 ▶

Sun	Mon	Tue	Wed	Thu	Fri	Sat
30	31	1	2	3	4	5
6	7	8	9	10	11	12
13	14	15	16	17	18	19
20	21	22	23	24	25	26
27	28	29	30	31	1	2
3	4	5	6	7	8	9

Today: 1/7/2019

Interval

15 Minute ▼

Disconnect

Export

Trending Export ☰ ×

Tags

- Generator 1/Fuel GPH
- Generator 1/Fuel Temperature
- Generator 1/Hertz
- Generator 1/KW
- Generator 1/KW Rating
- Generator 1/KWH
- Generator 1/Oil Pressure
- Generator 1/Oil Pressure Alarm
- Generator 1/Oil Temperature Alarm
- Generator 1/RPM
- Generator 1/Volts A-B
- Generator 1/Volts B-C
- Generator 1/Volts C-A
- Generator 2/Amps A
- Generator 2/Amps B
- Generator 2/Amps C
- Generator 2/Coolant Temperature
- Generator 2/Coolant Temperature Alarm
- Generator 2/Engine Hours
- Generator 2/Exhaust Temperature
- Generator 2/Exhaust Temperature Alarm
- Generator 2/Fuel GPH
- Generator 2/Fuel Temperature
- Generator 2/Hertz
- Generator 2/KW
- Generator 2/KW Rating
- Generator 2/KWH
- Generator 2/Oil Pressure
- Generator 2/Oil Pressure Alarm
- Generator 2/Oil Temperature Alarm
- Generator 2/RPM
- Generator 2/Volts A-B
- Generator 2/Volts B-C
- Generator 2/Volts C-A
- Generator 3/Amps A
- Generator 3/Amps B
- Generator 3/Amps C
- Generator 3/Coolant Temperature
- Generator 3/Coolant Temperature Alarm
- Generator 3/Engine Hours
- Generator 3/Exhaust Temperature
- Generator 3/Exhaust Temperature Alarm
- Generator 3/Fuel GPH
- Generator 3/Fuel Temperature
- Generator 3/Hertz
- Generator 3/KW
- Generator 3/KW Rating
- Generator 3/KWH
- Generator 3/Oil Pressure

Start Date

◀
▶
January 2019

Sun	Mon	Tue	Wed	Thu	Fri	Sat
30	31	1	2	3	4	5
6	7	8	9	10	11	12
13	14	15	16	17	18	19
20	21	22	23	24	25	26
27	28	29	30	31	1	2
3	4	5	6	7	8	9

Today: 1/7/2019

End Date

◀
▶
January 2019

Sun	Mon	Tue	Wed	Thu	Fri	Sat
30	31	1	2	3	4	5
6	7	8	9	10	11	12
13	14	15	16	17	18	19
20	21	22	23	24	25	26
27	28	29	30	31	1	2
3	4	5	6	7	8	9

Today: 1/7/2019

Interval

15 Minute
▼

Disconnect

Export

Trending Export ☰ ×

Tags

- Generator 3/Fuel Temperature
- Generator 3/Hertz
- Generator 3/KW
- Generator 3/KW Rating
- Generator 3/KWH
- Generator 3/Oil Pressure
- Generator 3/Oil Pressure Alarm
- Generator 3/Oil Temperature Alarm
- Generator 3/RPM
- Generator 3/Volts A-B
- Generator 3/Volts B-C
- Generator 3/Volts C-A
- HRS/BTU Hour
- HRS/Coolant Return Temp
- HRS/Pressure
- HRS/Return Temp
- HRS/Return Temp Signal Fail
- HRS/Total BTU
- Radiator 1 VFD/Frequency
- Radiator 1 VFD/Temperature
- Radiator 2 VFD/Frequency
- Radiator 2 VFD/Temperature
- Station Service/Amps A
- Station Service/Amps B
- Station Service/Amps C
- Station Service/Frequency
- Station Service/KVAR
- Station Service/KW
- Station Service/KWH
- Station Service/Volts A-B
- Station Service/Volts A-N
- Station Service/Volts B-C
- Station Service/Volts B-N
- Station Service/Volts C-A
- Station/Outside Temp
- Wind 1/Amps A
- Wind 1/Amps B
- Wind 1/Amps C
- Wind 1/Frequency
- Wind 1/KVAR
- Wind 1/KW
- Wind 1/KWH
- Wind 1/Volts A-B
- Wind 1/Volts A-N
- Wind 1/Volts B-C
- Wind 1/Volts B-N
- Wind 1/Volts C-A
- Wind 1/Volts C-N

Start Date

January 2019

Sun	Mon	Tue	Wed	Thu	Fri	Sat
30	31	1	2	3	4	5
6	7	8	9	10	11	12
13	14	15	16	17	18	19
20	21	22	23	24	25	26
27	28	29	30	31	1	2
3	4	5	6	7	8	9

Today: 1/7/2019

End Date

January 2019

Sun	Mon	Tue	Wed	Thu	Fri	Sat
30	31	1	2	3	4	5
6	7	8	9	10	11	12
13	14	15	16	17	18	19
20	21	22	23	24	25	26
27	28	29	30	31	1	2
3	4	5	6	7	8	9

Today: 1/7/2019

Interval

15 Minute

END OF SECTION